

# IQ Battery 5P

## Quick install guide



Scan the QR code for the latest quick install guide



Scanner le code QR pour obtenir le dernier guide d'installation rapide



Escanee el código QR para obtener la última guía de instalación rápida

MODEL  
IQBATTERY-5P-1P-NA

VERSION 10  
MARCH 2025



To install the Enphase IQ Battery 5P and the wall-mount bracket, read and follow all warnings and instructions in this guide. Safety warnings are listed at the end of this guide. These instructions are not meant to be a complete explanation of how to design and install an energy storage system. All installations must comply with national and local codes and standards. Only Enphase-certified installers shall install, troubleshoot, or replace IQ Battery 5P.

The IQ Battery 5P system includes the battery cell pack with integrated IQ Microinverters (SKU: IQ8D-BAT) and the battery management system (BMS). The system requires IQ Combiner 5/5C and IQ System Controller 3/3G for the backup operation. The IQ Gateway measures PV production, IQ Battery 5P charge/discharge power, and home energy consumption, and it senses when it is optimal to charge or discharge the battery so that energy is stored when it is abundant and used when it is scarce. The IQ Battery 5P system provides backup power with Enphase IQ System Controller 3/3G.



# Table of contents

## **What's in the box**

## **Tools/additional items required**

## **Unboxing IQ Battery 5P**

## **Section A Mounting the product**

Plan a location for the IQ Batteries

Step 1: Minimum clearance

Spacing requirements

Step 2: Mounting surface

Step 3: Install the bottom mounting bracket  
and the top shield

## **Section B Installing IQ Battery 5P**

Prepare to install IQ Battery 5P  
on the bottom mounting bracket

Installation of Anchor Clip

## **Section C Wiring**

Install conduit and field wiring

Control (CTRL) wiring between system components

Cable routing and closing the wiring cover

IQ Battery 5P Metering

## **Section D Close and energize the system**

**Disassembly of IQ Battery 5P cover**

**Disengaging Anchor Clip**

**Configure and activate**

## **Operation**

LED overview

Operating mode and set points

Troubleshooting

## **Safety**

## **Revision history**

# What's in the box

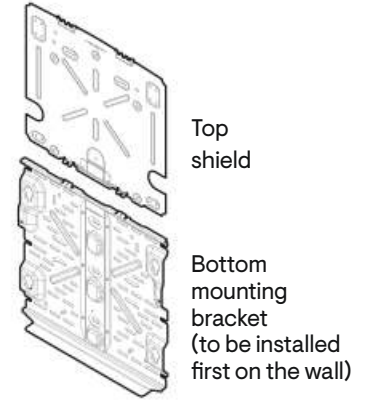
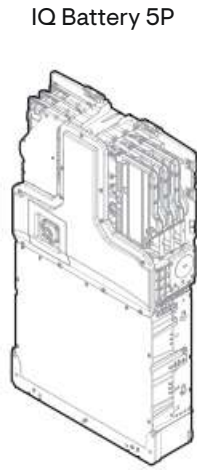
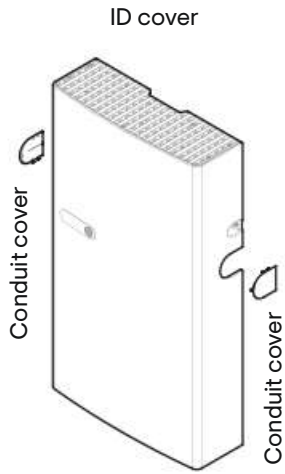

M5 Seismic screw



M4 Grounding screw



M5 ID cover Grounding screw



Anchor Clip

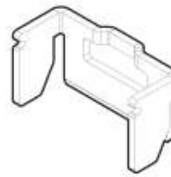

Quick install guide



DESCRIPTION	MODEL NUMBER	QUANTITY
IQ Battery 5P	IQBATTERY-5P-1P-NA	1
ID cover, two conduit covers	B05-CX-0550-O	1
Bottom mounting bracket & top shield	B05-WB-0543-O	1
M5 Seismic screw	—	2
M4 Grounding screw	—	2
M5 ID cover Grounding screw	—	2
Anchor Clip	—	2
Quick install guide	—	1
PCS disclaimer label	—	1
Wall drill template	—	2
Cable tie	—	8
CTRL connector	—	1
CTRL connector with resistor	—	1

# Tools/additional items required

S. NO	ITEM NAME	QUANTITY		SOURCE
1	Conduit (rigid, EMT, PVC, or liquid-tight) up to 32 mm (1-1/4 in) for side entry and up to 19 mm (3/4 in) for rear entry	As required		Provided by the installer
2	Conduit fittings and tools, UL-rated hubs are required for all installations and must be NEMA Type 3R certified when installing outdoors	As required		Provided by the installer
3	Drill	1		Provided by the installer
4	5/32 in pilot bit (or metric equivalent)	1		Provided by the installer
5	Screwdriver	1		Provided by the installer
6	Wrench	1		Provided by the installer
7	Socket wrench	1		Provided by the installer
8	Torque wrench	1		Provided by the installer
9	Level	1		Provided by the installer
10	Conductor stripper	1		Provided by the installer
11	Stud finder (if required)	1		Provided by the installer
12	Copper conductors - No. 10-3 AWG (11 mm or 7/16 in strip length) (rated at 90°C) for terminals	As required		Provided by the installer
13	Control cable (CTRL-SC3-NA-01)	As required		Enphase Store
14	Personal protective equipment for handling lithium batteries as required by local safety standards	As required		Provided by the installer
15	Protective gloves for protection against sharp edges	As required		Provided by the installer
16	#20 (5/16 in) lag bolts or screws to install the bottom mounting bracket. Slots are 9.2 mm (0.36 in) for the wall mount and 11.2 mm (inclined slots) for the pedestal. Check with a structural engineer and local standards for requirements	Single stud mounting (Min. 3)	Dual stud mounting (Min. 4)	Provided by the installer
17	1/4 in screws to fasten the top shield on the wall. Use standard screws only (head thickness <5mm)	Single stud mounting (Min. 6)	Dual stud mounting (Min. 6)	Provided by the installer
18	Washers	As required		Provided by the installer
19	IQ Battery 5P lifting handles. Includes one left-side and one right-side lifting handle (IQBATTERY-HNDL-5)	1		Enphase Store/Provided by the installer

# Tools/additional items required

- ☑ **NOTE:** The Enphase IQ Battery 5P system requires an internet connection through the IQ Gateway in the IQ Combiner. Failure to maintain an internet connection may have an impact on the warranty. See [enphase.com/warranty](https://enphase.com/warranty) for full terms.

The IQ Battery 5P and IQ System Controller are both connected to the IQ Gateway and communicate using communication control cables. The Enphase PV system communicates to the IQ Gateway using powerline communication.

Verify that the main service is either 240 V<sub>L-L</sub>/120 V<sub>L-N</sub> AC or 208 V<sub>L-L</sub>/120 V<sub>L-N</sub> AC. Backup/off-grid is not supported for 208 V<sub>L-L</sub>/120 V<sub>L-N</sub> AC operation.

- ☑ **NOTE:** The rated energy capacity of the battery is 5.0 kWh.

Install the PV system and the IQ Combiner as directed in the Enphase installation manuals.

# Unboxing IQ Battery 5P

Before you unbox IQ Battery 5P, check the “Energize By” label on the shipping box to verify that the IQ Battery(ies) will be installed by the date shown. If the date has passed, contact your distributor to discuss the next steps.

Remove the upper packaging cover and follow the steps as shown in the following image:

**⚠ WARNING:** Do not lift the IQ Battery 5P using microinverters or the plastic behind the microinverters. This may damage the unit permanently.  
Always use handles to lift the IQ Battery 5P.

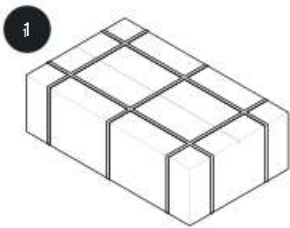

1 Remove the five plastic strips

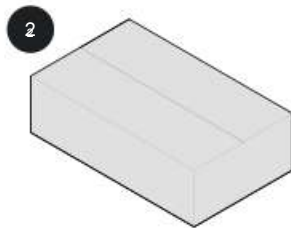

2 Remove the exterior cardboard box lid

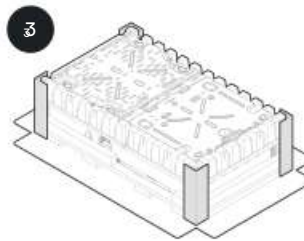

3 Remove the four corner guards

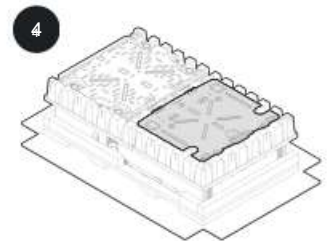

4 Remove the top shield

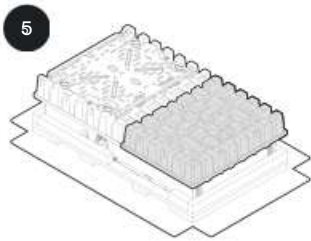

5 Remove the paper tray

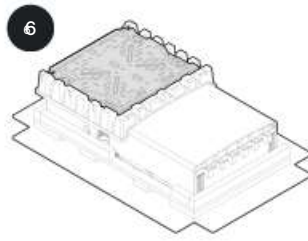

6 Remove the bottom mounting bracket

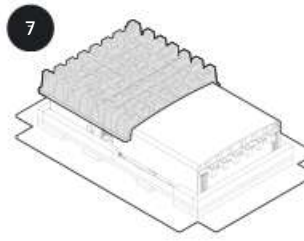

7 Remove the other paper tray to reveal the battery cover

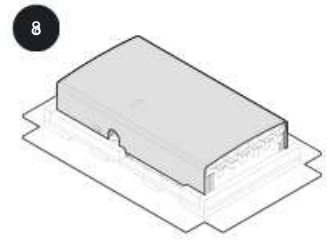

8 Remove the IQ Battery 5P cover

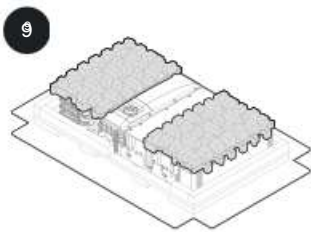

9 Remove the two paper trays

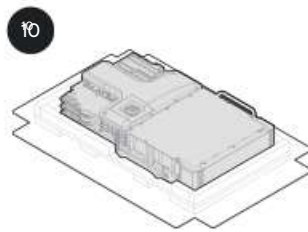

10 Remove the IQ Battery 5P using lifting handles

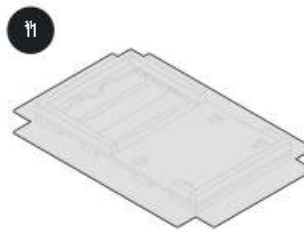

11 Recycle packaging according to local guidelines

Inspect the packaging and the IQ Battery(ies) for any signs of damage, such as cracks, dents, or electrolyte leaks. Do not install or use the IQ Battery(ies) if it has been dropped or damaged in any way. If it is damaged, contact your distributor for replacement.

**⚠ WARNING:** Risk of injury. Take care when lifting. The IQ Battery 5P unit is heavy (66.25 kg/146.05 lb) and requires two people to lift it.

**⚠ WARNING:** Do not lift the packaging with the battery inside after the plastic strips are cut.

## Section A

# Mounting the product

## Choose a location for the IQ Battery array



- The IQ Battery 5P housing is a NEMA Type 3R enclosure. The terminal blocks on the IQ Battery 5P accept a maximum conductor size of 3 AWG for L1/L2 terminals and 8 AWG for the Ground terminal.

**WARNING:** Enphase IQ Batteries have been evaluated by UL solutions to UL 9540A standard for outdoor and non-habitable indoor residential installations. Units are only intended to be installed in attached or detached garages, sheds, and locations more than 152.4 cm (5 ft) from dwelling units, and are not intended for installation in habitable spaces and living spaces in dwelling units.

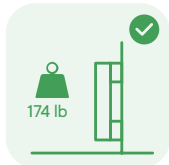

- Ensure the installed location can sustain the total weight of the IQ Batteries and mounting bracket. The total weight for IQ Battery 5P, including the IQ Battery 5P unit, cover, and wall-mount bracket, is 174 lb (78.9 kg). The wall must contain blocked studs that can bear the battery weight or be made of masonry or other suitable structures.
- Ensure there are no pipes or electrical wires where you plan to drill.



- Following local standards, choose a well-ventilated, non-habitable indoor location (like a 2-car garage) or an outdoor location where the ambient temperature and humidity are within -4°F to 131°F (-20°C to 55°C) and 5% to 95% RH, non-condensing. Avoid direct sunlight to ensure the temperature stays in the optimal operating range. This ensures charging and discharging currents are not de-rated due to temperature. The full performance will occur within 59°F to 113°F (15°C to 45°C) while charging and within 41°F to 122°F (5°C to 50°C) while discharging.



- Consider the dimensions of the IQ Batteries, easy access, height, and cable length when selecting the location.
- Select a location where you can interconnect the IQ Battery 5P to the IQ System Controller.



- This product must not be installed at altitudes above 8,200 ft (2,500 m).
- Follow all local standards and regulations set forth by the Authority Having Jurisdiction (AHJ).



- Up to four IQ Battery 5P units can be daisy-chained on a single branch circuit. IQ System Controller 3/3G supports up to a maximum of 80 A breakers for IQ Battery 5P connection circuit.

**NOTE:** Up to eight IQ Battery 5P units can be daisy-chained on a single branch circuit using battery oversubscription PCS. Ensure to add a PCS disclaimer label at all PCS-enabled IQ Battery 5P units, as shown in section D.

- The maximum conductor size for IQ Battery 5P is 3 AWG, and the maximum breaker rating with this conductor size is 80 A.

## Section A - Mounting the product

### Step 1: Minimum clearance

The mounting instructions are for the included wall-mount bracket only. If you wish to install IQ Battery 5P in a floor-mount configuration, order the pedestal accessory (B05-PI-0550-O) and refer to the floor-mount instructions shipped with the product. This product must be installed with clearance at the left, right, top, bottom, and front, as shown in the figure.

Keep IQ Battery 5P away from falling or moving objects, including motor vehicles.

**⚠ WARNING:** If mounted in the path of a motor vehicle, Enphase recommends a minimum mounting height of 91 cm (36 in) above the floor.

For IQ Batteries mounted at the same level, the minimum distance between the covers of two units should be  $\geq 3$  in.

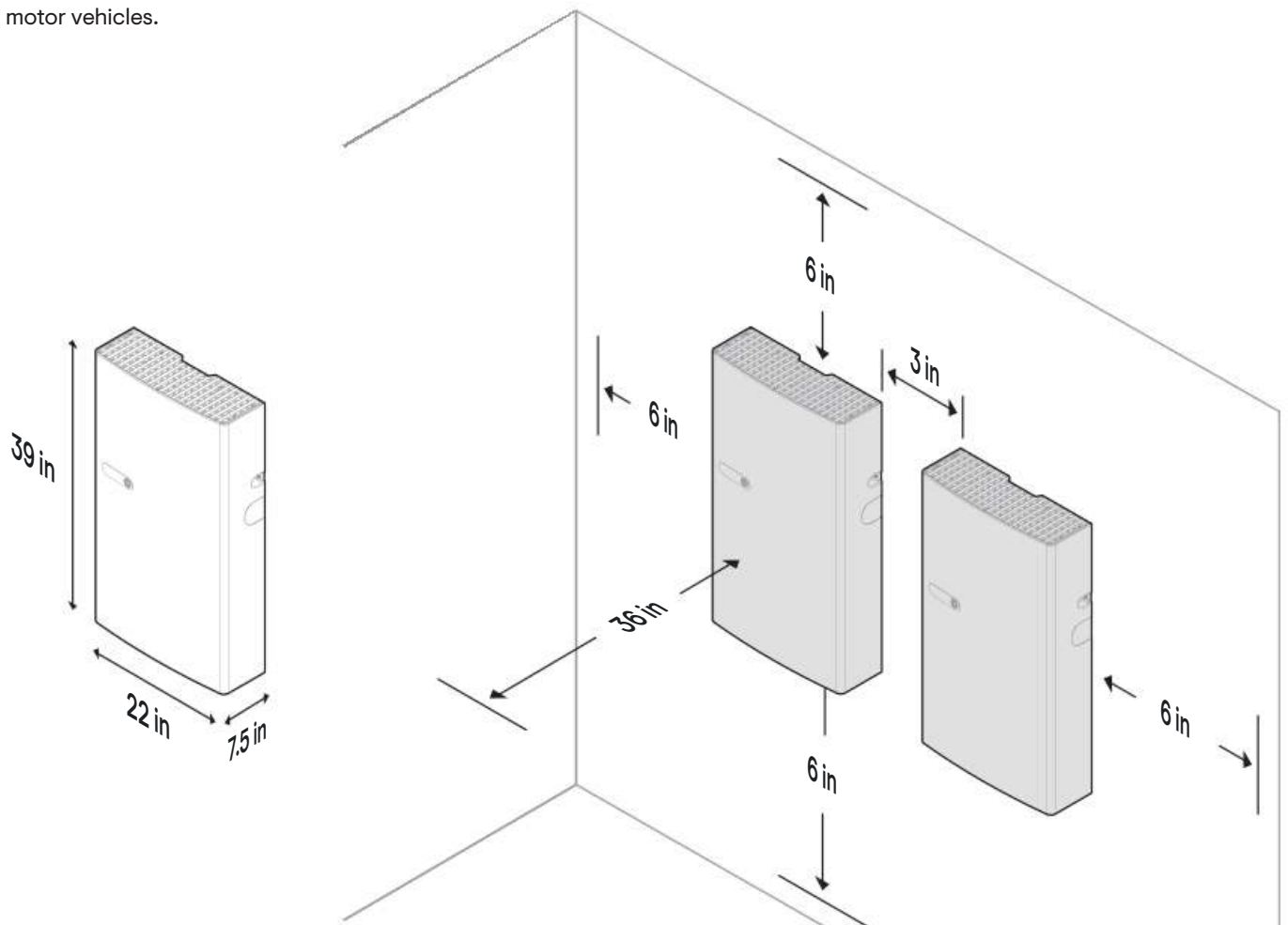

- ✔ **NOTE:** These are minimum manufacturer clearances for indoor and outdoor installation. Ensure to comply with all local compliance and regulation standards.
- ✔ **NOTE:** Installation handles cannot be used for clearance less than 5.5 in. Installers need to consider adjusting the distance between batteries based on the cable bending radius.

## Section A - Mounting the product

### Spacing requirements

Follow the clearances mentioned below to plan the system installation layout.

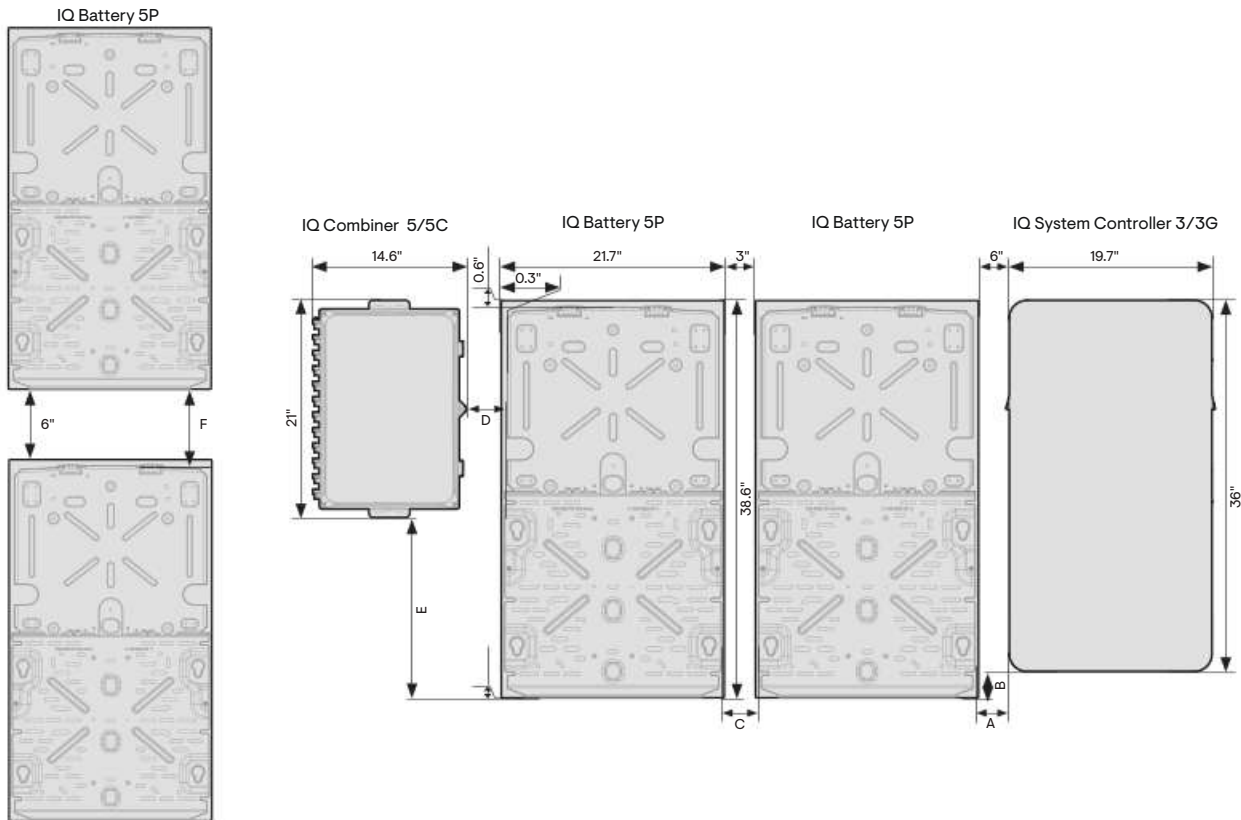

DIMENSION	DESCRIPTION	RECOMMENDED MINIMUM
A	IQ System Controller 3/3G and IQ Battery 5P wall bracket horizontal spacing	6.3 in
B - Bottom aligned	IQ System Controller 3/3G bottom to IQ Battery 5P wall mount bracket bottom	0.00 in
B - Center aligned	IQ System Controller 3/3G bottom to IQ Battery 5P wall mount bracket bottom	1.3 in
B - Top aligned	IQ System Controller 3/3G bottom to IQ Battery 5P wall mount bracket bottom	2.6 in
C	IQ Battery 5P wall bracket horizontal spacing	3.6 in
D	IQ Battery 5P wall bracket to IQ Combiner horizontal spacing	3.6 in
E - Bottom aligned	IQ Combiner 5/5C bottom to IQ Battery 5P wall mount bracket bottom	0.00 in
E - Center aligned	IQ Combiner 5/5C bottom to IQ Battery 5P wall mount bracket bottom	8.7 in
E - Top aligned	IQ Combiner 5/5C bottom to IQ Battery 5P wall mount bracket bottom	17.5 in
F	IQ Battery 5P wall bracket vertical spacing	6.6 in

**NOTE:** IQ Battery 5P must be installed at least 6 inches above the ground. IQ System Controller 3/3G must be installed at least 6 inches above floor for indoor installation and 36 inches above the ground for outdoor installation. IQ Combiner 5/5C must be installed at least 36 inches above ground for installation.

## Section A - Mounting the product

### Step 2: Mounting surface

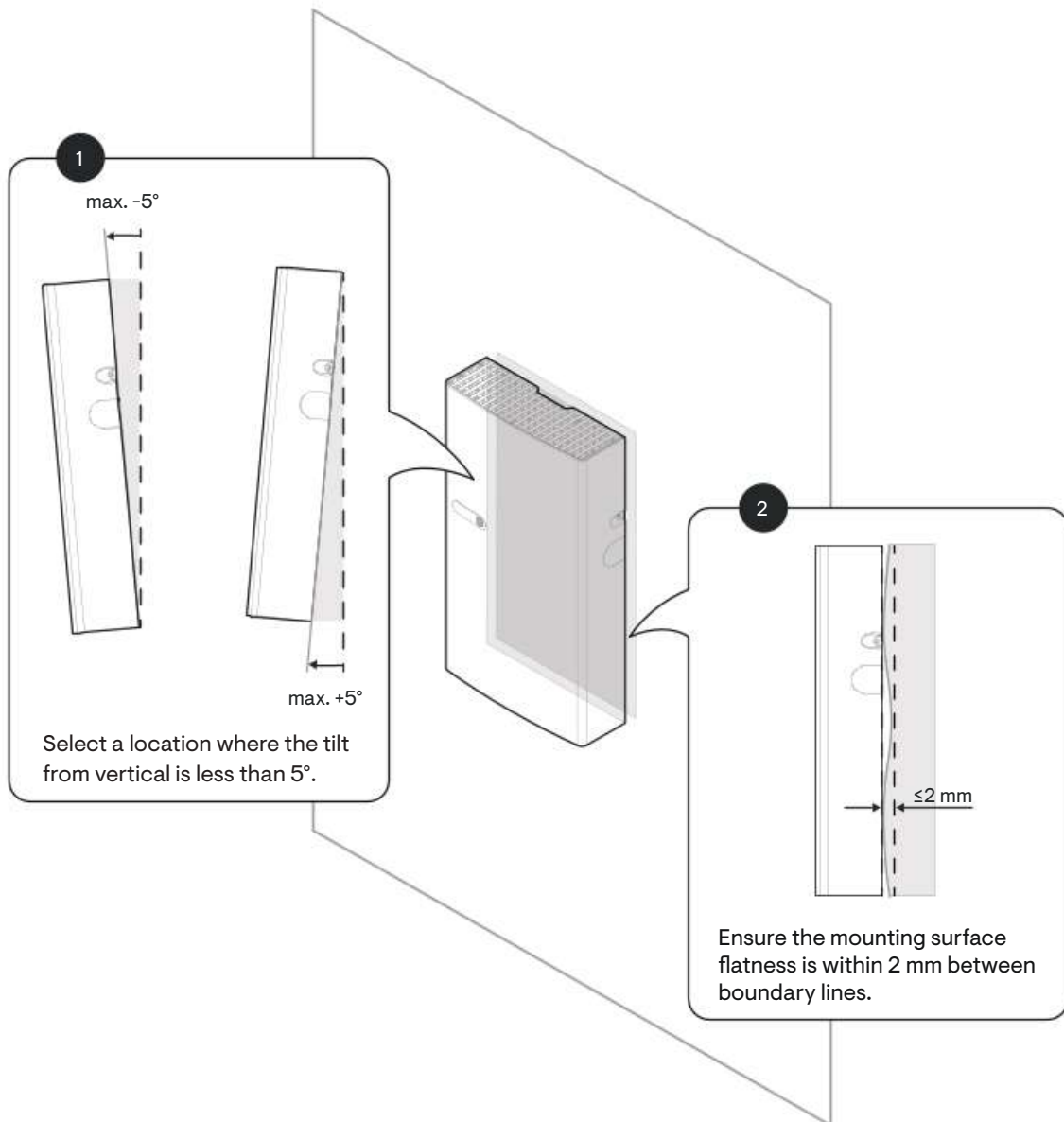

✔ **NOTE:** If the variation of the flatness is more than 2 mm, the battery might not properly sit on the bottom mounting bracket through keyholes. Use spacers if the variation is more than 2 mm.

## Section A - Mounting the product

### Step 3: Install the bottom mounting bracket and the top shield

The bottom mounting bracket carries the weight of the IQ Battery 5P, and the top shield covers the back of the IQ Battery 5P.

**WARNING:** Risk of injury and equipment damage. Do not mount an IQ Battery 5P on a bracket that is not properly mounted.

- Use 1/4 in screws to fasten the top shield to the wall.
- Use #20 (5/16 in) screws/lag bolts (or masonry attachments for masonry wall) to attach the bottom mounting bracket using one screw/lag bolt and washer for each slot (9.2 mm/0.36 in).

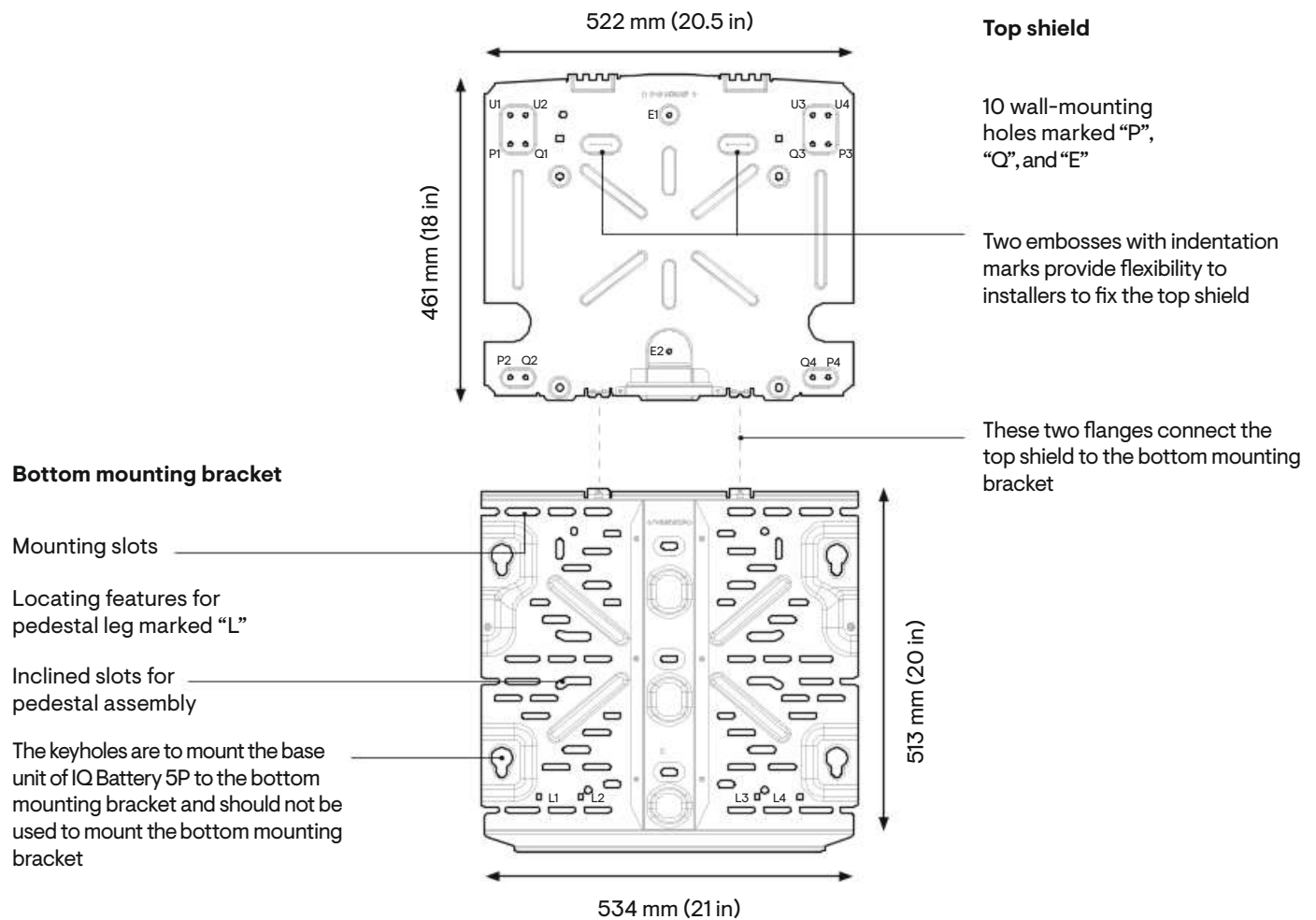

## Section A - Mounting the product

Install the bottom mounting bracket as per the following instructions.  
Ensure the bottom mounting bracket is solidly attached to the wall.

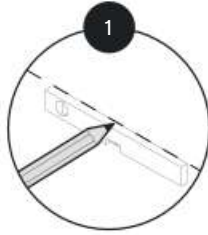

Starting at the installation position closest to the power source, mark a level line on the wall as a guide.

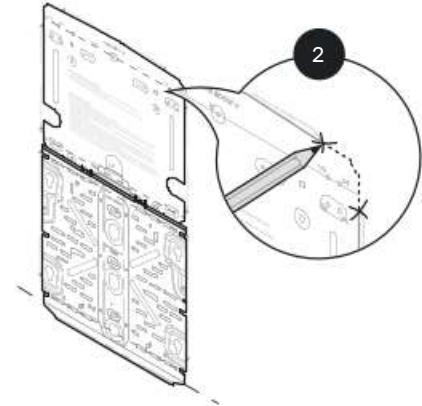

For the ease of marking all the required drilling points, a dedicated drill template is provided along with the packaging. Depending on the type of installation wall, choose the instructions stated on the template.

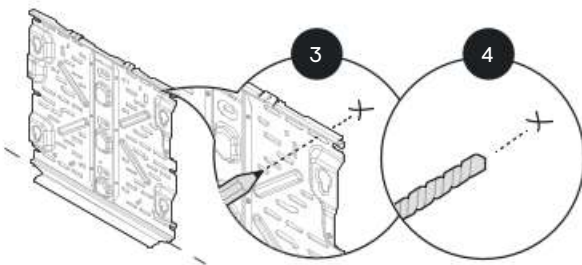

 **WARNING:** Multiple risks. Ensure not to drill into or attach to electric wiring or pipes in the wall.

# Section A - Mounting the product

## Mounting on multiple vertical studs (450 mm/17.72 in stud spacing)

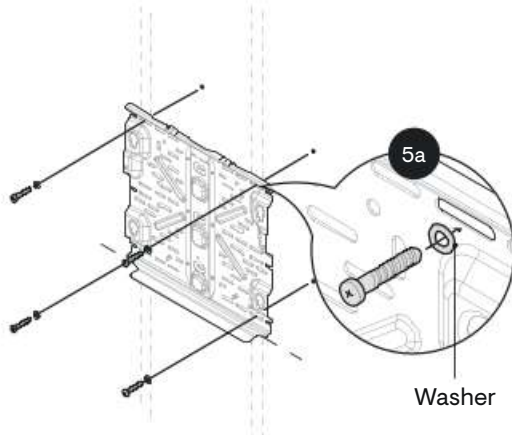

Position the bottom mounting bracket on the wall and fasten it using the mounting slots. Use a minimum of four screws/lag bolts (symmetrically distributed) for dual stud mounting. Tighten all screws to the manufacturer's specified torque values.

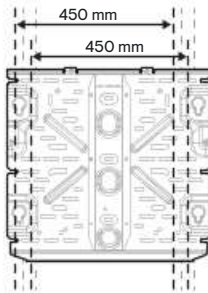

The bottom mounting bracket can accommodate a slight offset in stud positioning with respect to the battery unit with pre-drilled holes/slots, as shown in the image.

## Mounting on a single vertical stud

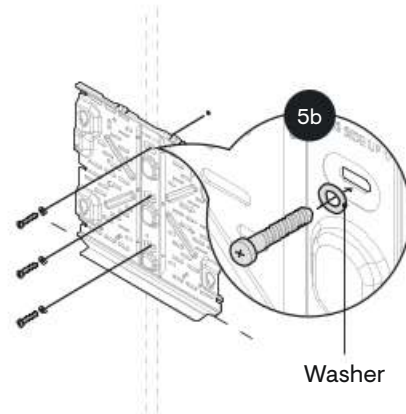

Position the bottom mounting bracket on the wall and fasten it using the mounting slots. Use a minimum of three screws/lag bolts (on the centerline) for single-stud mounting. Tighten all screws to the manufacturer's specified torque values.

✔ **NOTE:** Any one of the above mounting methods can be used for mounting a battery on a masonry wall.

## Section A - Mounting the product

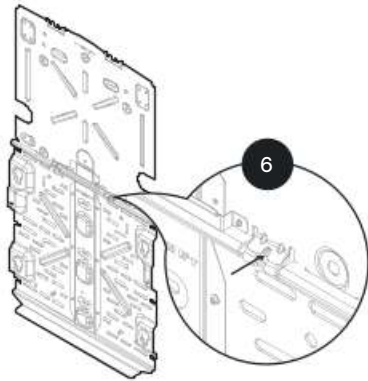

Position the ground contact flange of the top shield on that of the bottom mounting bracket and align the screw slot/hole.

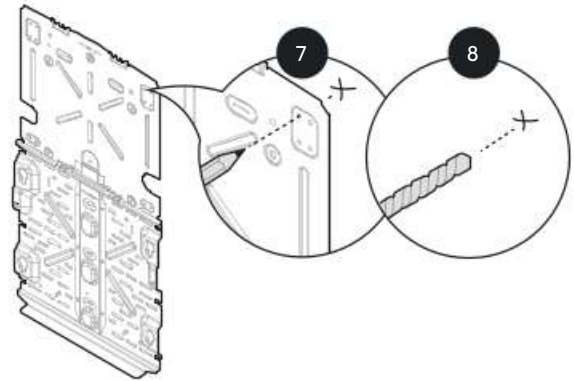

**⚠ WARNING:** Multiple risks. Ensure not to drill into or attach to electric wiring or pipes in the wall.

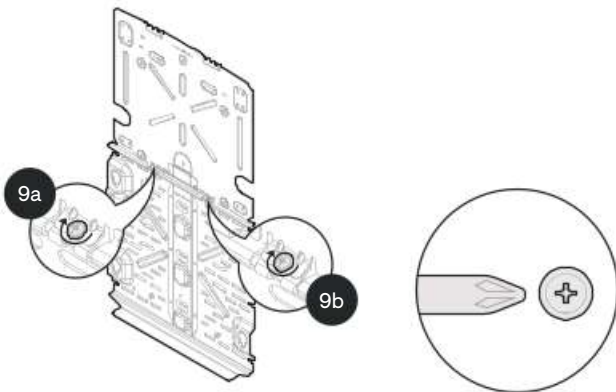

Partially tighten the top shield to the bottom mounting bracket at the ground contact flange.

Two M4 grounding screws

**✓ NOTE:** The top shield is not a structural part and does not always need to be mounted to the studs. It can be fastened to the supporting wall with the pre-drilled holes if the studs are not aligned.

## Section A - Mounting the product

### Mounting on multiple vertical studs

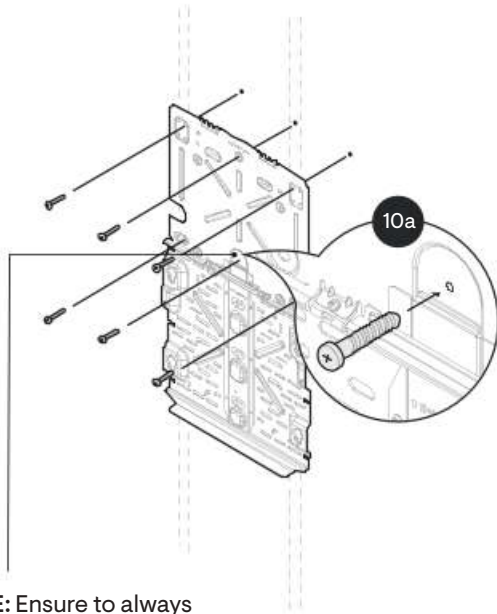

✔ **NOTE:** Ensure to always fasten this screw.

### Mounting on single vertical stud

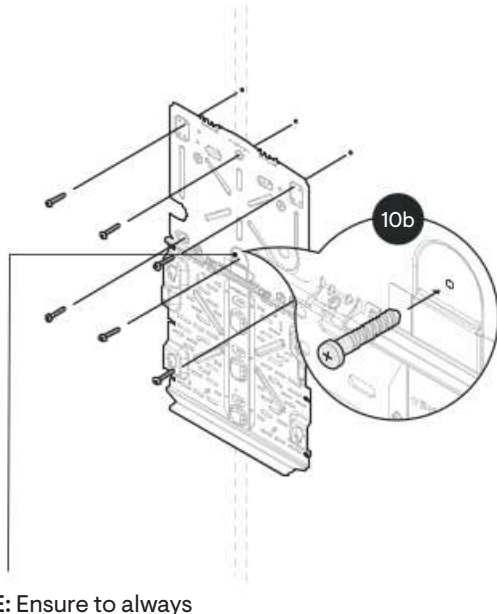

✔ **NOTE:** Ensure to always fasten this screw.

Fasten the top shield using the mounting holes. Use a minimum of six screws for single stud and dual stud mounting to fasten the top shield to the wall. Use standard screws only (head thickness <5 mm). Finally, fully tighten the grounding screws (torque to 1.5 N m/ 13.28 lb-in).

✔ **NOTE:** Use an electric drive; do not use impact drives/impact drills while tightening grounding screws.

## Section B

# Installing IQ Battery 5P

## Prepare to install IQ Battery 5P on the bottom mounting bracket

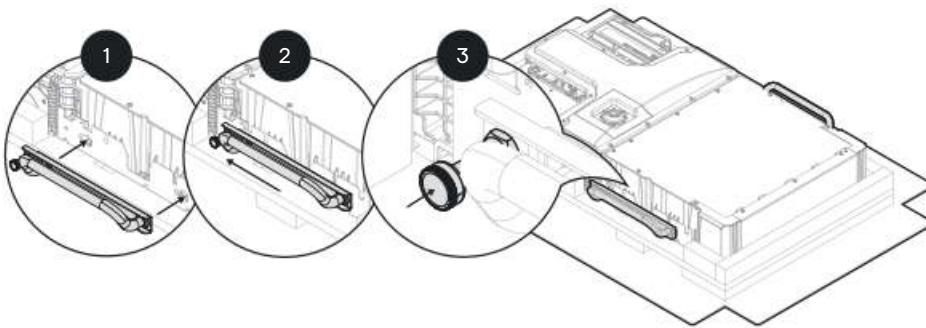

✔ **NOTE:** Ensure to complete all steps before installing IQ Battery 5P on the wall.

Remove the ID cover from the packaging and keep it aside. Use the reusable lifting handles (sold separately). Check that the plungers are extended and ready to engage into the IQ Battery 5P slots.

Align the left handle on the left side of IQ Battery 5P, insert it into the slots, and slide it toward the top of the IQ Battery 5P enclosure until it locks into place. Check that the handle is secure.

Repeat this procedure on the other side with the right handle.

⚠ **WARNING:** Risk of injury and equipment damage. The total lifting weight with handles attached is 148.5 lb. Lift according to local law. Handles must be used while lifting the battery. Two-person manual lifting is allowed only if permitted by local law; otherwise, use mechanical lifting.

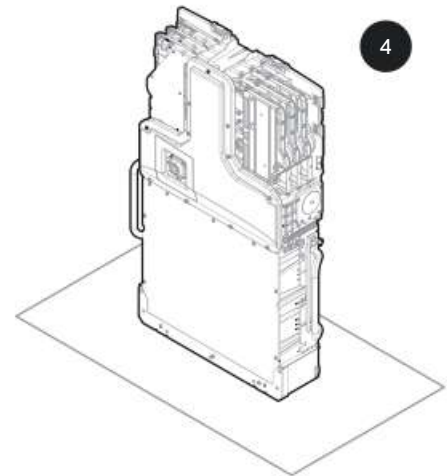

Two people together must lift the IQ Battery 5P unit from the packaging using the handles and place it in an upright position on a flat surface.

⚠ **WARNING:** Lift IQ Battery 5P from the packaging using the handles and ensure the battery's front side is facing toward you.

⚠ **WARNING:** Do not lift the IQ Battery 5P using microinverters or the plastic behind the microinverters. This may damage the unit permanently.

## Section B - Installing IQ Battery 5P

- 5 IQ Battery 5P can have the field cable entry from the back, left, or right side. Finalize the side from where the field cable enters and leaves IQ Battery 5P. Use the following table to decide the cutout for all the units.

**NOTE:** The conduit may be rigid, EMT, PVC, or liquid-tight. The rear entry can support the conduit with a diameter of 1/2 in (13 mm) to 3/4 in (19 mm), while the side entry can support the conduit with a diameter of 1/2 in (13 mm) to 1-1/4 in (32 mm). Follow manufacturer-recommended instructions for conduit installation.

**⚠ DANGER:** Risk of electric shock. The DC control switch must be in the OFF position before performing this step.

NAME	BACK VIEW	LEFT-BACK CONDUIT	RIGHT-BACK CONDUIT	LEFT-SIDE CONDUIT	RIGHT-SIDE CONDUIT
Both side conduit		✗	✗	✓	✓
Only left side conduit*		✗	✗	✓	✗
Only right side conduit*		✗	✗	✗	✓
Left-side conduit and right-back conduit		✗	✓	✓	✗
Left-back conduit and right-side conduit		✓	✗	✗	✓
Both back conduit		✓	✓	✗	✗
Only left back conduit*		✓	✗	✗	✗
Only right back conduit*		✗	✓	✗	✗

\* One-side conduit configuration is supported only if the system has one IQ Battery 5P or for the unit last in the daisy chain farthest from the IQ System Controller.

## Section B - Installing IQ Battery 5P

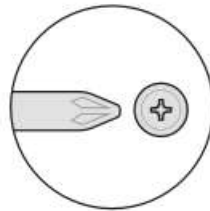
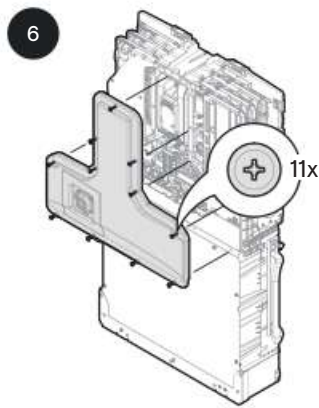

Refer to the red caution label on the unit for the torque value

Open the front wiring cover by unfastening the 11 captive screws from the wiring cover. Use an electric drive; do not use impact drives/impact drills.

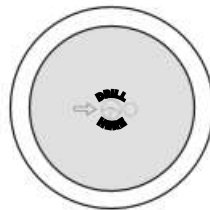
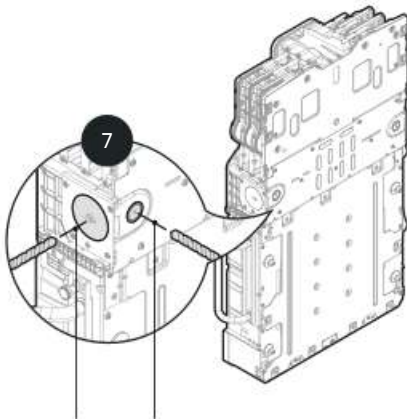

Drill here

Drill to appropriate cutout

Drill the appropriate cutout on either the back or side of the unit or on both based on configurations. The rear entry can support the conduit with a diameter of 1/2 in (13 mm) to 3/4 in (19 mm) while the side entry can support the conduit with a diameter of 1/2 in (13 mm) to 1-1/4 in (32 mm). Decide the required conductor size for L1, L2, GND, and cutout diameter based on the conduit selected.

**⚠ WARNING:** Ensure that the drilling machine does not touch any internal components or walls.

**⚠ WARNING:** Clean the debris from inside the battery unit after drilling.

**✔ NOTE:** Before mounting the unit on the wall, drill the appropriate cutout. Drilling after mounting the unit to the wall can lead to internal component damage, which is not covered by the warranty.

## Section B - Installing IQ Battery 5P

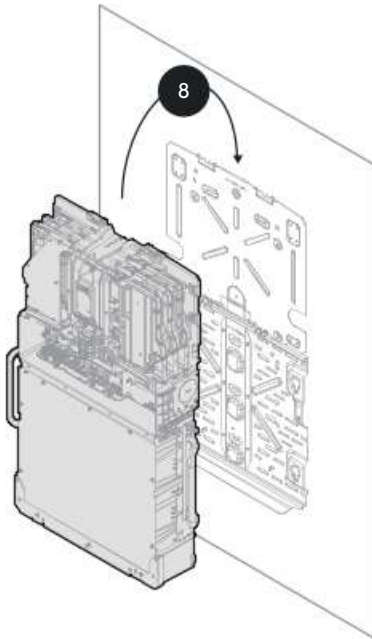

Bring the IQ Battery 5P unit to the already mounted bottom mounting bracket.

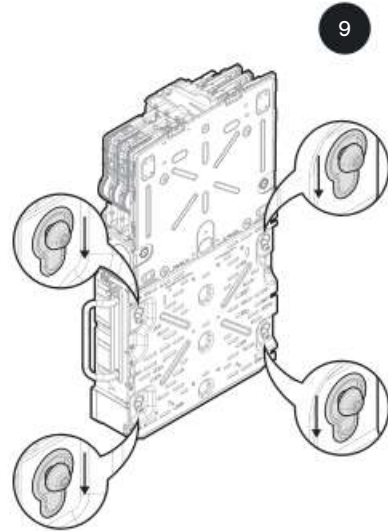

Hold IQ Battery 5P straight, align, and insert four mount bolts on the battery unit into the bottom mounting bracket keyholes and slide it down.

✔ **NOTE:** Use lift assist to avoid any mishap during lifting.

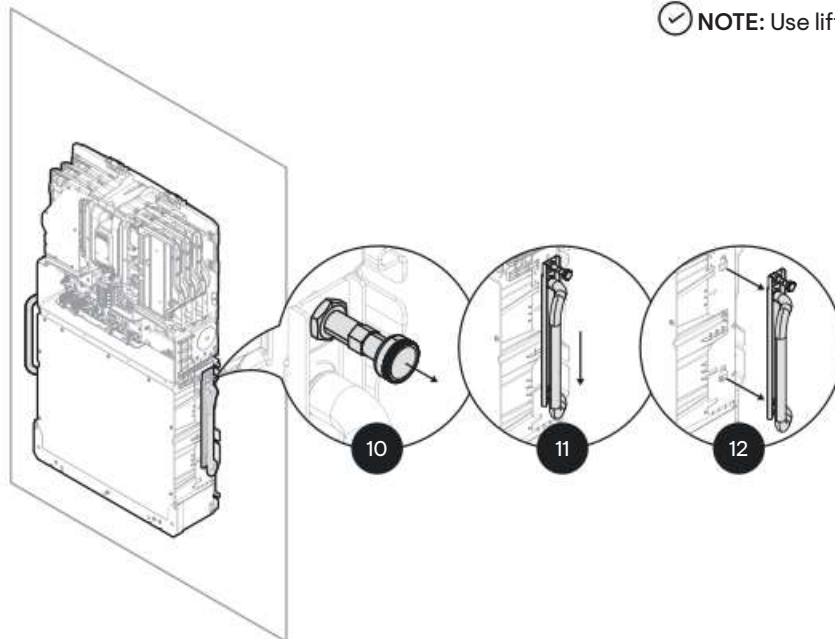

To remove the installation handles, pull the plunger outward to unlock them. Then, slide the handle down and pull it away from the unit to remove it.

## Section B - Installing IQ Battery 5P

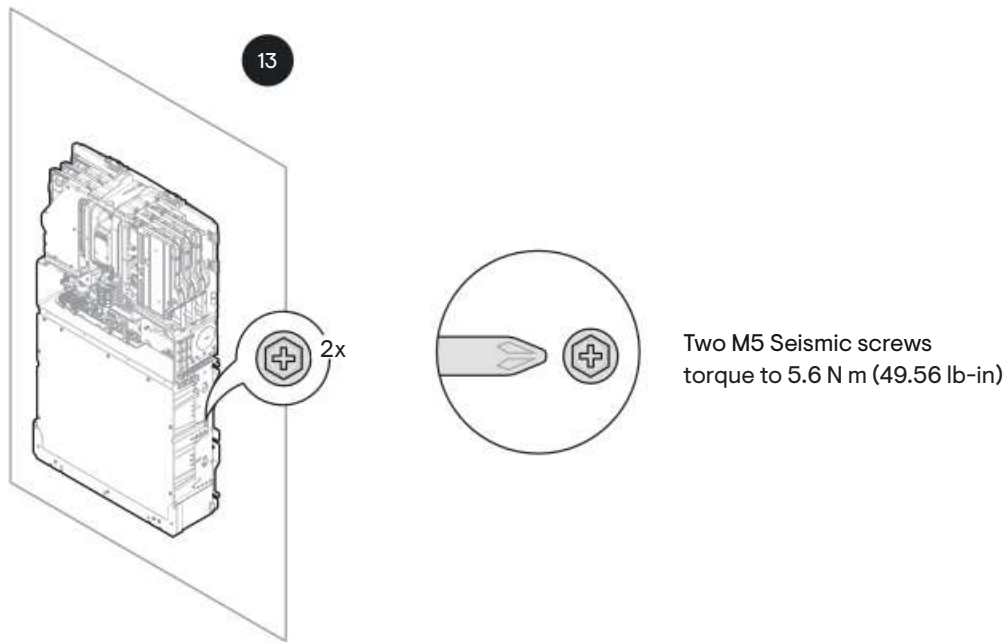

Secure the battery unit on the bottom mounting bracket using two M5 Seismic screws. This is required to comply with seismic requirements.

✔ **NOTE:** Use an electric drive; do not use impact drives/ impact drills while tightening seismic screws.

✔ **NOTE:** It is recommended to use a screwdriver extension bit to reach the screw head.

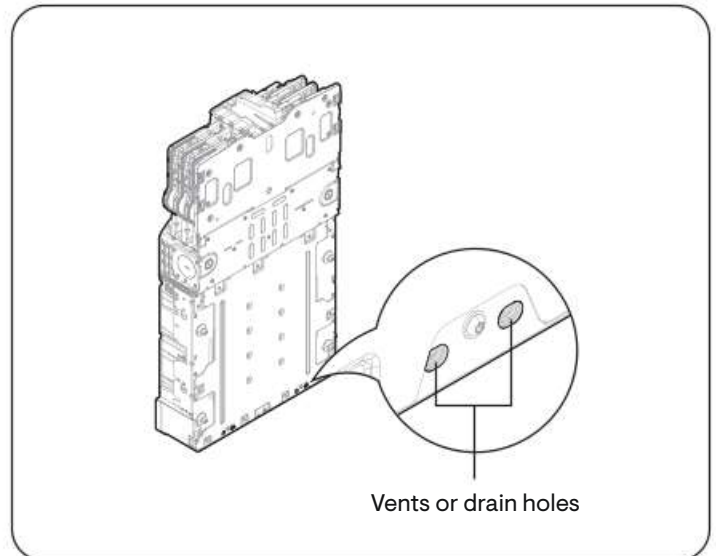

⚠ **WARNING:** The vent or drain holes provided at the back of the unit serve the dual purpose of natural ventilation and condensation drainage. Blocking these holes can affect the functionality of the product.

## Section B - Installing IQ Battery 5P

### Installation of Anchor Clip

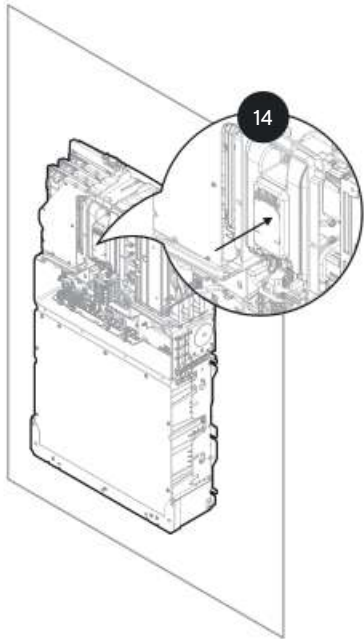

Push against the wiring cover and hold the IQ Battery 5P top section as close to the wall as possible.

 **WARNING:** Do not push from PCUs to avoid any damage.

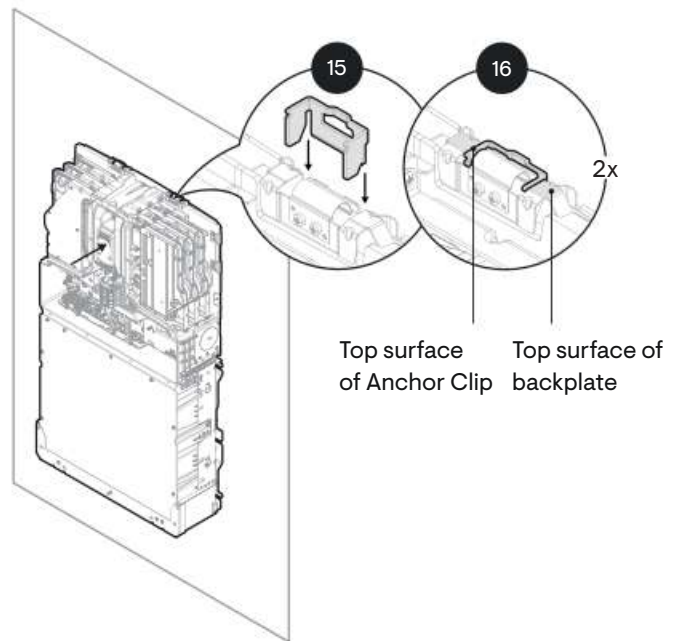

Install two Anchor Clips to secure the top section of the IQ Battery 5P to the wall. Slide the anchor clip downwards until the top surface of the clip coincides with the top surface of the IQ Battery 5P backplate. This ensures no obstructions during the IQ Battery 5P cover installation.

## Section C

# Wiring

## Install conduits and field wiring

1. When installing a single IQ Battery 5P unit, insert the conduit in the cutouts drilled in the previous step.

✔ **NOTE:** When upgrading an IQ Battery 5P site with a new unit, disconnect B1 and B2 (DC connectors) on the adjacent IQ Battery 5P (units).

✔ **NOTE:** Use a “chase nipple” and “rigid coupling” as spacers for connecting 90° fitting to the battery. This avoids interference between the 90° fitting and battery ID cover. Ensure the joints are properly fastened and are watertight.

2. If installing more than one IQ Battery 5P, insert the conduit on the side of the unit closest to the AC disconnect. If an IQ System Controller is in line of sight, the breaker on IQ System Controller can service as the AC disconnect.

✔ **NOTE:** Follow the steps below when installing rigid conduits between units:

- a. Mount only one IQ Battery 5P on the wall.
- b. Add rigid conduit to it.
- c. Adjust the rigid conduit in the first unit as required and mount the second IQ Battery 5P on the wall.
- d. Repeat steps a, b, and c for mounting additional IQ Battery(ies).

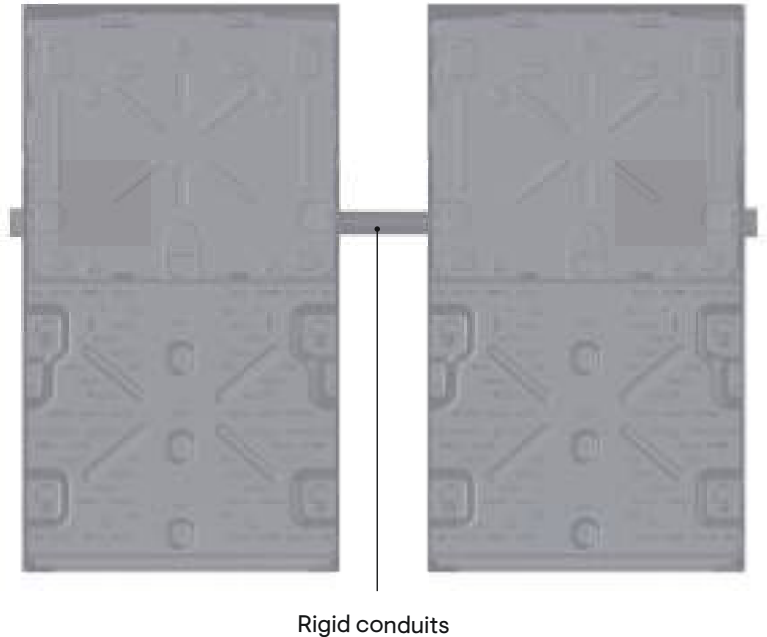

## Section C - Wiring

- Starting from the unit closest to the IQ System Controller 3/3G, pass the power and control communication conductors through the conduit and make the two ends of conductors available on the unit and IQ System Controller 3/3G side.
- Connect the power conductors and control communication cables on the terminal blocks (L1, L2, and Ground) and the control communication connector, respectively. Each terminal block accepts 10–3 AWG conductors for L1 and L2 terminals. Tighten L1 and L2 terminals to 2.5 N m (27 lb-in) and small Ground terminal to 1.5 N m (13.2 lb-in).

✔ **NOTE:** Do not disturb the factory termination connections on terminal blocks during field wiring.

- If connecting more than one IQ Battery 5P, connect power conductors between the terminal blocks and control communication cables between the CTRL connectors of these units such that the conductors connect on the right side of one unit and the left side of another unit after passing through the conduit. Repeat these steps until you arrive at the unit that is farthest from the IQ System Controller 3/3G.

✔ **NOTE:** Power and control communication cables will run in parallel through conduits.

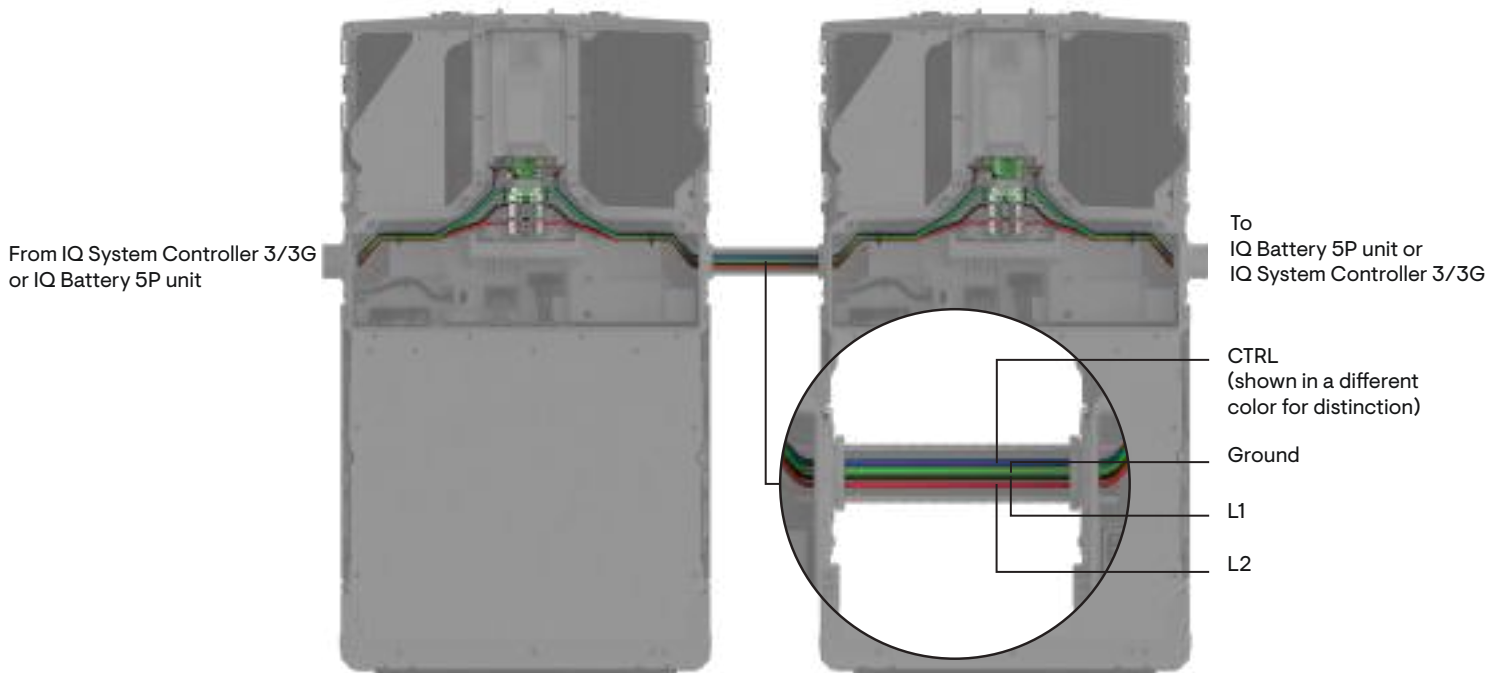

## Section C - Wiring

6. Follow the jacket stripping length and connect the control communication wires to the 4-pin connectors as per the color code shown in the following image. Keep the terminating resistor only on the devices that are on the two ends of the control communication bus and remove the resistor from the rest of the devices. (refer to the next page for details).

Enphase SKU for control cable: CTRL-SC3-NA-01

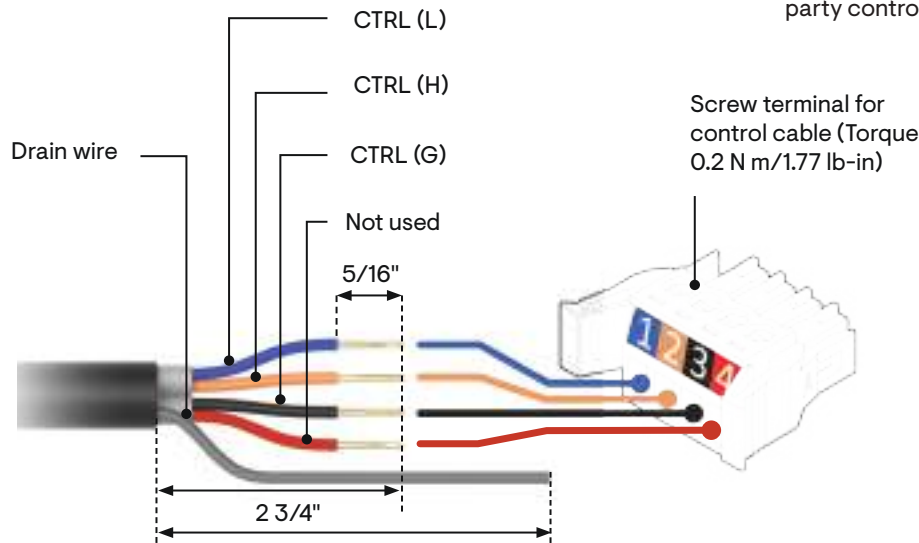

4 3/4 in length for the drain wire coming from the cable landing on the control header on the right or 2 1/8 in length for the drain wire coming from the cable landing on the control header on the left.

- NOTE: You may leave the 4th CTRL cable (red cable) unconnected too, as advised in the previous revisions of this quick install guide.

- NOTE: The control cable required for IQ Battery 5P, IQ Combiner 5/5C, and IQ System Controller 3/3G must be compliant with UL 3003, UL 1277, and UL 83 standards. The Enphase Control Cable (SKU: CTRL-SC3-NA-01) has optimal impedance and has been validated for optimal system performance. Third-party cables may not have the correct characteristic impedance, and consequently, may not work reliably. Enphase cannot guarantee performance when a third-party control cable is used.

- NOTE: Use the following tool to strip the jacket of control communication cable.

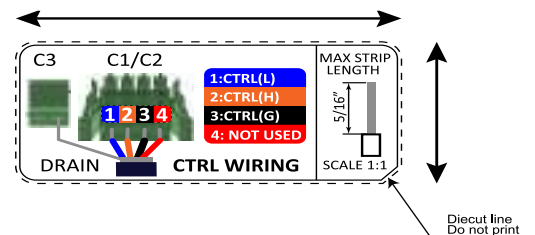
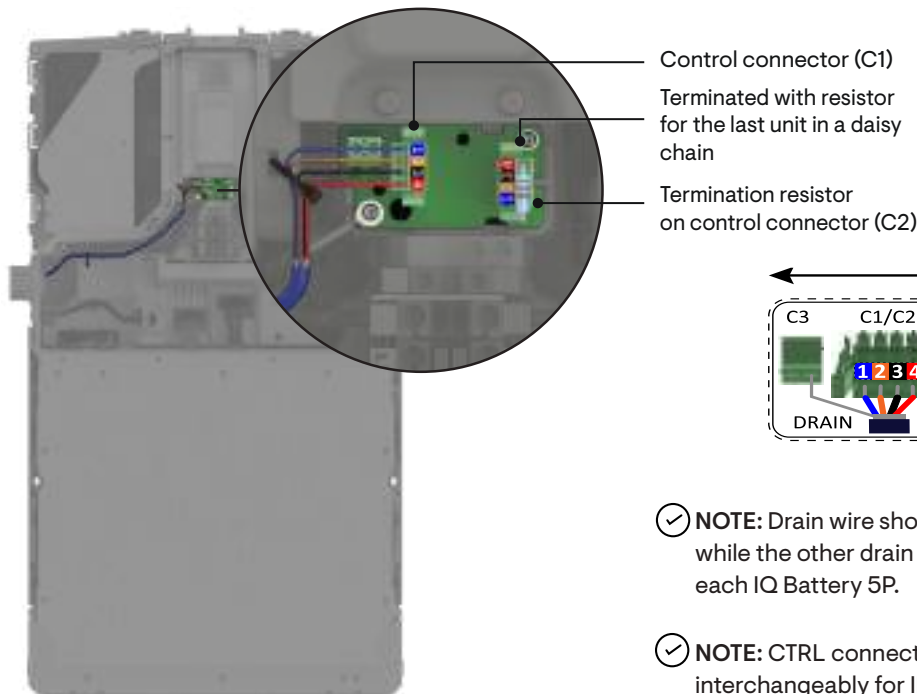

- NOTE: Drain wire should be terminated only at one drain connector while the other drain connector shall remain unconnected within each IQ Battery 5P.

- NOTE: CTRL connectors (C1/C2) are identical and can be used interchangeably for IN and OUT connections.

## Section C - Wiring

# Control (CTRL) wiring between system components

Control wiring guidance for the Enphase Energy System.

Refer to the following wiring sequences to understand the position of the header with termination resistor, wiring order, and drain wire termination location.

☑ **NOTE:** Ensure the following guidelines are followed to avoid failures during system commissioning:

1. One header with a termination resistor should be installed on each component that is at the extreme end of the control network.
2. The drain wire should only be terminated on one end of the control wiring between system components. Connecting drain wires at both ends of the section can result in communication issues.
3. Do not wire the System Shutdown (SSD) Switch 4-wire cables to the control cable header. Doing so will result in a communication breakdown of the Enphase Energy System.
4. It is recommended that the drain wire be terminated at the component from which control wiring for the section is initiated.
5. The same conduits can be used for power and control wire routing only when using an Enphase Control Cable, i.e., CTRL-SC3-NA-01.
6. Ensure to strip the conductor for control cable length to allow for the drain wire to adequately reach the drain port on one side of the cable only.

The following are four common wiring sequences:

### Sequence 1a:

IQ Combiner 5/5C > IQ System Controller 3G > IQ Battery(s) 5P

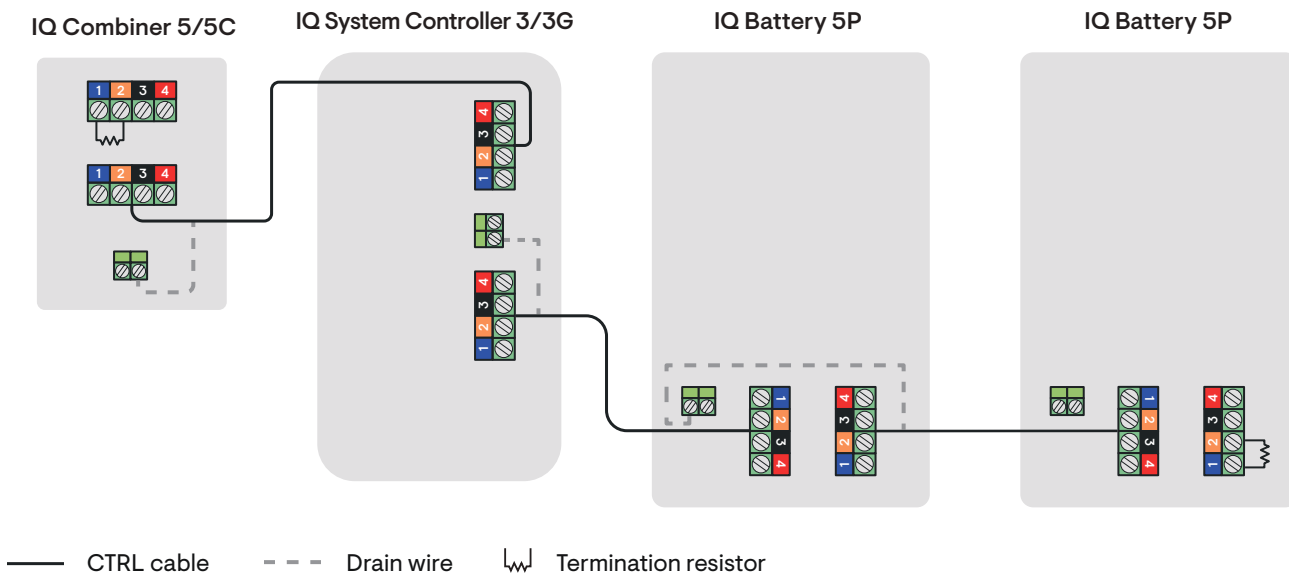

☑ **NOTE:** The total length of CTRL wiring across the system cannot exceed 250 ft to ensure the system operates as per specifications.

⚠ **WARNING:** The drain wire should only be terminated on one end of the control wiring between the system components.

# Section C - Wiring

## Sequence 1b:

IQ Combiner 5/5C > IQ System Controller 3 > IQ Battery(s) 5P (this is only applicable to IQ System Controller 3, where a third DER port can be used for additional batteries)

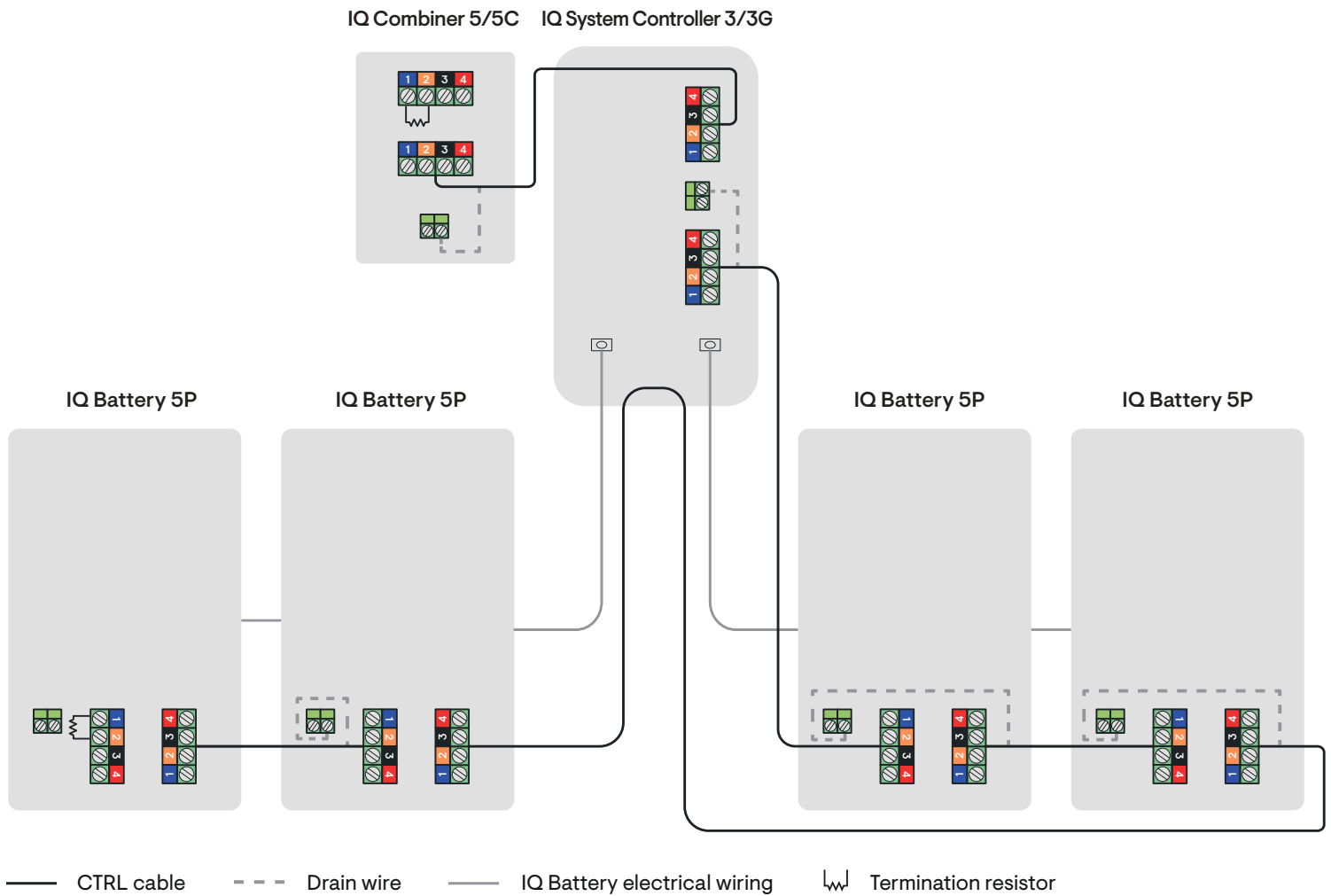

✔ **NOTE:** The total length of CTRL wiring across the system cannot exceed 250 ft to ensure the system operates as per specifications.

⚠ **WARNING:** The drain wire should only be terminated on one end of the control wiring between the system components.

## Section C - Wiring

### Sequence 2: IQ Combiner 5/5C > IQ Battery(s) 5P > IQ System Controller 3/3G

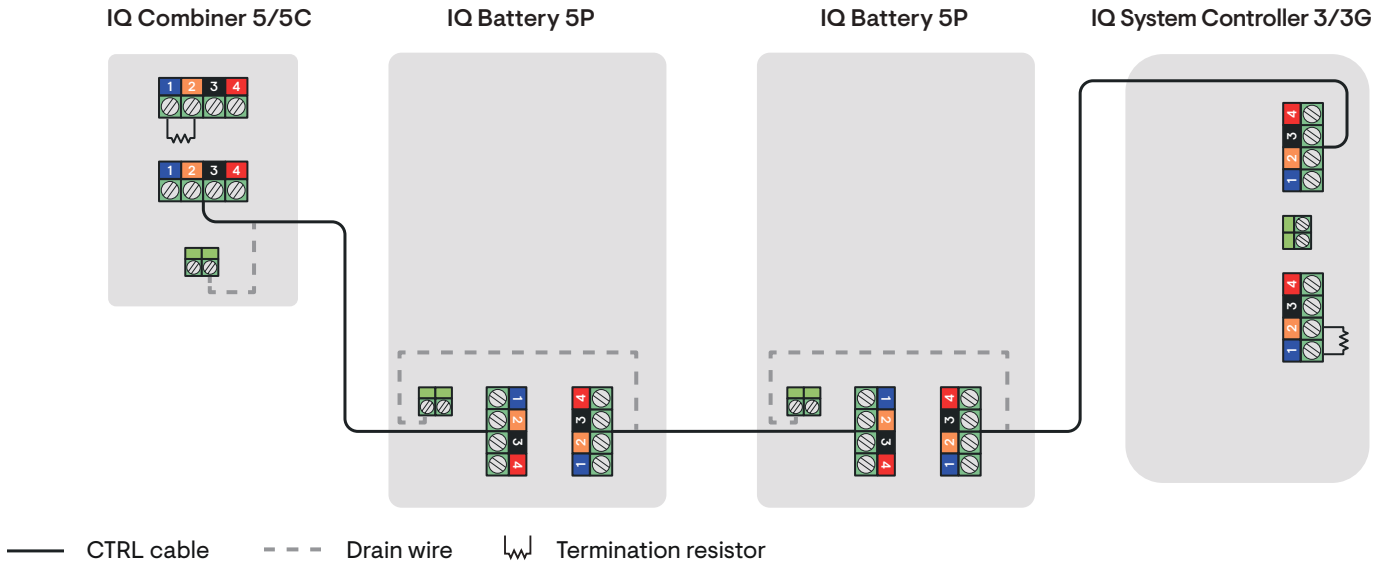

✔ **NOTE:** The total length of CTRL wiring across the system cannot exceed 250 ft to ensure the system operates as per specifications.

⚠ **WARNING:** The drain wire should only be terminated on one end of the control wiring between the system components.

### Sequence 3: IQ System Controller 3/3G > IQ Combiner 5/5C > IQ Battery(s) 5P

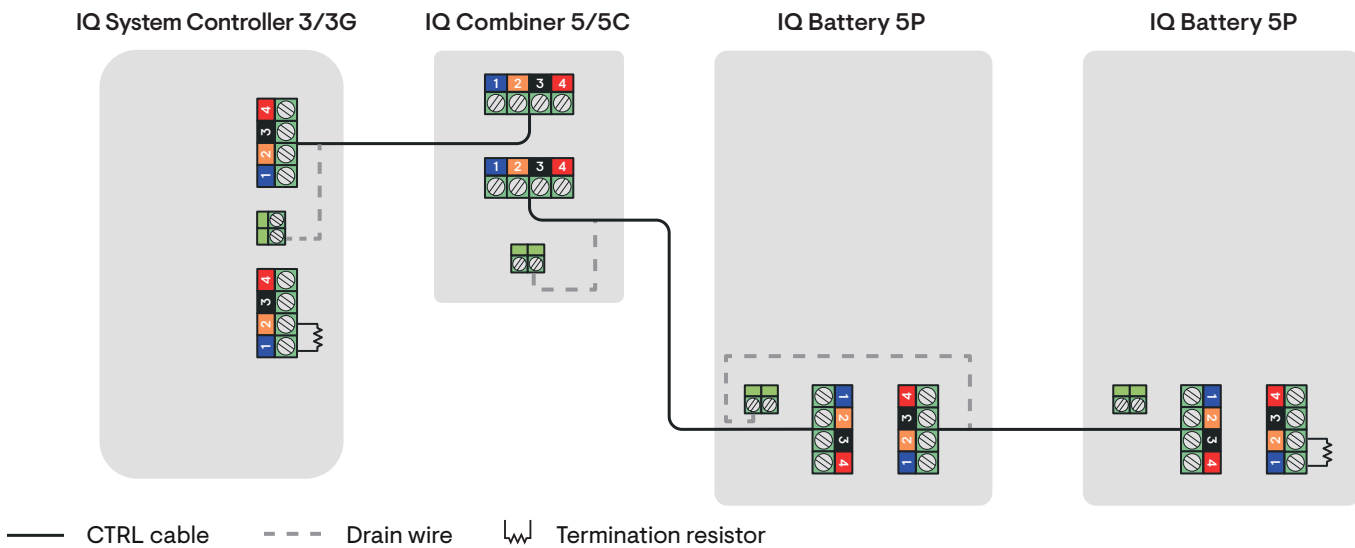

✔ **NOTE:** The total length of CTRL wiring across the system cannot exceed 250 ft to ensure the system operates as per specifications.

⚠ **WARNING:** The drain wire should only be terminated on one end of the control wiring between the system components.

## Section C - Wiring

Here is a table providing termination resistor locations for the above sequences:

CONTROL WIRING SEQUENCE	TERMINATION RESISTOR LOCATION
IQ Combiner 5/5C > IQ System Controller 3G > IQ Battery(s) 5P	<ol style="list-style-type: none"> <li>1. IQ Combiner 5/5C</li> <li>2. Last IQ Battery 5P in the daisy chain</li> </ol>
IQ Combiner 5/5C > IQ System Controller 3 > IQ Battery(s) 5P	<ol style="list-style-type: none"> <li>1. IQ Combiner 5/5C</li> <li>2. Last IQ Battery 5P in the daisy chain (this last battery can be on either DER circuit for IQ Battery or generator)</li> </ol>
IQ Combiner 5/5C > IQ Battery(s) 5P > IQ System Controller 3/3G	<ol style="list-style-type: none"> <li>1. IQ Combiner 5/5C</li> <li>2. IQ System Controller 3/3G</li> </ol>
IQ System Controller 3/3G > IQ Combiner 5/5C > IQ Battery(s) 5P	<ol style="list-style-type: none"> <li>1. IQ System Controller 3/3G</li> <li>2. Last IQ Battery 5P in the daisy chain</li> </ol>

## Section C - Wiring

# Cable routing and closing the wiring cover

1. Route the conductors between conduit and terminal blocks using anchoring points as shown in the following figure:

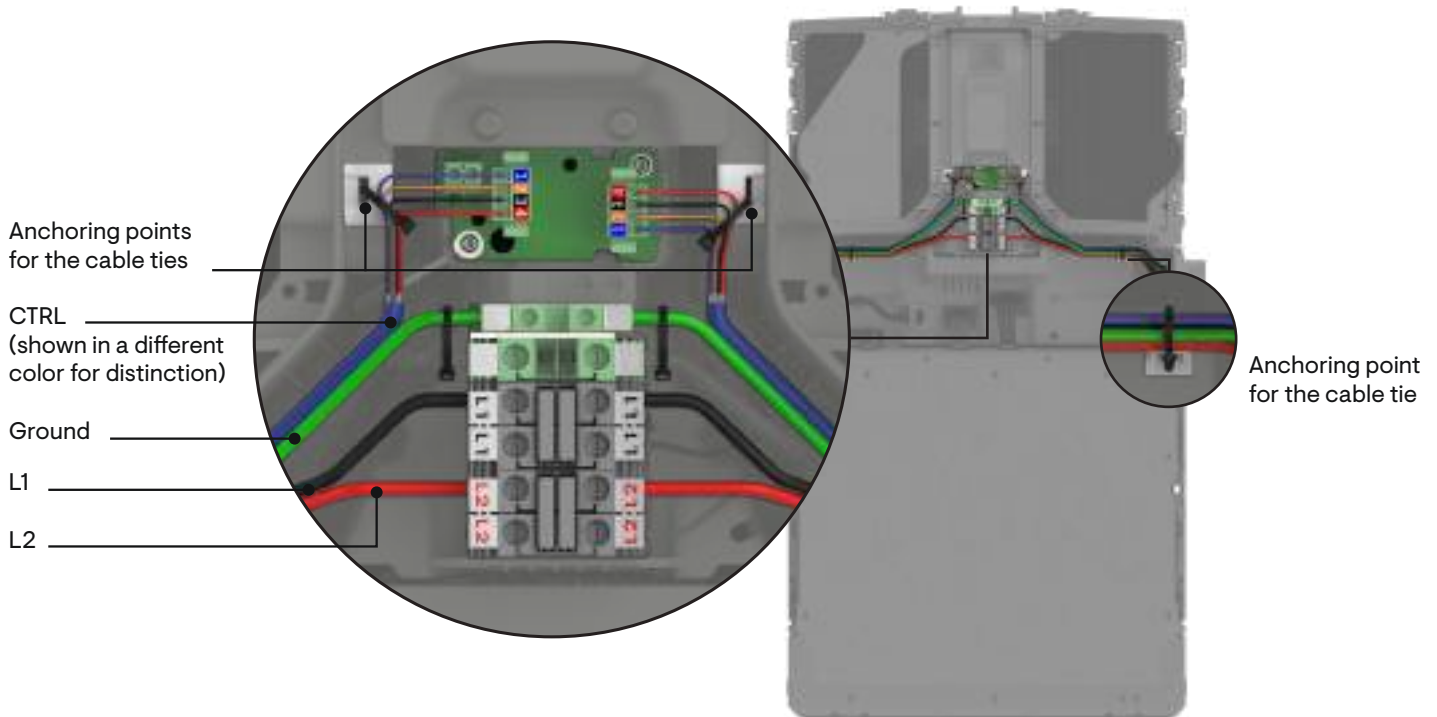

**⚠ WARNING:** Ensure the drain wires do not come in contact with any live connection.

**✓ NOTE:** Cable ties are available in the accessories kit inside the packaging box. Anchor the cables as shown to ensure the proper cable routing, avoid wire separation from the terminals, and provide unrestricted access for the wiring cover assembly.

2. After all wires in the field wiring compartment are connected and secured, ensure there are no exposed conductors.
3. Ensure the IQ Battery 5P unit is farthest from IQ System Controller 3/3G has a cutout only on one side, and all other sides are covered.
4. Apply AC power to the IQ Battery 5P circuits. Using a voltmeter, ensure the voltage between L1 and L2 on the terminal blocks of each IQ Battery 5P unit measures 240 VAC 208 VAC depending on the grid voltage.
5. If the voltage is within the range as required by local codes, turn off the AC power supply.

## Section C - Wiring

6. Connect the following connectors to the BMS board:
- B1: Battery DC positive connector termination
  - B2: Battery DC negative connector termination
  - CS1: Control switch intermediate connector termination

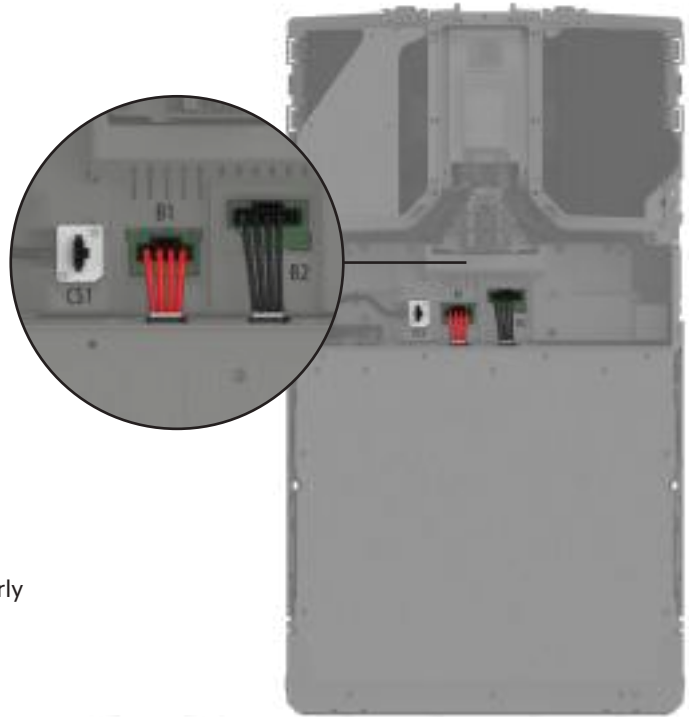

✔ **NOTE:** Connect CS1 at last to avoid damage to the wiring cover.

⚠ **WARNING:** Ensure that all the connectors are latched properly and that a clicking sound is heard.

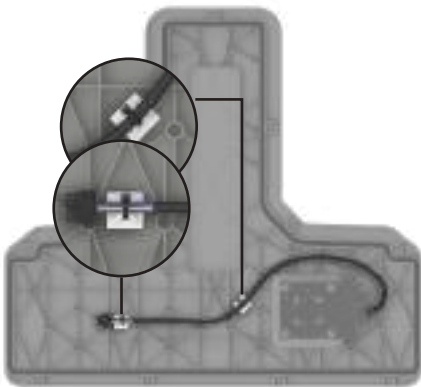

Cut two cable ties and insert the connector on CS1 in BMS board

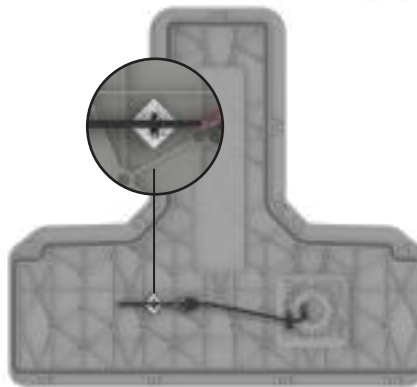

Cut one cable tie and insert the connector on CS1 in the BMS board



✔ **NOTE:** There are two variants of the control switch available in IQ Battery 5P. The control switch cable is secured to the wiring cover using cable ties. Select the control switch available at the site based on the images below and cut the cable ties on the wiring cover to access the control switch cable.

## Section C - Wiring

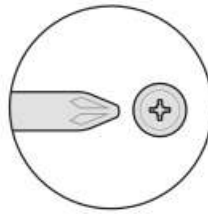
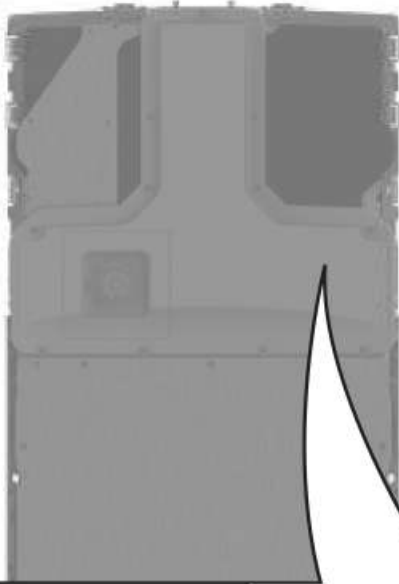
- Fasten the 11 captive screws at the wiring cover as shown.  
Use an electric drive; do not use impact drives/impact drills.

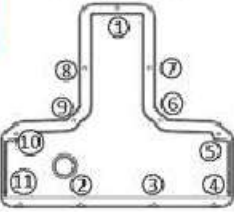

Refer to the red caution label on unit for torque value

 <b>WARNING</b>		 <b>AVERTISSEMENT</b>	
<b>RISK OF ELECTRIC SHOCK</b> DO NOT REMOVE THIS COVER. SERVICE WORK SHOULD ONLY BE PERFORMED BY A QUALIFIED PERSON.		<b>RISQUE D'ÉLECTROCUTION</b> NE PAS RETIRER LE CARÉNAGE ; SEUL UN TECHNICIEN QUALIFIÉ EST HABILITÉ À RÉPARER OU À ENTREtenir CET APPAREIL.	
 <b>CAUTION!</b> FOLLOW THE SEQUENCE SHOWN TO PARTIALLY TORQUE THE 11x SCREWS. FULLY TORQUE ALL THE SCREWS TO <span style="background-color: white; border: 1px solid black; padding: 0 5px;"> </span> Nm AT MAX 1000RPM, ONLY AFTER ALL OF THEM ARE IN POSITION.			
<b>INSTRUCTIONS TO REMOVE THE WIRING COVER PRIOR TO INSTALLATION / SERVICING</b> 1. LOOSEN THE 11x SCREWS TO REMOVE THE WIRING COVER FOR INSTALLATION/ SERVICING. REFER QIG FOR MORE DETAILS. 2. FOR SERVICING, MOVE THE WIRING COVER GENTLY AWAY FROM THE UNIT TO FIND THE CONTROL SWITCH (CS1) INTERMEDIATE CONNECTION AND UNPLUG IT FROM THE PANEL MOUNT CONNECTOR BEFORE REMOVING WIRING COVER COMPLETELY.		<b>INSTRUCTIONS TO ASSEMBLE THE WIRING COVER AFTER INSTALLATION / SERVICING</b> 1. PLUG THE CONTROL SWITCH INTERMEDIATE CONNECTOR (CS1) TO THE PANEL MOUNT CONNECTOR AND ENSURE THAT THE CABLE IS ROUTED INSIDE THE UNIT PROPERLY BEFORE ASSEMBLING THE WIRING COVER COMPLETELY. 2. FASTEN THE SCREWS AS PER ABOVE INSTRUCTIONS. REFER QIG FOR MORE DETAILS.	
			<b>DO NOT USE IMPACT DRIVES AND DRILLS TO FASTEN/ LOOSEN THE SCREWS</b>
			<b>SCREW FASTENING SEQUENCE</b> 

## Section C - Installing the current transformers

# IQ Battery metering

One clamp-style current transformer (CT) is provided with the IQ Combiner 5/5C for IQ Battery 5P metering.

The CTs are installed in the IQ Combiner 5/5C for grid-tied systems and in the IQ System Controller for grid-forming systems.



## IQ Battery 5P metering for grid-tied systems

For grid-tied sites, IQ Battery 5P can be installed in the IQ Combiner 5/5C.

The IQ Battery CT needs to be installed on the L2 line of the IQ Battery with the arrow pointing towards the breaker in the IQ Combiner 5/5C.

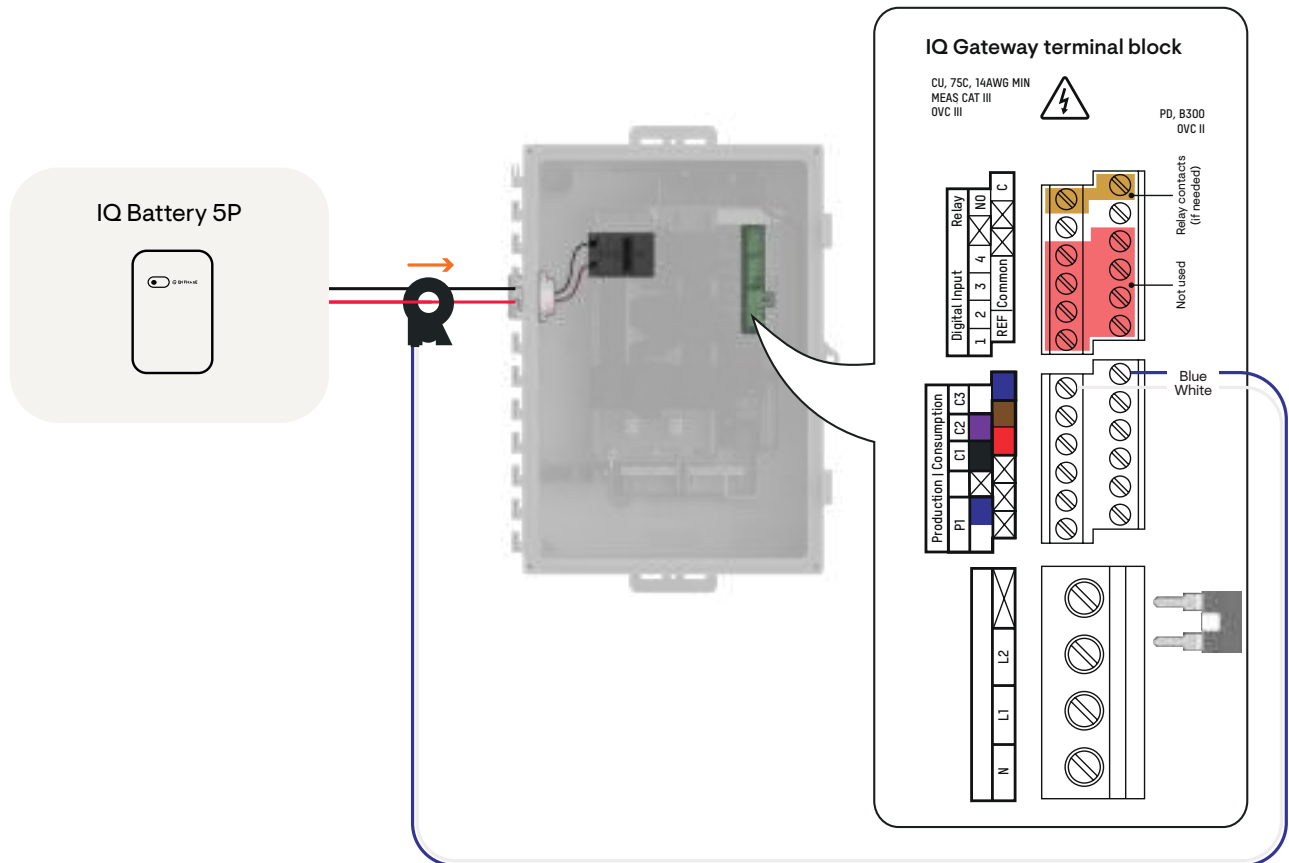

**⚠ WARNING:** Risk of electrocution and equipment damage! Do not install CTs when current is flowing in the sensed circuit. Always install CT wires in the terminal blocks before energizing the sensed circuit.

# Section C - Installing the current transformers

## IQ Battery 5P metering for grid-forming systems

For grid-forming systems, IQ Battery 5P needs to be installed in the IQ System Controller 3/3G.

The IQ Battery CT needs to be installed on the L2 line of the IQ Battery with the arrow pointing towards the battery lugs in the IQ System Controller.

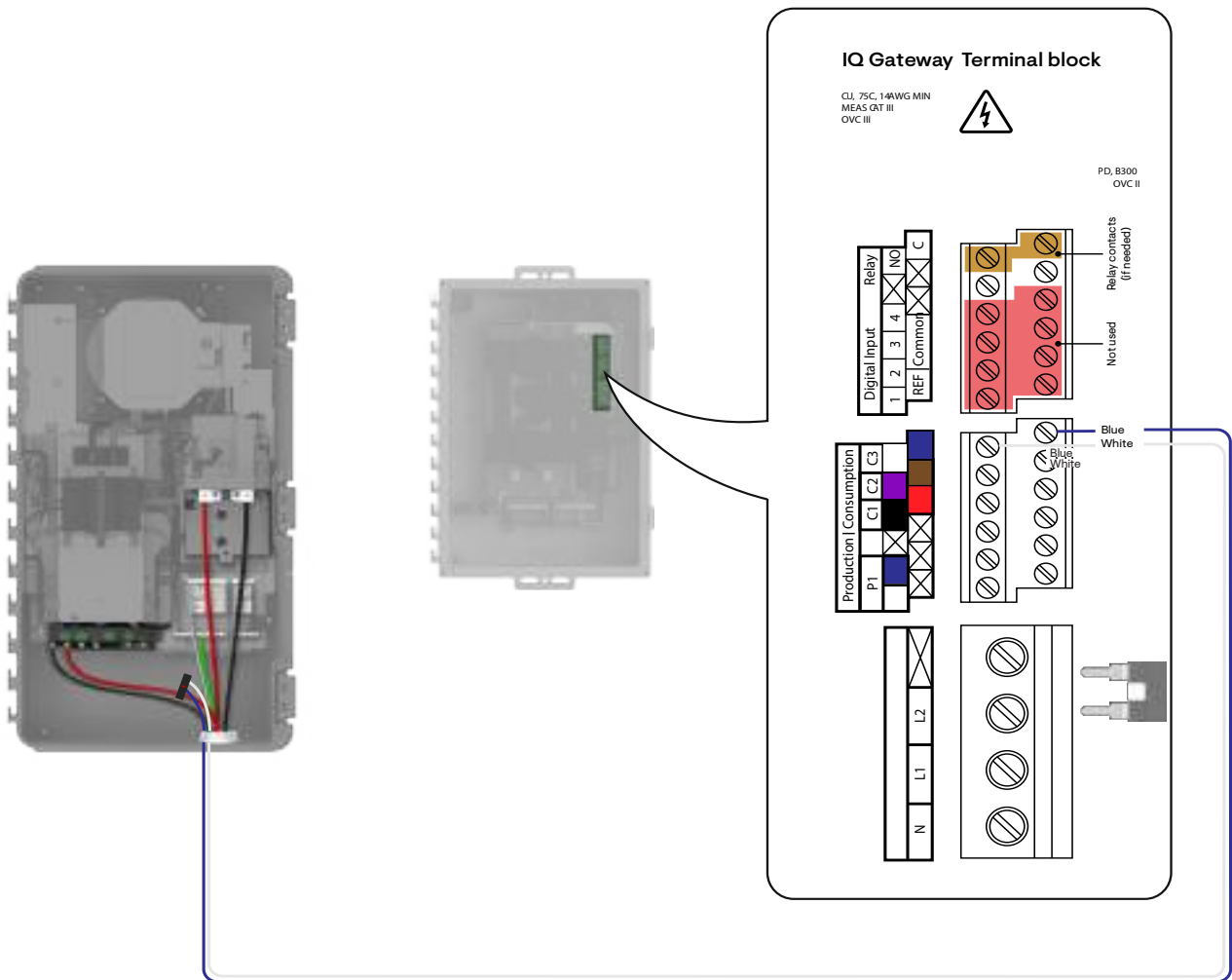

**⚠ WARNING:** Risk of electrocution and equipment damage! Do not install CTs when current is flowing in the sensed circuit. Always install CT wires in the terminal blocks before energizing the sensed circuit.

## Section D

# Close and energize the system

Ensure the wiring cover(s) for all IQ Batteries in the system are closed and secured.

**⚠ WARNING:** Before energizing, ensure that all IQ Batteries in the system are properly installed and conductors terminated.

**⚠ WARNING:** Risk of equipment damage. Ensure no wires are pinched before replacing the cover.

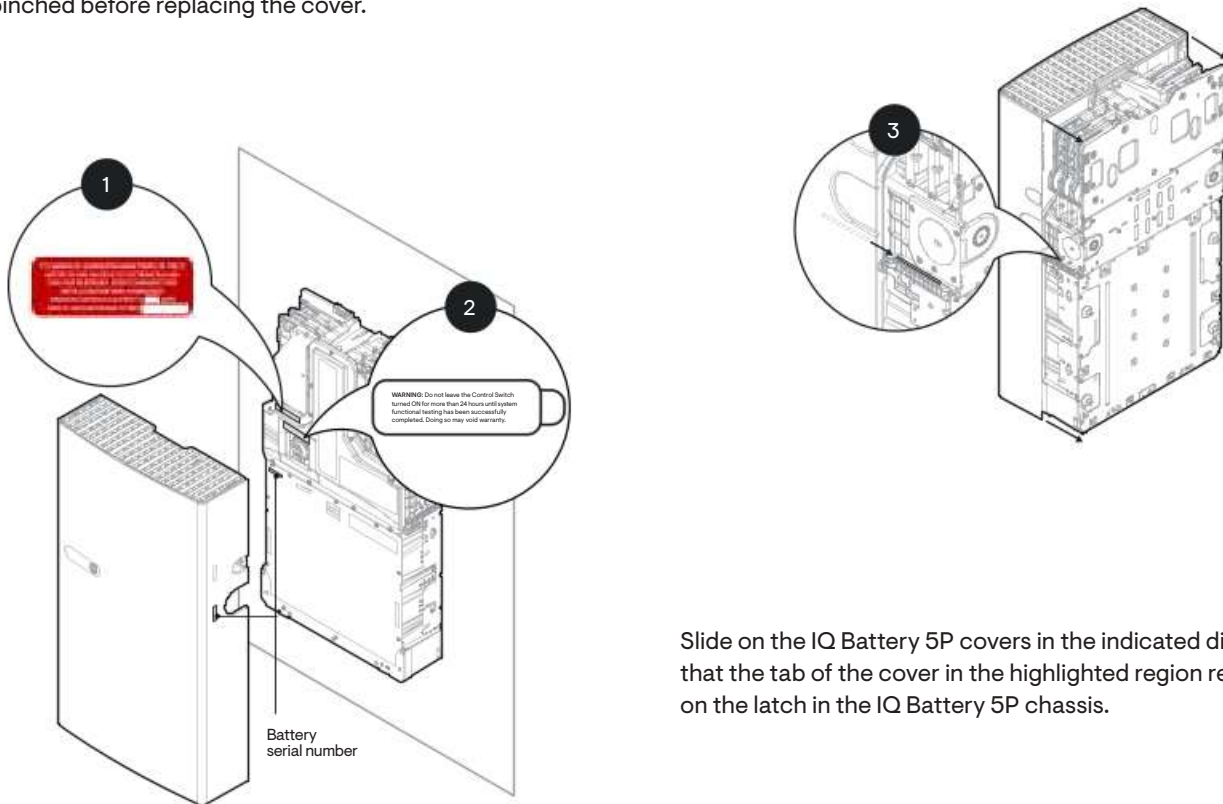

Slide on the IQ Battery 5P covers in the indicated direction such that the tab of the cover in the highlighted region rests and slides on the latch in the IQ Battery 5P chassis.

Peel off this sticker before installing the ID cover.

✔ **NOTE:** Paste the PCS disclaimer label on the wiring cover as shown above for all PCS-enabled IQ Battery 5P units.

✔ **NOTE:** Ensure the serial number label on the ID cover matches that on the heatsink before assembling the ID cover.

## Section D - Close and energize the system

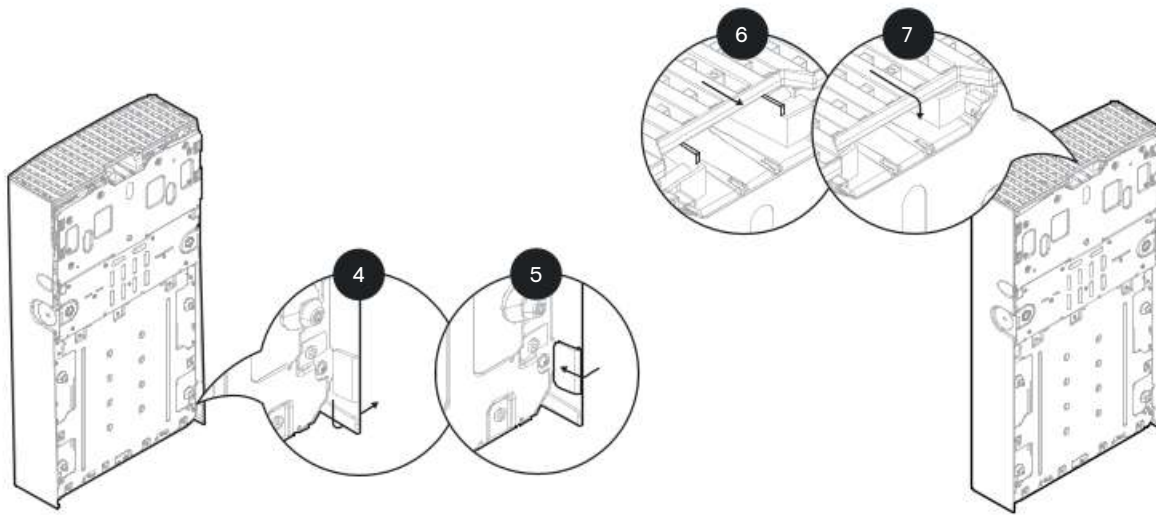

Before releasing, pull out the lower edges while sliding in the cover and ensure the tabs are locked to the back plate.

Push in the top portion of the cover as shown and ensure that the cover is locked in place.

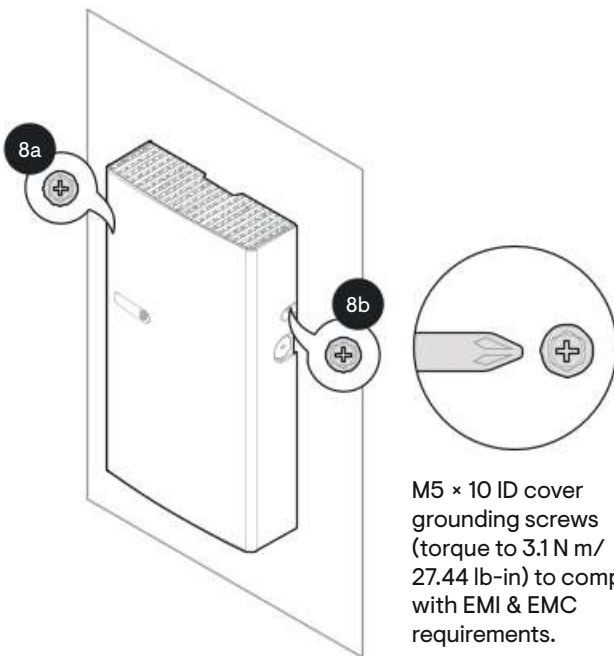

M5 × 10 ID cover grounding screws (torque to 3.1 N m/ 27.44 lb-in) to comply with EMI & EMC requirements.

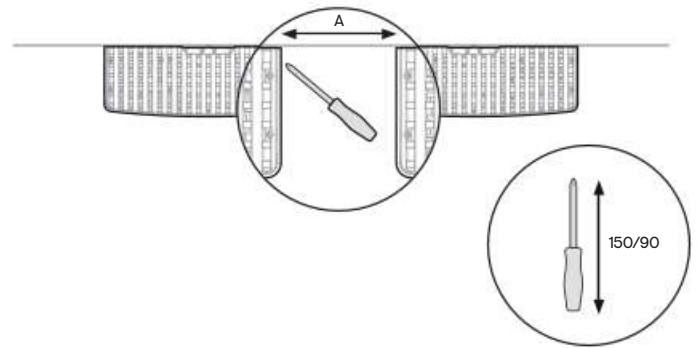

SCREWDRIVER OF MAXIMUM LENGTH 150 MM (5.91 IN)

Spacing 'A' between the units must be 5.5 in–6.5 in

Can access the screws at an angle.

SHORT STUB SCREWDRIVER OF MAXIMUM LENGTH 90 MM (3.54 IN)

Spacing 'A' between the units must be 3.0 in–5.5 in

Can access the screws at an angle.

Fasten the cover to the backplate.

**NOTE:** Use an electric drive; do not use impact drives/impact drills.

To fasten the cover to the backplate when two IQ Battery 5P units are placed close to each other, refer to the table.

## Section D - Close and energize the system

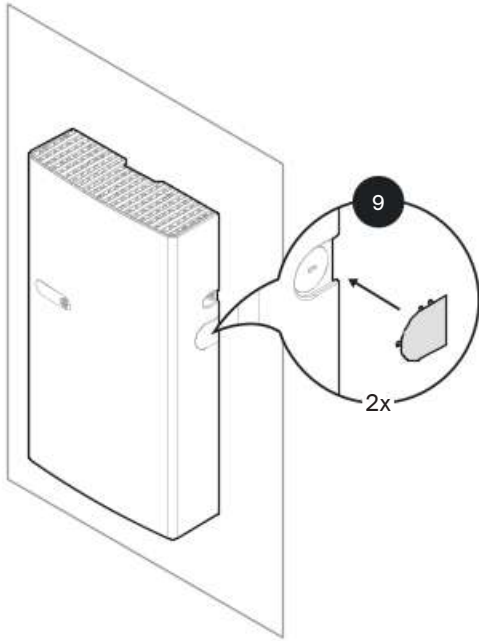

After installing the cover, the conduit cover should be installed to cover the opening in the IQ Battery 5P cover on the side.

If the conduit hub is installed, the conduit cover is not necessary on this side.

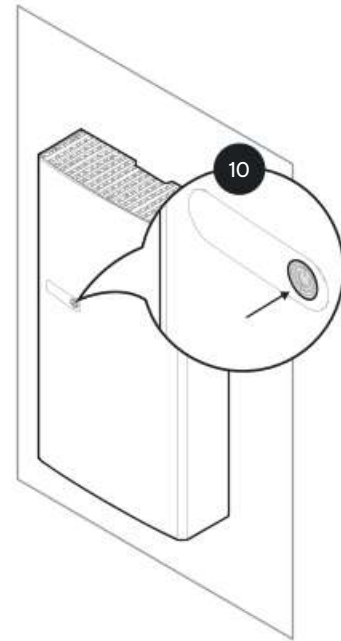

Apply AC power to the IQ Battery 5P circuits. Turn ON the DC control switch. A green LED will glow around the control switch. IQ Battery 5P is ready for commissioning.

**⚠ WARNING:** Do not leave the DC control switch in the ON position without an AC power supply available. This will deplete the battery and may lead to a condition where the battery cannot be turned ON and cannot be commissioned.

# Configure and activate

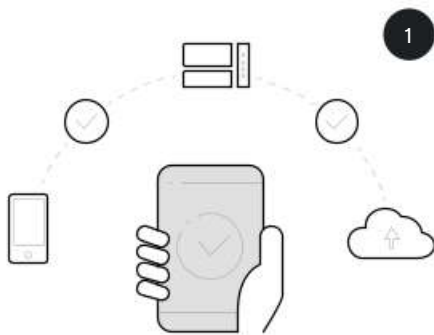

Use the Enphase Installer App to commission the IQ Battery(ies). Once connected to the IQ Gateway, refer to the Enphase Installer App help topics for more information.

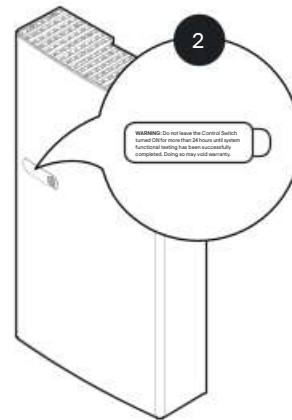

Peel off the sticker after the functional test is complete.

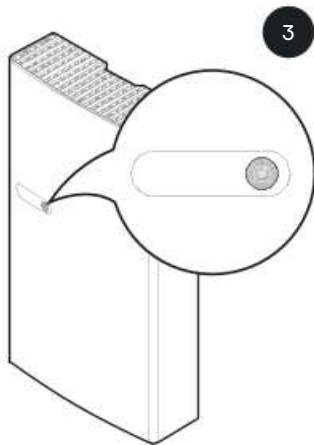

After the IQ Gateway has detected the IQ Battery(ies), the IQ Battery 5P LEDs operate as described in the following section.



Paste the additional nameplate label provided in the accessories bag on the IQ Battery 5P cover as shown.

# Disassembly of IQ Battery 5P cover

Refer to these instructions when you need to remove the cover.  
This is not a required step prior to commissioning.

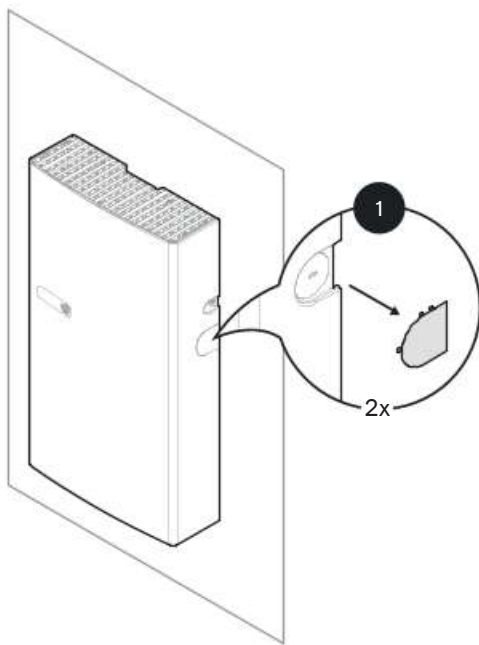

Remove the conduit covers from both sides of the IQ Battery 5P cover.

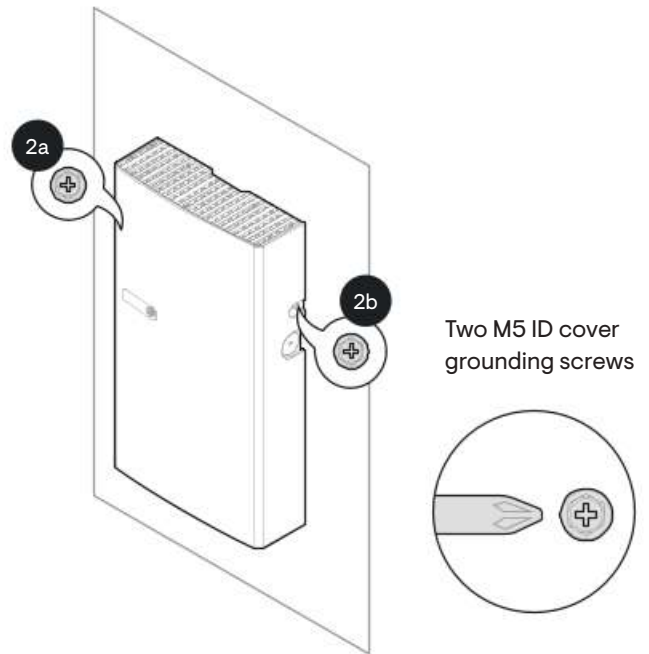

Remove the two M5 ID cover grounding screws that are used to affix the cover to the backplate.

✔ **NOTE:** Use electric drive; do not use impact drives/impact drills.

## Disassembly of IQ Battery 5P cover

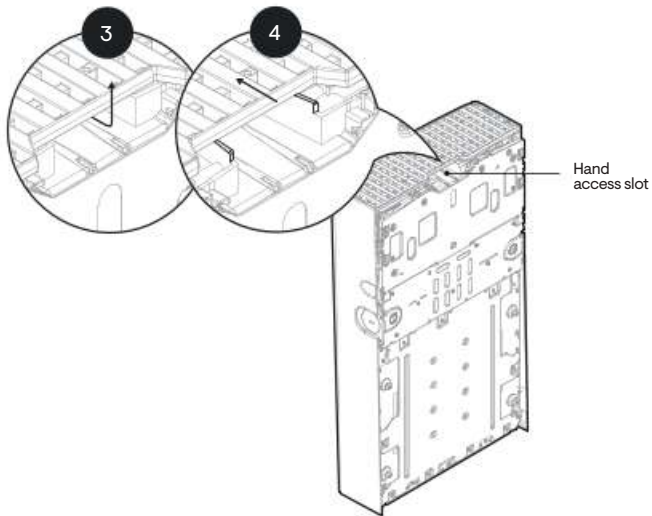

Using the hand access slot, pull the top plastic grill slightly, as shown in step 3.  
Unlock the top plastic cover from the ribs, as shown in step 4.  
Ensure the cover is slightly inclined after this step.

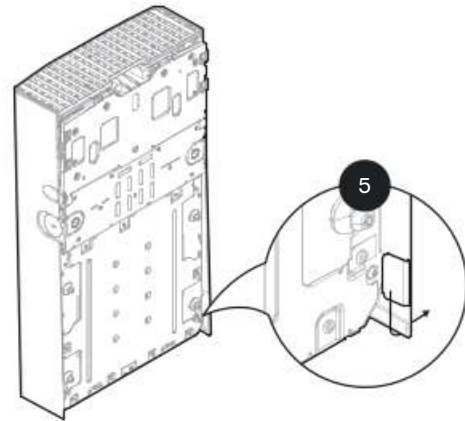

Pull out the lower portion of the cover in order to unlock the angular tabs and move it away from the wall slightly.

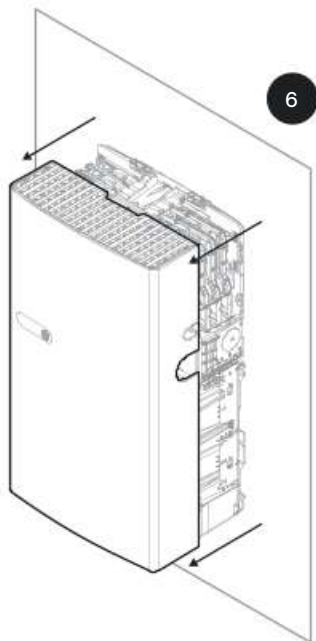

Pull the cover off in the indicated direction.

# Disengaging Anchor Clip

Refer to these instructions when you need to remove the Anchor Clip. This is not a required step prior to commissioning.

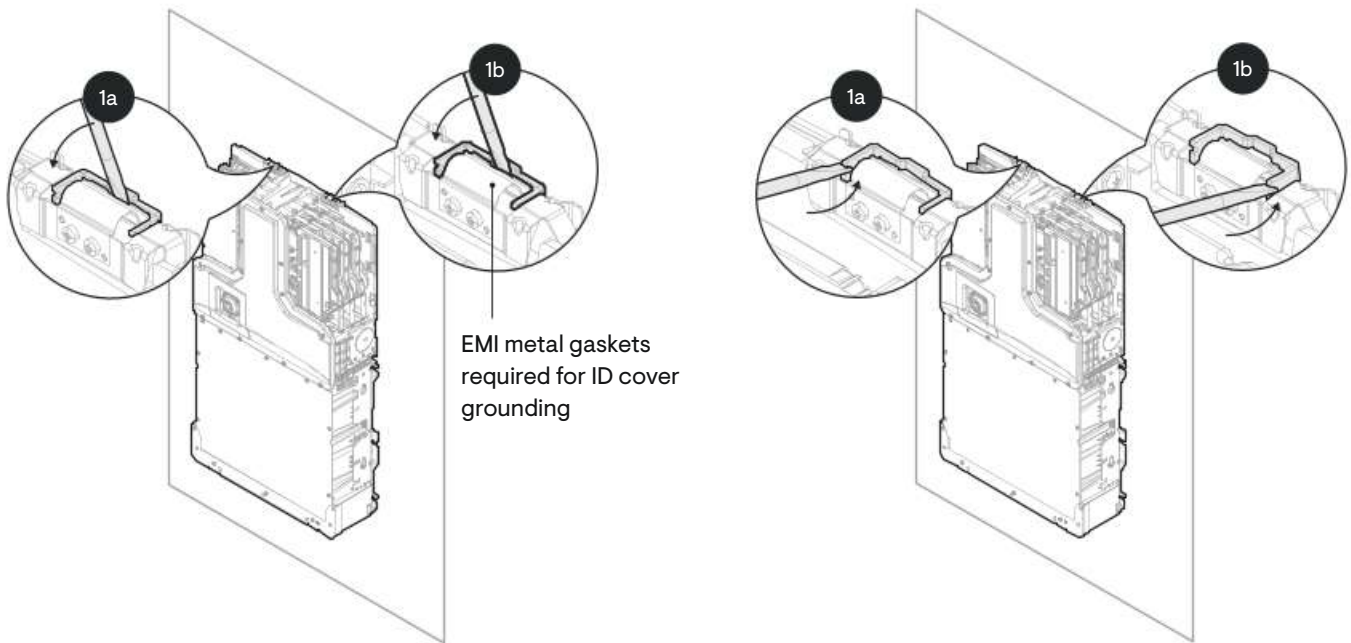

Disengaging of the Anchor Clip can be done by lifting it up using a flathead screwdriver or nose plier. Installers need to carefully insert the tool at the back slot, as shown below, and pull the clip upwards.

**⚠ WARNING:** Ensure not to touch or damage the EMI metal gaskets while removing the clips. EMI metal gaskets are delicate and need to be handled carefully.

Alternatively, Anchor Clips can also be lifted by using the front slots on either side of the clip using a flathead screwdriver.

# Operation

## LED overview

After being commissioned, the LED flashes yellow while each IQ Battery 5P boots up. If the LED rapidly flashes green for more than two minutes, the battery is in trickle charge mode and will remain so until it reaches a minimum state of charge (up to 30 minutes).

After IQ Battery 5P is booted up, the LED becomes blue or green, depending on the charge level. If the LED flashes yellow after one hour or changes to a flashing red state, contact Enphase Support at [enphase.com/contact/support](https://enphase.com/contact/support).

STATE	DESCRIPTION
<b>UNCOMMISSIONED</b>	
Flashing blue	After booting up, IQ Battery 5P has paired with an IQ Gateway but has not passed the commissioning three-way handshake to confirm that it is an Enphase device
Flashing green	After passing the three-way handshake with the IQ Gateway
<b>AFTER COMMISSIONING (NORMAL OPERATION)</b>	
Rapidly flashing yellow	Starting up/establishing communications
Red double flash	Error. See “Troubleshooting”
Solid yellow	Not operating due to high temperature. See “Troubleshooting”
Solid blue or green	Idle. Color transitions from blue to green as the state of charge increases. Check Enphase Installer Platform for charge status
Soft pulse blue	Discharging
Soft pulse green	Charging
Soft pulse yellow	Sleep Mode
Red triple flashes	DC switch OFF
Red one-second flash	Rapid shutdown mode
Off	Not operating. See “Troubleshooting”

# Operation

## Operating mode and set points

IQ Battery 5P supports multiple storage interactive system modes based on usage.

1. Using the Enphase App, select **Menu > Settings > Battery Storage**.
2. Select one of three battery modes:
  - Self-Consumption (default, no setting change required)
  - Savings
  - Full Backup (only supported in 240 V<sub>L-L</sub>/120 V<sub>L-N</sub> systems)

For more information on operation modes, refer to the storage system owner's guide at [enphase.com/en-us](https://enphase.com/en-us).



# Operation

## Troubleshooting

If the IQ Battery(ies) are not operating correctly, follow these troubleshooting steps. If the issue persists, contact Enphase at [enphase.com/contact/support](https://enphase.com/contact/support).

1. If the IQ Battery(ies) does not operate, check the temperature in the room and increase cooling and/or ventilation as required. Check that the bottom, top, and sides of IQ Battery 5P have at least 15 cm (6 in) clearance from the wall.
2. If the IQ Battery 5P LED is off, turn off the breaker for the branch circuit, wait for at least one minute, and turn it back on.

✔ **NOTE:** IQ Battery 5P has multiple field-replaceable parts. These must be replaced by trained service personnel. Contact Enphase Support before replacing any part.

✔ **NOTE:** During a brownout or blackout, IQ Battery 5P powers down automatically. This is normal. When power is restored, it automatically starts up again.

3. If you do not see IQ Battery 5P information in the Enphase App, check that the IQ Gateway and the internet connection are working.
4. If the issue persists, contact Enphase Support at <https://enphase.com/contact/support>.

### Limitation of Use:

Your IQ Battery 5P unit is not intended for use as a primary or backup power source for life-support systems, other medical equipment, or any other use where product failure could lead to injury, loss of life, or catastrophic property damage. Enphase disclaims any and all liability arising out of any such use of your IQ Battery 5P unit. Further, Enphase reserves the right to refuse to provide support in connection with any such use and disclaim any and all liability arising out of Enphase's provision of, or refusal to provide support for your IQ Battery 5P device in such circumstances.

# Safety

## IMPORTANT SAFETY INSTRUCTIONS. SAVE THESE INSTRUCTIONS.

This guide contains important instructions that you must follow during the installation and maintenance of the Enphase IQ Battery(ies).

Failing to follow any of these instructions may void the warranty ([enphase.com/warranty](https://enphase.com/warranty)). Refer to the MSDS document and safety data sheet at [enphase.com/en-us](https://enphase.com/en-us).

## In case of fire or other emergency

### In all cases:

- If safe to do so, switch off the AC breaker for the IQ Battery 5P circuit, and if an isolator switch is present, switch off the AC isolator for the IQ Battery 5P circuit.
- Contact the fire department or other required emergency response team.
- Evacuate the area.
- Contact Enphase Support at <https://enphase.com/contact/support>.

### In case of fire:

- When safe, use a fire extinguisher. Suitable types are A, B, and C dry chemical fire extinguishers. Additional extinguishing media include carbon dioxide or alcohol-resistant foams.

### In case of flooding:

- Stay out of the water if any part of the IQ Battery(ies) or wiring is submerged.
- If possible, protect the system by finding and stopping the source of the water and pumping it away.
- If water has contacted the battery, call your installer to arrange an inspection. If you are sure that water has never contacted the battery, let the area dry completely before use.

### In case of unusual noise, smell, or smoke:

- Ensure nothing is in contact with the IQ Battery(ies) or in the venting area of the IQ Battery(ies).
- Ventilate the room.



### In case of electrolyte exposure:

The Enphase IQ Battery 5P has a lithium iron phosphate (LFP) battery that contains organic electrolytes and is sealed in a protective case. The leaked electrolyte is toxic and highly flammable. The leaked electrolyte is colorless and has a sweet odor. Electrolyte fluid tends to evaporate quickly, leaving behind a white grainy substance. If an odor is obvious, proceed to the following steps:











#### **DANGER: DO NOT TOUCH OR INGEST ANY LIQUID SUSPECTED TO BE BATTERY ELECTROLYTE.**

- Evacuate personnel to a safe area and keep unauthorized personnel away.
- Isolate the spill area to a minimum distance of 75 ft (25 m).
- Eliminate all ignition sources (no smoking, sparks, flames, or hot equipment) in the immediate area around the spill.
- Do not touch or walk through spilled material.
- Avoid breathing vapors. Ensure adequate ventilation.
- Use personal protective equipment.
- Emergency telephone number (ChemTel):
  - Inside United States Territories and Canada: (800) 255-3924
  - Outside United States Territories and Canada: +01 (813) 248-0585















## Safety and advisory symbols

-  **DANGER:** This indicates a hazardous situation, which, if not avoided, will result in death or serious injury.
-  **WARNING:** This indicates a situation where failure to follow instructions may be a safety hazard or cause equipment malfunction. Use extreme caution and follow instructions carefully.
-  **NOTE:** This indicates information particularly important for optimal system operation. Follow instructions carefully.













## Safety instructions

-  **DANGER:** Risk of electric shock. Risk of fire. Only qualified electricians should install, troubleshoot, or replace the IQ Battery(ies).
-  **DANGER:** Risk of fire or explosion. Only qualified personnel using personal protective equipment (PPE) should transport or handle the IQ Battery(ies).
-  **DANGER:** Risk of explosion. Do not dispose of IQ Battery(ies) in a fire or by burning. The IQ Battery(ies) can explode.
-  **DANGER:** Risk of fire or explosion. This product is designed for stationary installation only and should be used accordingly. It is not designed for mobile applications such as installation on vehicles and trailers and should not be used in such applications.
-  **DANGER:** Risk of fire. During use, when stored, or during transport, keep the IQ Battery(ies) in an area that is well-ventilated and protected from the elements, where the ambient temperature and humidity are within -4°F to 131°F (-20°C to 55°C) and 5% to 95% RH, non-condensing, preferably out of direct sunlight. Do not install the IQ Battery(ies) at elevations over 8,200 ft (2,500 m) above sea level.
-  **DANGER:** Risk of fire. If the IQ Battery(ies) generate smoke, remove AC power from the Enphase system and turn the DC control switch to the off position so that charging/discharging stops.
-  **DANGER:** Risk of electric shock. Do not use Enphase equipment in a manner not specified by the manufacturer. Doing so may cause death or injury to persons or damage to equipment.
-  **DANGER:** Risk of electric shock. Do not install the IQ Battery(ies) without first removing AC power from the photovoltaic system. Disconnect the power coming from the photovoltaics before servicing or installing.
-  **DANGER:** Risk of electric shock. Always de-energize the AC branch circuit during an emergency and/or before servicing the IQ Battery(ies).
-  **DANGER:** Risk of electric shock. Risk of high short-circuit current. Observe the following precautions when working on batteries:
  - Remove watches, rings, or other metal objects.
  - Use tools with insulated handles.
  - Wear insulating gloves and boots.
  - Do not lay tools or metal parts on top of batteries.

# Safety

-  **DANGER:** Risk of electric shock. Risk of fire. Do not work alone. Someone should be in the range of your voice or close enough to come to your aid when you work with or near electrical equipment.
-  **DANGER:** Risk of fire. Do not allow or place flammable, sparking, or explosive items near the IQ Battery(ies).
-  **DANGER:** Risk of electric shock. In areas where flooding is possible, install the IQ Battery(ies) at a height that prevents water ingress.
-  **DANGER:** Risk of electric shock. AC voltage is present at the output when the DC switch is on.
-  **DANGER:** Risk of electric shock. Branch circuit protection must be off before switching DC power on or off.
-  **DANGER:** Risk of electric shock. The DC switch must be in the OFF position for shipping and service.
-  **WARNING:** Risks of electric shock, energy hazard, and chemical hazard. Do not disassemble.
-  **WARNING:** Risk of equipment damage. During use, storage, transport, or installation, always keep the IQ Battery(ies) in an upright position.
-  **WARNING:** You must install the IQ Battery(ies) only on a suitable wall using an Enphase wall-mount bracket.
-  **WARNING:** Before installing or using the IQ Battery(ies), read all instructions and cautionary markings in this guide and on the equipment.
-  **WARNING:** Do not install or use the IQ Battery(ies) if it has been damaged in any way.
-  **WARNING:** Do not exceed the maximum number (1) of IQ Batteries in a 20 A AC branch circuit.
-  **WARNING:** Do not sit on, step on, place objects on, or insert objects into the IQ Battery(ies).
-  **WARNING:** Do not place beverages or liquid containers on top of the IQ Battery(ies). Do not expose the IQ Battery(ies) to liquids or flooding.
-  **WARNING:** When placing the IQ Battery(ies) in storage, ensure that AC power is not present and that the DC switch is in the OFF position. While in storage, damage to the battery can occur from over-discharge. If the battery state of charge falls to 0%, the IQ Battery(ies) can be damaged or destroyed. Because of this, the IQ Battery(ies) must only be stored for a limited amount of time.
  - The IQ Battery(ies) must be installed and energized by the “Must Energize By” date on the shipping box label.
  - The IQ Battery(ies) must have a state of charge of no more than 30% when placed in storage. To do this, the IQ Battery(ies) must be turned OFF at around 30% state of charge.
  - If the IQ Battery(ies) has already been installed, it must be turned OFF at around 30% state of charge prior to uninstalling. A battery can be stored for a maximum of two months if the last known State of Charge was 30%.

**Enphase Support:** <https://enphase.com/contact/support>

-  **NOTE:** Perform installation and wiring, including protection against lightning and resulting voltage surges, in accordance with all applicable local electrical codes and standards.
-  **NOTE:** Using unapproved attachments or accessories could result in damage or injury.
-  **NOTE:** Install properly rated overcurrent protection as part of the system installation.
-  **NOTE:** To ensure optimal reliability and to meet warranty requirements, the IQ Battery(ies) must be installed and/or stored according to the instructions in this guide.
-  **NOTE:** The Enphase IQ Battery(ies) are intended to operate with an internet connection. Failure to maintain an internet connection may have an impact on the warranty. See limited warranty for full terms and services ([enphase.com/warranty](https://enphase.com/warranty)).
-  **NOTE:** When replacing the Enphase IQ Battery(ies), you must replace it with an IQ Battery(ies) of the same type with the same AC current rating.
-  **NOTE:** When disconnected and stored, no automatic charge of the battery is possible.
-  **NOTE:** Properly mount the IQ Battery(ies). Ensure that the mounting location is structurally suited to bearing the weight of the IQ Battery(ies).
-  **NOTE:** During use, storage, and transport, keep the IQ Battery(ies):
  - Properly ventilated
  - Away from water, other liquids, heat, sparks, and direct sunlight
  - Away from excessive dust, corrosive and explosive gases like ammonia, and oil smoke
  - Away from direct exposure to gas exhaust, such as from motor vehicles
  - Free of vibrations
  - Away from falling or moving objects, including motor vehicles. If mounted in the path of a motor vehicle, we recommend a 91 cm (36 in) minimum mounting height
  - At an elevation of lower than 2,500 m (8,200 feet) above sea level
  - In a location compliant with fire safety regulations
  - In a location compliant with local building codes and standards
-  **NOTE:** Conditions for the IQ Battery 5P installation site also apply to storage conditions.
-  **NOTE:** Enphase Energy System requires a utility grid connection for commissioning and operation.
-  **NOTE:** All Enphase IQ Batteries are constructed with sealed lithium iron cells and utilize lithium iron phosphate (LiFePO4) chemistry. This chemistry does not produce flammable gases during normal charge and discharge operations. Therefore, no additional ventilation is required for indoor installations, in compliance with North American code requirements: NFPA 70, NFPA 855, International Residential Code, and International Fire Code.



## Environmental protection

**ELECTRONIC DEVICE: DO NOT THROW AWAY.** Waste electrical products should not be disposed of with household waste.

Proper disposal of batteries is required. Refer to your local codes for disposal requirements.

# Revision history

REVISION	DATE	DESCRIPTION
140-00279-10	March 2025	Added "IQ Battery 5P metering" section.
140-00279-09	October 2024	Updated voltage information.
140-00279-08	August 2024	Updated safety section based on UL recommendations.
140-00279-07	June 2024	Updated the "Choose a location for the IQ Battery array" and "Configure and activate" sections.
140-00279-06	March 2024	<ul style="list-style-type: none"><li>• Added IQ8D-BAT SKU code on page 2.</li><li>• Updated wiring cover screw torque instructions on pages 19 and 32.</li><li>• Updated wiring instructions mentioned on page 25.</li><li>• Updated NOTE in "Minimum clearances" section.</li></ul>
140-00279-05	January 2024	<ul style="list-style-type: none"><li>• Updated product images.</li><li>• Updated PCS disclaimer label.</li><li>• Updated Section C - wiring.</li><li>• Updated the torque value for the wiring cover screws.</li></ul>
140-00279-04	July 2023	General editorial updates. Updated control sequence diagrams and introduced drill template, PCS disclaimer, and Anchor Clip.
140-00279-03	May 2023	Added "Control (CTRL) Wiring between system components" section. Updated images (minimum clearance, mounting the bottom mounting bracket, and ID cover).

Previous releases.

# Installer notes

# Installer notes

IQ Battery-5P-QIG-140-00279-10-EN-US-2025-03-21

© 2025 Enphase Energy. All rights reserved. Enphase, the e and CC logos, IQ, and certain other marks listed at <https://enphase.com/trademark-usage-guidelines> are trademarks of Enphase Energy, Inc. in the U.S. and other countries. Data subject to change.

