

FENECON

FENECON Home 20 & 30 Assembly and Operating Instructions

Version:2025.11.01

Table of Contents

1. Information on these instructions	6
1.1. Manufacturer	6
1.2. Formal information on installation and service instructions	6
1.3. Version/revision	7
1.4. Symbol conventions	8
1.5. Structure of warning notices	8
1.6. Terms and abbreviations	9
1.7. Scope of delivery	10
1.8. Applicable documents	10
1.9. Availability	10
2. Safety	11
2.1. Intended use	11
2.2. Reasonably foreseeable misuse	11
2.3. Area of application — Electromagnetic compatibility (EMC)	12
2.4. Qualification of the staff	13
2.4.1. Trained electricians	13
2.4.2. Service staff	13
2.5. General information on the FENECON system	14
2.5.1. Environmental influences	14
2.5.2. Mechanical influences	15
2.5.3. Installation, operation and maintenance	15
2.5.4. Fire protection	16
2.5.5. Storage	17
2.5.6. Charging	17
2.6. Operating resources	18
2.6.1. Electrolyte solution of the battery modules	18
2.7. Residual risk	19
2.8. Behavior in emergency situations	19
2.9. Pictograms	20
2.10. Operating materials/equipment	22
2.10.1. Electrolyte solution of the battery modules	22
2.10.2. Electrical equipment	22
2.11. Personal protective equipment	24
2.12. Spare and wear parts	24
2.13. IT security	24

3. Technical data	25
3.1. General	25
3.2. Technical data — Inverter	26
3.2.1. Dimensions	27
3.3. Technical data — FENECON Home 20 & 30-EMS-Box	28
3.3.1. Dimensions	28
3.3.2. EMS box — Terminal assignment	29
3.4. Technical data — FENECON Home 20 & 30 Parallel box (optional)	30
3.4.1. Dimensions	30
3.4.2. Parallel box — Terminal assignment	31
3.5. Technical data — FENECON Home 20 & 30 extension box (optional)	32
3.5.1. Dimensions	32
3.5.2. Extension box — Terminal assignment	33
3.6. Technical data — FENECON Home 20 & 30-BMS-Box	34
3.6.1. Dimensions	34
3.7. Technical data — FENECON Home 20 & 30 battery module	35
3.7.1. Electrical parameters of the battery modules	36
3.8. Technical data — Base	38
3.8.1. Dimensions — Base	38
3.9. Technical data — Split base (optional)	39
3.9.1. Dimensions — Split base	39
3.10. Technical data — Top box (with option: split base)	40
3.10.1. Dimensions — Top box	40
4. General description	41
4.1. System configuration — General overview	41
4.2. System structure: Variants with emergency power	42
4.2.1. Standard setup with back-up power	42
4.2.2. System structure with additional PV producer	43
4.2.3. AC system diagram	44
4.2.4. System with manual emergency power changeover	45
4.2.5. Required components	46
5. Assembly preparation	47
5.1. Scope of delivery	47
5.1.1. FENECON Home 20 & 30 inverter	47
5.1.2. FENECON Home 20 & 30-EMS-Box	50
5.1.3. FENECON Home 20 & 30 Parallel box (optional)	52

5.1.4. FENECON Home 20 & 30 extension box (optional)	53
5.1.5. FENECON Home 20 & 30-BMS-Box/Base	54
5.1.6. BMS box/split base (optional)	55
5.1.7. FENECON Home 20 & 30 battery module	56
5.2. Tools required	57
6. Assembly	58
6.1. Assembly — Inverter	59
6.1.1. Safety instructions	59
6.1.2. Installation conditions and clearances at the installation site	63
6.1.3. Assembly	66
6.2. Assembly of battery tower 1 with FEMS box	67
6.2.1. Safety instructions	67
6.2.2. Conditions at the installation site	71
6.2.3. Installation conditions and clearances at the installation site	71
6.2.4. Assembly of battery tower 1 with FENECON Home 20 & 30 EMS box	73
6.3. Installation — Battery tower on split base	77
6.4. Electrical installation	82
6.4.1. Earthing the inverter and the battery tower	82
6.5. Approved network configurations for connecting the FENECON Home 20 & 30	82
6.5.1. Connection and wiring of the AC circuit	83
6.5.2. Synchronize to the grid	90
6.5.3. AC connection of the FENECON Home 20 & 30-EMS-Box	90
6.6. Explanation of the "zero feed-in" function	92
6.6.1. Configuration for zero feed-in via the FENECON Energy Management System	92
6.6.2. Notes on the zero feed-in function:	92
6.6.3. Validity of the declaration:	93
6.6.4. DC cable from the battery tower to the inverter	94
6.6.5. Connection and cabling of PV system	94
6.6.6. Connecting the smart meter to the inverter	95
6.6.7. Communication between inverter and EMS box	96
6.6.8. Communication from a battery tower	98
6.6.9. Communication with the customer network	98
6.6.10. Cover for the internal input (optional)	99
7. Parallel connection of several battery towers	100
7.1. Assembly of further battery towers	100
7.1.1. Assembly of battery tower 2 with FENECON Home 20 & 30 Parallel box	100

Table of Contents

7.1.2. Assembly of battery tower 3 to 4 with FENECON Home 20 & 30 extension box.	100
7.2. Electrical installation of additional battery towers.	101
7.2.1. DC cable between two battery towers and the Inverter	101
7.2.2. DC cable between the third to fourth battery tower and Parallel box	102
7.3. Communication of further battery towers	103
7.3.1. Communication between two to four battery towers	103
8. Initial commissioning	104
8.1. Checking the installation, connections and cabling.	104
8.2. Switching the system on/off	105
8.2.1. Switching on the system.	105
8.2.2. FEMS push-button and LED ring	106
8.2.3. Switching off.	106
8.3. Configuration via commissioning wizard.	108
9. FEMS Online Monitoring	113
9.1. Access data.	113
9.1.1. Access for the end customer	113
9.1.2. Access for the installer	113
10. Capacity expansion of the system	114
10.1. Capacity expansion of the battery tower by one or more battery modules	114
10.2. Capacity expansion of the system by one or more battery towers.	118
11. FEMS extensions	121
11.1. Connection of a heat pump via "SG-Ready"	123
11.2. Connection of a heating element with a maximum of 6 kW	124
11.3. Control of a heating element greater than 6 kW (control via external relay).	125
11.4. Controlling a CHP unit	126
11.5. Additional AC meter	127
11.6. Activation of the app in the FEMS App Center	129
12. Updating the FEMS	129
13. Starting point: FEMS App Center	131
13.1. Installation of further FEMS Apps.	132
13.1.1. Installation after redeeming a licence key.	132
13.1.2. Direct installation	134

14. External control of the inverter	139
14.1. Ripple control receiver at the AC output	139
14.2. Ripple control receiver on grid connection point.	143
14.3. Remote shutdown.	146
14.4. Section 14a of the Energy Industry Act (EnWG)	148
15. Troubleshooting	149
15.1. Errors in Online Monitoring.	149
15.1.1. Fault display	149
15.1.2. Troubleshooting	150
15.2. FENECON Home 20 & 30 inverter.	151
15.2.1. Fault display	151
15.2.2. Rotary field of the grid connection	152
15.3. Battery tower	153
15.3.1. Fault display	153
15.3.2. Troubleshooting	155
15.4. Fault list.	155
15.5. Service.	155
16. Technical maintenance	156
16.1. Tests and inspections	156
16.2. Cleaning	156
16.3. Maintenance work	156
16.4. Repairs	156
16.5. Warranty cases	157
17. Advice for fire departments when dealing with FENECON Home & Commercial systems	158
18. Flood safety measures FENECON Home & Commercial	159
19. Handover to the operator	161
19.1. Information for the operator.	161
20. Transport	162
21. Dismantling and disposal	163
21.1. Prerequisites	163
21.2. Dismantling	163
21.3. Disposal	164
22. Index	165

1. Information on these instructions

22.1. List of images	165
22.2. List of tables	167

1. Information on these instructions

Personnel must have carefully read and understood these installation and service instructions before starting any work.

1.1. Manufacturer

FENECON GmbH
Gewerbepark 6
94547 Iggensbach
Germany

Phone: +49 (0) 9903 6280 0

Fax: +49 (0) 9903 6280 909

E-mail: service@fenecon.de

Internet: www.fenecon.de

1.2. Formal information on installation and service instructions

© FENECON GmbH, 2026

All rights reserved.

Reprinting, even in part, is only permitted with the permission of FENECON GmbH.

1.3. Version/revision

Version/Revision	Change	Date	Name
2023.10.1	First draft	09/10/2023	FENECON TK
2023.11.1	Addition of sections 10-17	16/11/2023	FENECON TK
2023.12.1	Fault rectification	05/12/2023	FENECON TK
2024.01.1	Fault rectification/extension of section 11	10/01/2024	FENECON TK
2024.04.1	Fault rectification/extension of section 11.2	19/04/2024	FENECON TK
2024.07.1	Adaptation of section 10	15/07/2024	FENECON PM
2024.10.1	Adaptation section 11	02/10/2024	FENECON MR
2024.11.1	Adaptation of section 9	05/11/2024	FENECON MR
2025.1.1	Integration of fire department notice	27/01/2025	FENECON MR
2025.8.1	Integration split base	01/08/2025	FENECON TK/MR
2025.11.1	Integration flood warning	03/11/2025	FENECON PM

Table 1. Version/revision

1.4. Symbol conventions

1.4. Symbol conventions





	<p>This symbol indicates an imminent danger. If this danger is not avoided, it can lead to death or serious injury.</p>
	<p>This symbol indicates a potentially dangerous situation. If this dangerous situation is not avoided, it may result in minor or moderate injury.</p>
	<p>This symbol indicates a warning. Failure to observe this warning may result in damage and/or destruction of the system.</p>
	<p>This symbol indicates a note. It is recommended that the note be observed.</p>

Table 2. Symbol conventions

1.5. Structure of warning notices

Warning notices protect against possible personal injury and damage to property if observed and classify the magnitude of the danger by means of the signal word.



Source of the danger

Possible consequences of non-compliance

- Measures for avoidance/prohibitions

Danger sign

The danger sign indicates warnings that warn of personal injury.

Source of danger

The source of danger indicates the cause of the hazard.

Possible consequences of non-compliance

The possible consequences of ignoring the warning are e. g. crushing, burns or other serious injuries.

Measures/prohibitions

Measures/prohibitions include actions that must be taken to avoid a hazard (e. g. stop the drive) or that are prohibited to avoid a hazard.

1.6. Terms and abbreviations

The following terms and abbreviations are used in the installation and service instructions:

Term/abbreviation	Meaning
AC	Alternating Current
CHP	Combined heat and power plant (CHP)
BMS	Battery Management System
DC	Direct Current
EMS	Energy Management System
Energy meter	Electricity meter for the inverter at the grid connection point
FEMS	FENECON Energy Management System
Commissioning	Commissioning
MPPT	Maximum Power Point Tracking Finder for the maximum power point
GCP	grid connection point
PE	Protective conductor
PV	Photovoltaics
RTE	Round-Trip-Efficiency (RTE) System efficiency — ratio of discharged to charged energy quantity
SG-Ready	Smart-Grid-Ready — Preparation of the heat pump for external control
SoC	State of Charge State of charge The available capacity in a battery, expressed as a percentage of the nominal capacity.
SoH	State of Health — State of ageing
VDE	German Association for Electrical, Electronic & Information Technologies e. V.
Widget	Component of Online Monitoring

Table 3. Terms and abbreviations

1.7. Scope of delivery

1.7. Scope of delivery

Item	Component	Number	Comment
1	FENECON Home 20 & 30-Inverter	1	Depending on version, 20 or 30 kW
2	FENECON Home 20 & 30-EMS Box (incl. FENECON Energy Management System)	1	
3	FENECON Home 20 & 30-Parallel Box	1	optional for 2nd FENECON Home 20 & 30 battery tower
4	FENECON Home 20 & 30-Extension Box	1	optional for 3rd & 4th FENECON Home 20 & 30 battery tower
5	FENECON Home 20 & 30-BMS Box	1	each FENECON Home 20 & 30-Battery Tower
6	FENECON Home 20 & 30-Battery module		depending on the capacity ordered
7	FENECON Home 20 & 30-Base	1	per FENECON Home 20 & 30-battery tower

Table 4. Scope of delivery

Component	Comment
Operating instructions FENECON Home 20 & 30	Instructions for the installer
Quick start guide FENECON Home 20 & 30	Quick start guide for the installer
Operating instructions FENECON Home 20 & 30	Instructions for the user/end customer
Brochure FENECON Home 20 & 30	

Table 5. Documents

1.8. Applicable documents

All documents listed in the appendix to these installation and service instructions must be observed.
See 15.1 Applicable documents

1.9. Availability

The operator must keep these installation and service instructions or relevant parts of them within easy reach in the immediate vicinity of the product.

If the product is handed over to another person, the operator passes these installation and service instructions on to that person.

2. Safety

2.1. Intended use

The FENECON electrical energy storage system is used to store electrical energy in rechargeable lithium iron phosphate battery modules (charging) and to provide electrical energy (discharging). This charging and discharging process takes place via a connected inverter. The system must only be used in compliance with the permissible technical data (see section [Technical data](#)).

FENECON power storage systems consist of various modules. In particular, these include a BMS (battery management system), the FENECON Energy Management System (FEMS), battery modules and bases. All processes of the electricity storage system are monitored and controlled by the FEMS.

Any other use is not an intended use.

2.2. Reasonably foreseeable misuse

All applications that do not fall within the scope of the intended use are considered misuse.

Work on live parts is generally not permitted. Electrical work must only be carried out by qualified electricians.

The following safety rules must be observed for all work on electrical components:

1. Disconnect.
2. Secure against restarting.
3. Check that there is no voltage.
4. Earth and short-circuit.
5. Cover or shield neighboring live parts.



Non-compliance with the safety rules is considered a reasonably foreseeable misuse.

Other misuses include in particular:

- improper transportation, installation or assembly at a location, trial operation or operation that could damage the system.
- change in the specified technical characteristics, including the individual components.
- change or deviation of the connected load.
- functional or structural changes.
- operating the product in a faulty or defective condition.

2.3. Area of application — Electromagnetic compatibility (EMC)

- improper repairs.
- operation without protective devices or with defective protective devices.
- disregarding the information in the original installation and service instructions.
- unauthorized access via the control unit or the network.
- the installation of firmware updates that were not obtained via FENECON.
- fire, open light and smoking in the vicinity of the storage system.
- insufficient ventilation at the installation site.
- unauthorized changes and actions to the electrical energy storage system.
- use as mobile energy storage.
- direct use in a PV system (integration via an AC-coupled grid is possible).

2.3. Area of application — Electromagnetic compatibility (EMC)

The low-voltage equipment is intended for use in the following areas of application:

- General public (public)

Use in other areas of application is not in accordance with the intended use.

2.4. Qualification of the staff

Qualified personnel must be deployed for the intended use, installation and maintenance of the system. The area of responsibility, competence and supervision of the personnel must be precisely regulated by the operator.

2.4.1. Trained electricians

Trained electricians include persons who:

1. are able to carry out work on electrical systems due to their technical training, knowledge and experience as well as knowledge of the relevant standards and regulations.
2. have been commissioned and trained by the operator to carry out work on electrical systems and equipment of the battery system.
3. are familiar with how the battery system works.
4. recognize hazards and prevent them by taking appropriate protective measures.

2.4.2. Service staff

Service personnel includes the manufacturer's personnel or specialist personnel instructed and authorized by FENECON GmbH, who must be requested by the operator to work on the system (e. g. assembly, repair, maintenance, work on the batteries, etc.).

2.5. General information on the FENECON system

2.5. General information on the FENECON system

The product must be positioned in such a way that sufficient room for movement can be guaranteed for service and maintenance personnel in every phase of the product's life. The service life of the product depends on the service life and maintenance intervals carried out by qualified personnel. The service life is particularly influenced by preventive maintenance and servicing.

- The battery modules must only be installed and the cable connections made by trained electricians.
- The electrical energy storage system must only be used under the specified charging/discharging conditions (see section [Technical data](#)).
- Keep the electrical energy storage system away from children and animals.
- Do not connect the plug contacts of the BMS box in reverse.
- Do not short-circuit battery modules.
- Only use the battery modules as intended.

Improper use can lead to overheating, explosion or fire of the battery modules.

- Read the instructions for installation and operation to avoid damage due to incorrect operation.
- The battery modules may have insufficient cell voltage after a long storage period. If this is the case, please contact the service department
- Do not expose the battery modules to high voltages.
- Place the battery modules on level surfaces.
- Do not place any objects on the FENECON battery towers.

2.5.1. Environmental influences

- Keep the electrical energy storage system away from water sources.
- Do not immerse the electrical energy storage system in water, moisten it or touch it with wet hands.
- Set up/store the electrical energy storage system in a cool place.
- Do not heat the electrical energy storage system.
- Do not expose the electrical energy storage system to open fire.
- Do not set up or use the electrical energy storage system near open fires, heaters or high-temperature sources.

The heat can cause insulation to melt and the safety ventilation to be damaged. This can lead to overheating, explosion or fire on the battery modules.

- No soldering work must be carried out on the electrical energy storage system. Heat introduced

during soldering can damage the insulator and the safety venting mechanism and lead to overheating, explosion or fire of the battery modules.

2.5.2. Mechanical influences

- The battery modules must not be dismantled or modified. The battery modules contain a safety mechanism and a protective device, damage to which can lead to overheating, explosion or fire of the battery modules.
- Do not step on the electrical energy storage system.
- Do not attempt to crush or open battery modules.
- Do not apply any mechanical force to the electrical energy storage system.

The battery modules can be damaged and short circuits can occur, which can lead to overheating, explosion or fire of the battery modules.

- Do not throw or drop parts of the power storage system.

Do not use defective or dropped battery modules.

- Do not use the electrical energy storage system if changes in color or mechanical damage are detected during assembly, charging, normal operation and/or storage.
- If the protective devices are damaged, abnormal charging currents and voltages can cause a chemical reaction in the battery modules, which can lead to overheating, explosion or even fire in the battery modules.

2.5.3. Installation, operation and maintenance



When carrying out maintenance, servicing and cleaning work, ensure that the product is switched off in a safe manner and secured against being switched on again. In addition, all instructions in these installation and service instructions must be followed.

Always observe the following safety instructions when installing, operating or maintaining the battery modules:

- Installation/maintenance work and making cable connections must only be carried out by qualified personnel (trained electricians).
- During maintenance work, stand on dry insulating objects and do not wear any metal objects (e.g. watches, rings and necklaces) during maintenance work/operation.
- Use insulated tools and wear personal protective equipment.
- Do not touch two charged contacts with a potential difference.
- Measure the battery voltage with a multimeter and ensure that the output voltage is 0 V in off

2.5. General information on the FENECON system

mode.

- If an anomaly is detected, switch off the battery tower immediately.
- Only continue the maintenance work after the causes of the anomaly have been eliminated.
- The battery modules can cause electric shock and burns due to high short-circuit currents.
- Do not touch the battery module connectors (+) and (-) directly with a wire or metal object (e. g. metal chain, hairpin). Excessive current can be generated in the event of a short circuit, which can lead to overheating, explosion or fire of the battery modules.

2.5.4. Fire protection

- Do not expose the electrical energy storage system to direct sunlight.
- Avoid contact with conductive objects (e. g. wires).
- Keep heat and fire sources, flammable, explosive and chemical materials away from the electrical energy storage system.
- Explosion hazard: Do not dispose of battery modules in a fire!

2.5.5. Storage

- Area: Fireproof indoors/outdoors with suitable weather protection.
- Air temperature: -20 °C to 40 °C.
- Relative humidity: max. 50 % at +40 °C.
- Do not store battery modules (lithium iron phosphate batteries) with flammable or toxic objects.
- Store battery modules with safety defects separately from undamaged battery modules.

Storage longer than 12 months

Possible consequences: Deep discharge of the cells/defective battery.



- External charging of the battery modules to nominal voltage — forced charging must be carried out, which is controlled via the FEMS. This must only be carried out by the manufacturer or by a company commissioned by the manufacturer.

2.5.6. Charging

- Keep the SoC of the battery module below 30% for shipping and charge the battery module if it has been stored for more than 12 months.

2.6. Operating resources

2.6. Operating resources

2.6.1. Electrolyte solution of the battery modules

- Electrolyte solution is used in the battery modules (lithium iron phosphate).
- The electrolyte solution in the battery modules is a clear liquid and has a characteristic odor of organic solvents.
- The electrolyte solution is flammable.
- The electrolyte solution in the battery modules is corrosive.
- Do not inhale the vapors.
- If the electrolyte solution is swallowed, induce vomiting.
- Leave the contaminated area immediately after inhaling the vapors.
- Eye and skin contact with leaked electrolyte solution must be avoided.
- Contact with electrolyte solution can cause severe burns to the skin and damage to the eyes.

After skin contact: Immediately wash skin thoroughly with neutralizing soap and consult a doctor if skin irritation persists.

After eye contact: Immediately flush eye(s) with running water for 15 minutes and seek medical advice.



Delayed treatment can cause serious damage to health.

2.7. Residual risk



Warning of electrical voltage

Work on electrical equipment may only be carried out by qualified electricians from the manufacturer or by specially authorized, trained electricians and in compliance with the safety regulations.

Maintenance work must not be carried out for 5 minutes after the power supply has been disconnected.

The customer must provide a mains disconnection device for the electrical power supply.



Unknown fault messages

Unknown faults and attempts to rectify them can lead to damage to the product. If there is a fault that is not included in the fault list, inform customer service.



All doors, emergency exits and areas around the electrical energy storage system must remain clear; do not obstruct escape routes!



The condition of the floor outside the storage system is the responsibility of the user. However, the housing is sealed so that no electrolyte can escape.

2.8. Behavior in emergency situations

Proceed as follows in emergency situations:

1. Disconnect the electrical energy storage system from the grid.
2. Leave the zone of danger immediately.
3. Secure the area.
4. Inform those responsible.
5. Call a doctor if necessary.

2.9. Pictograms

2.9. Pictograms

Pictograms on the system indicate dangers, prohibitions and instructions. Illegible or missing pictograms must be replaced by new ones.

Pictogram	Meaning	Description
	Warning of dangerous electrical voltage	Pictogram on the enclosure, and marking of components which do not clearly indicate that they contain electrical equipment which may be the cause of a risk of electric shock.
	General warning sign	
	Battery charging hazard warning	Pictogram on enclosure and marking of components not clearly identified as containing electrical equipment that may give rise to a battery charging hazard.
	No naked flames; fire, naked source of ignition and smoking prohibited	Pictogram on the enclosure and marking of components that do not clearly indicate that they contain electrical equipment that may present a risk of naked flames, fire, naked sources of ignition and smoking.
	Protective earthing symbol	
	Separate collection of electrical and electronic equipment	
	Note instructions	
	Use protective headgear	
	Use protective footwear	




Pictogram	Meaning	Description
	Use protective gloves	
	CE mark	
	Product is recyclable.	

Table 6. Pictograms

2.10. Operating materials/equipment

2.10. Operating materials/equipment

2.10.1. Electrolyte solution of the battery modules

- Electrolyte solution is used in the battery modules (lithium iron phosphate).
- The electrolyte solution in the battery modules is a clear liquid and has a characteristic odor of organic solvents.
- The electrolyte solution is flammable.
- The electrolyte solution in the battery modules is corrosive.
- Contact with electrolyte solution can cause severe burns to the skin and damage to the eyes.
- Do not inhale the vapors.
- If the electrolyte solution is swallowed, induce vomiting.
- Leave the contaminated area immediately after inhaling the vapors.
- Eye and skin contact with leaked electrolyte solution must be avoided.

After skin contact: Immediately wash skin thoroughly with neutralizing soap and consult a doctor if skin irritation persists.

After eye contact: Immediately flush eye(s) with running water for 15 minutes and seek medical advice.

Delayed treatment can cause serious damage to health.

2.10.2. Electrical equipment

- Work on electrical equipment must only be carried out by qualified electricians.
- The five safety rules must be observed for all work on electrical components:
 1. Disconnect.
 2. Secure against restarting.
 3. Check that there is no voltage.
 4. Earth and short-circuit.
 5. Cover or shield neighboring live parts.
- Maintenance work must only be carried out by trained specialist personnel (service personnel).
- Before starting work, carry out visual checks for insulation and housing damage.
- The system must never be operated with faulty or non-operational electrical connections.
- To avoid damage, lay supply lines without crushing and shearing points.
- Only insulated tools must be used for maintenance on uninsulated conductors and terminals.

- Control cabinets (e. g. inverter housing) must always be kept locked. Only authorized personnel with appropriate training and safety instructions (e. g. service personnel) should be allowed access.
- The inspection and maintenance intervals for electrical components specified by the manufacturer must be observed.
- To avoid damage, lay supply lines without crushing and shearing points
- If the power supply is disconnected, specially marked external circuits may still be live!
- Some equipment (e. g. inverters) with an electrical intermediate circuit may still carry dangerous residual voltages for a certain period of time after disconnection. Before starting work on these systems, check that they are de-energized.

2.11. Personal protective equipment

2.11. Personal protective equipment

Depending on the work on the system, personal protective equipment must be worn:

- Protective footwear
- Protective gloves, cut-resistant if necessary
- Protective eyewear
- Protective headgear

2.12. Spare and wear parts

The use of spare and wear parts from third-party manufacturers can lead to risks. Only original parts or spare and wear parts approved by the manufacturer must be used. The instructions for spare parts must be observed. Further information can be found in the wiring diagram.



Further information must be requested from the manufacturer.

2.13. IT security

FENECON systems and their applications communicate and operate without an internet connection. The individual system components (inverters, batteries, etc.) are not directly connected to the internet or accessible from the Internet. Sensitive communications via the internet are processed exclusively via certificate-based TLS encryption.

Access to the programming levels is not barrier-free and is accessible at different levels depending on the qualifications of the operating personnel. Safety-relevant program changes require additional verification.

FENECON processes energy data of European customers exclusively on servers in Germany and these are subject to the data protection regulations applicable in this country.

The software used is checked using automated tools and processes established during development in order to keep it up to date and to rectify security-relevant vulnerabilities at short notice. Updates for FEMS are provided free of charge for life.

3. Technical data

3.1. General

designation		value/size
Installation/environmental conditions	IP classification	IP55
	Operating altitude above sea level	≤ 2,000 m
	Installation/operating temperature	-30 °C to +60 °C
	Relative humidity (operation/storage)	50 % non-condensing (up to 90 % permissible for short periods)
	Battery operating temperature	-10 °C to +50 °C
	Optimal operating temperature of the battery	15 °C to +30 °C
	Cooling	adaptive fan
	Loudness	< 45 dB
	Max. Grid connection	120 A
Certification/guideline	Overall system	CE
	Inverter	VDE 4105:2018-11 Gate generator type A 1.1
	Battery	UN38.3 VDE 2510-50

Table 7. Technical data — General

3.2. Technical data — Inverter

3.2. Technical data — Inverter

Description		Value/dimension	
		FHI-20-DAH	FHI-30-DAH
Inverter model		FHI-20-DAH	FHI-30-DAH
DC PV connection	Max. DC input power	30 kW _p	45 kW _p
	MPP tracker	2	3
	Number of inputs per MPPT	2 (MC4)	2 (MC4)
	Starting voltage	200 V	200 V
	Max. DC operating voltage in V	950 V	950 V
	Max. DC input voltage in V	1000 V	1000 V
	MPPT voltage range	200 V to 850 V	200 V to 850 V
	Nominal input voltage in V	620 V	620 V
	Max. Input current per MPPT	30 A	30 A
	Max. short-circuit current per MPPT	38 A	38 A
AC connection	Grid connection	400/380 V, 3L/N/PE, 50/60 Hz	400/380 V, 3L/N/PE, 50/60 Hz
	Max. output current	29 A	43.3 A
	Max. input current	45 A	50 A
	Nominal apparent power output	20,000 VA	29,900 VA
	Max. apparent power output	22,000 VA	29,900 VA
	Max. apparent power from the grid	30,000 VA	33,000 VA
	Cos(φ)	-0.8 to +0.8	-0.8 to +0.8
Emergency power	Emergency power capable	Yes	Yes
	Network configuration	400/380 V, 3L/N/PE, 50/60 Hz	400/380 V, 3L/N/PE, 50/60 Hz
	Emergency power supplied with emergency power (per phase)	20.000 VA (6,666 VA)*	29,900 VA (9,966 VA)*
	Unbalanced load	6,666 VA	9,999 VA
	Black start	Yes	Yes
	Solar recharging	Yes	Yes
Efficiency	Max. Efficiency	98.0 %	98.0 %
	European efficiency	97.5 %	97.5 %
General	Width Depth Height	520 220 660 mm	520 220 660 mm
	Weight	48 kg	54 kg
	Topology	not insulated	not insulated

Table 8. Technical data — Inverter

*also in parallel mains operation

3.2.1. Dimensions

The dimensions are given in mm.

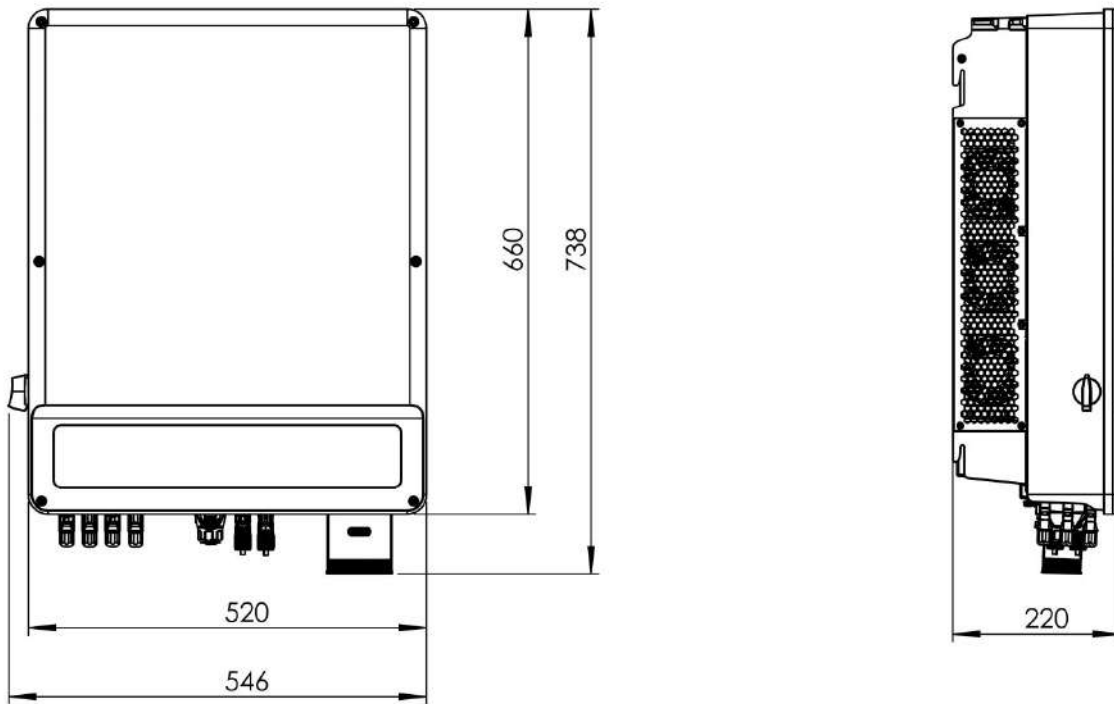


Illustration 1. Inverter — Dimensions

3.3. Technical data — FENECON Home 20 & 30-EMS-Box

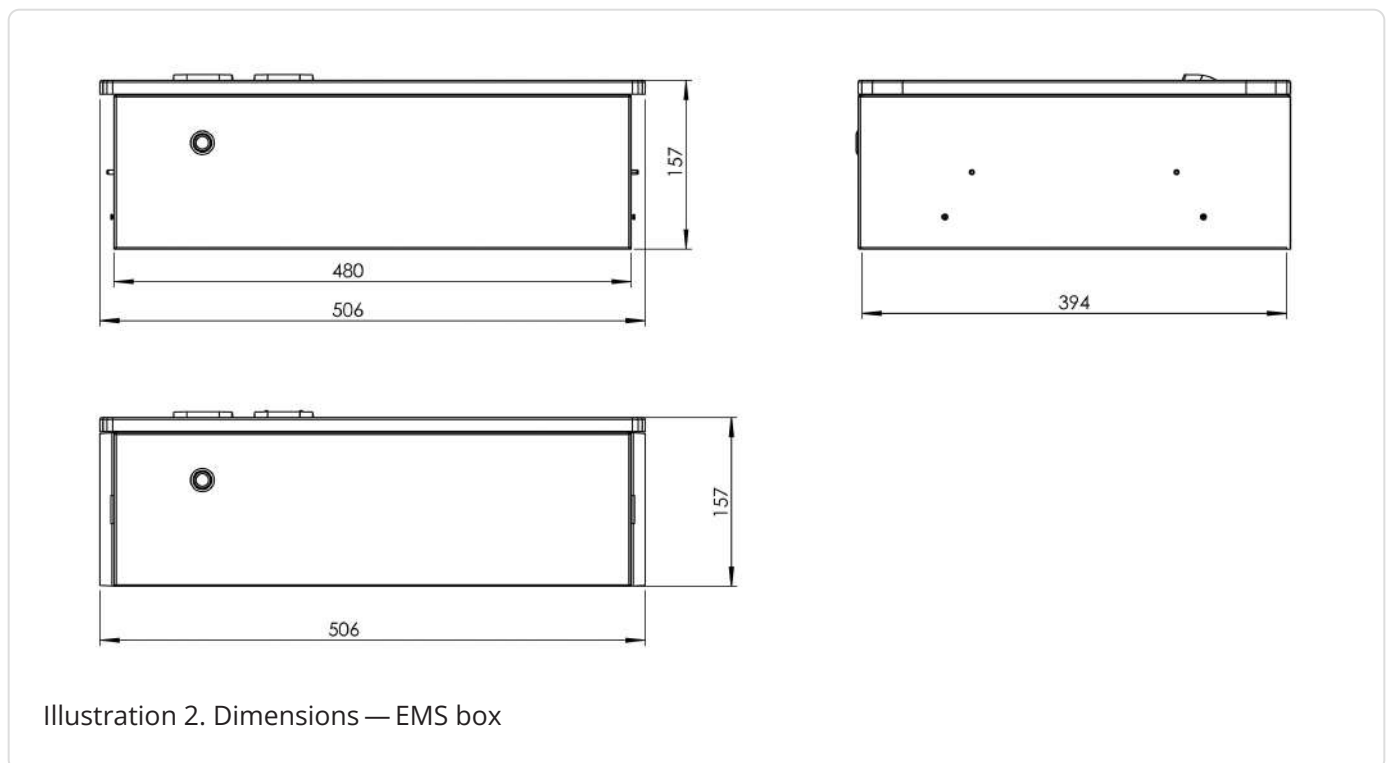
3.3. Technical data — FENECON Home 20 & 30-EMS-Box

Naming	Value/Size
Operating voltage DC	224 V to 672 V
Max. Current (battery)	50 A
Operating temperature	-10 °C to 50 °C
Protection class	IP55 (plugged in)
Input voltage	100 V to 240 V/1.8 A/50 Hz to 60 Hz
width depth height	506 401 157 mm
Weight	12 kg
installation	stackable

Table 9. Technical data — FENECON Home 20 & 30-EMS-Box

3.3.1. Dimensions

The dimensions are given in mm.



3.3.2. EMS box — Terminal assignment

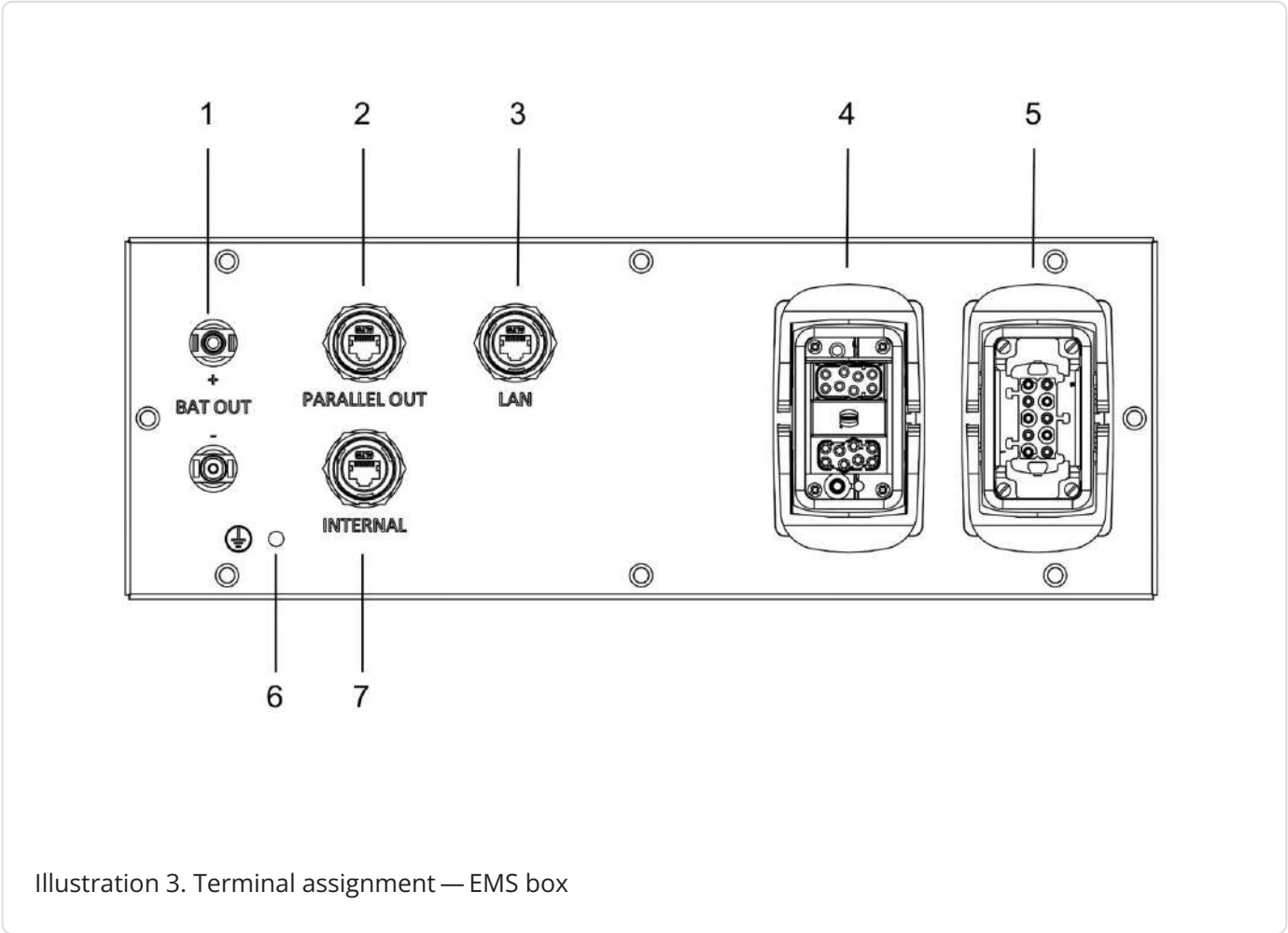


Illustration 3. Terminal assignment — EMS box

Item	Description
1	Battery connection to the Inverter (MC4-Evo stor)
2	Communication output for parallel connection of several batteries
3	Customer network connection (LAN) RJ45 (network cable not included)
4	Communication Inverter, relay outputs; digital inputs (16-pin connector)
5	Power supply FEMS box; potential-free contacts (max. 10 A, measured) (10-pin plug)
6	Earth connection
7	For future applications (not assigned)

Table 10. Terminal assignment — EMS box

3.4. Technical data — FENECON Home 20 & 30 Parallel box (optional)

3.4. Technical data — FENECON Home 20 & 30 Parallel box (optional)

Naming	Value/Size
Operating voltage DC	224 V to 672 V
Max. Current (battery)	50 A
Operating temperature	-10 °C ~ 50 °C
Protection class	IP55 (plugged in)
Width Depth Height	506 401 157 mm
Weight	10 kg
installation	stackable

Table 11. Technical data — Parallel box

3.4.1. Dimensions

The dimensions are given in mm.

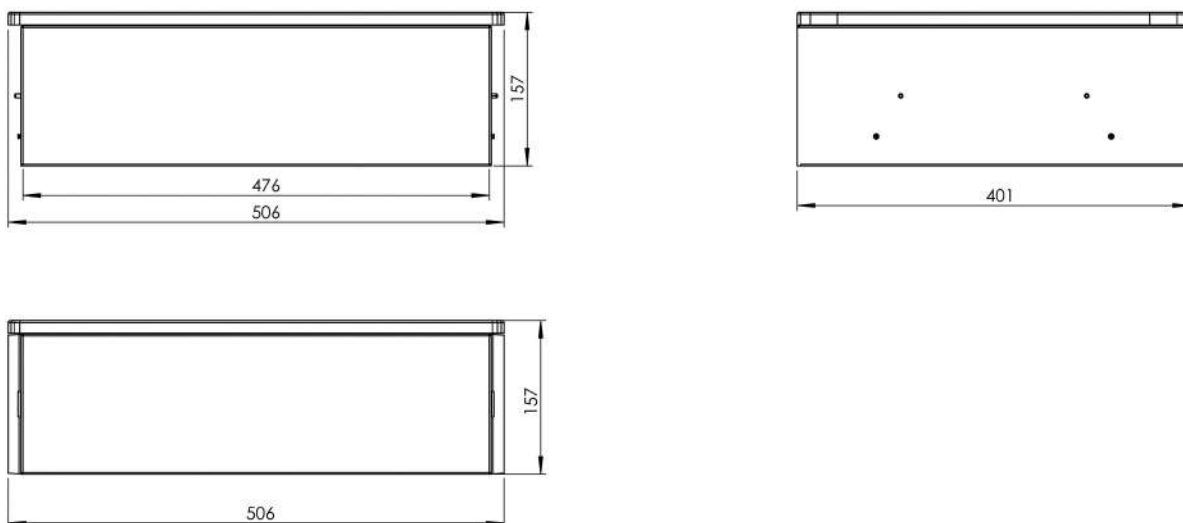


Illustration 4. Dimensions — Parallel box

3.4.2. Parallel box — Terminal assignment

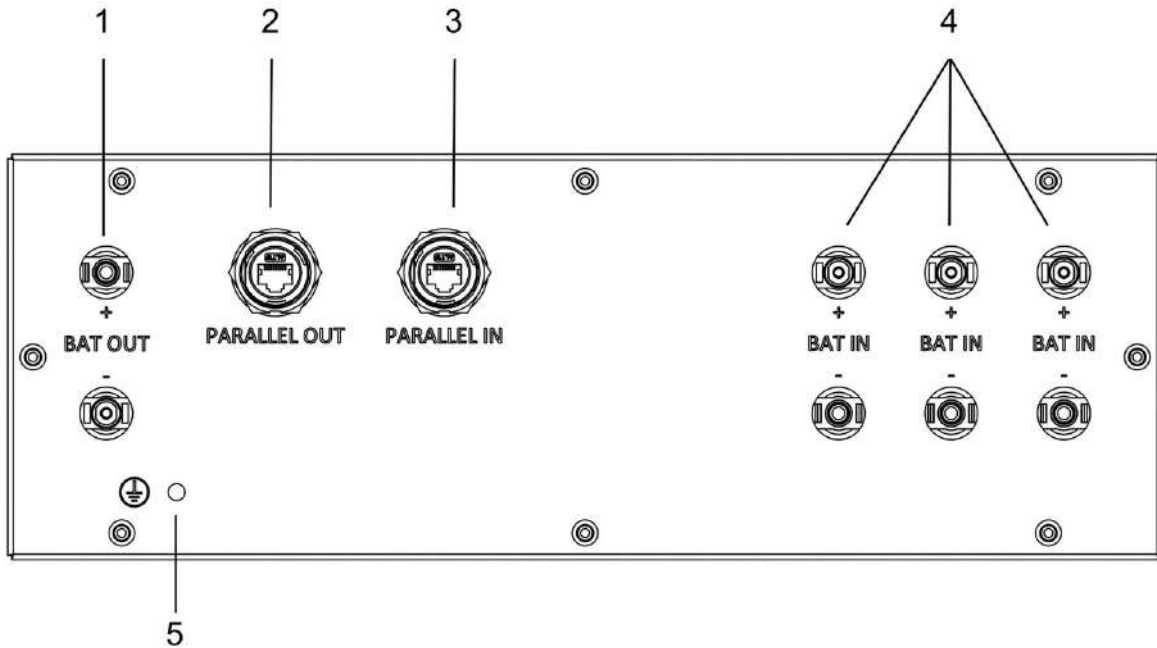


Illustration 5. Terminal assignment — Parallel box

Item	Description
1	Battery connection to the Inverter (MC4-Evo stor)
2	Communication output for parallel connection of several battery towers
3	Communication input for parallel connection of several battery towers
4	Battery connection for additional battery towers (MC4-Evo-stor)
5	Earthing connection

Table 12. Terminal assignment — Parallel box

3.5. Technical data — FENECON Home 20 & 30 extension box (optional)

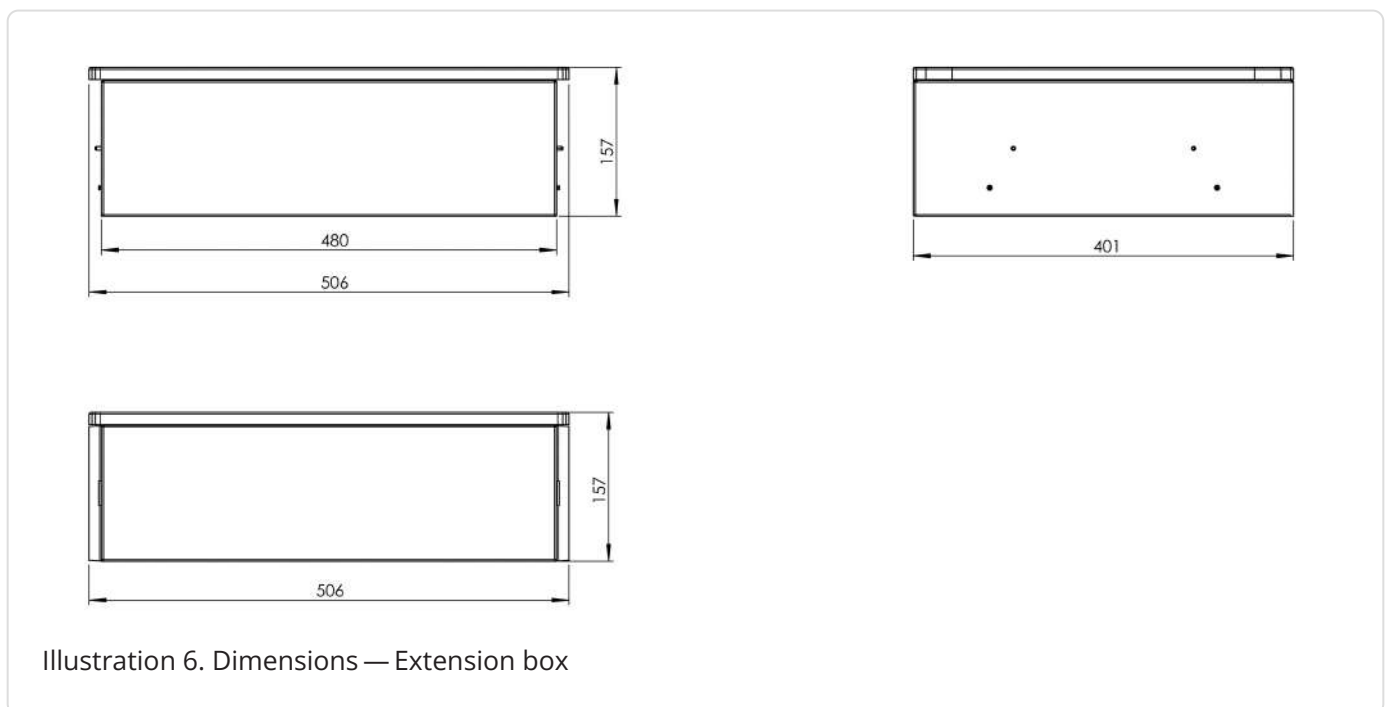
3.5. Technical data — FENECON Home 20 & 30 extension box (optional)

Naming	Value/Size
Operating voltage DC	224 V to 672 V
Max. Current (battery)	50 A
Operating temperature	-10 °C ~ 50 °C
Protection class	IP55 (plugged in)
Width Depth Height	506 401 157 mm
Weight	9 kg
installation	stackable

Table 13. Extension box (optional)— Technical data

3.5.1. Dimensions

The dimensions are given in mm.



3.5.2. Extension box — Terminal assignment

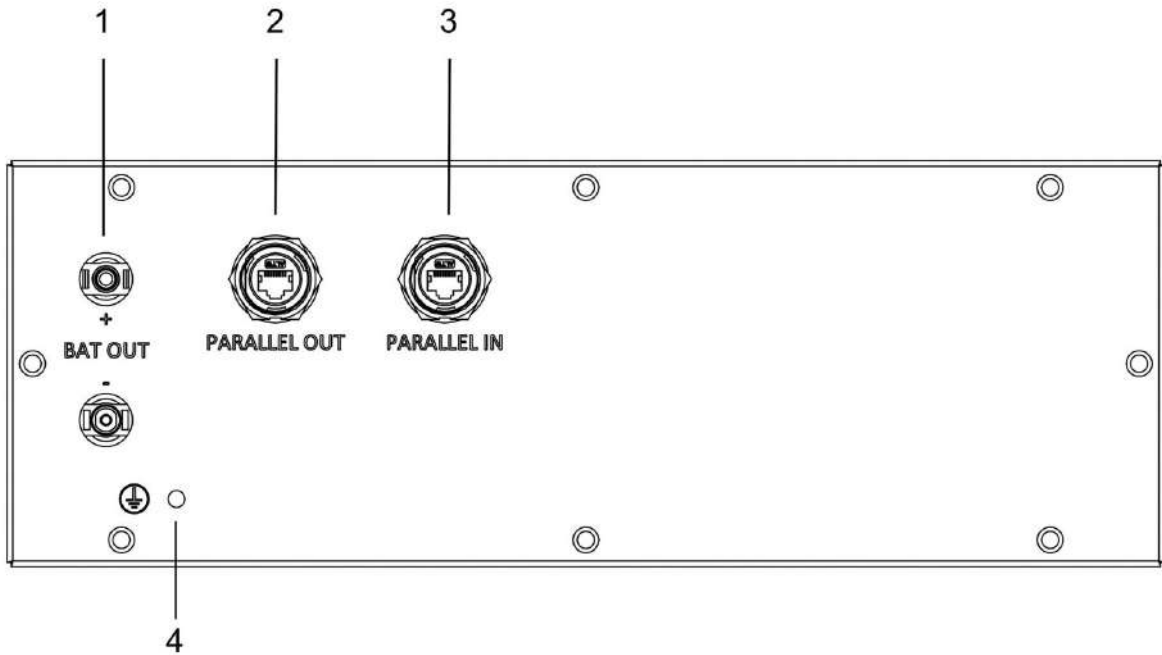


Illustration 7. Terminal assignment — Extension box

Item	Description
1	Battery connection to EMS box in parallel (MC4-Evo stor)
2	Communication output for parallel connection of several battery towers
3	Communication input for parallel connection of several battery towers
4	Earthing connection

Table 14. Terminal assignment — Extension box

3.6. Technical data — FENECON Home 20 & 30-BMS-Box

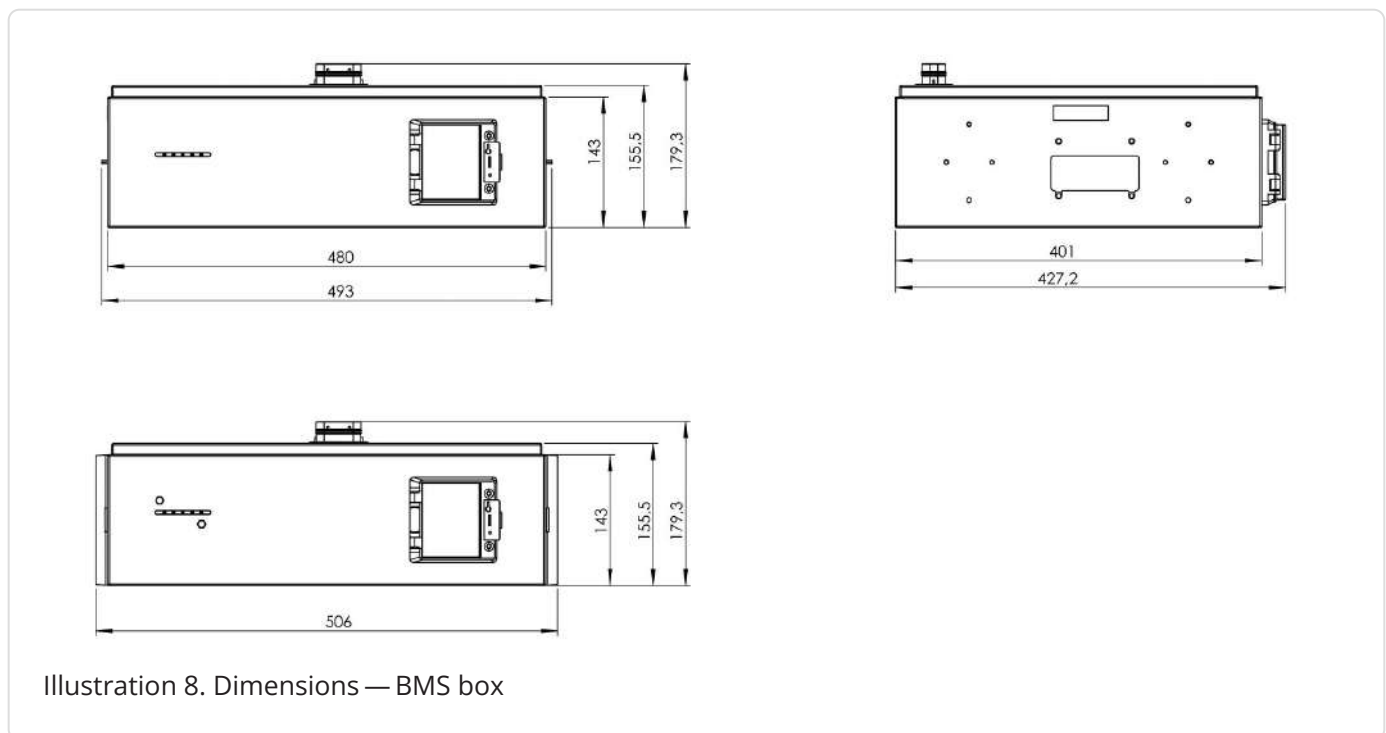
3.6. Technical data — FENECON Home 20 & 30-BMS-Box

Description	Value/Size
Maximum operating voltage range	224 V to 672 V
Maximum output/input current	50 A
Optimum operating temperature	15 to 30 °C
Operating temperature range	-20 to 55 °C
Protection class	IP55 (plugged in)
Width (incl. side panel) Depth Height	506 401 143 mm
Weight	13 kg
Installation	stackable/wall mounting

Table 15. Technical data — BMS box

3.6.1. Dimensions

The dimensions are given in mm.



3.7. Technical data — FENECON Home 20 & 30 battery module

Naming	Value/Size
Usable capacity	62.4 Ah/2.80 kWh
Rated voltage	44.8 V
Output voltage range	39.2 V to 50.4 V
Battery operating temperature range	-20 °C to +55 °C
Storage temperature range (over 7 days)	-30 °C to +60 °C
Storage temperature range (over 30 days)	-20 °C to +55 °C
Storage temperature range (cumulative up to 270 days)	-10 °C to +45 °C
Protection class	IP55 (plugged in)
Weight	30 kg
Installation	Stackable
Parallel connection	4 battery towers in parallel
Cooling	natural cooling
Shipping capacity	< 30 % SOC
Module safety certification	VDE 2510/IEC62619
UN transportation test standard	UN38.3
Relative humidity during storage	5 % to 95 %

Table 16. Technical data — Battery module



Storage longer than 12 months

Possible consequences: Deep discharge of the cells Defect of the battery module.
 - External charging of the battery modules to nominal voltage. This must only be carried out by the manufacturer or a company commissioned by the manufacturer.

3.7. Technical data — FENECON Home 20 & 30 battery module

3.7.1. Electrical parameters of the battery modules

For battery modules 5 to 7

Parameter	Value/size		
	5S	6S	7S
Number of modules	5S	6S	7S
Nominal capacity	14.0 kWh	16.8 kWh	19.6 kWh
Width incl. side panel	506 mm		
Depth	401 mm		
Height	1120 mm	1263 mm	1406 mm
Weight	187 kg	217 kg	247 kg
Nominal voltage	224.0 V	268.8 V	313,6 V
Output voltage range	196 V ~ 252 V	235.2 V ~ 302.4 V	274.4 V ~ 352.8 V
Maximum continuous charging/discharging power	11.20 kW	13.44 kW	15.68 kW

Table 17. Electrical parameters — Number of battery modules 4S to 6S (5 to 7 modules in series)

For battery modules 8 to 11

Parameter	Value/Size			
	8S	9S	10S	11S
Module	8S	9S	10S	11S
Nominal capacity	22.4 kWh	25.2 kWh	28.0 kWh	30.8 kWh
Width incl. side panel	506 mm			
Depth	401 mm			
Height	1549 mm	1692 mm	1835 mm	1978 mm
Weight	277 kg	307 kg	3370 kg	367 kg
Rated voltage	358.4 V	403.2 V	448.0 V	492.8 V
Output voltage range	313.6 V ~ 403.2 V	352.8 V ~ 453.6 V	392.0 V ~ 504.0 V	431.2 V ~ 554.4 V
Maximum continuous charging/discharging power	17.92 kW	20.16 kW	22.40 kW	24.64 kW

Table 18. Electrical parameters — Number of battery modules 7S to 10S (8 to 11 modules in series)

For battery modules 12 to 15

Parameter	Value/Size			
	12S	13S	14S	15S
Module	12S	13S	14S	15S
Nominal capacity	33.6 kWh	36.4 kWh	39.2 kWh	42.0 kWh
Width incl. side panel	506 mm			
Depth	401 mm			
Height	2121 mm	2264 mm	2407 mm	2550 mm
Weight	397 kg	427 kg	457 kg	487 kg
Rated voltage	537.6 V	582.4 V	627.2 V	672.0 V
Output voltage range	470.4 V ~ 604.8 V	509.6 V ~ 655.2 V	548.8 V ~ 705.6 V	588.0 V ~ 756.0 V
Maximum continuous charging/discharging power	26.88 kW	29.12 kW	30.00 kW	30.00 kW

Table 19. Electrical parameters — Amount of battery modules 7S to 10S (12 to 15 modules in series)

3.8. Technical data — Base

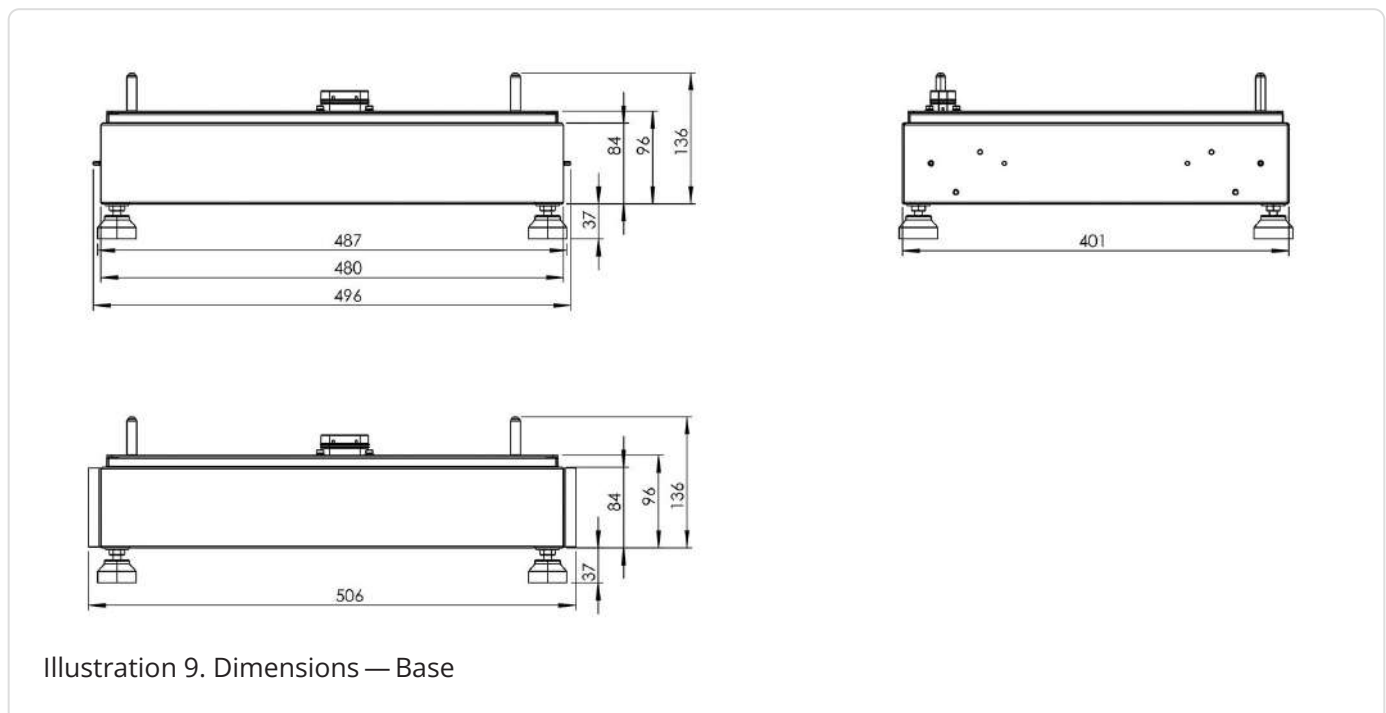
3.8. Technical data — Base

Designation	Value/dimension
Width (incl. side panel) Depth Height	506 401 84 mm
Weight	6 kg
Protection specification	IP55 (plugged in)
Installation	stackable

Table 20. Technical data — Base

3.8.1. Dimensions — Base

The dimensions are given in mm.



3.9. Technical data — Split base (optional)

Designation	Value/dimension
Width (incl. side panel) Depth Height	1312 401 84 mm
Weight	11 kg
Protection specification	IP55 (plugged in)
Installation	stackable

Table 21. Technical data — Split base

3.9.1. Dimensions — Split base

The dimensions are given in mm.

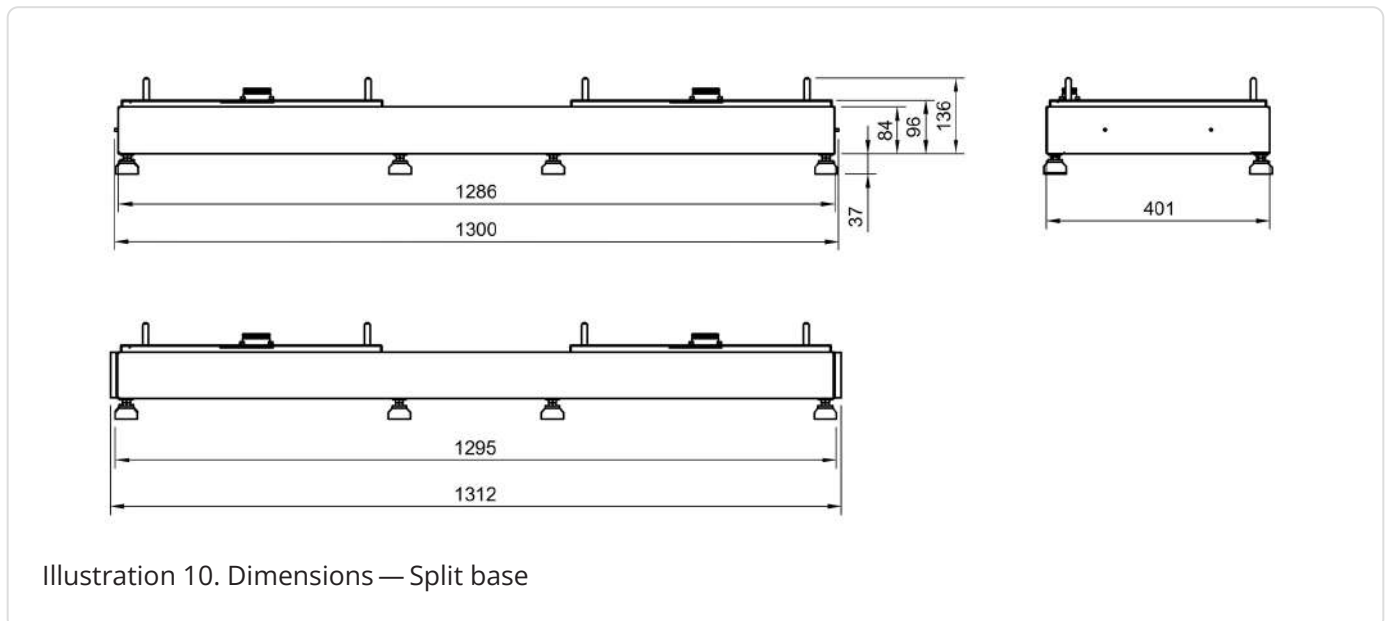


Illustration 10. Dimensions — Split base

3.10. Technical data — Top box (with option: split base)

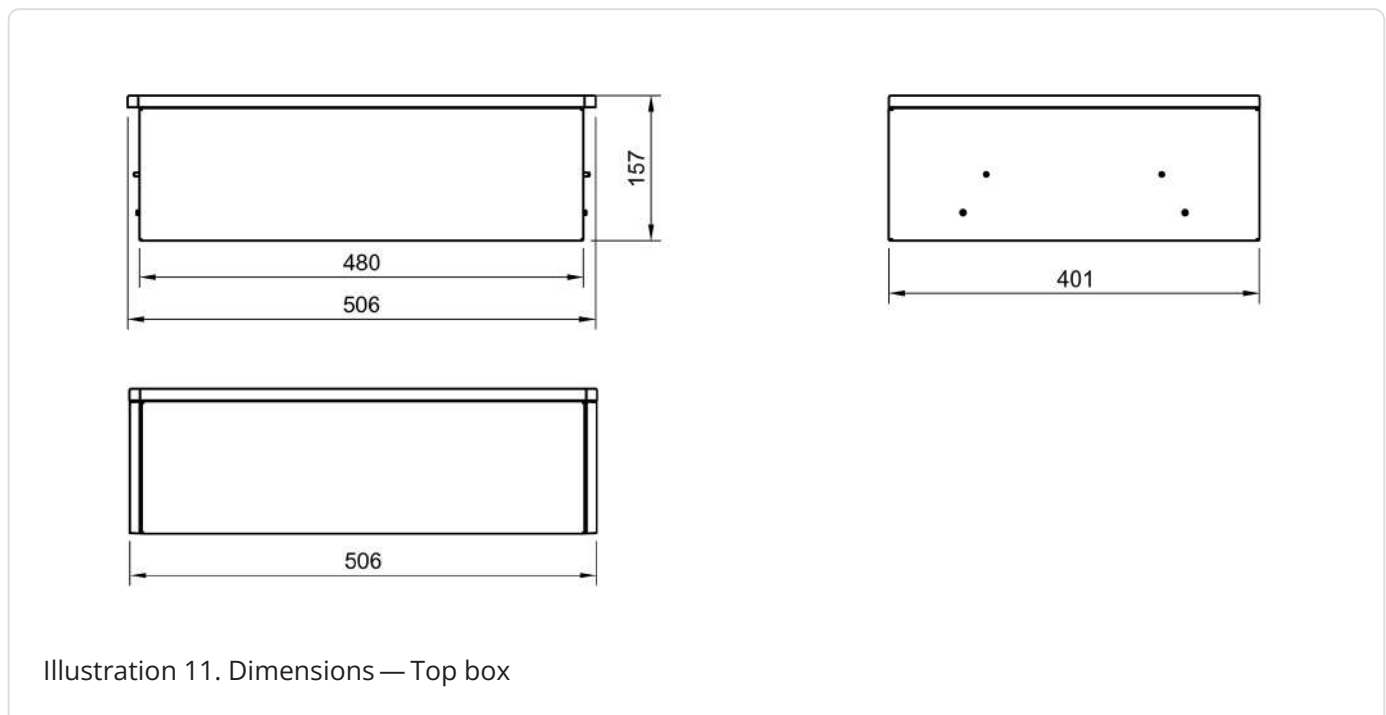
3.10. Technical data — Top box (with option: split base)

Description	Value/dimension
Width (incl. side panel) Depth Height	506 401 157 mm
Weight	9 kg
Protection specification	IP55 (plugged in)
Installation	stackable

Table 22. Technical data — Top box

3.10.1. Dimensions — Top box

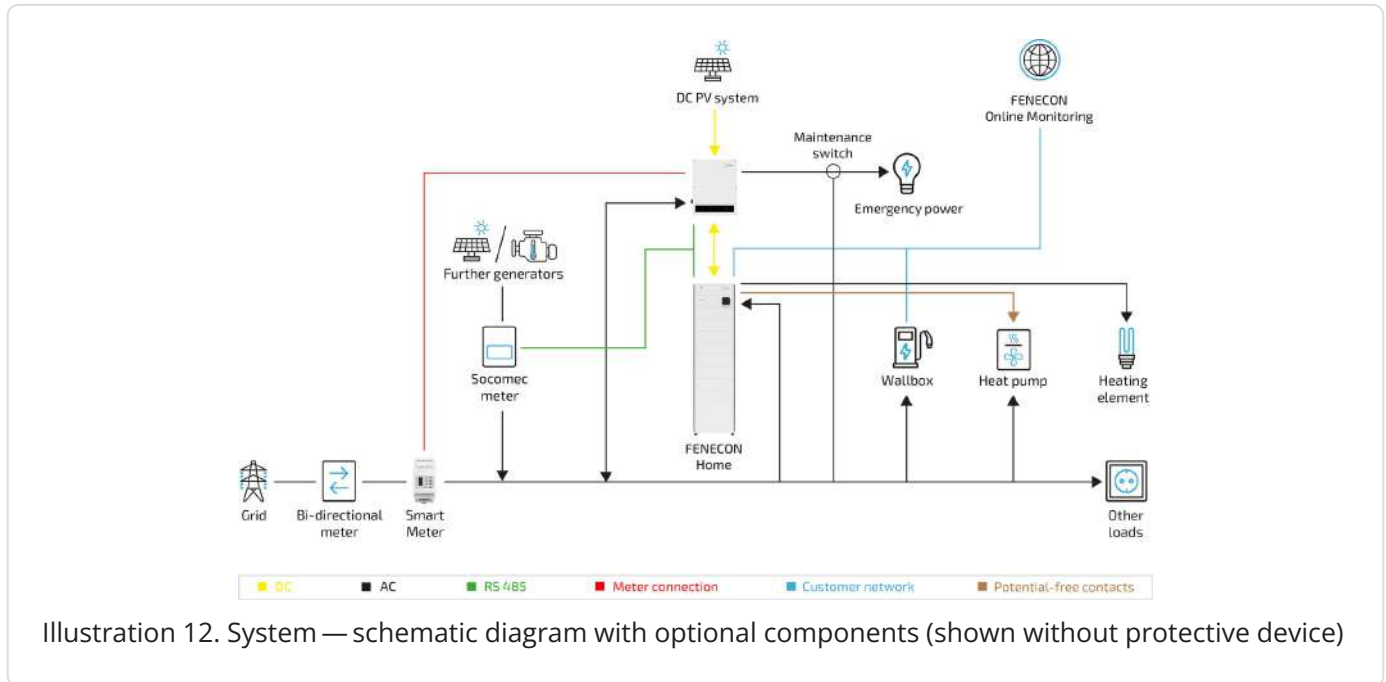
The dimensions are given in mm.



4. General description

The FENECON Home 20 & 30 is a Back-up power capability Battery energy storage system that can build its own household power grid. Lithium iron phosphate batteries (LiFePO4) are used in this modular system for storing electrical energy.

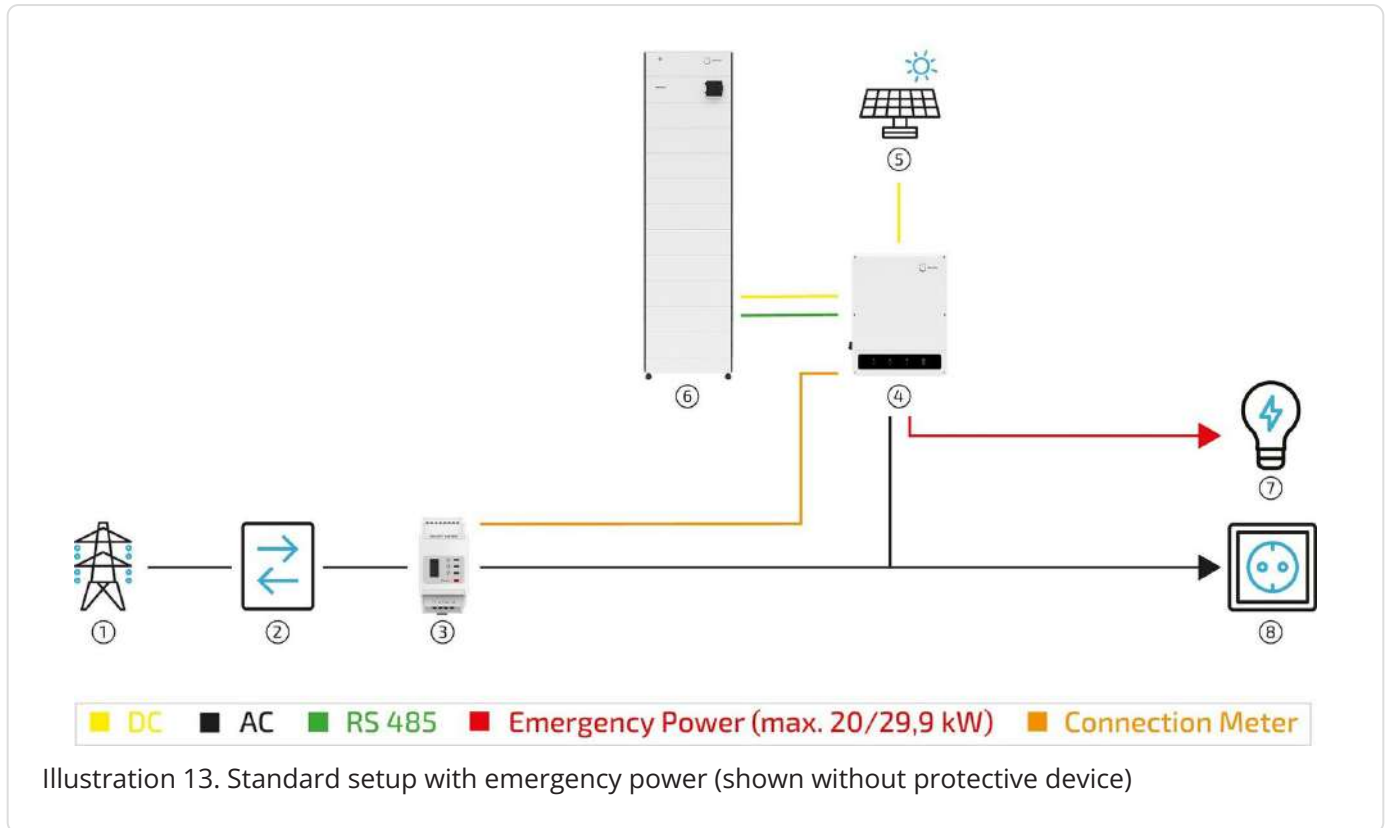
4.1. System configuration — General overview



4.2. System structure: Variants with emergency power

4.2. System structure: Variants with emergency power

4.2.1. Standard setup with back-up power



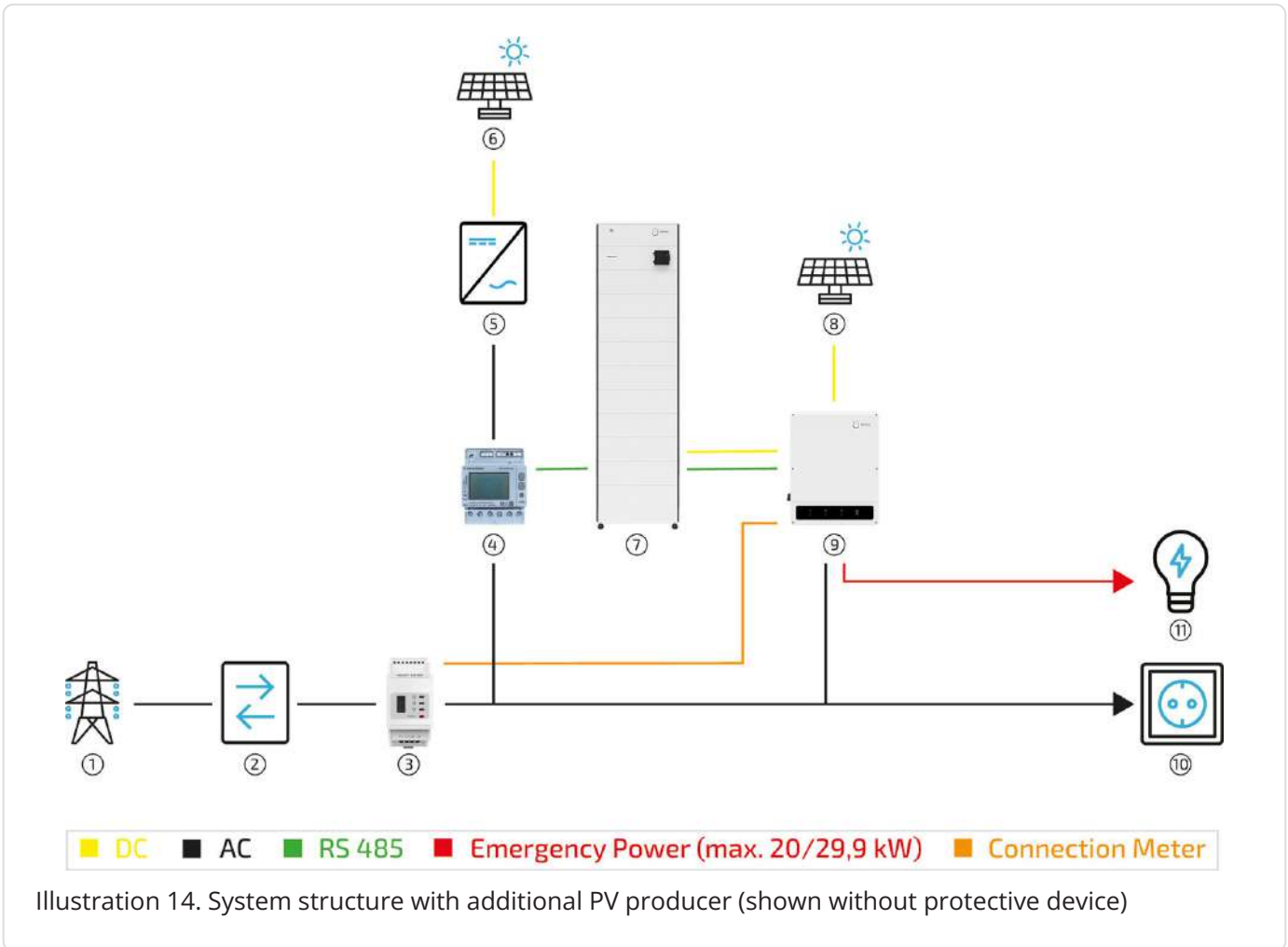
Item	Description
1	Grid
2	2 bi-directional meter
3	Smart meter
4	Inverter
5	PV system
6	FENECON Home 20 & 30
7	Consumption (emergency power supply)
8	Consumption (not supplied with emergency power)

Table 23. Standard setup with back-up power



Within the emergency power function, the Inverter acts as its own grid creator and sets up its own 3-phase system for the separate emergency power branch (see [Technical data](#)). Compared to the public grid system, the Grid shape of the emergency power mode has a lower "buffer effect" with regard to load peaks, starting currents, DC components and strongly fluctuating Loads. Due to the limited power of the Inverter, such loads are only possible within certain limits.

4.2.2. System structure with additional PV producer

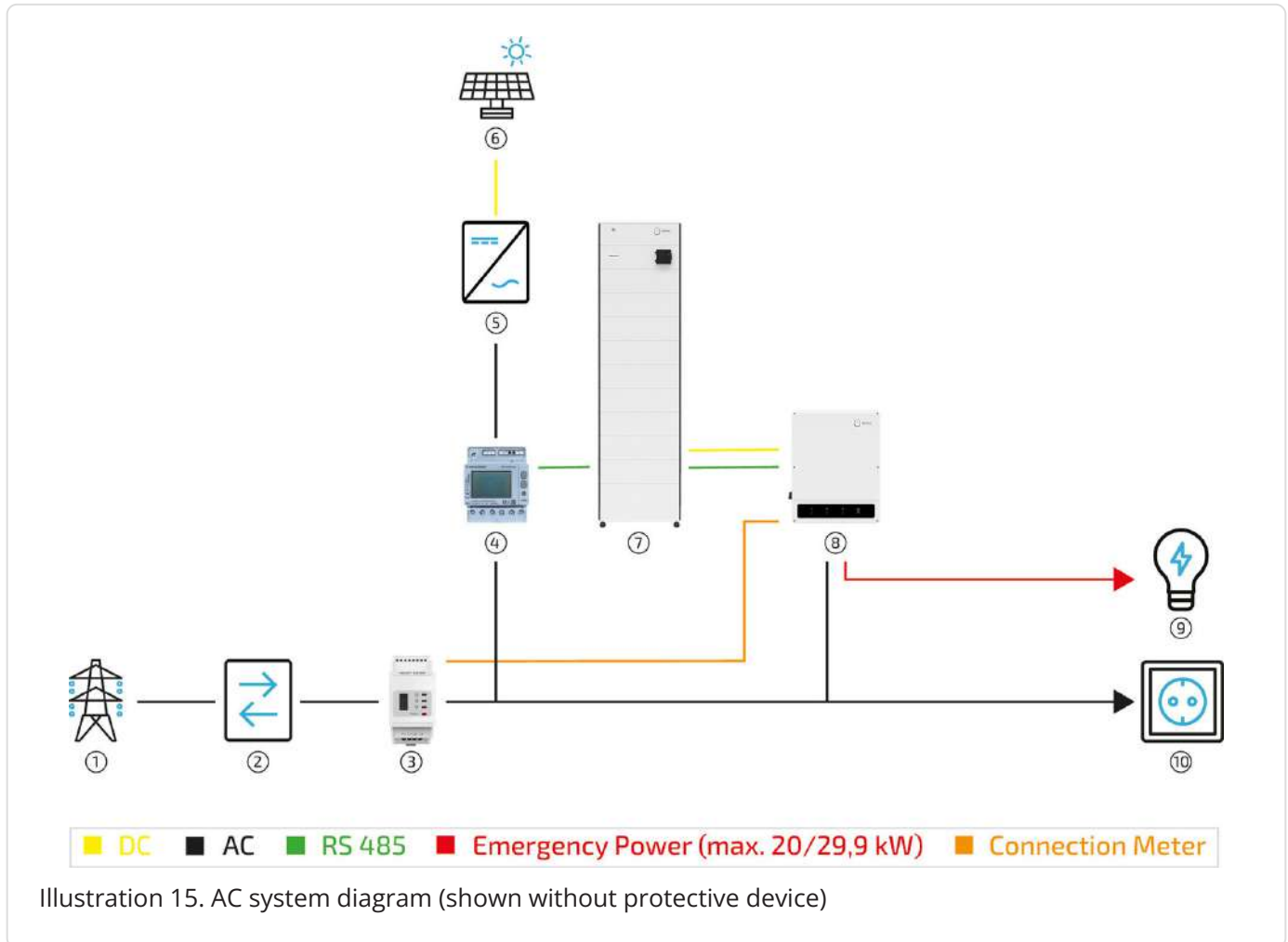


Item	Description
1	Grid
2	2 bi-directional meter
3	Smart meter
4	3-phase sensor or with PV inverter app
5	PV Inverter
6	Additional PV system
7	FENECON Home 20 & 30
8	PV system
9	Inverter
10	Consumption (not supplied with emergency power)
11	Consumption (emergency power supply)

Table 24. System structure with additional PV producer

4.2. System structure: Variants with emergency power

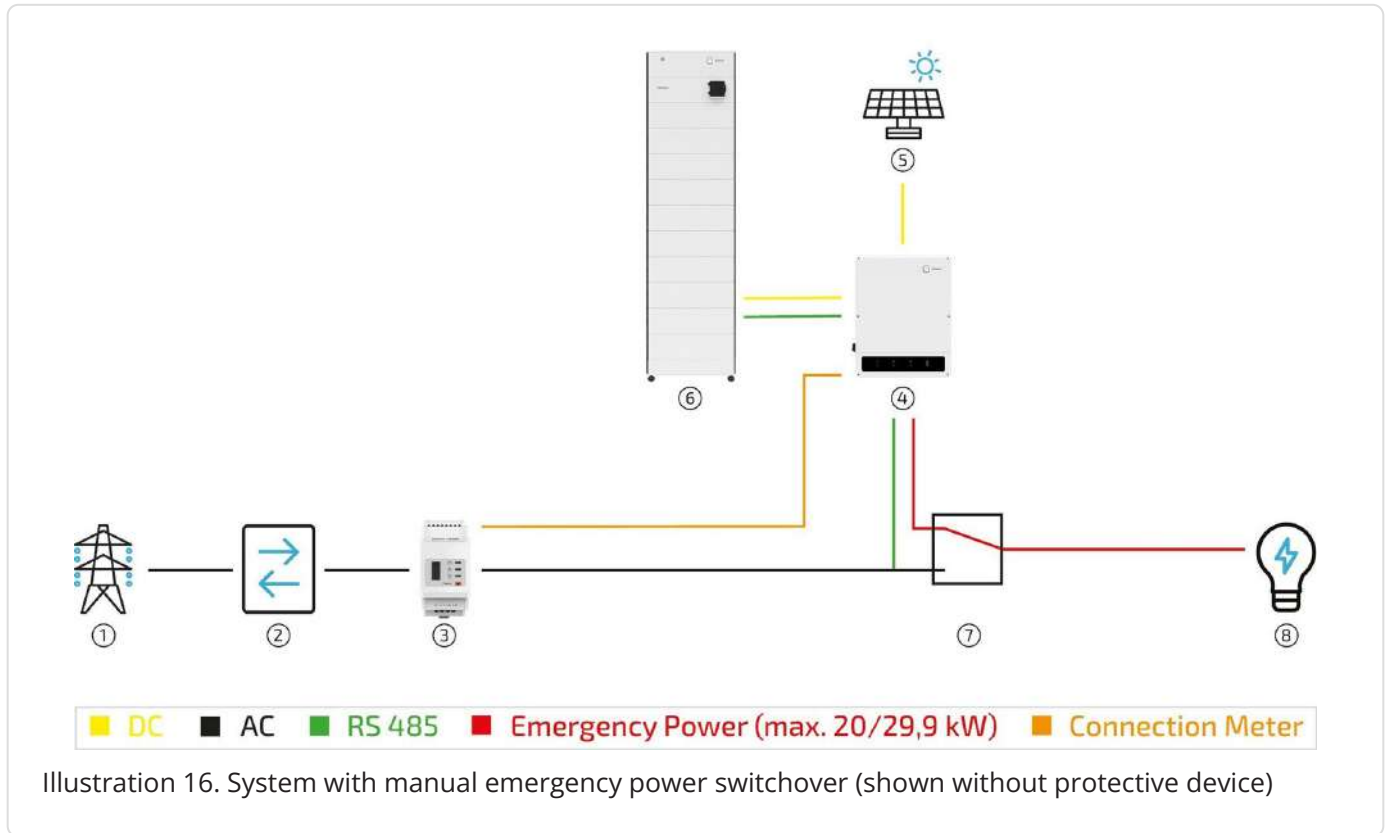
4.2.3. AC system diagram



Item	Description
1	Grid
2	2 bi-directional meter
3	Smart meter
4	3-phase sensor or with PV inverter app
5	PV Inverter
6	PV system
7	FENECON Home 20 & 30
8	Inverter
9	Consumption (emergency power supply)
10	Consumption (not supplied with emergency power)

Table 25. AC system diagram

4.2.4. System with manual emergency power changeover



Item	Description
1	Grid
2	2 bi-directional meter
3	Smart meter
4	Inverter
5	PV system
6	FENECON Home 20 & 30
7	Manual Back-up Power switch
8	Consumption (emergency power supply)

Table 26. System with manual emergency power changeover

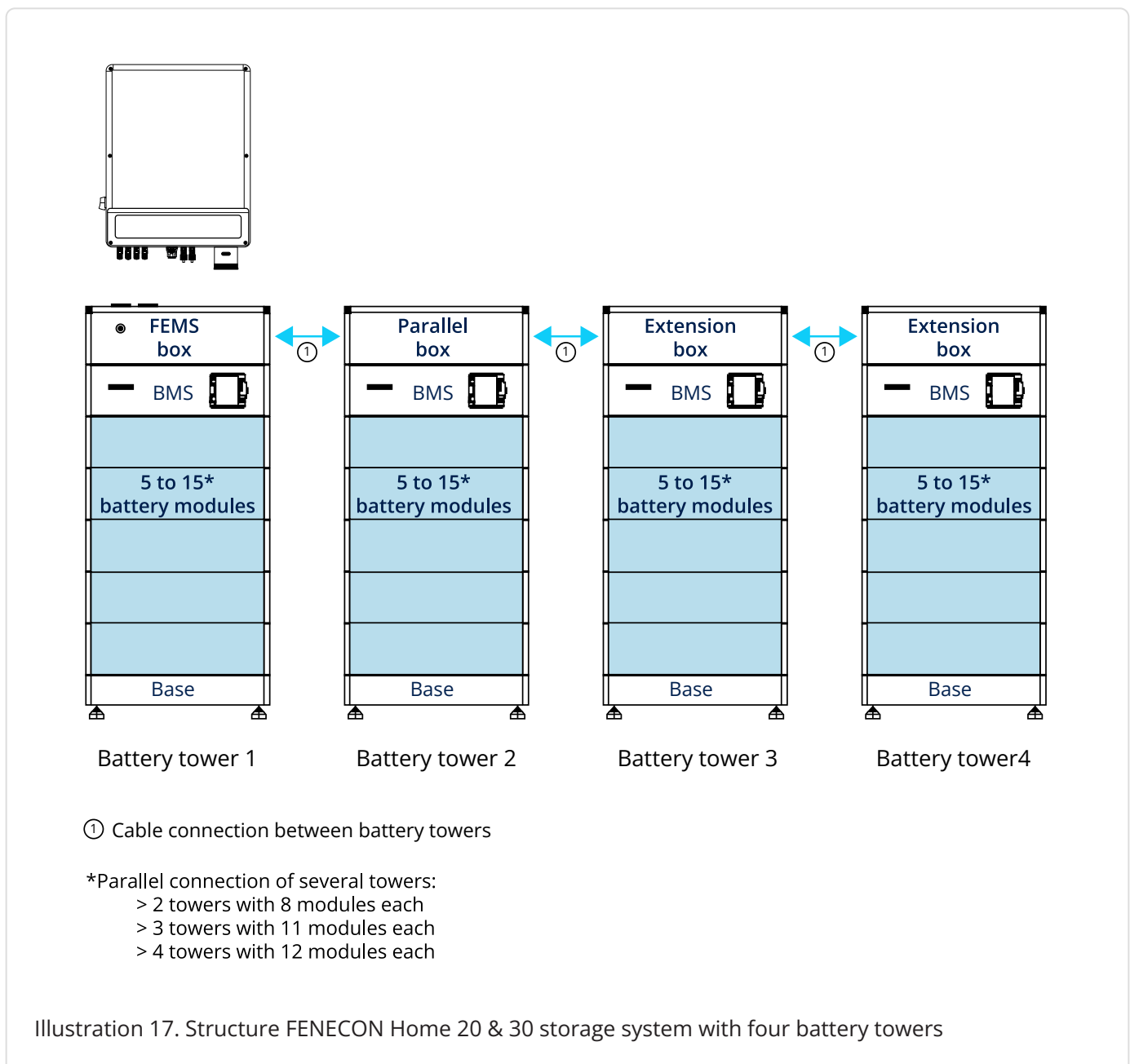
4.2. System structure: Variants with emergency power

4.2.5. Required components

Depending on the system configuration, a maximum of the following components is required. When connecting up to four battery towers in parallel, ensure that the same number of battery modules is installed in each battery tower.

Number of battery towers	Number of battery modules max.	BMS box (per tower)	EMS box	Parallel box	Extension box
1	15	1	1	-	-
2	30	1	1	1	-
3	45	1	1	1	1
4	60	1	1	1	2



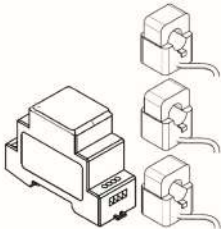
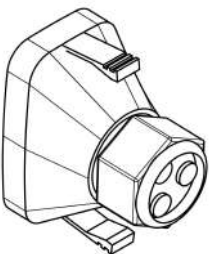
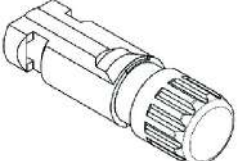
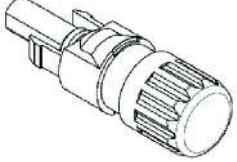

Table 27. System configuration — Required components



5. Assembly preparation

5.1. Scope of delivery

5.1.1. FENECON Home 20 & 30 inverter

Image	Amount	Description	Item no.
	1	FENECON Home 20 & 30-Inverter	FEH030 and FEH031
	1	Wall mount	FEH057
	1	Meter with transformer (transformers are already mounted on the meter)	FH0055
	1	Cover — communication connection	FEH060
	4(6)	MC4 plug	Part of complete set FEH055
	4(6)	MC4 socket	Part of complete set FEH055
	1	Energy meter cable	

5.1. Scope of delivery


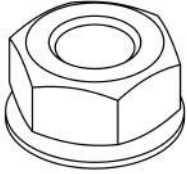
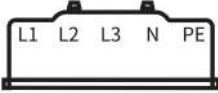

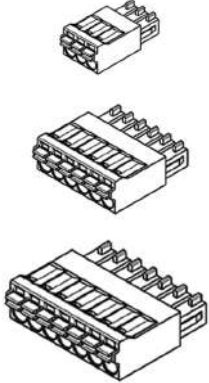
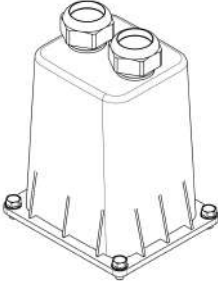

Image	Amount	Description	Item no.
	1	FEMS cable	Part of complete set FEH055
	20	Nuts for AC connection	Part of complete set FEH055
	1	Insulator plate for AC connections	Part of complete set FEH055
	10	Cable lugs — AC cable	Part of complete set FEH055
	1	Pin terminal, 3-pin	Part of complete set FEH055. [^]
	1	Pin terminal, 6-pin	Part of complete set FEH055
	1	Pin terminal, 7-pin	Part of complete set FEH055
	1	Cover — AC connection	FEH056
	2	Bolt for earthing and fixing to wall bracket	Part of complete set FEH055

Table 28. Scope of delivery — FENECON Home 20 & 30-Inverter

5.1. Scope of delivery

5.1.2. FENECON Home 20 & 30-EMS-Box

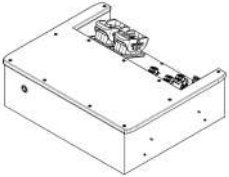
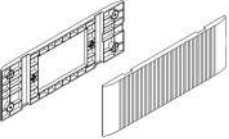
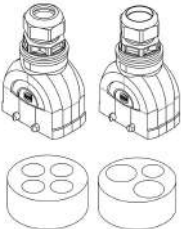
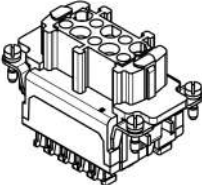
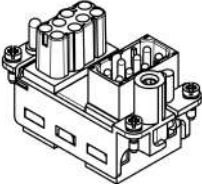
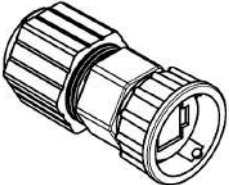
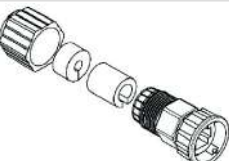

Image	Amount	Description	Item no.
	1	FENECON Home 20 & 30-EMS box	FEH013
	2	side panel	Part of complete set FEH050
	2	Harting housing with cable gland (13-21 mm), multi-hole seal (4 x 8 mm) Harting housing with cable gland (19-25 mm), multi-hole seal (2 x 10 & 1 x 8 mm)	Part of complete set FEH050
	1	Harting socket, 10-pin	Part of complete set FEH050
	1	Harting insert 16-pin (assembled)	Part of complete set FEH050
	1	Jumper plug	Part of complete set FEH050
	2	Network connector housing	Part of complete set FEH050
	5	Filler plug, 8 mm	Part of complete set FEH050






Image	Amount	Description	Item no.
	2	Filler plug, 10 mm	Part of complete set FEH050
	1	Battery cable set, 3 m	Part of complete set FEH050
	1	Installation and service instructions (for the installer)	
	1	Quick start guide (for the installer)	
	1	Operating instructions (for the end customer)	

Table 29. Scope of delivery — FENECON Home 20 & 30-EMS-Box

5.1. Scope of delivery

5.1.3. FENECON Home 20 & 30 Parallel box (optional)

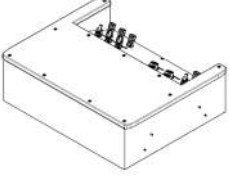
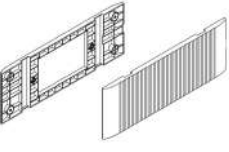


Image	Amount	Description	Item no.
	1	FENECON Home 20 & 30 Parallel box	FEH011
	2	side panel	Part of complete set FEH059
	2	Two DC cables per set, 2 m	Part of complete set FEH059
	1	Communication cable — parallel connection, 2 m	Part of complete set FEH059

Table 30. Scope of delivery — Parallel box

5.1.4. FENECON Home 20 & 30 extension box (optional)

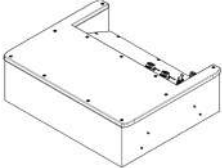
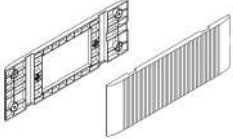


Image	Amount	Description	Item no.
	1	FENECON Home 20 & 30-Extension box	FEH012
	2	Side panel	Part of complete set FEH059
	2	two DC cables per set, 2 m	Part of complete set FEH059
	1	communication cable, 2 m	Part of complete set FEH059

Table 31. Scope of delivery — Extension box

5.1. Scope of delivery

5.1.5. FENECON Home 20 & 30-BMS-Box/Base

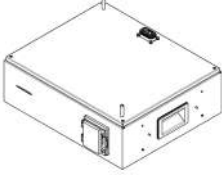
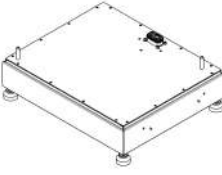
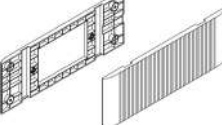
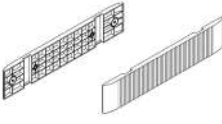

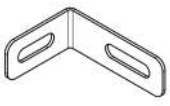


Image	Amount	Description	Item no.
	1	FENECON Home 20 & 30-BMS box	FEH000
	1	Base	
	2	Side panel (FENECON Home 20 & 30-BMS box)	FEH051
	2	Side panel (base)	
	4	Wall mounting — Mounting bracket	Part of connection set FEH052
	4	Wall mounting — Mounting bracket (wall part)	Part of connection set FEH052
	8	Bolt M4 x 10	Part of connection set FEH052
	2	Bolt for wall mounting M6 x 12	Part of connection set FEH052

Table 32. Scope of delivery — BMS box/base

5.1.6. BMS box/split base (optional)

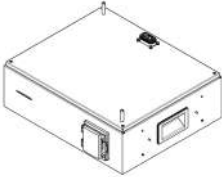
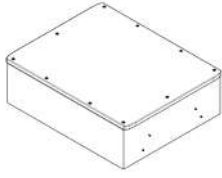

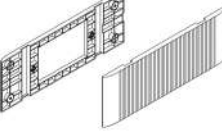
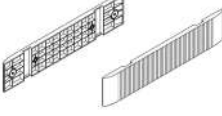
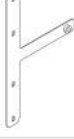



Image	Amount	Description
	1	BMS box for split base
	1	Top box for split base
	1	Split base
	4	Side panel (BMS box)
	2	Side panel (split base)
	4	Wall mounting — Mounting bracket
	4	Wall mounting — Mounting bracket (wall part)
	4	Bolts, M4 x 10
	2	Bolts for wall mounting, M6 x 12

Table 33. Scope of delivery — BMS box/split base (optional)

5.1. Scope of delivery

5.1.7. FENECON Home 20 & 30 battery module


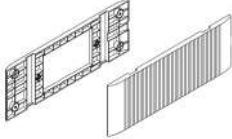


Image	Amount	Description	Item no.
	1	Battery module	FEH020
	2	Side panel	FEH051
	2	Fixing plates	Part of connection set FEH053
	2	Bolt M4 x 10	Part of connection set FEH053

Table 34. Scope of delivery — Battery module

5.2. Tools required

The following tools are required for assembly of the system components:


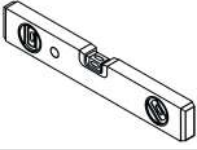

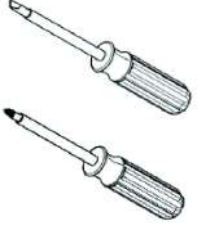




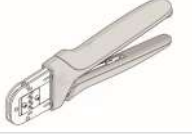





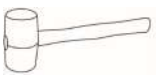





Image	Description	Image	Description
	Pencil		Spirit level
	Impact drill or cordless screwdriver		Screwdriver set
	Meter stick		Side cutter
	Allen key, 3 mm		Set of flat spanners
	Crimping tool		Multimeter
	Pliers for cable glands		Protective eyewear
	Safety footwear		Dust mask
	Rubber mallet		Vacuum cleaner
	Wire stripper		Protective gloves
	Torque wrench		Stripping knife

Table 35. Tools required

6. Assembly



- Do not damage any cables and make sure that nobody steps on the cables or plugs! Damage can lead to serious malfunctions!
- If cables are fed in from the front, the customer must use suitable covers to protect the cables against the risk of tripping.



- Ensure that all devices in the same network and the battery modules are integrated into the existing surge protection.



- When drilling holes, avoid the water pipes and cables laid in the wall.
- Wear protective eyewear and a dust mask when drilling to prevent dust from being inhaled or getting into your eyes when drilling holes.
- Make sure that the inverter is securely installed.
- The DC switch lock of a suitable size should be prepared by the customer. The diameter of the lock is 5 mm. The lock may not be installed if the size is not appropriate.
Please refer to the supply documentation of the inverter.



Suitable protective covers must be fitted!
All local accident prevention regulations must be observed.

The following components must be installed:

- Inverter
- Battery tower with Base, battery modules, BMS-Box, and FENECON Home 20 & 30-EMS-Box
- Optional:
Battery tower with base, battery modules, BMS box and Parallel box
- Optional:
Battery tower with base, battery modules, BMS box and Extension box

Before installation, carefully check whether the packaging and products are damaged and whether all accessories listed in the [Scope of delivery](#) are included. If a part is missing or damaged, contact the manufacturer/dealer.

6.1. Assembly — Inverter

6.1.1. Safety instructions

Electric shock from live parts

Death or serious injury to the body and limbs from electric shock when touching live DC cables connected to the electrical energy storage system.



- Before starting work, disconnect the inverter, the BMS box and the battery modules from the power supply and secure them against being switched on again.
- Wait at least 5 minutes after switching off before starting work on the inverter.
- Observe the safety instructions of FENECON GmbH in the [Safety](#) section.
- Do not touch any exposed live parts or cables.
- Do not pull the terminal strip with connected DC conductors out of the slot under consumer load.
- Wear suitable personal protective equipment for all work.

Electric shock in the absence of overvoltage protection

Death or serious injury to the body and limbs from electric shock due to overvoltage (e. g. lightning strike) transmitted via the network cables or other data cables into the building and to other connected devices in the same network due to a lack of overvoltage protection.



- Ensure that all devices in the same network and the battery modules are integrated into the existing surge protection
- When laying network cables or other data cables outdoors, ensure that suitable overvoltage protection is in place when the cables from the inverter or battery tower (battery modules) pass from the outdoor area into a building.
- The Ethernet interface of the inverter is classified as "TNV-1" and offers contactor protection against overvoltages of up to 1.5 kV.

Fire and explosion

Death or serious injury to body and limbs due to fire or explosion; in the event of a fault, an ignitable gas mixture may be produced inside the inverter. Switching operations in this condition can cause a fire inside the product or tripped an explosion.



- In the event of a fault, do not carry out any direct actions on the electrical energy storage system.
- Ensure that unauthorized persons do not have access to the electrical energy storage system.
- Disconnect the battery modules from the inverter via the DC fuse on the battery tower.
- Switch off the AC miniature circuit breaker or, if it has already tripped, leave it switched off and secure it against being switched on again.
- Only carry out work on the inverter (e.g. troubleshooting, repair work) with personal protective equipment for handling hazardous substances (e.g. protective gloves, eye and face protection and respiratory protection).

Fire and explosion with deeply discharged battery modules

Death or serious injury to body and limbs from fire or explosion due to incorrect charging of deeply discharged battery modules



- Before commissioning the system, ensure that the battery modules are not deeply discharged.
- Do not operate the system if the battery modules are deeply discharged.
- If the battery modules are deeply discharged, contact Service
- Only charge deeply discharged battery modules as instructed by the Service.

**Toxic substances, gases and dusts**

Damage to electronic components can result in toxic substances, gases and dusts inside the inverter. Touching toxic substances and inhaling toxic gases and dusts can cause skin irritation, chemical burns, breathing difficulties and nausea.

- Only carry out work on the inverter (e.g. troubleshooting, repair work) with personal protective equipment for handling hazardous substances (e.g. protective gloves, eye and face protection and respiratory protection).
- Ensure that unauthorized persons do not have access to the inverter.

**Arcs due to short-circuit currents**

Death or serious injury to the body and limbs due to burns caused by heat development and electric arcs due to short-circuit currents from the battery modules.

- Before carrying out any work on the battery modules, de-energize the battery modules.
- Comply with all safety instructions from the battery manufacturer.

**Destruction of a measuring device due to overvoltage**

Death or serious injury to the body and limbs due to electric shock when touching a live meter housing: An overvoltage can damage a meter and lead to a voltage being applied to the meter housing.

- Only use measuring devices with a DC input voltage range of at least 600 V or higher.

6.1. Assembly — Inverter

Hot surfaces

Injuries to the body and limbs due to burning on hot surfaces: The surface of the inverter can become very hot.



- Mount the inverter in such a way that it cannot be touched accidentally.
- Do not touch hot surfaces.
- Before starting work, wait 30 minutes until the surface has cooled down sufficiently.
- Observe the warning notices on the inverter.

Weight of the inverter

Injuries to the body and limbs due to crushing when falling during transportation or assembly of the inverter



- Transport and lift the Inverter carefully.
- Note the weight of the Inverter and its center of gravity
- Wear suitable personal protective equipment when working on the inverter.



Sand, dust and moisture

Ingress of sand, dust and moisture can damage the inverter and impair its function.



Electrostatic charge

Touching electronic components can damage or destroy the inverter via electrostatic discharge.

- Ground yourself before touching a component.

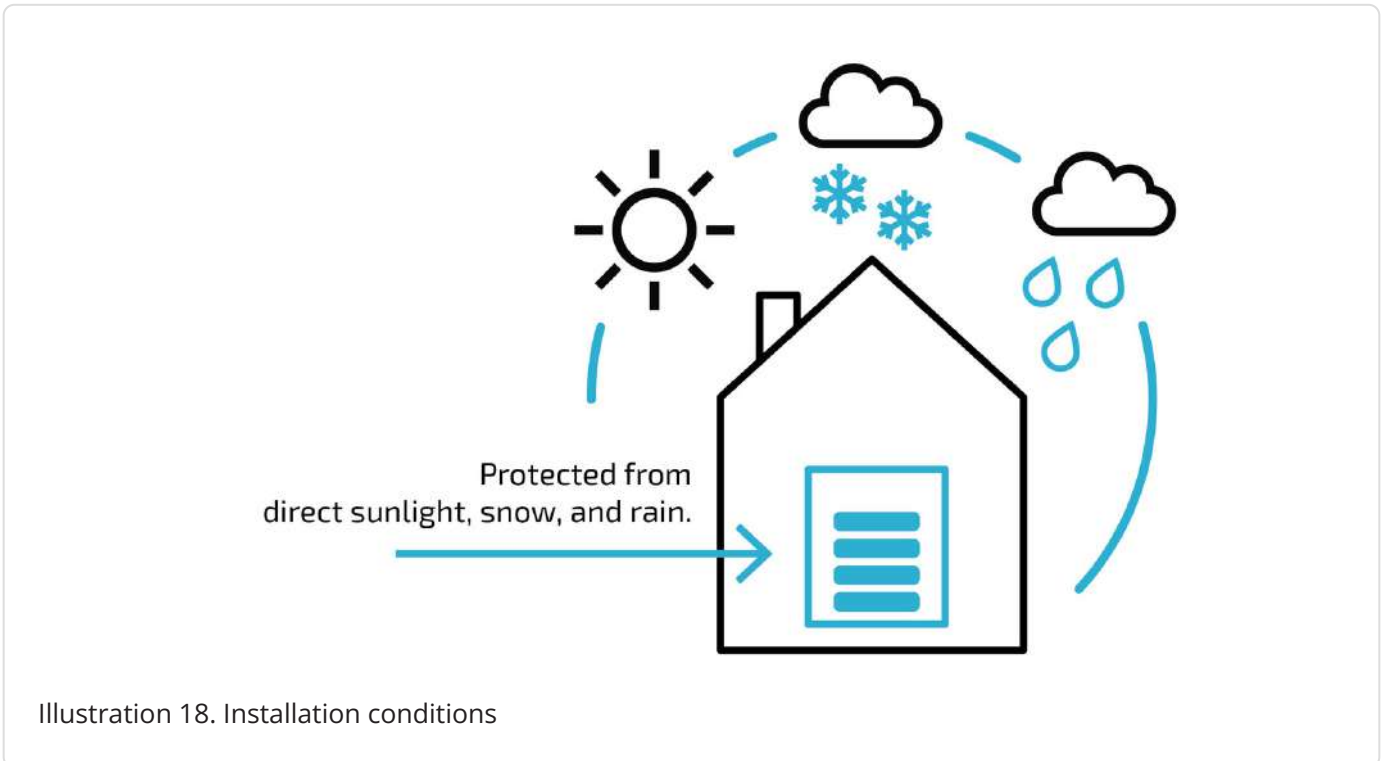


Cleaning agents

The use of cleaning agents can damage the inverter and parts of the inverter.

- Only clean the inverter and all its parts with a cloth moistened with clean water.

6.1.2. Installation conditions and clearances at the installation site



- The inverter must be installed away from direct sunlight and protected from direct rain and snow.

6.1. Assembly — Inverter

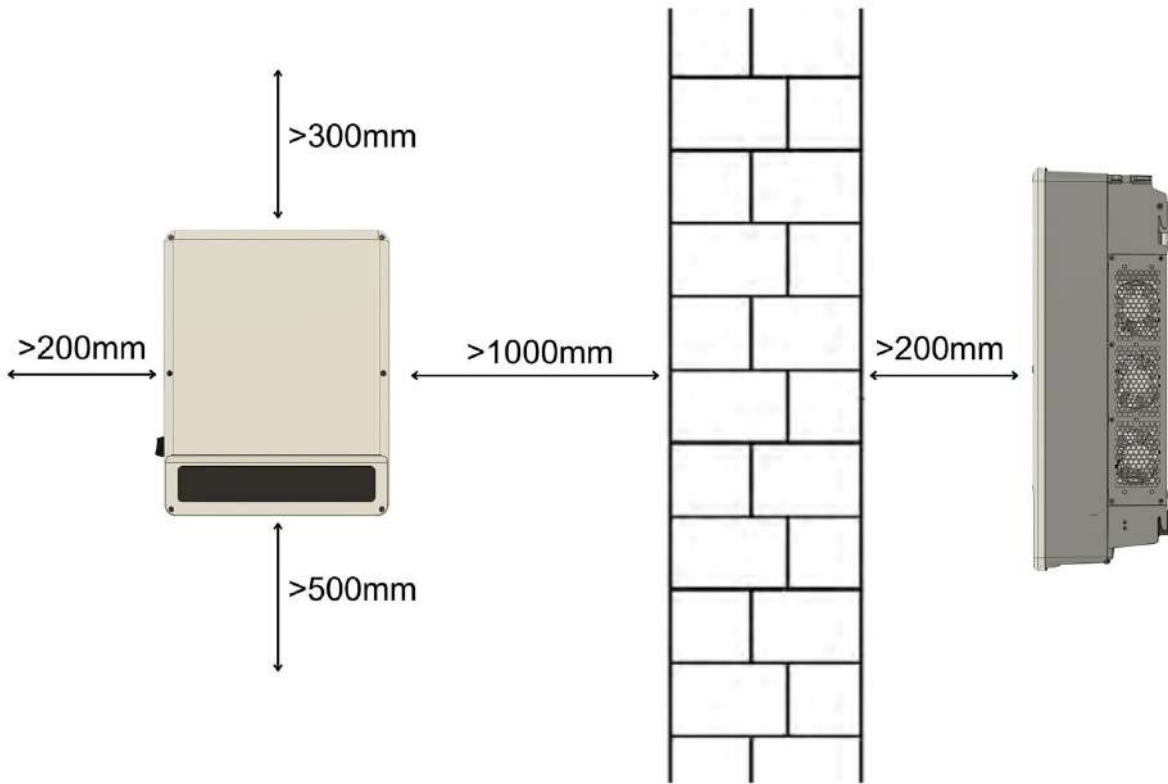


Illustration 19. Recommended distances at the installation site

Installation conditions



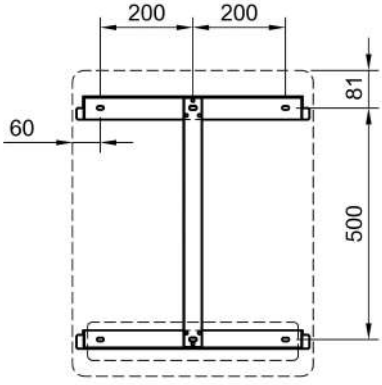
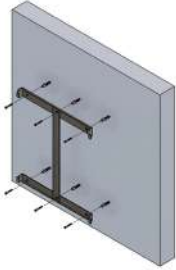


- The wall must be stable enough for mounting the Inverter and must not be flammable.
- Maintain a distance of at least 300 mm above the Inverter.
- Keep a distance of at least 500 mm below the Inverter (cable ducts are not measured here).
- Maintain a clearance of at least 300 mm from the front of the inverter.
- Laterally: Keep a distance of at least 200 mm to the left of the Inverter and at least 1000 mm to the right.
- The maximum distance between the Inverter and the installation location of the meter should be based on the cable supplied (10 m). The cable between the meter and the Inverter can be extended up to 100 m.
- The pre-installed current transformers must not be shortened or extended.

6.1. Assembly — Inverter

6.1.3. Assembly

To install the FENECON Home 20 & 30 inverter on the wall, proceed as follows:

Assembly of the wall bracket

	<ol style="list-style-type: none"> 1. Mark and drill the holes for the wall bracket (Ø 8 mm, depth 80 mm). 2. Observe minimum clearances.
	<ol style="list-style-type: none"> 3. Mount the wall bracket on the wall. Always check the condition of the wall to see whether the screw anchors can be used.
	<ol style="list-style-type: none"> 4. Hook the inverter into the wall mount at the top and bottom using the handles.
	<ol style="list-style-type: none"> 5. Then secure on the right-hand side using the enclosed screw.

6.2. Assembly of battery tower 1 with FEMS box

6.2.1. Safety instructions

Electric shock from live parts

Death or serious injury to the body and limbs from electric shock when touching live DC cables connected to the electrical energy storage system.



- Before starting work, de-energize the inverter, the BMS box and the battery modules and secure them against being switched on again.
- Wait at least 5 minutes after switching off before starting work on the inverter.
- Observe all the manufacturer's safety instructions in section 2 [Safety](#).
- Do not touch any exposed live parts or cables.
- Do not pull the terminal strip with connected DC conductors out of the slot under consumer load.
- Wear suitable personal protective equipment for all work.

Electric shock in the absence of overvoltage protection

Death or serious injury to the body and limbs from electric shock due to overvoltage (e. g. lightning strike) transmitted via the network cables or other data cables into the building and to other connected devices in the same network due to a lack of overvoltage protection.



- Ensure that all devices in the same network and the battery modules are integrated into the existing surge protection.
- When laying network cables or other data cables outdoors, ensure that suitable overvoltage protection is in place when the cables from the inverter or battery tower (battery modules) pass from the outdoor area into a building.
- The Ethernet interface of the inverter is classified as "TNV-1" and offers contactor protection against overvoltages of up to 1.5 kV.

6.2. Assembly of battery tower 1 with FEMS box

Fire and explosion

Death or serious injury to the body and limbs due to fire or explosion; in the event of a fault, an ignitable gas mixture may be produced inside the battery module. Switching operations in this condition can cause a fire inside the product or tripped an explosion.



- In the event of a fault, do not carry out any direct actions on the electrical energy storage system.
- Ensure that unauthorized persons do not have access to the electrical energy storage system.
- Disconnect the battery modules from the inverter using an external disconnecting device.
- Switch off the AC miniature circuit breaker or, if it has already tripped, leave it switched off and secure it against being switched on again.
- Only carry out work on the inverter (e.g. troubleshooting, repair work) with personal protective equipment for handling hazardous substances (e.g. protective gloves, eye and face protection and respiratory protection).

Fire and explosion with deeply discharged battery modules

Death or serious injury to the body and limbs due to electric shock when touching a live meter housing: Overvoltage can damage a meter and lead to a voltage being applied to the meter housing.



- Before commissioning the system, ensure that the battery modules are not deeply discharged.
- Do not operate the system if the battery modules are deeply discharged.
- If the battery modules are deeply discharged, contact Service.
- Only charge deeply discharged battery modules as instructed by the Service.

Toxic substances, gases and dusts

Damage to electronic components can result in toxic substances, gases and dusts inside the inverter. Touching toxic substances and inhaling toxic gases and dusts can cause skin irritation, chemical burns, breathing difficulties and nausea.



- Only carry out work on the inverter (e.g. troubleshooting, repair work) with personal protective equipment for handling hazardous substances (e.g. protective gloves, eye and face protection and respiratory protection).
- Ensure that unauthorized persons do not have access to the inverter.

**Arcs due to short-circuit currents**

Death or serious injury to the body and limbs due to burns, heat development and electric arcs due to short-circuit currents from the battery modules.

- Before carrying out any work on the battery modules, de-energize the battery modules.
- Comply with all safety instructions from the battery manufacturer.

**Destruction of a measuring device due to overvoltage**

Death or serious injury to the body and limbs due to electric shock when touching a live housing of a measuring device. An overvoltage can damage a measuring device and lead to a voltage being applied to the housing of the measuring device.

- Only use measuring devices with a DC input voltage range of at least 600 V or higher.

**Hot surfaces**

Injuries to the body and limbs due to burning on hot surfaces: The surface of the inverter can become very hot.

- Mount the inverter in such a way that it cannot be touched accidentally.
- Do not touch hot surfaces.
- Before starting work, wait 30 minutes until the surface has cooled down sufficiently.
- Observe the warning notices on the inverter.

**Weight of the battery modules**

Injuries to the body and limbs due to crushing if dropped during transportation or assembly of the battery modules.

- Carefully transport and lift the battery modules.
- Note the weight of the battery modules and its center of gravity.
- Wear suitable personal protective equipment when working on the battery modules.

6.2. Assembly of battery tower 1 with FEMS box



Sand, dust and moisture

Ingress of sand, dust and moisture can damage the inverter and impair its function.

- Only set up the battery tower where the humidity is within the limit values and the environment is free of sand and dust.



Electrostatic charging

Touching electronic components can damage or destroy the battery tower via electrostatic discharge.

- Ground yourself before touching a component.



Cleaning agents

The use of cleaning agents can damage the inverter and parts of the inverter.

- Clean the battery tower and all parts of the inverter exclusively with a damp cloth moistened with clear water.



Installation site

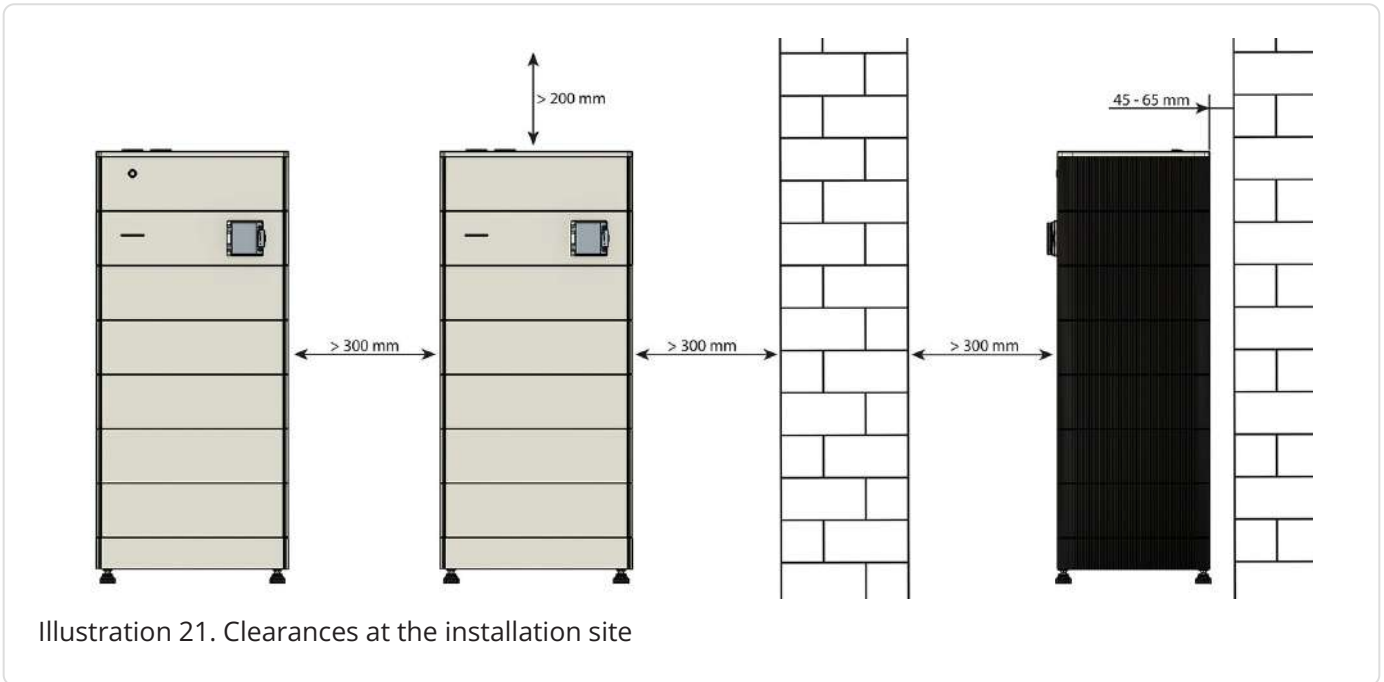
- It is recommended to install the battery tower indoors.
- If installed outdoors, weather protection (sun and precipitation protection) must be provided.
- Avoid dirt and dust during assembly.
- Do not install the battery tower in an area that is at risk of flooding.
- Do not install the battery tower in very damp areas (e. g. bathrooms).
- Do not install the battery tower where the ambient conditions are outside the permissible values (section [Technical data](#)).
- Keep the battery tower away from heat sources and fire.
- Ensure direct contact between the battery module housing and the ambient air and do not cover or shield the battery module.



Installation

- Wear protective eyewear, insulating gloves and protective footwear when assembling the battery modules.
- Remove all conductive jewelry (e.g. watches, bracelets, rings).

6.2. Assembly of battery tower 1 with FEMS box



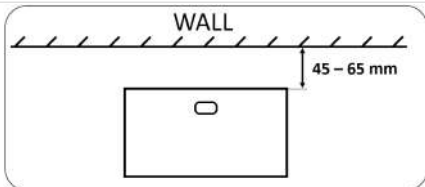
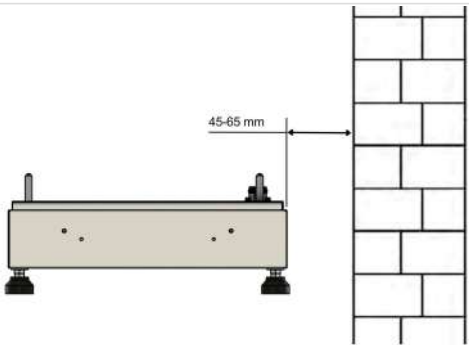
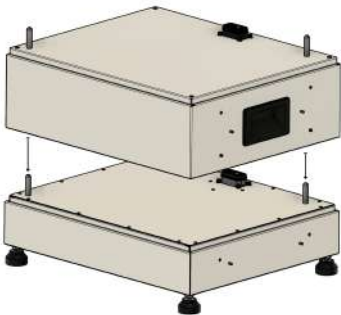
- A lateral clearance of 300 mm from a wall and 300 mm between two battery towers is recommended.
- Clearances of 300 mm from a wall are recommended at the front.
- The FENECON Home 20 & 30 battery tower and Inverter should be installed/mounted one above the other. If there is not enough space above, the battery tower and inverter can also be installed next to each other.
- A clearance of 200 mm from the ceiling is recommended.



If the recommended distances are not observed, installation may be more difficult and derating may occur earlier.

6.2.4. Assembly of battery tower 1 with FENECON Home 20 & 30 EMS box

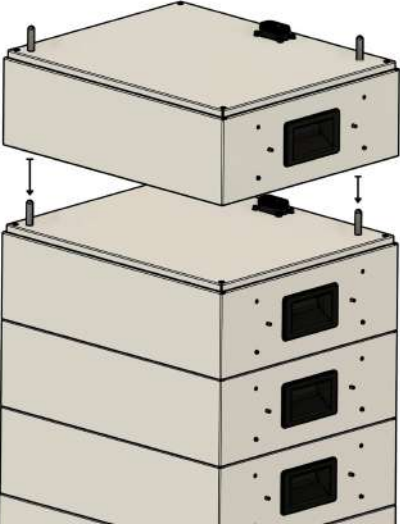
Proceed as follows to set up the battery tower:

	<ol style="list-style-type: none"> 1. The battery tower is installed stackable in front of a wall on a solid and level floor. 2. The clearance to the wall must be 40 to 65 mm so that the wall bracket can be fitted correctly.
	<ol style="list-style-type: none"> 3. Place the base on the feet at the installation location (maintain a clearance of 40 to 65 mm from a wall).
	<ol style="list-style-type: none"> 4. Place an FENECON Home 20 & 30 battery module on the base, paying attention to the plug-in bolts and positioning holes. 5. A black protective film may be stuck to the electrical connectors of the battery. If present, remove this before plugging together.



A maximum of 15 FENECON Home 20 & 30 battery modules can be stacked on one Base.

6.2. Assembly of battery tower 1 with FEMS box

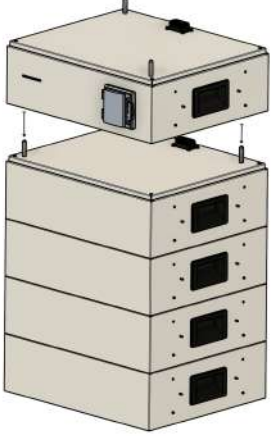

	<p>6. Mount all remaining FENECON Home 20 & 30 battery modules in the same way. Between 5 and 15 battery modules can be stacked.</p>
---	--



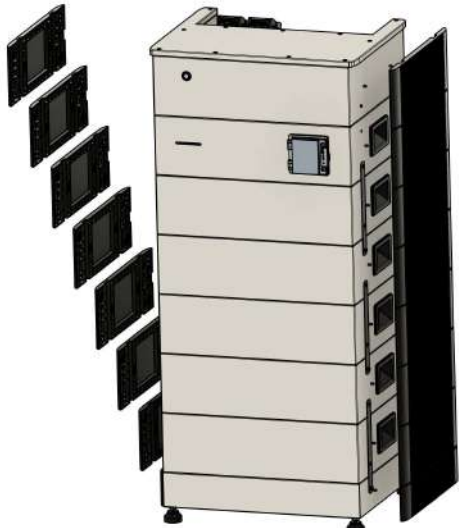


Electric shock

Death or serious injury to the body and limbs due to electric shock.

- Ensure that the circuit breaker of the BMS box is switched off before installing the BMS box.

	<p>7. Place the FENECON Home 20 & 30 BMS box on the last battery.</p>
	<p>8. Attach FENECON Home 20 & 30 EMS box.</p>

	<p>9. Mount the T-piece and the bracket with the enclosed M6 bolt.</p>
	<p>10. Hook in the mounting rails of the EMS box (wall side) and mark the holes for the wall bracket on the wall (see previous picture).</p> <p>11. Drill the holes and screw the wall bracket to the wall.</p> <p>12. Hook in all other rails alternately left/right one module lower and screw on with the enclosed bolts.</p> <p>13. The following bracket arrangement is recommended for attaching the battery towers. From 10 battery modules, two holders must be used on each side.</p>
	<p>14. Insert the side panels of the base, the battery modules, the BMS box and the EMS box.</p>

6.2. Assembly of battery tower 1 with FEMS box

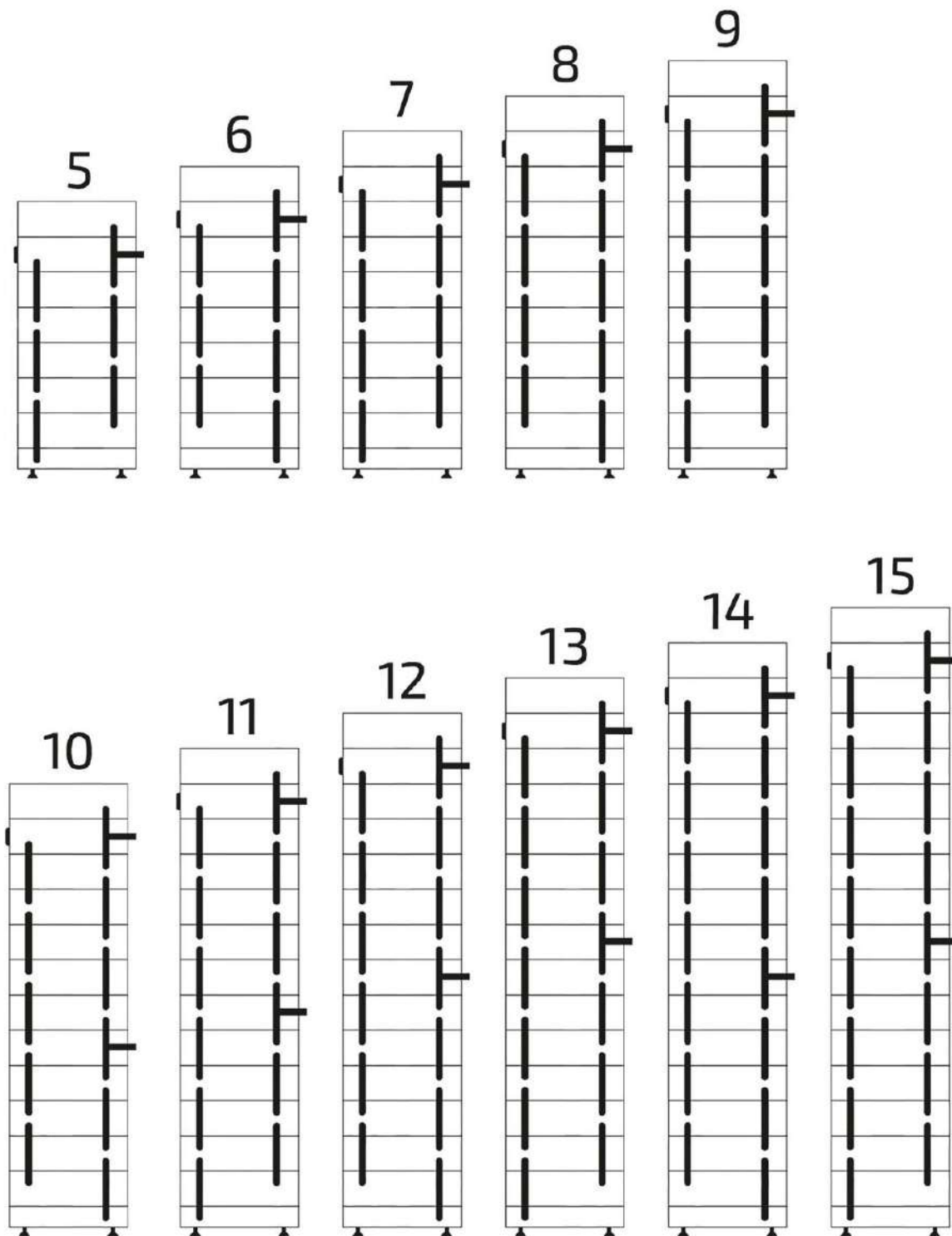


Illustration 22. Arrangement of the module fastening



You will find the assembly instructions for 2 or 3 battery towers in the section [\[Assembly of additional battery towers\]](#).

6.3. Installation — Battery tower on split base

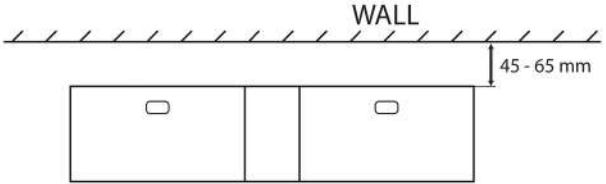
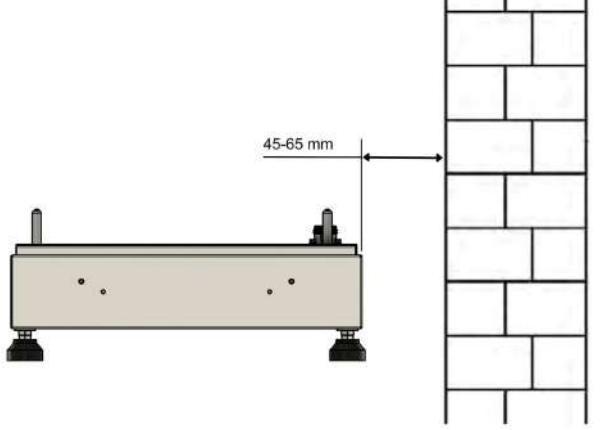
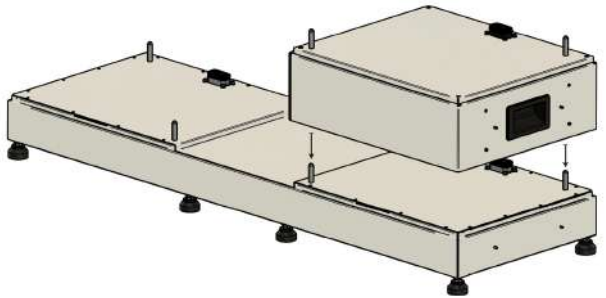


The split base can only be used with battery modules with item number FEH021.



The split base is used for a larger footprint installation **of a battery tower**, which reduces its height and enables installation in rooms with low ceilings.

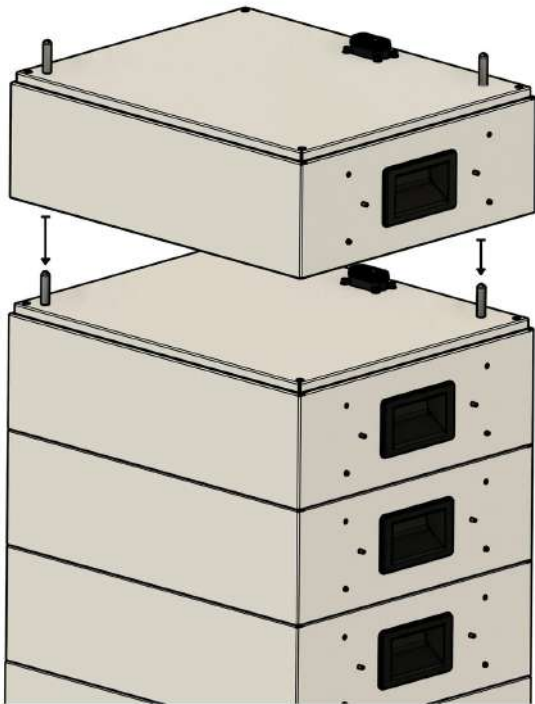
Proceed as follows to set up a battery tower with a split base:

	<ol style="list-style-type: none"> 1. The battery tower is installed stackable in front of a wall on a solid and level floor. 2. The clearance to the wall must be 40 to 65 mm so that the wall bracket can be fitted correctly.
	<ol style="list-style-type: none"> 3. Place the base on the feet at the installation location (maintain a clearance of 40 to 65 mm from a wall).
	<ol style="list-style-type: none"> 4. Place a battery module on the base, paying attention to the plug-in bolts and positioning holes. 5. A black protective film may be stuck to the electrical connectors of the battery. If present, remove this before plugging together.



- A maximum of 15 battery modules can be mounted on one split base.
- Ensure that the modules are evenly distributed on both sides of the split base.
- The difference in tower height must not exceed 5 modules.
If this cannot be complied with, a maximum of 10 battery modules must be stacked on one side of the system.

6.3. Installation — Battery tower on split base



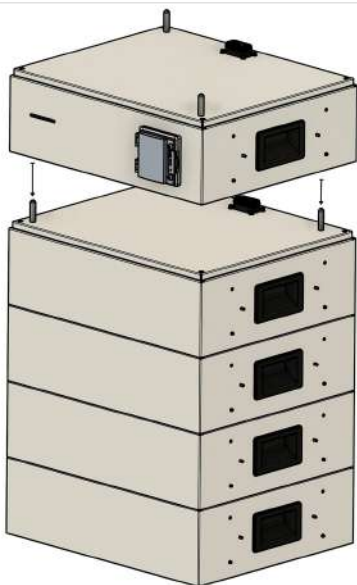
6. Install all remaining battery modules in the same way.

Electric shock

Death or serious injury to the body and limbs due to electric shock.



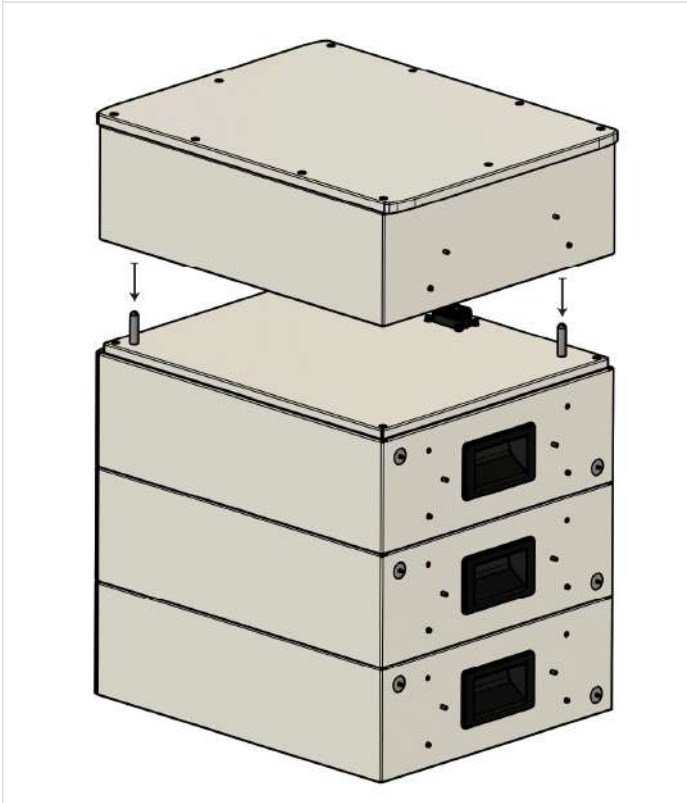
- Ensure that the circuit breaker of the BMS box is switched off before installing the BMS box.



7. Place the FENECON BMS box on the last battery. It does not matter which of the two towers on the split base the FENECON BMS box is placed on.

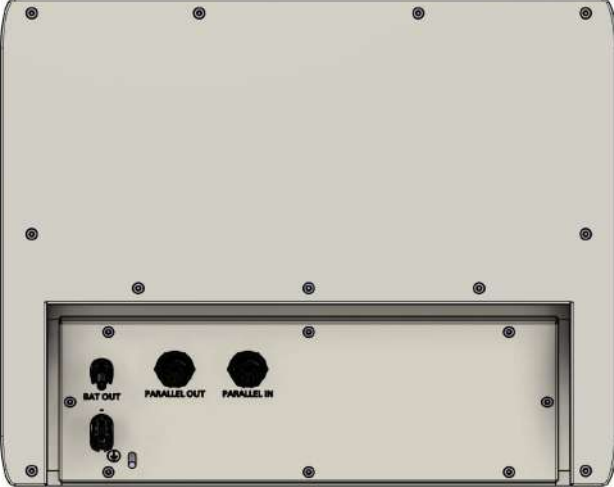

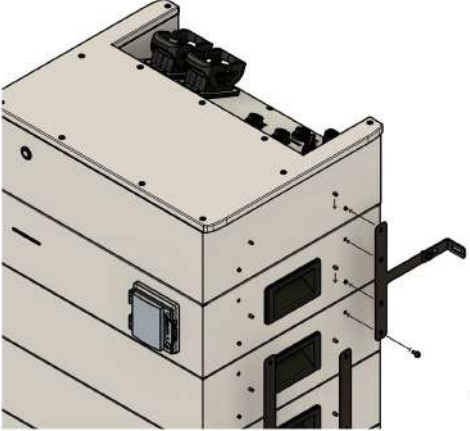



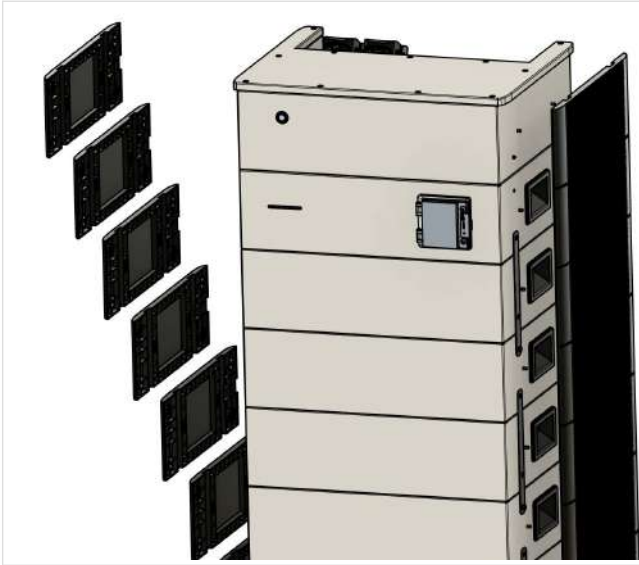
8. Attach the FENECON EMS box to the BMS box.



9. Place the Top box on the second tower.

6.3. Installation — Battery tower on split base

	<p>10. Place the FENECON extension box on the top of all other split sockets.</p>
	<p>11. Fit the T-piece and the bracket with the enclosed M6 bolt.</p>
	<p>12. Hook in the fixing rails of the EMS box and the Top box (wall side) and mark the holes for the wall bracket on the wall.</p> <p>13. Drill the holes and screw the wall bracket to the wall.</p> <p>14. Hook in all other rails alternately left/right one module lower and fasten with the enclosed bolts.</p> <p>15. The arrangement of the mounting brackets shown here is recommended for attaching the battery towers.</p> <div style="border: 1px solid #ccc; padding: 10px; margin-top: 20px;">  <p>See graphic Arrangement of module mounting — Split base for installation details.</p> </div>



16. Attach the side panels of the split base, the battery modules, the BMS box, the EMS box and the Top box.

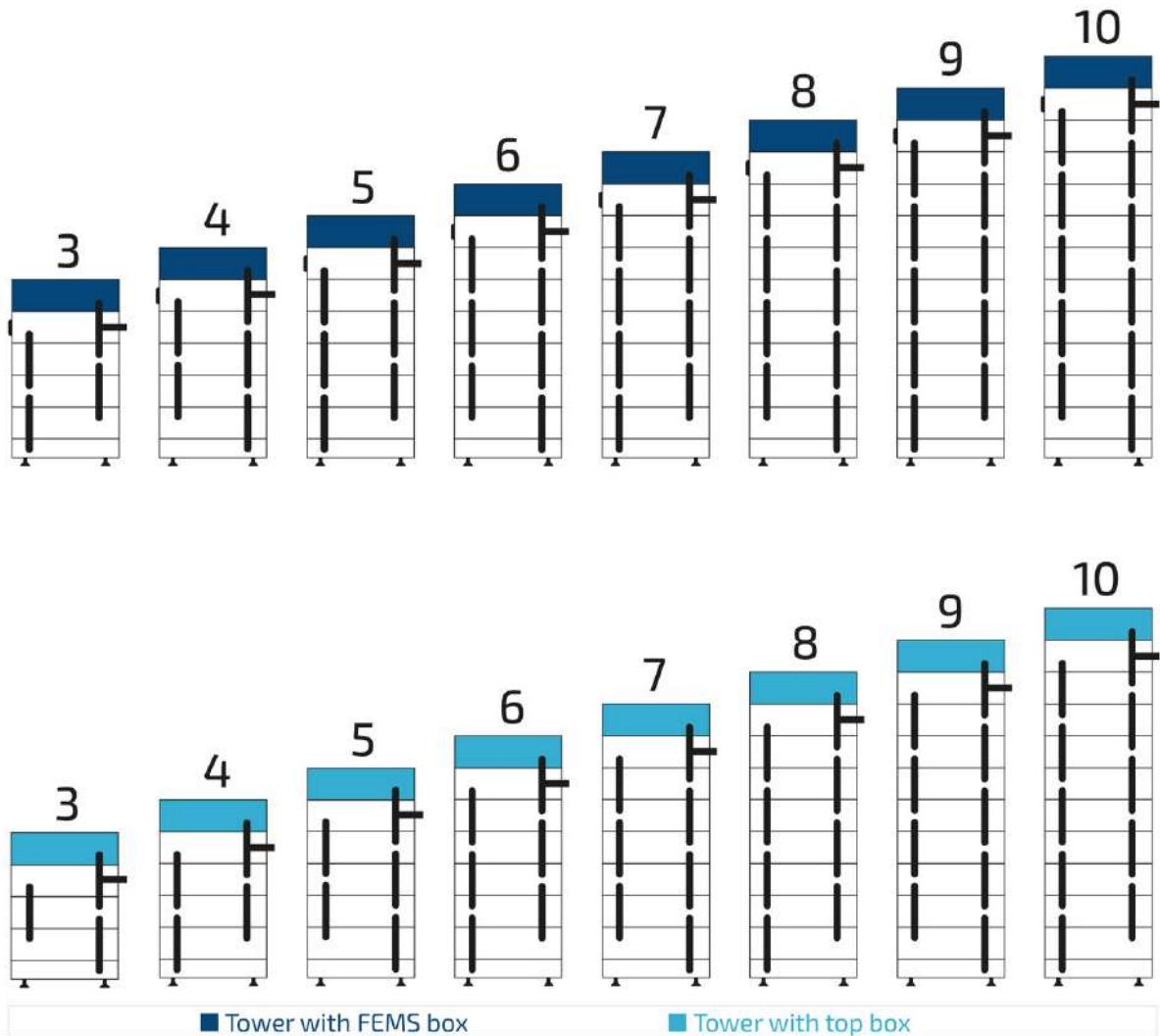


Illustration 23. Module mounting arrangement — Split base

6.4. Electrical installation

6.4. Electrical installation

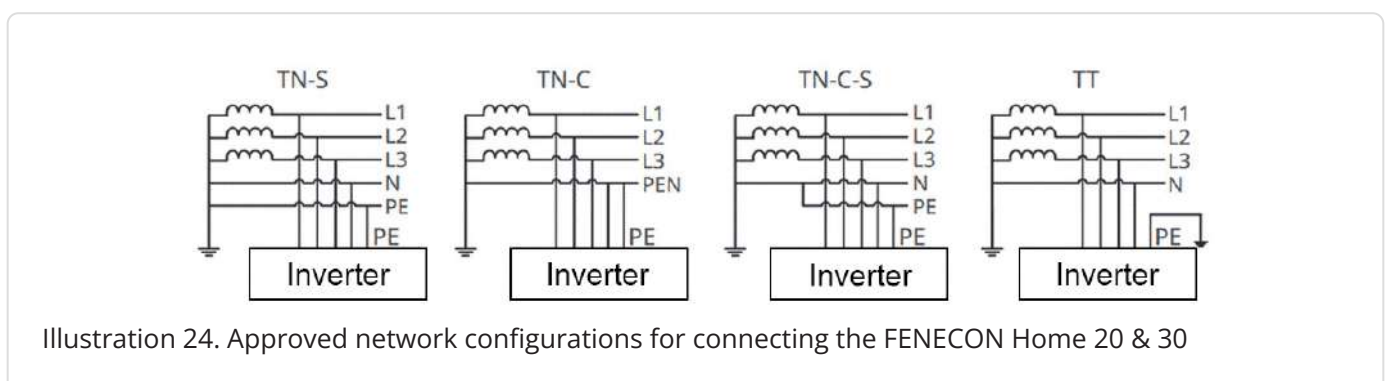
6.4.1. Earthing the inverter and the battery tower

	<ol style="list-style-type: none"> 1. The inverter must be grounded directly to the earth circuit connector. 2. At least a 10 mm² grounding cable must be used. 3. To do this, attach the grounding cable to the inverter at the bottom right using the enclosed screw (red).
	<ol style="list-style-type: none"> 4. The battery tower must be grounded directly to the earth circuit connector. 5. At least a 10 mm² grounding cable must be used. 6. To do this, attach the grounding cable of the EMS box to the grounding bolt (red).
	<ol style="list-style-type: none"> 7. Each additional battery tower (Parallel box or Extension box) must be grounded directly to the earth circuit connector. 8. At least a 10 mm² grounding cable must be used. 9. To do this, attach the grounding cable of the parallel or extension box to the grounding bolt (red).



The cross-section of the earthing must be at least 10 mm².
The inverter and the battery towers must be individually grounded to the equipotential bonding.

6.5. Approved network configurations for connecting the FENECON Home 20 & 30



6.5.1. Connection and wiring of the AC circuit

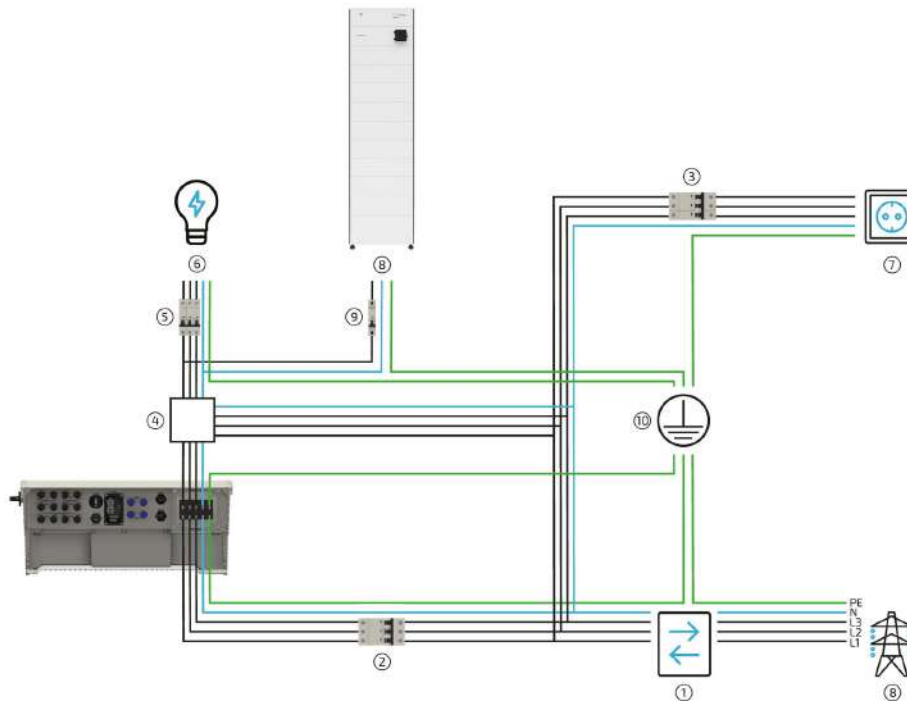


Illustration 25. General information AC connection

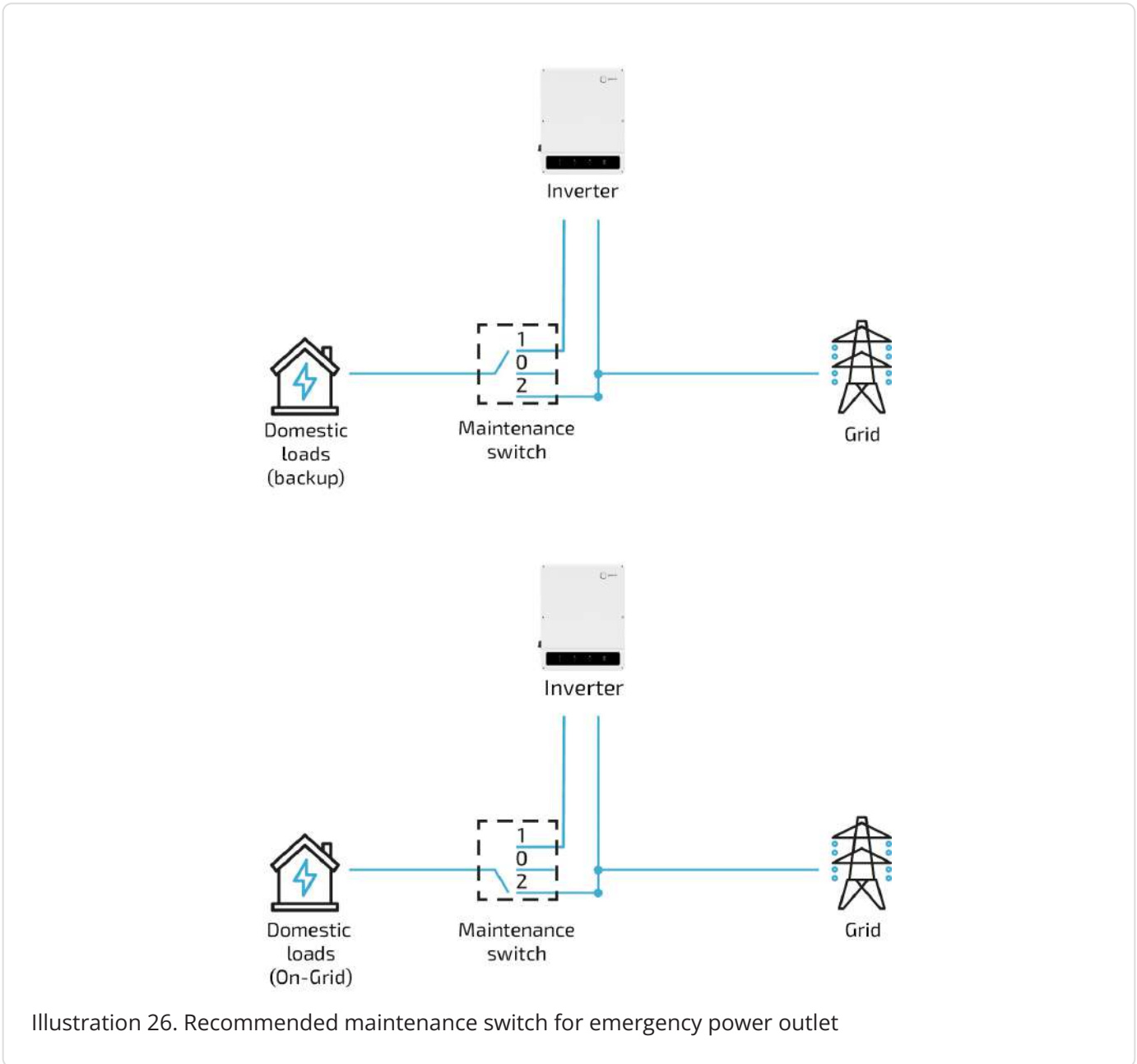
List item	Description
1	Bi-directional meter from energy supplier
2	3-pole inverter fuse protection (20 kW — 40 A; 29.9 kW — 63 A)* ¹
3	Fuse protection of the consumer loads (no emergency power) with RCD type A and suitable MCBs
4	Service switch for switching the emergency power loads to the mains (recommended)
5	Consumer loads protected by suitable MCBs and RCD type A 30 mA * ²
6	Consumer loads — supplied with emergency power maximum 20/30 kW/6.666/9.97 kW per phase (also applies in normal operation if grid is available!); no other AC generators permitted
7	Consumer load not supplied with emergency power
8	AC supply to the EMS box (if consumer loads are connected to the emergency power outlet)
9	Fuse protection maximum C6 or C10 1-pole
10	Earth circuit connector

Table 36. Components for AC connection (not included in the scope of delivery)

*¹ In addition, the currently valid national regulations and the specifications of the relevant grid operator must be observed. (If an RCD is required by the grid operator, an RCD type A with a tripping current of 300 mA is recommended; at 30 mA, unwanted shutdowns may occur.)

6.5. Approved network configurations for connecting the FENECON Home 20 & 30

*²The currently valid national regulations, the specifications of the associated network operator and the manufacturer's specifications must be observed.



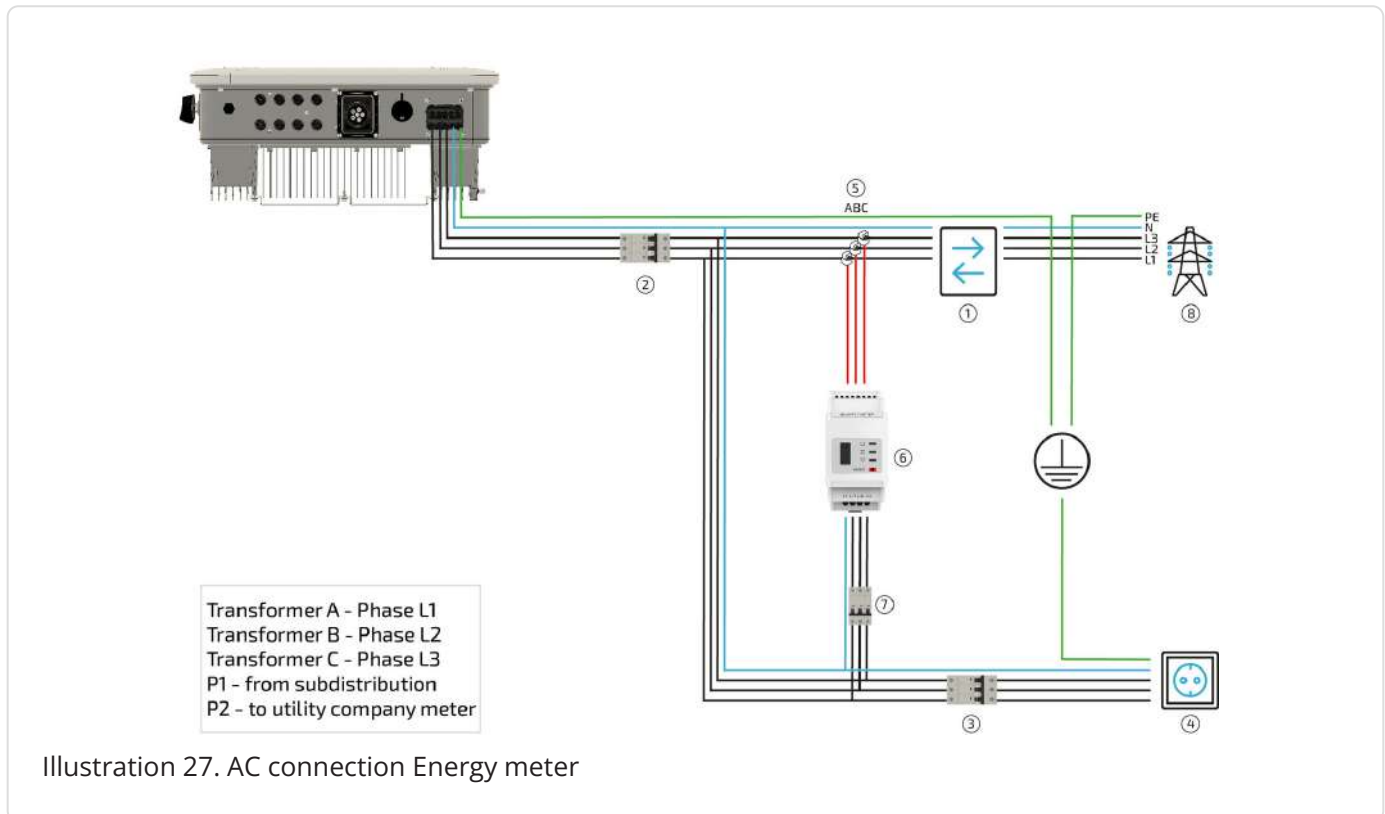
List item	Description
1	Emergency power consumers are supplied with emergency power via inverter (normal position)
2	Emergency power consumers are disconnected from the inverter and grid
3	Emergency power consumers are supplied from the grid

Table 37. Description of the switch positions of the maintenance switch (not included in the scope of delivery)



The automatic emergency power switchover is not affected by the maintenance switch.

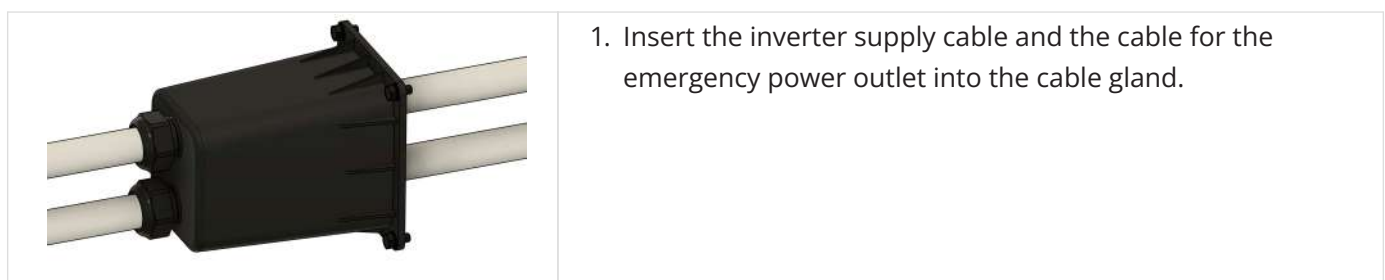
6.5. Approved network configurations for connecting the FENECON Home 20 & 30



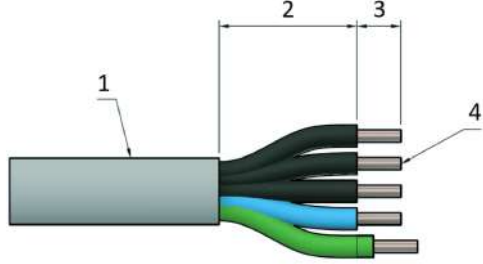




Item	Description
1	2 bi-directional meter from energy supplier
2	Inverter fuse protection C40/C63 3-pole* ¹
3	Consumption fuse (no Back-up Power) with RCD type A and suitable circuit breakers
4	Consumption not supplied with emergency power
5	Folding transformer (directly behind utility meter) already pre-installed on the energy meter
6	Energy meter
7	Fuse for the Energy Meter (recommended) B6 3-pole

Table 38. Components for AC connection

*¹ In addition, the currently valid national regulations and the specifications of the relevant grid operator must be observed. (If an RCD is required by the grid operator, an RCD type A with a tripping current of 300 mA is recommended; at 30 mA, unwanted shutdowns may occur.)



6.5. Approved network configurations for connecting the FENECON Home 20 & 30

	<p>2. Strip the sheath and the cores.</p> <p>3. Make sure that the PE is slightly longer than the other cores.</p> <table border="1" data-bbox="678 321 1489 688"> <thead> <tr> <th>Section</th> <th>Description</th> <th>Dimensions</th> </tr> </thead> <tbody> <tr> <td>1</td> <td>Outer diameter</td> <td>21 to 26 mm</td> </tr> <tr> <td>2</td> <td>Length of stripped cable</td> <td>70 to 80 mm</td> </tr> <tr> <td>3</td> <td>Length of stripped conductor</td> <td>11 to 13 mm</td> </tr> <tr> <td>4</td> <td>Conductor cross-section</td> <td>10 to 16 mm²</td> </tr> </tbody> </table>	Section	Description	Dimensions	1	Outer diameter	21 to 26 mm	2	Length of stripped cable	70 to 80 mm	3	Length of stripped conductor	11 to 13 mm	4	Conductor cross-section	10 to 16 mm ²
Section	Description	Dimensions														
1	Outer diameter	21 to 26 mm														
2	Length of stripped cable	70 to 80 mm														
3	Length of stripped conductor	11 to 13 mm														
4	Conductor cross-section	10 to 16 mm ²														
	<p>4. Press the enclosed cable lugs onto the cores. Alternatively, use other suitable cable lugs. The screw diameter of 5 mm must be observed here.</p>															
	<p>5. Connect the cables to the connections provided (ON-GRID/OFF-GRID). To do this, use the nuts provided and tighten to 2-3 Nm.</p> <p>6. Ensure that a clockwise rotating field is connected.</p> <p>7. Ensure that phase L1 on the inverter and on the energy meter is the same phase; also ensure that this is the case for phases L2 and L3.</p> <p>8. The inverter must be pre-fused with a C40/63 MCB.</p>															
	<p>9. Fasten the cable gland to the inverter. Tighten the bolts with 3 to 4 Nm.</p>															
 <p>K - from subdistribution L - to utility company meter</p>	<p>10. Check the junction box of the split-core CTs.</p> <p>11. Connect the transformer in the sub-distribution board directly behind the grid operator's meter.</p> <p>12. To do this, fold the respective transformer around the phases L1 — L3 and close until the lock audibly engages.</p> <p>13. The cable between the transformer and the energy meter must not be shortened or extended.</p>															

6.5. Approved network configurations for connecting the FENECON Home 20 & 30



The maximum current carrying capacity is 120 A per phase.

K — from the sub-distribution board

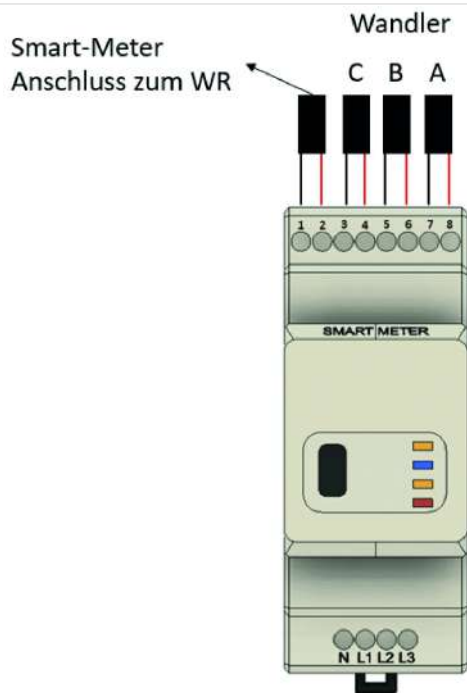
L — to the grid operator's meter (grid connection)

The cable between the transformer and the energy meter must not be shortened or extended.

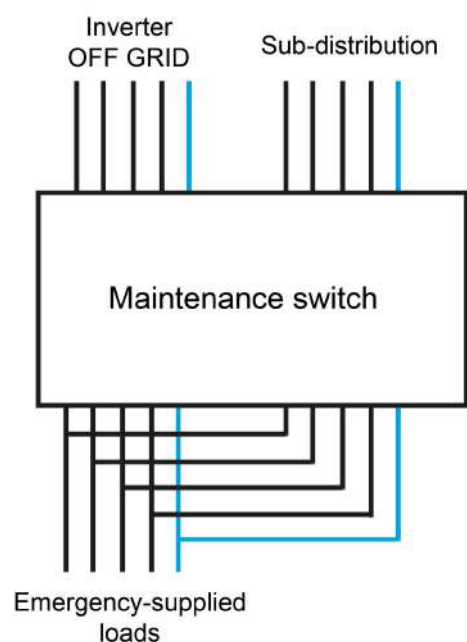
The inside diameter of the hinged cable is 16 mm.

The transformer and meter cannot be replaced by other types.

It must be ensured that phase L1 is also phase L1 on the inverter.



14. Connect the voltage tap to the marked connections on the energy meter.
15. Pre-fuse the energy meter with a B6A breaker for each phase.
16. The split-core CTs are already connected. If the measuring sensors of the smart meter were unscrewed during installation for installation reasons, please ensure that they are reconnected in the correct order.



17. It is recommended that a maintenance switch is installed for the emergency power outlet.
18. In the event of maintenance or failure of the inverter, the emergency power consumers can continue to be supplied via the power grid.



A 4-pole maintenance switch is recommended. Care must be taken to ensure that

6.5. Approved network configurations for connecting the FENECON Home 20 & 30

no neutral displacement can occur during switching. The correct maintenance switch must be selected by a specialist company, taking into account the conditions on site.



This does not affect the function of the automatic emergency power switchover.

6.5. Approved network configurations for connecting the FENECON Home 20 & 30

6.5.2. Synchronize to the grid

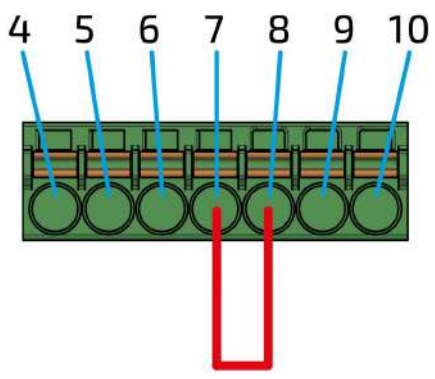
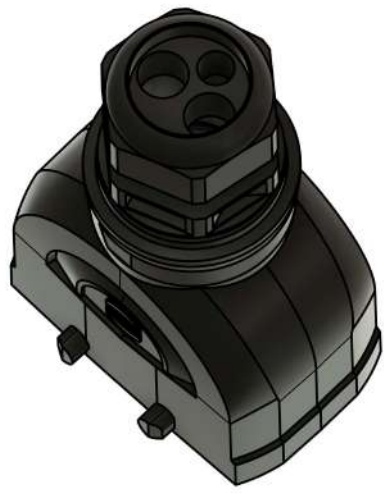

	<ol style="list-style-type: none"> 1. In order for the inverter to synchronize to the grid, a jumper must be connected between pin 7 and pin 8. 2. A core with a cross-section of 0.34 mm² to 0.75 mm² is recommended.
---	--

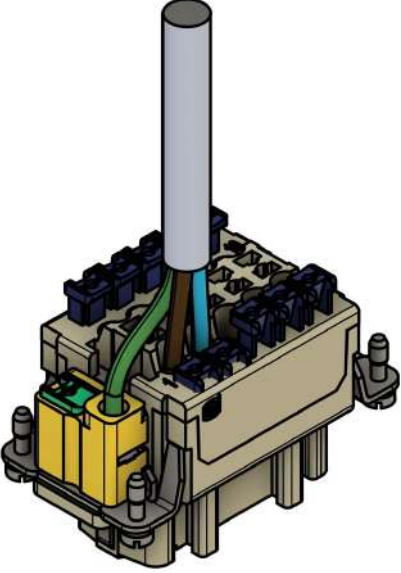


Table 39. Synchronize to the grid — Jumper between pin 7 and 8

6.5.3. AC connection of the FENECON Home 20 & 30-EMS-Box

- An external 230 V power supply is required to supply the FENECON Home 20 & 30 EMS box.
- The purpose of this is to avoid loading the empty battery with additional consumer loads. This can occur particularly in winter when there is no sunshine or when there is snow on the PV system.

	<ol style="list-style-type: none"> 1. Feeding the cable through the smaller hole of the multi-hole seal. A cross-section of 3 x 1.5 mm² is recommended. 2. Make sure that the housing with the 3-hole seal is used. The other housing will be needed later.
	<ol style="list-style-type: none"> 3. Insert the cable through the bolt connection and the multi-hole seal into the Harting housing.

6.5. Approved network configurations for connecting the FENECON Home 20 & 30

	<p>4. Harting socket insert, 10-pin, with cable.</p> <p>Connect L to 1.</p> <p>Connect N to 2.</p> <p>Connect PE to PE.</p>
	<p>5. The other pins are for the integrated relay contacts. If these are not used, the socket can be bolted into the housing.</p> <p>6. Close the remaining feedthroughs of the multi-hole seal with the enclosed filler plugs (10 mm) and tighten the bolt connection.</p>
	<p>7. Connect the plug to the FEMS box.</p> <p>8. Lock the plug at the top and bottom through the holders.</p>

6.6. Explanation of the "zero feed-in" function

6.6. Explanation of the "zero feed-in" function

Connection and operation of electrical energy storage systems on the low-voltage grid in accordance with VDE-FNN Note 07/2024 — Requirements for the energy flow direction sensor EnFluRi (section 4.3) and zero feed-in (section 4.4).

FENECON GmbH hereby declares that the inverters listed in the following table in combination with the respective energy meters specified fulfill the above requirements:

Inverter	Description	Internal Energy Meter	Home Energy Meter (FHM-120-C)*	3-phase sensor without current transformer at the grid connection point (FHM-C)**
Home 6	FINV-6-2-DAH	✓	✓ (optional)	✗
Home 10 (Gen. 1)	FHI-10-DAH	✗	✓	✗
Home 10 (Gen. 1)	FHI-10-DAH 16A	✗	✓	✗
Home 10	FINV-10-2-DAH	✓	✓ (optional)	✗
Home 15	FINV-15-2-DAH	✓	✓ (optional)	✗
Home 20	FHI-20-DAH	✗	✓	✓ (optional)
Home 30	FHI-29,9-DAH	✗	✓	✓ (optional)
Commercial 50 (Gen. 3)	FINV-50-1-DAH	✗	✗	✓
Commercial 100	FINV-100-1-DAH	✗	✗	✓

*Item no.: FHO055

**Item no.: FEH040

6.6.1. Configuration for zero feed-in via the FENECON Energy Management System

The inverters listed above can be configured via the FENECON Energy Management System so that the PV energy generated is used entirely by the user and is not fed-in to the public grid.

To do this, the **Maximum feed-in power** setting in the commissioning wizard must be set to **0 watts**.

6.6.2. Notes on the zero feed-in function:

- If FENECON inverters are used, deviations of < 1 % per phase may occur.
- The accuracy of the zero feed-in depends on the power factor of the connected consumer loads.
- A high proportion of reactive power, especially in the form of harmonics, can negatively affect the accuracy of the active power measurement.

- With zero feed-in, devices that regulate to PV surplus no longer work, as there is no longer a grid feed-in to which they can regulate.

6.6.3. Validity of the declaration:

This declaration applies to all identical inverters. It loses its validity if:

- changes have been made to the device,
- the connection is made improperly,
- the installation was not carried out in accordance with the installation and service instructions,
or
- the inverter is operated with an external generator.

6.6. Explanation of the "zero feed-in" function

6.6.4. DC cable from the battery tower to the inverter

This section can be skipped if there are several battery towers.



You will find the installation instructions for 2 or 3 battery towers in the section [Electrical installation of additional battery towers](#).



1. Use the enclosed DC cable (3 m) for the connection between battery tower and inverter.
2. Connect the cables to the battery (BAT OUT) and to the inverter (BAT1).
3. Connect plus (+) to plus (+) and minus (-) to minus (-).
4. If the DC cables supplied are not long enough, please contact your sales partner.


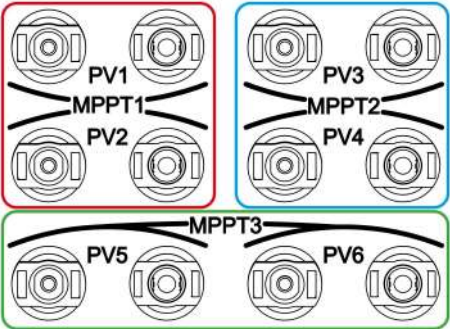


The DC plugs used on the battery side are not compatible with commercially available MC4 plugs.



The 29.9 kW variant has two battery inputs. The FENECON Home 20 & 30 battery tower must always be connected to battery 1 (BAT1).

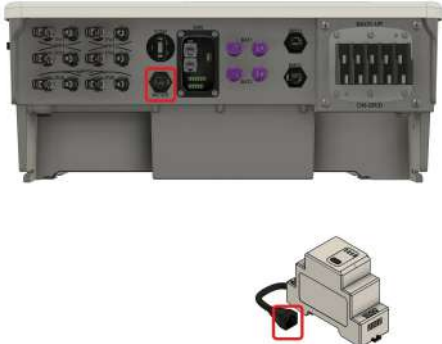
6.6.5. Connection and cabling of PV system

	<p>The various PV strings can be connected directly to the PV inputs on the inverter.</p>
	<p>The 20 kW variant has 2 MPPTs, each with two inputs (red; blue). The 29.9 kW variant has 3 MPPTs, each with two inputs (red; blue; green)</p>





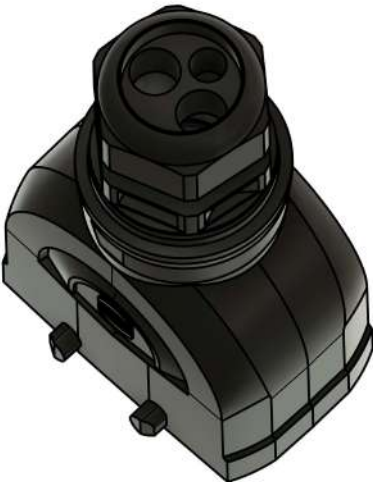

Type 2 overvoltage protection is integrated in the inverter.

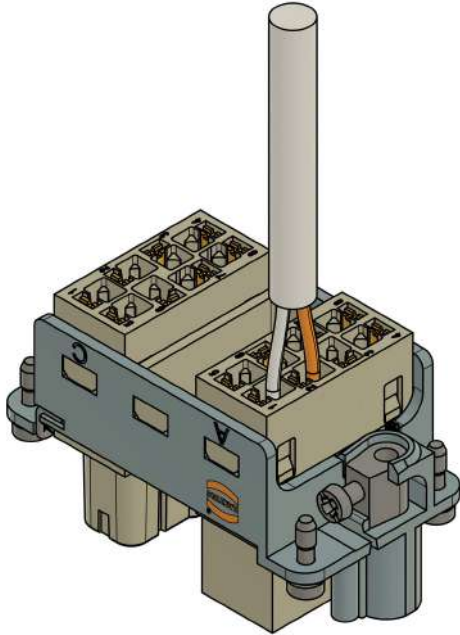
6.6.6. Connecting the smart meter to the inverter

	<p>Connect the enclosed cable for the meter to the bayonet connection side of the inverter and lock it. Connect the other end to the meter. If the existing 10 m cable is not sufficient, it can be extended up to 100 m using a conventional network cable.</p>
---	--

6.6. Explanation of the "zero feed-in" function

6.6.7. Communication between inverter and EMS box

	<ol style="list-style-type: none"> 1. Feed the enclosed communication cable (3 m network cable with open end) through one of the holes in the multi-hole seal of the communication port cover. 2. Leave the other openings of the multi-hole seal closed.
	<ol style="list-style-type: none"> 3. Connect the plug of the communication cable to the inverter.
	<ol style="list-style-type: none"> 4. Connecting the cover to the inverter and tightening the bolt connection.
	<ol style="list-style-type: none"> 5. Feeding the cable through one of the four holes in the multi-hole seal.
	<ol style="list-style-type: none"> 6. Insert the cable through the bolt connection and the multi-hole seal into the Harting housing.

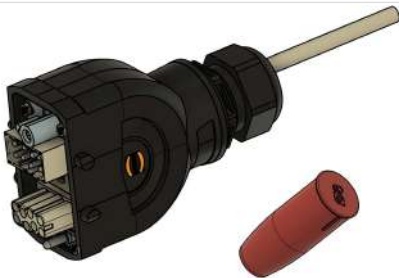


7. The other end with two open pins must be connected to terminal 1/2 on the Harting plug (16-pin — A).
8. Connect the white core to terminal 1.
9. Connect the orange core to terminal 2.



If controllable consumer loads have been installed and one of the following FEMS extensions has been purchased, the following two steps can be neglected for the time being.

- FEMS App Heat pump "SG-Ready"
- FEMS App CHP




10. Then screw the socket into the Harting housing.
11. Close the other openings in the bolt connection with the enclosed filler plugs (8 mm).
12. Provide strain relief for the cable by tightening the bolt connection.



13. Close the remaining feedthroughs of the multi-hole seal with the enclosed filler plugs (8 mm) and tighten the bolt connection.
14. Lock the plug at the top and bottom through the brackets.

6.6. Explanation of the "zero feed-in" function

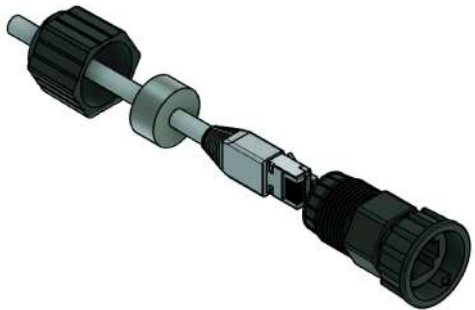
6.6.8. Communication from a battery tower

	<p>If only one battery tower is installed, the jumper plug (included in the scope of delivery) must be plugged into the PARALLEL OUT connection and locked by turning the underside.</p>
---	--



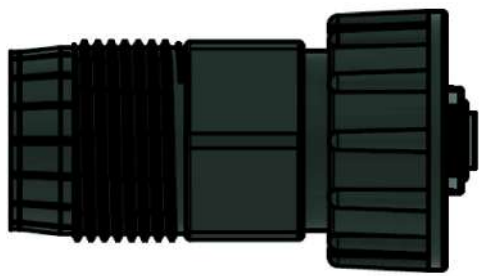

You will find the assembly instructions for 2 or 3 battery towers in the section [Communication of additional battery towers].

6.6.9. Communication with the customer network

	<ol style="list-style-type: none"> 1. To seal the network connections, insert the cable into the connector and bolt it in place. Only the multi-hole seal and the bolt connection are required.
--	--




If the battery tower is installed indoors, this point can be skipped and the network cable can be connected directly.

	<ol style="list-style-type: none"> 2. Make sure that the network connector protrudes approx. 3 mm above the bayonet catch at the front. 3. For example, the jumper plug of the battery can serve as a reference for the position of the network connector.
	<ol style="list-style-type: none"> 4. For internet connection and system configuration, connect the network cable to the LAN port of the battery and the other end of the cable to the customer's network.



The electrical energy storage system does not have a WiFi function.

6.6.10. Cover for the internal input (optional)

	<p>Optionally, a network connector housing with filler plug (included in the scope of delivery) can be used as a cover for the internal connection. The network connector housing and the filler plug must be fitted beforehand.</p>
---	--



An IP classification is only guaranteed if the corresponding plugs are locked on all connections.

7. Parallel connection of several battery towers

7. Parallel connection of several battery towers

7.1. Assembly of further battery towers

7.1.1. Assembly of battery tower 2 with FENECON Home 20 & 30 Parallel box

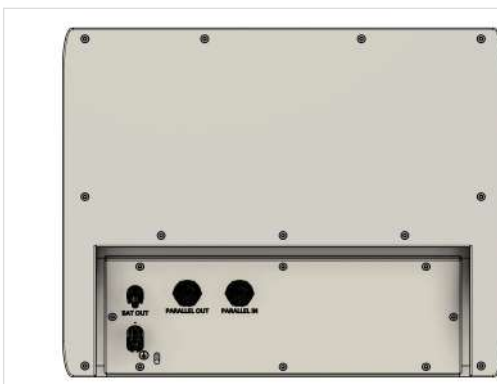
If a second battery tower is available, the Parallel box is plugged onto the second battery tower instead of the EMS box.



To do this, repeat the steps from the section [Assembly battery tower 1](#). In step 8, attach the FENECON Home 20 & 30 parallel box instead of the FENECON Home 20 & 30 EMS box.

7.1.2. Assembly of battery tower 3 to 4 with FENECON Home 20 & 30 extension box

If there is a third to fourth battery tower, an Extension box is attached to the third to fourth battery tower instead of the EMS box.



To do this, repeat the steps from the section [Assembly battery tower 1](#). In step 8, attach the FENECON Home 20 & 30 extension box instead of the FENECON Home 20 & 30 EMS box.

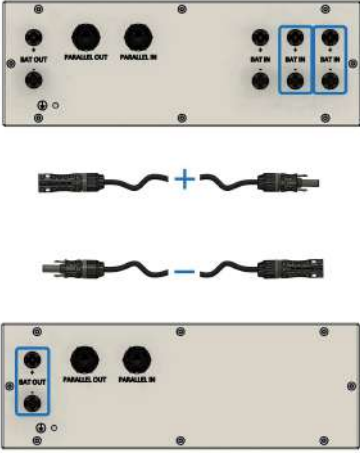
7.2. Electrical installation of additional battery towers

7.2.1. DC cable between two battery towers and the Inverter

1. Use the enclosed DC cable (3 m) for the compound from the second battery tower with the plugged-on Parallel box to the inverter.
2. If the length of the DC battery cable is not sufficient, extend it using one of the enclosed sets of DC cables (2 m).
3. Connect the cables to the second battery tower (Parallel box) (BAT OUT) and the inverter (BAT) (red).
4. Connect plus (+) to plus (+) and minus (-) to minus (-).
5. The two battery towers are connected to each other using the second set of cables supplied in the Parallel box.
6. To do this, connect the two cables to the first battery (EMS box) (BAT OUT) and to the second battery (Parallel box) (BAT IN) (green).

7.2. Electrical installation of additional battery towers

7.2.2. DC cable between the third to fourth battery tower and Parallel box



1. The third and fourth battery towers are connected to the Parallel box. Depending on the distance, a 2 m cable set is sufficient; if not, the two enclosed cable sets can be compounded and thus extended to 4 m.
2. To do this, connect the two cables between the Extension box (BAT OUT) and the parallel switch box (BAT IN).

7.3. Communication of further battery towers

7.3.1. Communication between two to four battery towers

The diagram illustrates the connection of network cables between battery towers. It shows four towers with their respective ports highlighted in different colors: green, blue, orange, and red. A network cable with a red jumper plug is shown connecting the PARALLEL OUT of one tower to the PARALLEL IN of the next.

1. If several battery towers are operated in parallel, the network cable supplied with the Parallel box and Extension box must be used between the towers (green).
2. The network cable must be plugged in and locked between the EMS box (PARALLEL OUT) and the Parallel box (PARALLEL IN).
3. Likewise on all other towers, always between PARALLEL OUT and PARALLEL IN (blue/orange).
4. At the last tower, plug the jumper plug into PARALLEL OUT (red).

8. Initial commissioning

8. Initial commissioning

8.1. Checking the installation, connections and cabling

Check the system as follows before initial commissioning:

- All components (clearances, environment, mounting) are installed correctly.
- All internal wiring is complete and properly connected.
- All external supply lines (power supply, communication cable) are properly connected.
- All connected loads are matched to the system and the necessary settings have been made.
- All necessary tests of the system were carried out in accordance with the standards.



Commissioning must only be carried out by trained specialist personnel.

- It is forbidden to disconnect the electrical connectors while they are live. Disconnect the power supply.
- Batteries must not be connected or disconnected when a current is flowing.
- Opening batteries is prohibited.



- Before commissioning the system, ensure that the battery modules are not deeply discharged.
- If the battery modules are deeply discharged, contact FENECON Service
- Only charge deeply discharged battery modules as instructed by the FENECON Service.

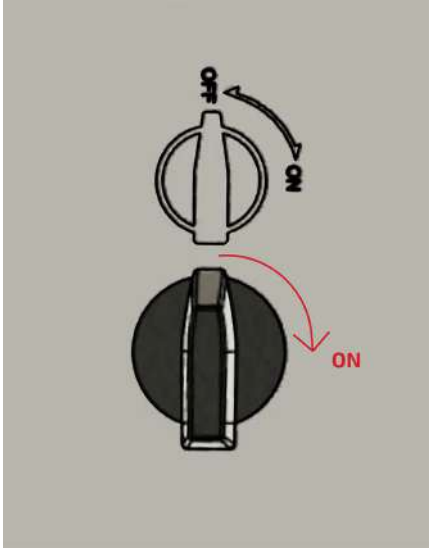
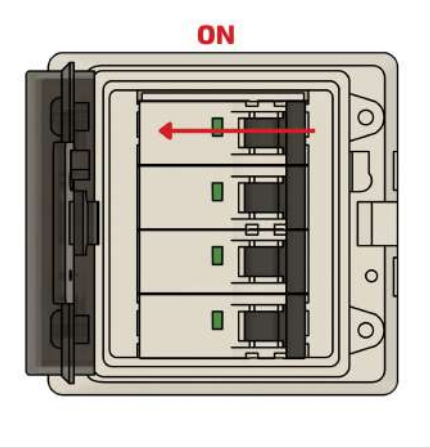
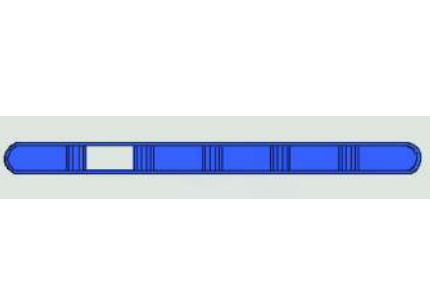
This is indicated in the installation and service instructions:



- that an appropriate cooling down period must be observed before starting work on the devices,
- or that the risk of burns is prevented by wearing suitable protective gloves.

8.2. Switching the system on/off

8.2.1. Switching on the system

	<ol style="list-style-type: none"> 1. Rack in the EMS box (sub-distribution board or socket). 2. Rack in the inverter (sub-distribution board, grid and emergency power side). 3. If available, switch on the PV system with the DC switch on the inverter (left side of the inverter).
	<ol style="list-style-type: none"> 4. Racking in the battery tower (front battery tower). 5. If there are several battery towers, all towers must be racked in.
	<ol style="list-style-type: none"> 6. If commissioning has already been completed, the battery will start and the LED bar should flash after approx. 60 seconds. 7. The system is now ready for use. 8. If commissioning has not yet been completed, the battery will not start. Configuration via commissioning wizard.



The system is restarted by pressing the push-button on the front of the EMS box. Restarting the system can take up to three minutes.



If the system has not yet been configured, the battery goes into error mode or switches off. This can also happen during configuration. It is therefore recommended that you only switch on the battery when you are prompted to do so during the configuration process.

8.2. Switching the system on/off

The inverter only starts after configuration and only then synchronizes with the grid.

8.2.2. FEMS push-button and LED ring


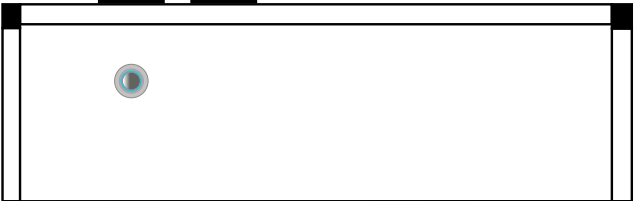
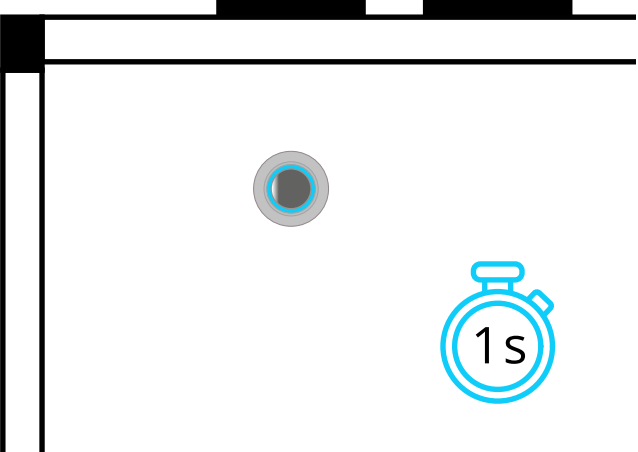
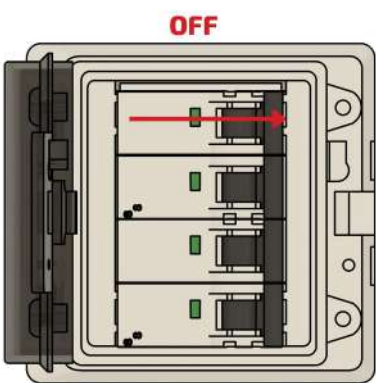
	<p>If the blue LED ring of the push-button does not light up, the FEMS box is not supplied with power or the FEMS box is switched off.</p>
	<p>If there is an internet connection to the FENECON server, the blue LED ring of the push-button lights up permanently.</p>
	<p>If the blue LED ring of the push-button flashes with an interval of 1 second, there is no internet connection to the FENECON server.</p>

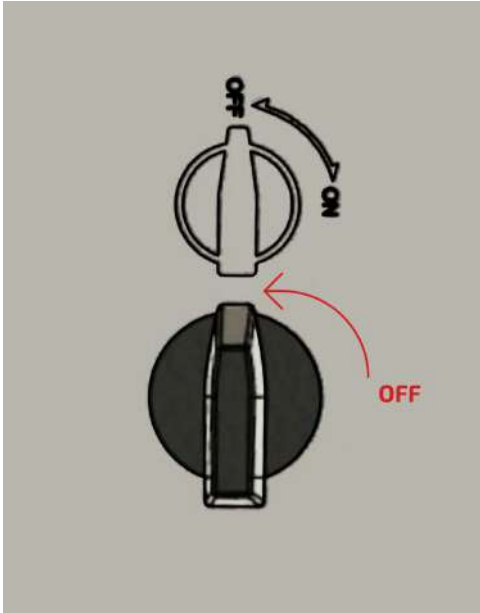
Table 40. Status of the LED ring on the FEMS box



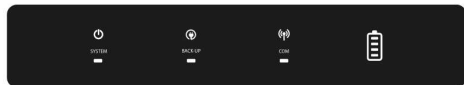
Pressing the push-button restarts the FEMS.

8.2.3. Switching off

	<ol style="list-style-type: none"> 1. Racking out the battery tower (front battery tower). 2. If there are several battery towers, all towers must be fused.
---	--



3. If present, switch off the PV system using the DC switch on the inverter.
4. Rack out the inverter. (sub-distribution board, grid and emergency power side).
5. Rack out the EMS box (sub-distribution board, or socket).



6. The system is only completely switched off when all LEDs on the inverter and the battery are no longer lit. This can take approx. 30 seconds.
7. The inverter remains on if one of the three energy sources is not switched off.

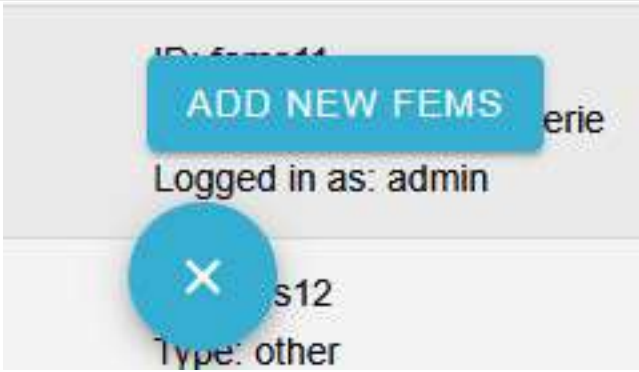



8.3. Configuration via commissioning wizard



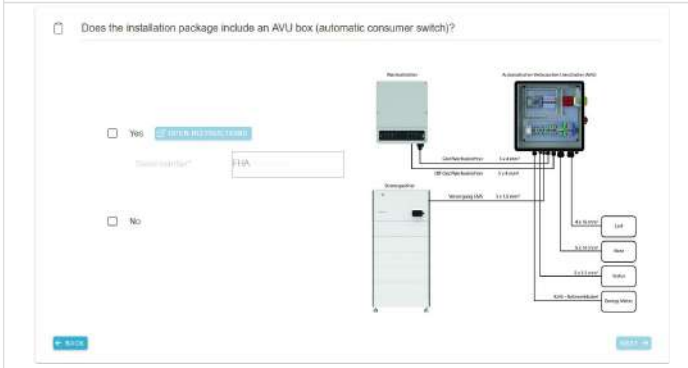

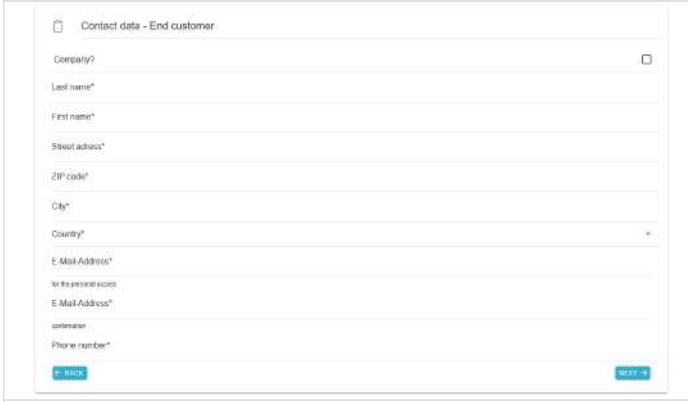

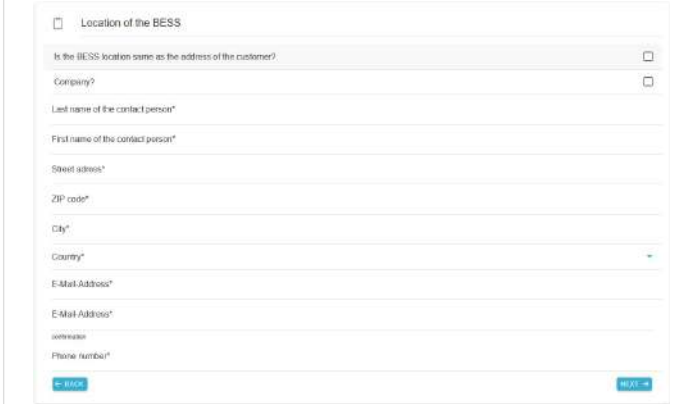
8.3. Configuration via commissioning wizard

Open www.fenecon.de and click on the login to FENECON Online Monitoring "FEMS-Login" in the top right-hand corner. Alternatively, you can use the QR code below or the link to access the page.









	<p>1. https://portal.fenecon.de</p>
---	---

If you do not yet have an installer account, [learn how to create one here](#).

	<p>After logging in, you will be taken to this screen. Click on the plus symbol at the bottom center and then on <i>ADD NEW FEMS</i>. TIP: If you cannot access this screen directly, please click on the ☰ burger menu at the top left and then on <i>All systems</i>.</p>
	<p>1. Enter the installer key. You can find this on the sticker on the inverter or on the FEMS box.</p>
	<p>2. Carry out a software update if necessary.</p>
	<p>3. Select the attachment type, in this case: FENECON Home.</p>

	<p>4. Select the system.</p> <div style="border: 1px solid gray; padding: 10px; margin-top: 20px;">  <p>The product names are based on the output of the respective inverter.</p> </div>
	<p>5. If it is a system with a 6 kW or 10 kW inverter, select here whether an automatic off-grid switch is installed. If yes, the serial number must be entered here manually.</p>
	<p>6. The contact details of the installer account are automatically transferred.</p>
	<p>7. Enter the end customer's contact details here.</p> <div style="border: 1px solid gray; padding: 10px; margin-top: 20px;">  <p>The end customer account is created with the e-mail address entered here. The end customer commissioning report is also sent to this address. Both the installer and the end customer will receive a commissioning report by email.</p> </div>
	<p>8. Enter the location of the storage system here if the system location differs from the customer address (for service purposes).</p>

8.3. Configuration via commissioning wizard

	<p>9. Click on <i>VALIDATE</i>.</p> <p>Then select the address found from the list.</p> <div style="border: 1px solid gray; padding: 10px; margin-top: 10px;">  <p>The location coordinates are checked here to ensure the functions of location-dependent applications (e. g. weather data).</p> </div>
	<p>10. If dimming is required at the system location in accordance with § 14a EnWG, you can set this here.</p>
	<p>11. This is where you activate the emergency power function and, if necessary, the emergency power reserve.</p> <div style="border: 1px solid gray; padding: 10px; margin-top: 10px;">  <p>The emergency power reserve can be configured by the end customer at any time afterwards. However, the general emergency power function CANNOT.</p> </div>
	<p>12. Select the energy flow direction meter ("EnFluRi") here:</p> <p>For Home 6, 10 & 15: Here you can select whether the internal one built into the inverter (standard) is selected, or whether the "small" energy meter is selected if the application requires cables longer than 15 meters. Optional accessories can also be selected here.</p> <p>Explicitly for Home 20 & 30: The standard scope of delivery <i>or</i> the optionally available, FENECON meter for higher currents is selected here.</p>
	<p>13. Select the pre-fuse of the house connection meter here.</p> <p>Specified in amperes (A).</p>
	<p>14. The connections of the MPP trackers are displayed here for checking purposes. Check whether the connections of the MPPT used have been made correctly and confirm that the connections have been checked.</p>

	<p>15. Configure shade management according to MPP trackers here.</p> <div style="border: 1px solid #ccc; padding: 10px; margin-top: 10px;"> <p>If PV optimizers are used, shade management must be switched off.</p> </div>
	<p>16. Configure Feed-in management according to the grid operator's specifications.</p>
	<p>17. Check the information you have previously entered and confirm the terms and conditions and warranty conditions.</p> <p style="text-align: center;">The battery and inverter must also be switched on.</p>
	<p>18. After clicking on START CONFIGURATION the configuration of the system begins.</p> <div style="border: 1px solid #ccc; padding: 10px; margin-top: 10px;"> <p>Leave the battery and inverter switched on during the entire configuration process.</p> </div>
	<p>19. Select the number of battery towers and modules.</p> <p style="text-align: center;">Confirm the displayed serial numbers of the system components.</p> <p style="text-align: center;">The readout may take a few minutes.</p> <div style="border: 1px solid #ccc; padding: 10px; margin-top: 10px;"> <p>In rare cases, serial numbers must be added manually.</p> </div>
	<p>20. This completes the configuration via the commissioning wizard.</p> <p style="text-align: center;">The system is now ready for operation.</p> <p style="text-align: center;">You can now continue with the installation of FEMS Apps by clicking on APP CENTER.</p>

8.3. Configuration via commissioning wizard



- You will receive an e-mail with a commissioning report attached for your records.
- The customer also receives an e-mail with the personal access data for end customer monitoring.

9. FEMS Online Monitoring

The FEMS Online Monitoring is used to visualize all energy flows in your system. The Energy Monitor shows live data on grid withdrawal or feed-in, PV production, charging/discharging of the battery energy storage system and power consumption. Other widgets show the percentage of self-sufficiency and Self-consumption. In addition, the individual widgets offer a detailed view, which can also be used to view the performance values with phase accuracy.

In addition to the pure information display, all additionally purchased FEMS extensions, such as for integrating a heat pump, Heating element, combined heat and power plant (CHP), are also listed in Online Monitoring. Their functionality can be controlled via the corresponding widget.

In addition to the live view, the history offers the option of selecting self-selected time periods for Online Monitoring. The status of the entire system and the individual components can be monitored at any time using the info symbol.

9.1. Access data

Access to FEMS Online Monitoring is separated according to end customer and installer.

9.1.1. Access for the end customer

Access for the end customer is automatically generated once commissioning is complete and sent to the end customer by e-mail.

The terms and conditions still need to be confirmed here, then the monitoring is available without restrictions.

If additional users want to access the system, they must create their own user account. This is done as described in the section [Configuration via commissioning wizard](#), but here "USER" must be selected in the header.

After successfully creating an additional user account, all we need is an email to service@fenecon.de with the email address used and the FEMS number concerned, we will create the link and other users can use the Online Monitoring of a system.

9.1.2. Access for the installer

The installer account can be created as described in the section [Configuration via commissioning wizard](#) on the FENECON homepage. Access is required for successful commissioning.

10. Capacity expansion of the system

10. Capacity expansion of the system

The capacity can also be expanded at a later date; there is no time limit here.

The maximum capacity is not reached with additional new battery modules, as new modules are equal to the old modules.


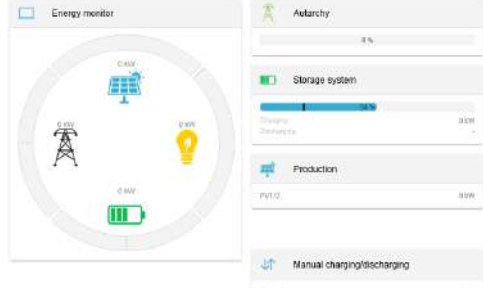

10.1. Capacity expansion of the battery tower by one or more battery modules

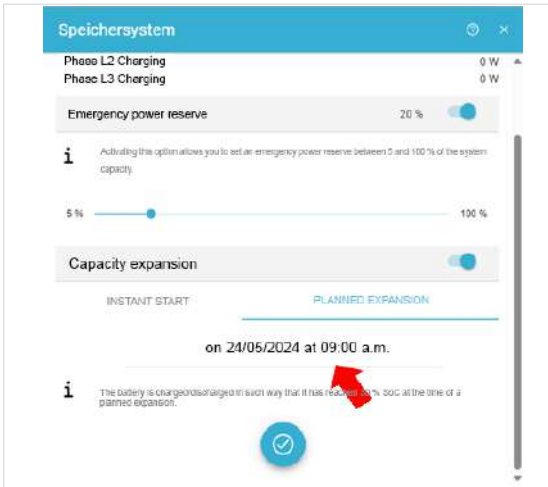
The battery tower can be expanded to up to 15 battery modules in one battery tower.

If the electrical energy storage system is expanded with additional battery modules after commissioning, proceed as follows:



After a capacity expansion, the commissioning wizard must be carried out again.

	<ol style="list-style-type: none"> 1. Open the Online Monitoring. 2. In order for the new modules to synchronize faster with the existing modules, an equal state of charge is required (30 % SoC). The electrical energy storage system automatically prepares itself if the state of charge does not have the same SoC.
	<ol style="list-style-type: none"> 3. Click on the "Electrical energy storage system" widget in Online Monitoring.
	<ol style="list-style-type: none"> 4. Activate the "Capacity expansion" function in Online Monitoring under Electrical energy storage system. The "Capacity expansion" is activated when the blue bar is displayed. 5. You can now choose between "Immediate start" and "Planned extension". With the two options, the battery is charged or discharged to 30 %. 6. When the state of charge is reached, charging/discharging is stopped and the charge level of 30 % is maintained.



7. If you select "Planned extension", you can specify the planned day and time. In this example, 24.05.2024 and the time of 09:00 were selected. At this time, the battery is expected to be charged or discharged to reach 30 % for the "Planned extension".



8. You must then confirm your desired settings by clicking on the blue tick. The desired extension will be saved and, depending on the option selected, implemented immediately or later at a specific time.

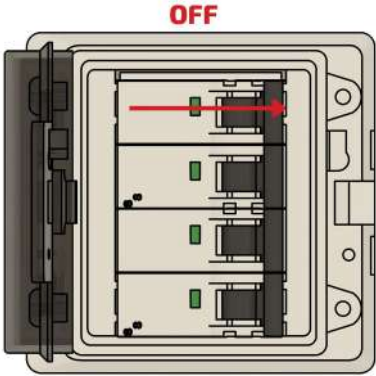



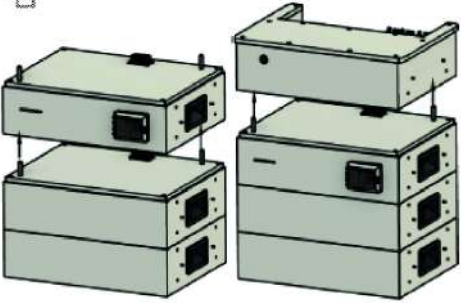

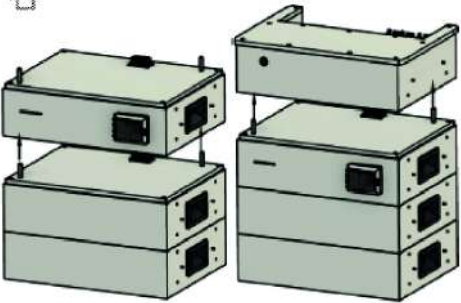
9. Then run the commissioning wizard again.

10.1. Capacity expansion of the battery tower by one or more battery modules

The capacity can also be extended at a later date; there is no time limit here. You will not reach the full capacity with the new battery module, as the new module will equalize with the old modules.

If the battery tower is extended by additional battery modules after several weeks or months, the following procedure must be followed:

<p>29-30 % SoC</p>	<ol style="list-style-type: none"> 1. Charge/discharge the system to a charge level of 29-30 %; then switch off.
	<ol style="list-style-type: none"> 2. Switch off the entire system. The exact procedure is described in the section Switching off. Set the battery fuse switch to OFF. DC switch of the inverter to OFF. AC fuse on the grid and emergency power side to OFF.
	<ol style="list-style-type: none"> 3. Remove the top three side panels on each side. 4. Remove the latch up to the first battery module on both sides.

	<p>5. Remove the FEMS box and BMS box and place them on their side. To do this, screw the wall bracket of the BMS box from the wall.</p>
	<p>6. Attach new battery module.</p>
	<p>7. Proceed as described in section [Assembly — Battery tower 1 with FEMS box], step 8.</p> <ul style="list-style-type: none"> Attach the FENECON BMS box. Attach the FEMS box. Attach the locks. Attach the side covers.



- If the exact voltage value of the old and new battery modules has not been matched, SoC jumps will occur when the battery is charged and discharged. This means that the full capacity is temporarily not available.
- The greater the voltage difference between the "old" and "new" batteries, the longer it can take until there are no more SoC jumps and the full capacity is available.

10.2. Capacity expansion of the system by one or more battery towers

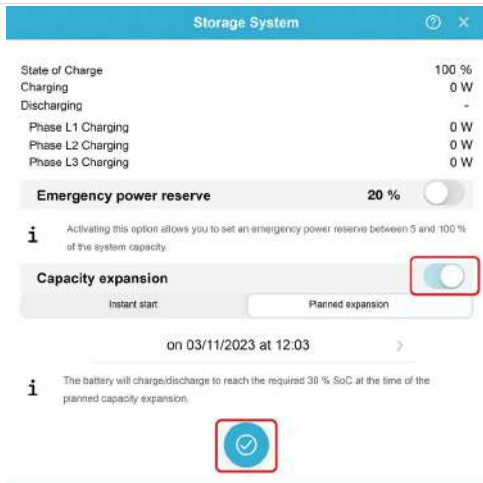
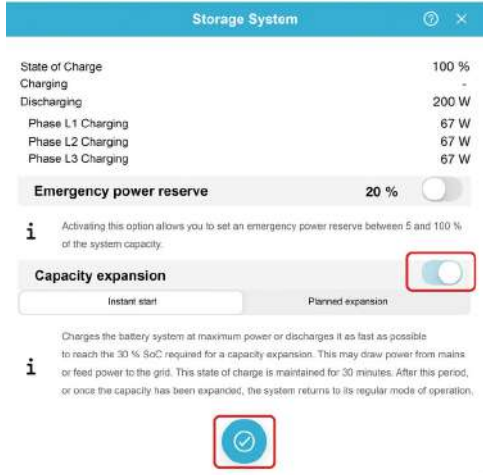
10.2. Capacity expansion of the system by one or more battery towers

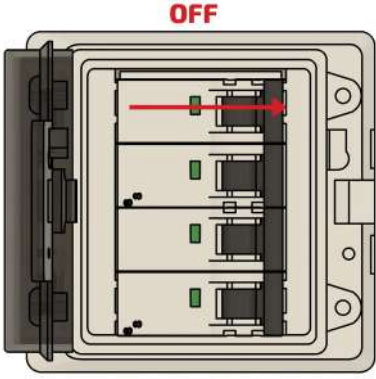



The capacity of the system can be subsequently expanded by one or more battery towers with the same capacity. There is no time limit here.

The maximum expansion of the FENECON Home 20 & 30 system comprises up to 4 battery towers, each with 4 to 15 battery modules and a maximum of 168 kWh.

The full capacity is not achieved with new battery modules, as the new modules become similar to the old modules.

Proceed as follows before the extension:

	<ol style="list-style-type: none"> 1. Activate the "Capacity expansion" function in Online Monitoring under Electrical energy storage system. 2. The battery is charged/discharged to 30 %. When the state of charge is reached, charging/discharging is stopped and the charge level is maintained.
	

	<p>3. Switch off the entire system. The exact procedure is described in detail in the section Switching off. Fuse switch of the battery to OFF. AC fuse of the inverter to OFF.</p>
	<p>4. Assembly of the new battery towers as described from section Assembly — Battery tower 1 with FEMS box and section Initial commissioning. 5. Everything can then be switched on again as described in the Switching on the system section.</p>
<p> Enter installer key</p> <div style="border: 1px solid gray; padding: 5px; width: fit-content; margin: 10px auto;">XXXX-XXXX-XXXX-XXXX</div> 	<p>6. Run the commissioning wizard again.</p>



- If the exact voltage value of the old and new battery towers has not been matched, the new batteries will not be connected.
- This is not displayed as an error, but it can happen that the SoC displays of the individual battery towers show different charge levels.
- When the charge levels have equalized after a charging cycle, the last battery towers also switch on.
- The battery towers work independently, so the flashing frequency of the

10.2. Capacity expansion of the system by one or more battery towers

different towers may vary. The SoC display of the individual towers may also differ briefly.

11. FEMS extensions

For the following FEMS extensions, the integrated relays can be used directly on the (first) battery tower.

Various pins on the Harting plugs are provided for this purpose.

- Harting plug 10-pin: 3 x free relay channels (max.: 230 V; 10 A)
- Harting plug 16-pin: 2 x control contacts (max.: 24 V; 1 A)
 - 3 x digital input
 - 1 x digital input for § 14a
 - 1 x analog output (0-10 V)

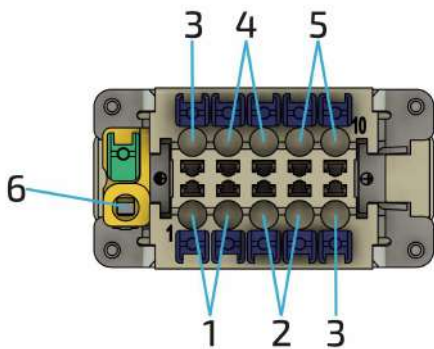
It may not be possible to connect and operate all apps at the same time. For more information on the following apps, please visit our homepage.



<https://www.fenecon.de/fems-apps/>



If the integrated relays are not sufficient, an external 8-channel relay board can be connected via Ethernet.

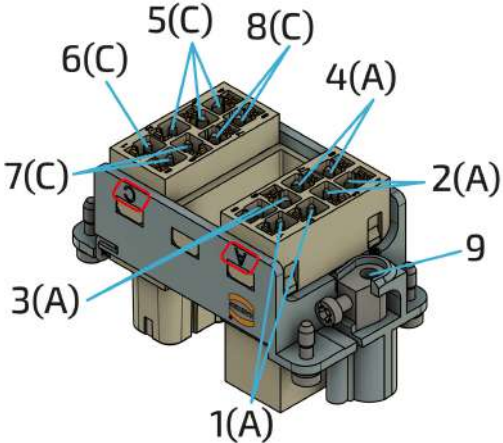


The pin assignment of the Harting plug (10-pin) is shown in detail below.

Item	Description
1	230 V supply for internal components
2	Relay 1 (230 V; 10 A)
3	Relay 2 (230 V; 10 A)
4	Relay 3 (230 V; 10 A)
5	Neutral conductor connection (required for integrated meter)
6	PE connection

11. FEMS extensions

Table 41. Connector — Pin assignment — Power connector

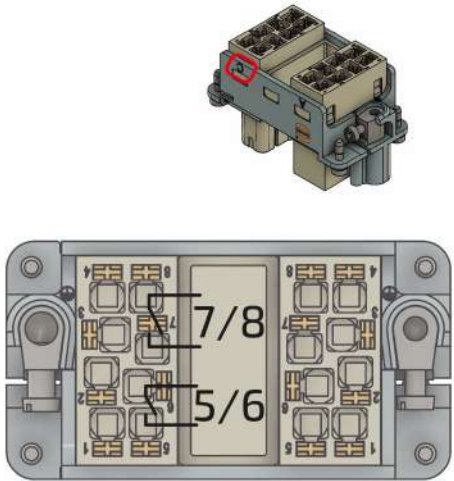
	<p>The pin assignment of the Harting plug (16-pin) is shown in detail below.</p>
---	--

Item	Description
1	RS485 connection — Inverter
2	RS485 connection — External devices
3	Analog output (0 to 10 V)
4	12 V DC (12 V; GND)
5	3 x digital inputs
6	Digital input for § 14a
7	Relay 5 (24 V; 1 A)
8	Relay 6 (24 V; 1 A)
9	PE connection

Table 42. Connector — Pin assignment: Control connector

11.1. Connection of a heat pump via "SG-Ready"

The integration of an "SG-Ready" (Smart Grid-ready) heat pump is an advanced form of sector coupling of electricity and heat - often also referred to as a "power-to-heat" application. The control system ensures that the heat pump slightly overheats the thermal energy storage system at times when cheap (solar) electricity is available in order to save electrical energy at times when there is no cheap surplus electricity.

	<ol style="list-style-type: none"> 1. The internal relay contacts 5 and 6 can be connected via pins 5/6 and 7/8 on the Harting plug (16-pin — C). 2. For detailed information on connecting the heat pump, please refer to the manufacturer's installation instructions.
--	--



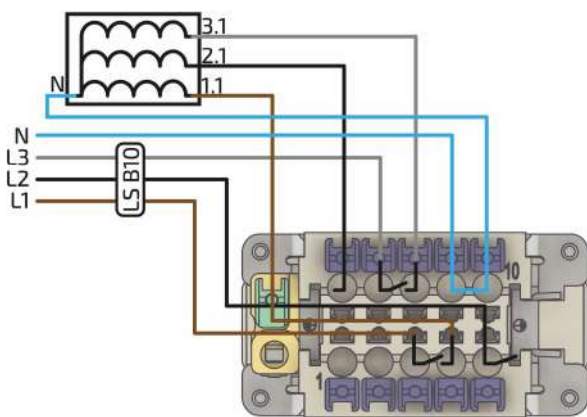
After installing the components, the app still needs to be installed. To do this, proceed as described in the section [Activation of the app in the FEMS App Center](#).

11.2. Connection of a heating element with a maximum of 6 kW

11.2. Connection of a heating element with a maximum of 6 kW

The integration of an electric heating element is the simplest and cheapest form of sector coupling of electricity and heat — often also called a "power-to-heat" application.

If the capacity of the electrical energy storage system is exhausted, self-generated energy must be fed into the public grid with low remuneration. In these cases, it often makes sense to use the surplus current for water heating (e. g. for hot water buffer tanks, pool heating, etc.). This way, other energy sources (e. g. wood or oil) can be saved.



1. So that each phase of the heating element can be controlled separately, each phase must be connected individually to a relay.
2. To do this, connect phase 1 (brown) to pin 3 on the Harting plug (10-pin). Continue from pin 4 to the heating element. Use pins 5/6 and 7/8 for phase 2 (black) and phase 3 (gray).
3. Loop through the neutral conductor N via pin 9/10.
4. A cable (5G1.5) from the sub-distribution board to the Harting plug and a cable (5G1.5) from the Harting plug to the heating element are recommended.
5. For detailed information on connecting the heating element, please refer to the manufacturer's installation instructions.



Ensure that three different phases are used. If only one phase is used, damage may occur.



After installing the components, the app still needs to be installed. To do this, proceed as described in the section [Activation of the app in the FEMS App Center](#).



Manual mode is only suitable for temporary operation. For permanent operation, the external relay control must be used.

11.3. Control of a heating element greater than 6 kW
(control via external relay)



The externally installed relays must be laid out according to the power of the installed heating element.

	<ol style="list-style-type: none"> 1. So that each phase of the heating element can be controlled separately, each phase must be connected individually to the internal relay via an additional external relay. 2. Connect L1 to pin 3 via a MCB B6 fused. Route phase L1 from pin 4 to the external relay and connect to A1. A2 must be connected to neutral. 3. Proceed in the same way as step 2 with the other two phases. Connect K2 and K3 via pins 5/6 and 7/8.
	<ol style="list-style-type: none"> 4. As an alternative to L2/L3, L1 can of course also be looped through, or: 5. Alternatively, control the contactors/relays with 24 V. If another voltage source is used, do not connect A2 to N.
	<ol style="list-style-type: none"> 6. The power supply of the heating element must then be connected to the switching contacts of the relays. 7. For detailed information on connecting the heating element, please refer to the manufacturer's installation instructions.



After installing the components, the app still needs to be installed. To do this, proceed as described in the section [Activation of the app in the FEMS App Center](#).

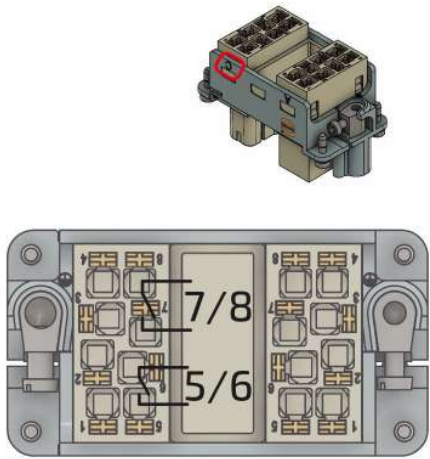
11.4. Controlling a CHP unit

11.4. Controlling a CHP unit

The integration of a combined heat and power plant (CHP) into electrical energy management is an advanced form of sector coupling of electricity and heat.

This allows using the CHP as an electrical generator that is independent of the time of day and weather conditions. When the state of charge of the electrical energy storage system is low, the CHP is given a switch-on signal to produce electricity. This is useful, for example, if the battery capacity is not sufficient to cover electricity consumption at night. This avoids the need to purchase expensive current from the grid.

When the battery is charging, this signal is stopped again to prevent the CHP's current from being fed into the grid unnecessarily.

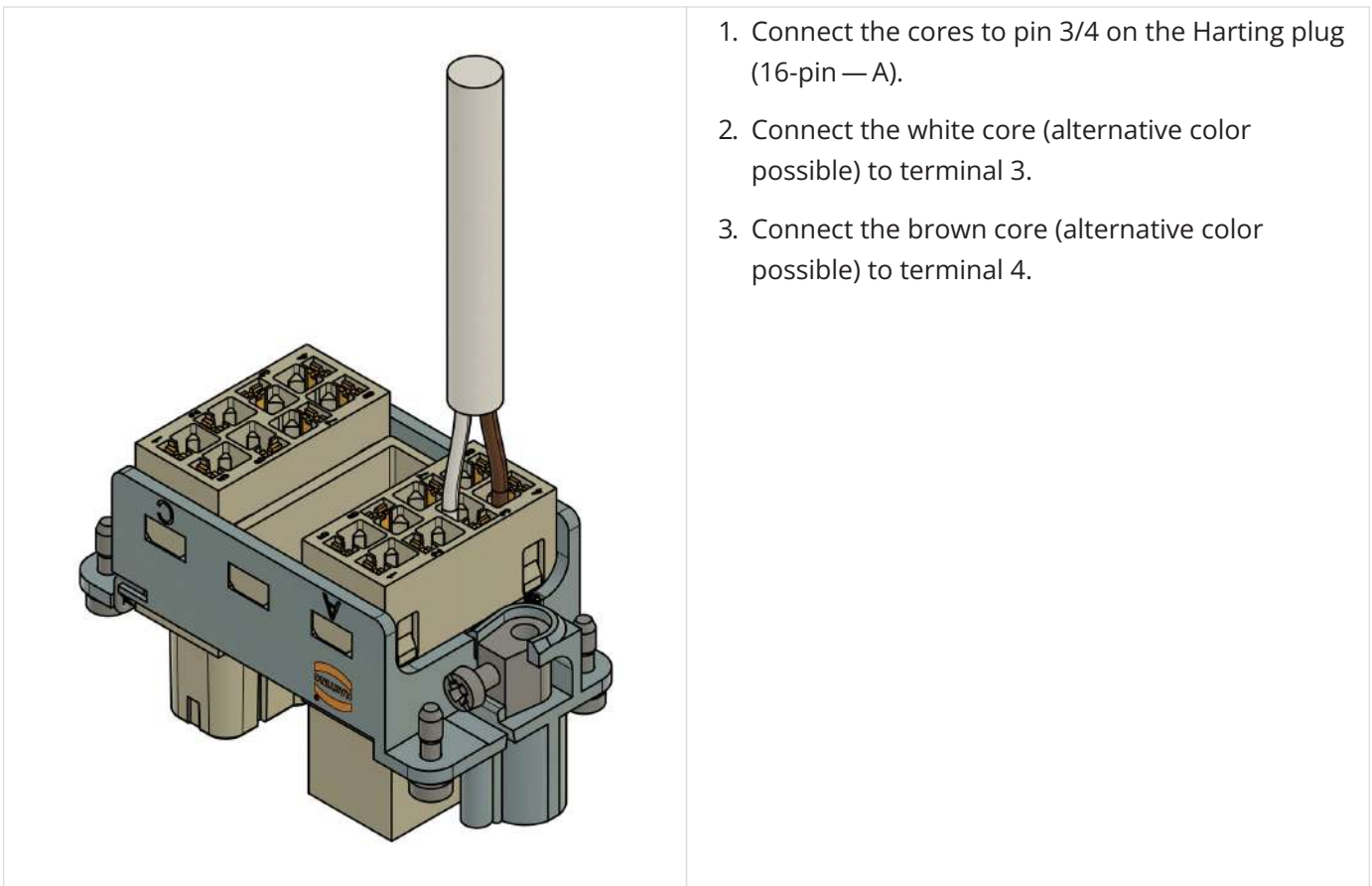
	<ol style="list-style-type: none"> 1. The enable signal for starting the CHP can be connected to pins 5/6 via the Harting plug (16-pin — C). 2. For detailed information on connecting the CHP, please refer to the manufacturer's installation instructions.
--	---



After installing the components, the app still needs to be installed. To do this, proceed as described in the section [Activation of the app in the FEMS App Center](#).

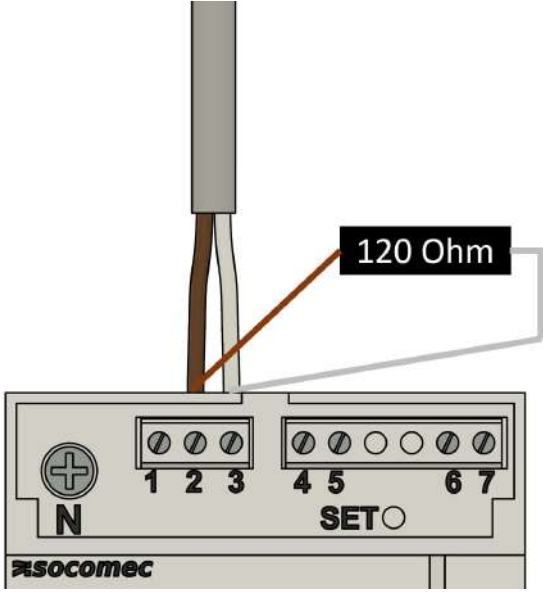
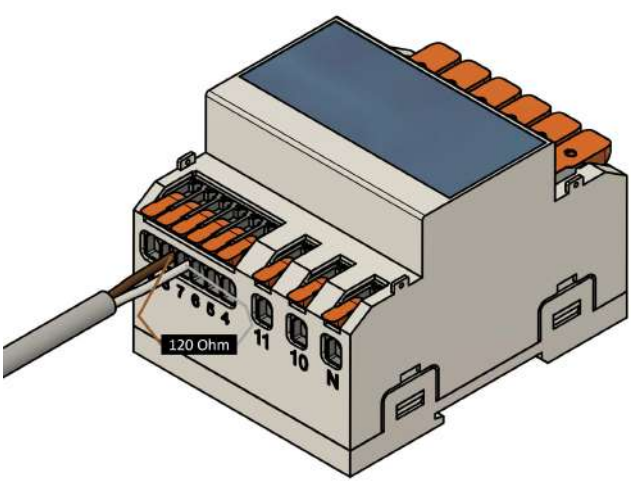
11.5. Additional AC meter

- If additional meters have been installed for monitoring other consumer loads or generators, these must be integrated into the circuit in accordance with the manufacturer's instructions.
- The communicative integration is shown below using a 3-phase sensor without a current transformer as an example.
- Only meters approved by FENECON can be integrated.
- The first production meter is always integrated with Modbus ID 6. All others in ascending order. The baud rate is 9600.



1. Connect the cores to pin 3/4 on the Harting plug (16-pin — A).
2. Connect the white core (alternative color possible) to terminal 3.
3. Connect the brown core (alternative color possible) to terminal 4.

11.5. Additional AC meter

	<p>For example SOCOMEC E24</p> <ol style="list-style-type: none"> The brown wire (alternative color possible) is connected to the meter at connection point 2 and the white core (alternative color possible) is then connected to 3. A terminal resistor with 120 Ω must be installed between (+) and (-) (A/B) on the last bus device.
	<p>For example KDK 4PU</p> <ol style="list-style-type: none"> The brown wire (alternative color possible) is connected to the meter at connection point 8 and the white core (alternative color possible) is then connected to 7. A terminal resistor with 120 Ω must be installed between (+) and (-) (A/B) on the last bus device.



If several meters are to be installed, they can be connected in series for communication purposes. For this purpose, the first meter can be bridged to the second, etc. The Modbus address must be set in ascending order.

[Link to the overview page of the installation and configuration instructions for energy meters](#)




Once the components have been installed, the app still needs to be installed.

- To do this, proceed as described in the section [Activation of the app in the FEMS App Center](#).

11.6. Activation of the app in the FEMS App Center

After installing the hardware FEMS App extension, it still needs to be activated in the App Center. To do this, proceed as follows:

	<ol style="list-style-type: none"> 1. https://portal.fenecon.de
	<ol style="list-style-type: none"> 2. Log in with your installer account.



First check whether updates are available for the FEMS.

12. Updating the FEMS

To be able to use all FEMS Apps extensively and in the latest version, carry out a system update to the latest version.

1. Open the ☰ burger menu at the top left of FENECON Online Monitoring.

12. Updating the FEMS

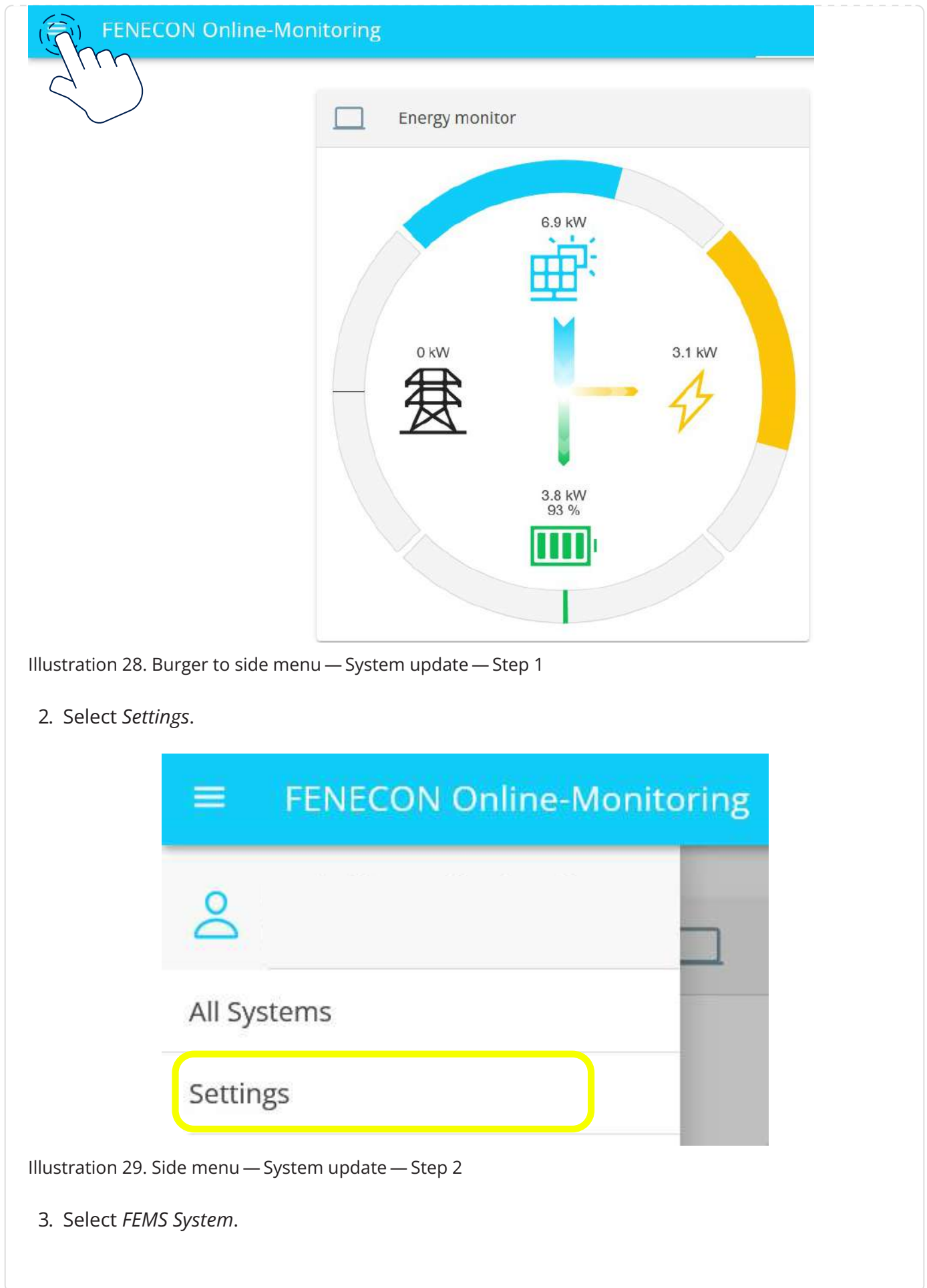


Illustration 28. Burger to side menu — System update — Step 1

2. Select *Settings*.

Illustration 29. Side menu — System update — Step 2

3. Select *FEMS System*.

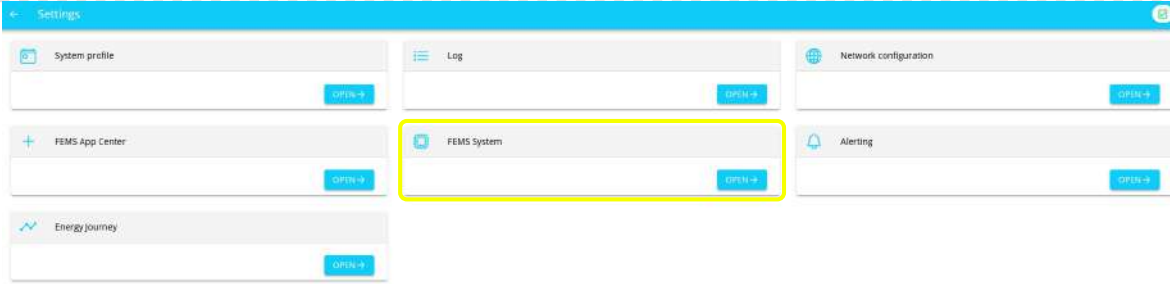


Illustration 30. App Center — System update — Step 3

4. Click on *INSTALL LATEST VERSION* to update the system. If the latest version is already installed, you do not need to do anything else.



Illustration 31. App Center — System update — Step 4



To return to the settings menu after the FEMS system update:
 Click on the arrow ← at the top left. This applies to all submenus in the **Settings** area.



Illustration 32. Back to the Settings menu

13. Starting point: FEMS App Center

1. After you have performed a system update, open the *FEMS App Center*.
 - a. Alternatively, go to the *FEMS App Center* via the ☰ top left burger menu in the FENECON Monitoring.

13.1. Installation of further FEMS Apps

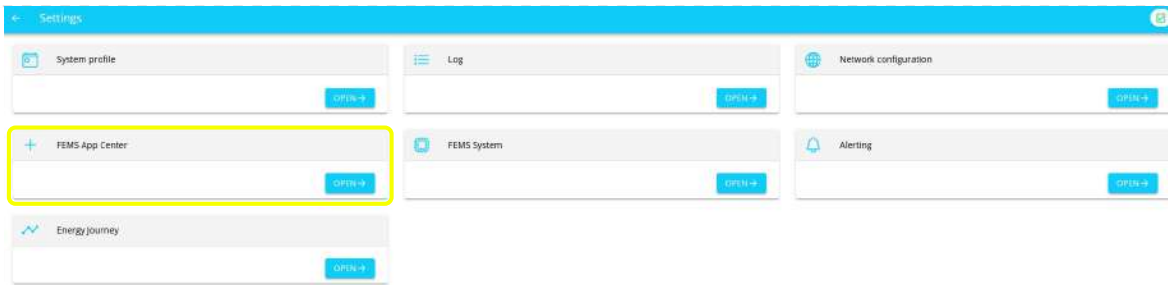


Illustration 33. App Center — Step 1

2. You are now in the App Center. From here you can redeem and register licence keys for apps, install new apps and edit or subsequently configure apps that are already installed.



Illustration 34. App Center — Step 2

13.1. Installation of further FEMS Apps

The following instructions show an example of how to install an FEMS App PV inverter.

There are two ways to install an FEMS App via the App Center.

13.1.1. Installation after redeeming a licence key

After a licence key has been redeemed, a selection of available apps that can be installed is displayed.

The App Center offers a search bar and a filter option to get to the desired app more quickly:

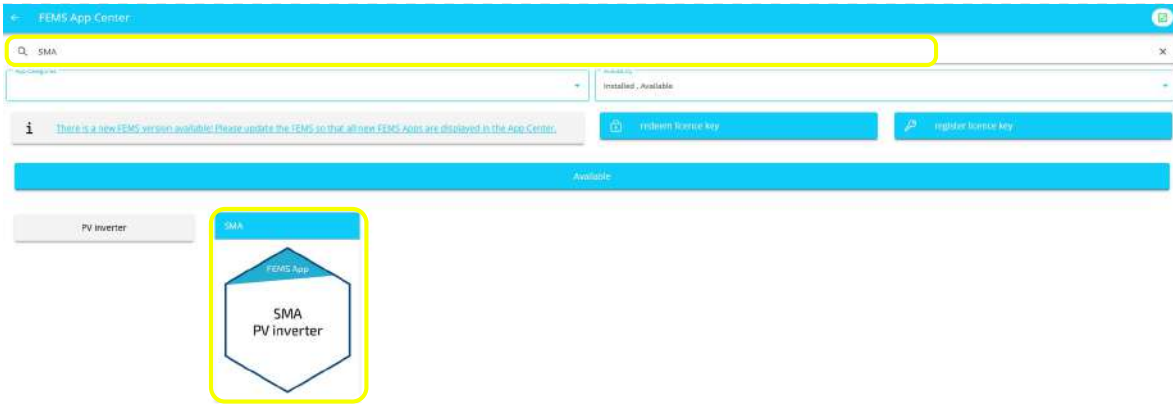


Illustration 35. Search for a specific app in the App Center

In the example, the **FEMS App SMA PV Inverter** was searched for. This app is selected by clicking or tapping on the tile.

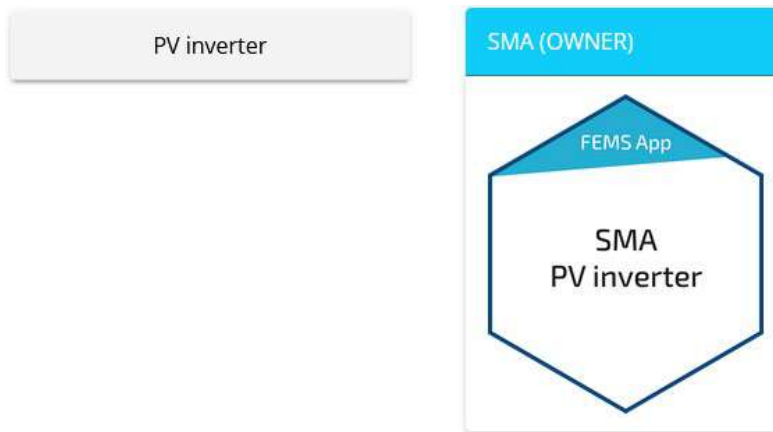


Illustration 36. App installation — Variant 1 — Step 1

You will then be taken to the app overview:

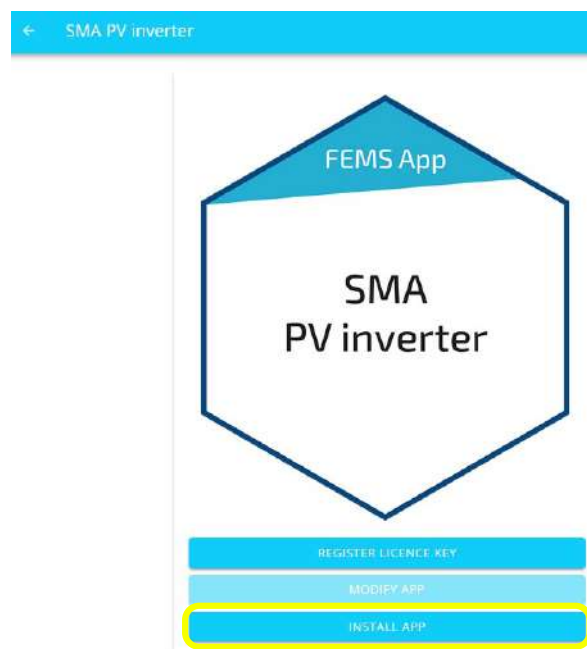


Illustration 37. App installation — Variant 1 — Step 2

13.1. Installation of further FEMS Apps

Select the *INSTALL APP* button.

You will then be taken to the installation wizard for the respective app:



Illustration 38. App installation — Variant 1 — Step 3

Some of the input fields are pre-filled. Nevertheless, enter your data if it differs from the default values (e. g. IP address). Otherwise, the default values can be retained (e. g. port, Modbus unit ID).



Mandatory fields are marked with (*)



Check your entries and make sure that they are correct. Otherwise the respective app will not work properly!

Select the *INSTALL APP* button again.

Once the installation process has been successfully completed, the new app will appear in the App Center overview in the **Installed** category.

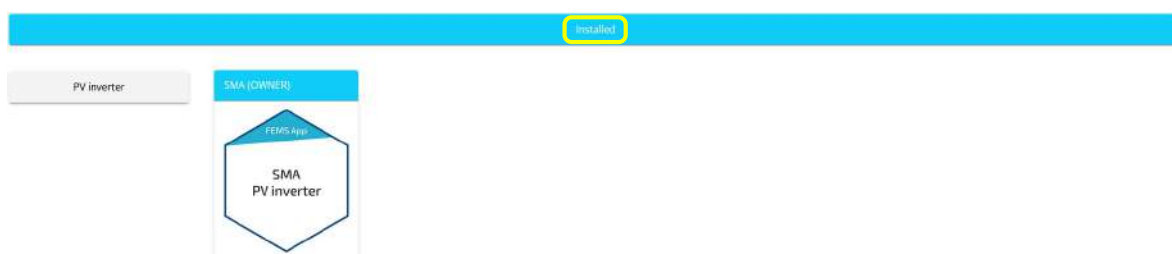


Illustration 39. App installation — Variant 1 — Step 4

13.1.2. Direct installation

You can also install an app directly. To do this, go to the App Center overview and search for the desired app.



Only apps from the "Available" category can be installed.

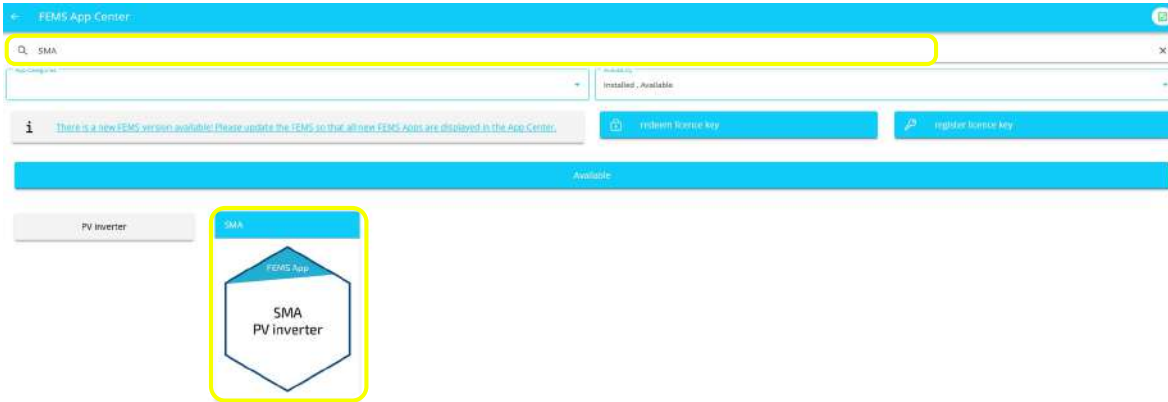


Illustration 40. Search for a specific app in the App Center

In the example, the **FEMS App SMA PV Inverter** was searched for. This app is selected by clicking or tapping on the tile.

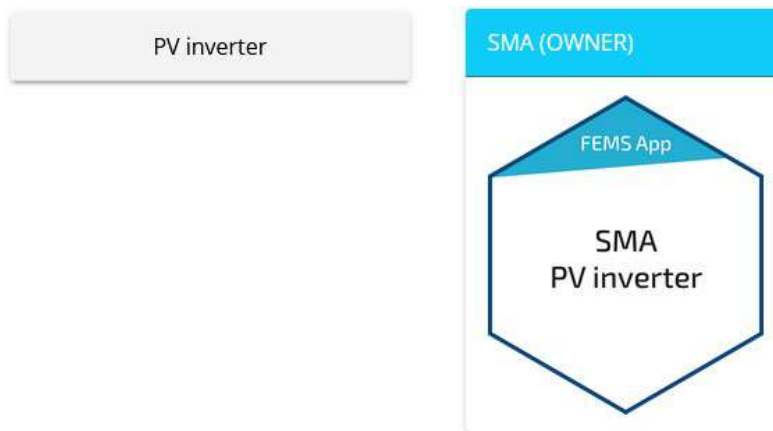


Illustration 41. App installation — Variant 2 — Step 1

You will then be taken to the individual view of the app:

13.1. Installation of further FEMS Apps

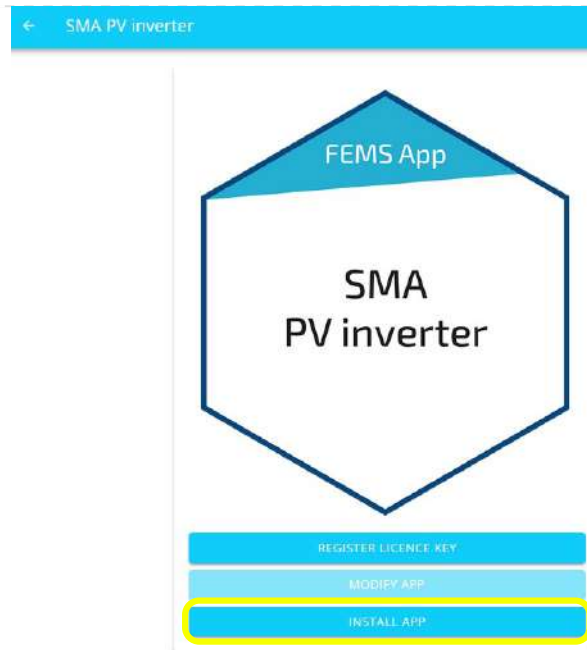


Illustration 42. App installation — Variant 2 — Step 2

Select the *INSTALL APP* button.

An input mask for redeeming a licence key appears:

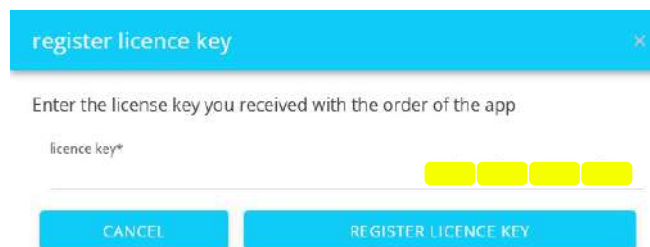


Illustration 43. App installation — Variant 2 — Step 3

You have two options here:

Redeem a new licence key directly

If you have not yet registered a licence key or wish to redeem a new licence key, enter the 16-digit key in the corresponding field and then click on *VALIDATE LICENCE KEY*.

The entered licence key is then checked for validity.

Illustration 44. Redeem new licence key directly

If the licence key is valid, it can be registered by clicking on the button of the same name.

REDEEM LICENCE KEY



If the licence key is invalid, please check your entry and try again.

Redeem an already registered licence key

In this case, the button in the App Center looks like this:



If you want to redeem an already registered licence key, check the corresponding box and select the appropriate, already registered licence key via ▼ drop-down menu.

Illustration 45. Redeem already registered licence key

Then click on the *REDEEM LICENCE KEY* button.

You will then be taken to the installation wizard for the respective app.

13.1. Installation of further FEMS Apps



Illustration 46. App installation — Variant 2 — Step 4

Some of the input fields are pre-filled. Nevertheless, enter your data if it differs from the default values (e. g. IP address). Otherwise, the default values can be retained (e. g. port, Modbus unit ID).



Mandatory fields are marked with (*)



Check your entries and make sure that they are correct. Otherwise the respective app will not work properly!

Select the *INSTALL APP* button again.

Once the installation process is complete, the new app will appear in the App Center overview in the **Installed** category.



Illustration 47. App installation — Variant 2 — Step 5

14. External control of the inverter

There are various ways to override the inverter from external devices.

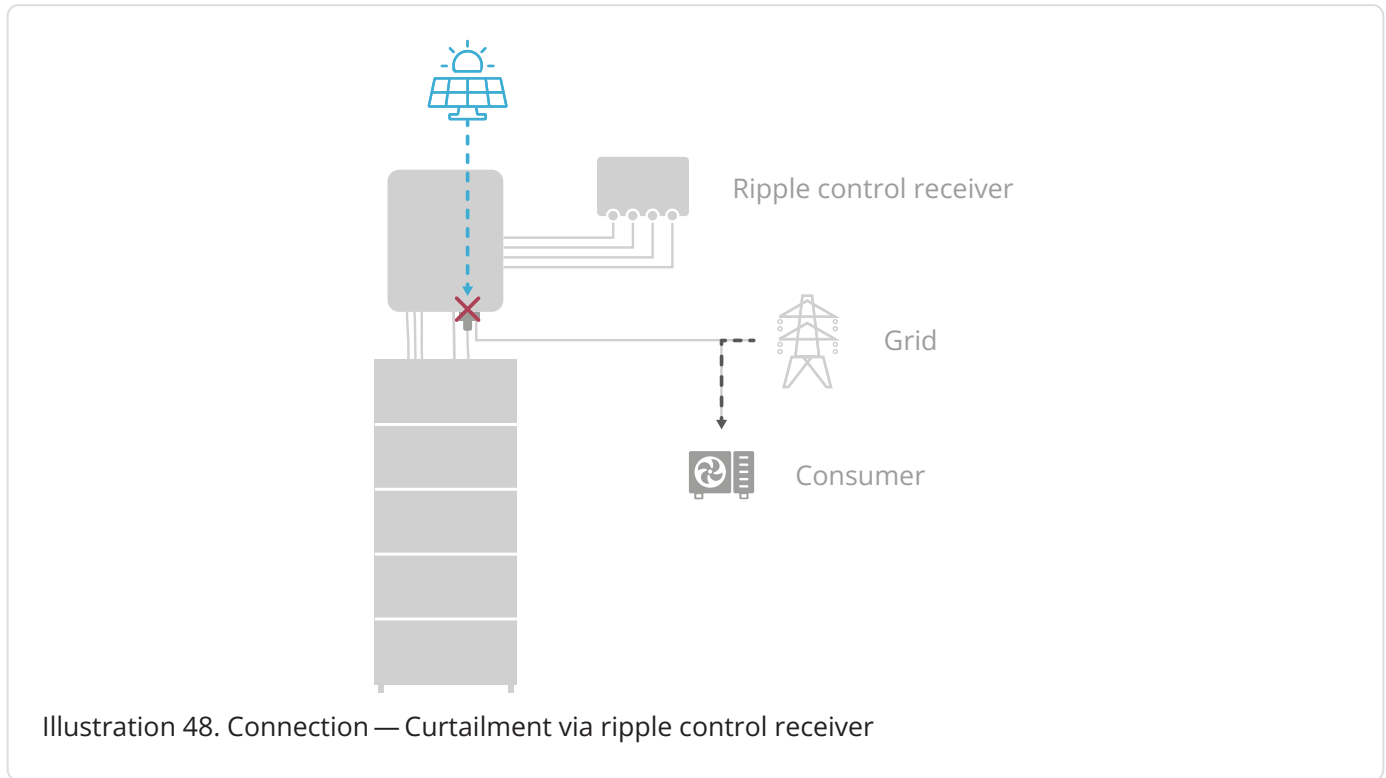


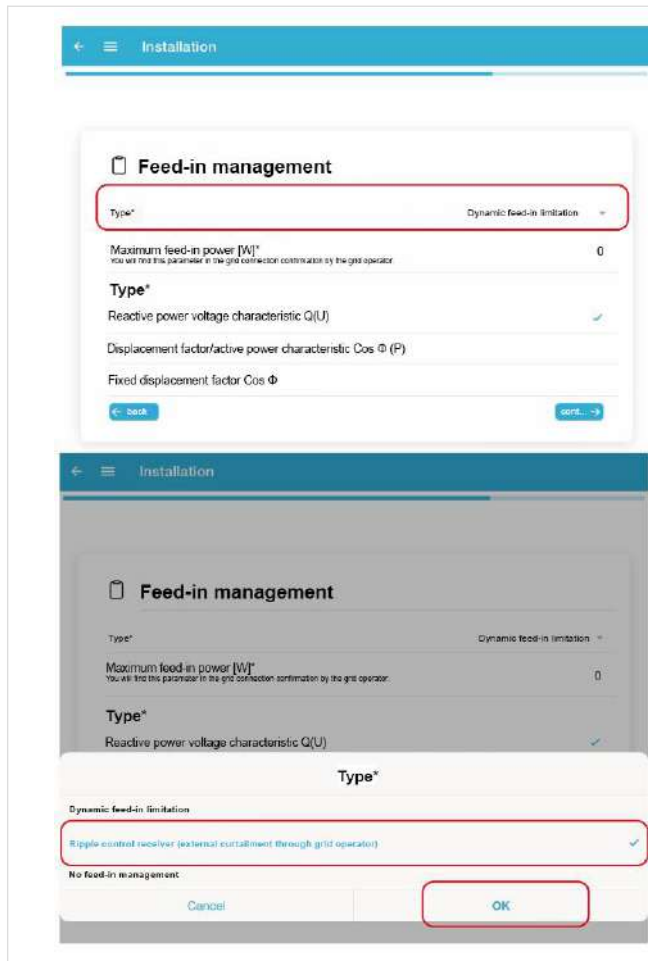
Illustration 48. Connection — Curtailment via ripple control receiver

14.1. Ripple control receiver at the AC output

The inverter can be controlled directly via a ripple control receiver. The following plugs supplied with the inverter are required for this.

	<ol style="list-style-type: none"> 1. The inverter's small parts box contains three plugs that can be plugged into the underside of the inverter.
	<ol style="list-style-type: none"> 2. The plugs are numbered consecutively.

14.1. Ripple control receiver at the AC output



3. In order for the functions to be activated, activate the ripple control receiver during commissioning.
4. Then confirm with *OK*.

The active power of the FENECON Home 20 & 30 inverter can be controlled directly by the energy supply company (grid operator) via a ripple control receiver (RCR).


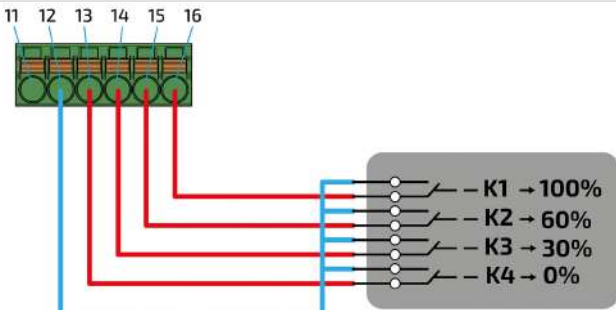
The behavior of the inverter in the various control stages can be described as follows.

- 100 % Standard signal, inverter works without restrictions (20/30 kW)
- 60 % Inverter output power is reduced to 60 %. (12/18 kW)
- 30 % Inverter output power is reduced to 30 %. (6/9 kW)
- 0 % Inverter output power is reduced to 0 %. (0/0 kW)

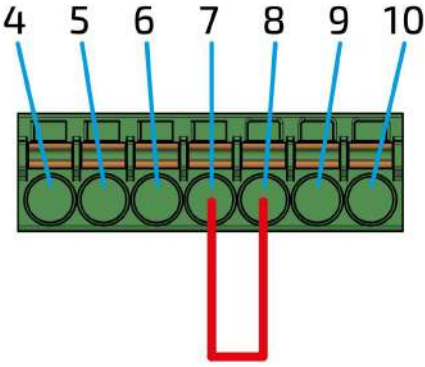
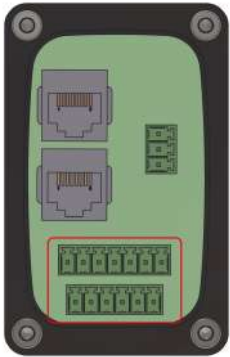

If other inverters are used, these must also be connected separately to the RCR; how exactly depends on the grid operator and the RCR used.



In the event of a curtailment to 0 %, the grid feed-in of the inverter is stopped completely, i.e. the consumer loads are supplied completely from the grid. Only the battery continues to be charged.

	<ol style="list-style-type: none"> 1. A cable with at least 5 cores with a cross-section of 0.34 mm² to 0.75 mm² is recommended. 2. Feed the cable through one of the holes of the multi-hole seal. 3. <i>Attention:</i> One feedthrough is already blocked by the communication cable between the inverter and EMS. 4. Leave the other openings of the multi-hole seal closed.
	<ol style="list-style-type: none"> 5. Connect the cores of the control cable as shown in the picture.

14.1. Ripple control receiver at the AC output

	<p>6. In order for the inverter to synchronize to the grid, a jumper must be connected between pin 7 and pin 8.</p> <p>7. A core with a cross-section of 0.34 mm² to 0.75 mm² is recommended.</p>
	<p>8. Plug in the two connectors on the underside of the inverter.</p>
	<p>9. Attach the cover to the inverter and tighten the bolt connection.</p>

14.2. Ripple control receiver on grid connection point

The system can be controlled directly via the ripple control receiver (RCR).



Observe the specifications of your grid operator when connecting the external radio ripple control receiver.

If other inverters are used, these must also be connected separately to the RCR; how exactly depends on the grid operator and the RCR used.

The behavior of the inverter in the various control stages can be described as follows:

- 100 % Standard signal, inverter works without restrictions (20/30 kW).
- 60 % Feed-in power at the grid connection point is reduced to 60 % (12/18 kW).
- 30 % Feed-in power at the grid connection point is reduced to 30 % (6/9 kW).
- 0 % Feed-in power at the grid connection point is reduced to 0 % (0/0 kW).

When connecting to the FEMS box, the following contacts must be connected in the Harting connector:

14.2. Ripple control receiver on grid connection point

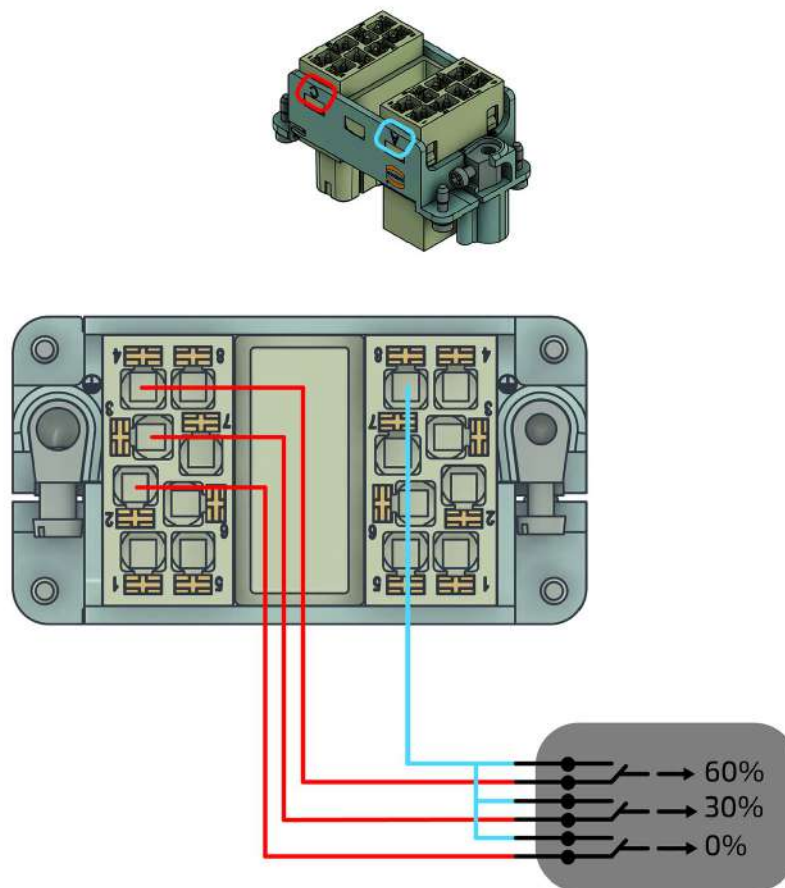
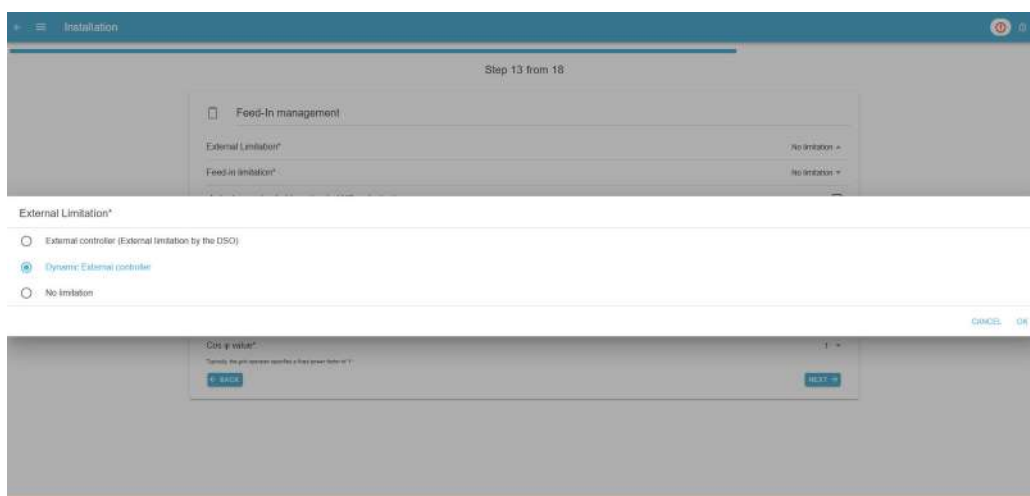


Illustration 49. Connection — Ripple control receiver on GCP — Home 20 & 30

During commissioning, the **dynamic ripple control receiver** must be selected under *External limitations*:



The ripple control receiver now regulates the grid limitation to the grid connection point and no longer to the AC output. This means that it is also possible to charge the battery and supply the consumer loads with PV production in the event of grid limitation.

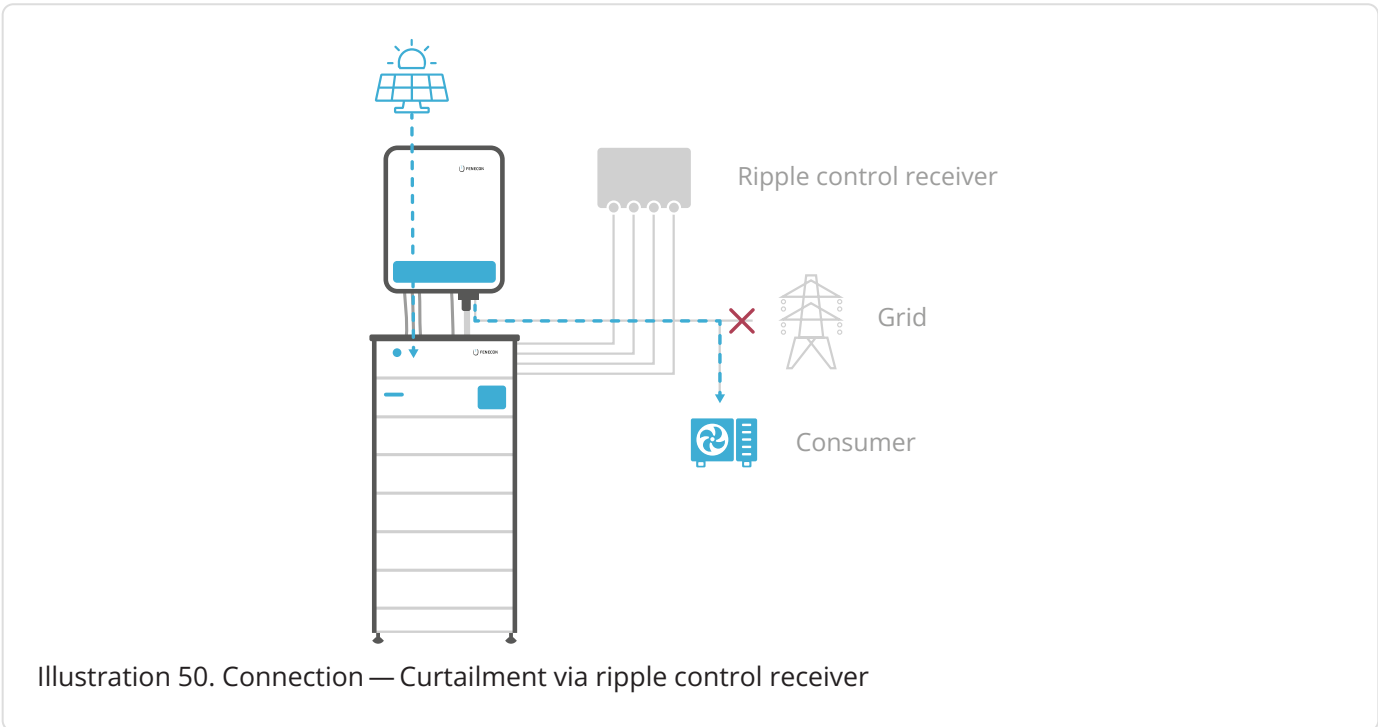

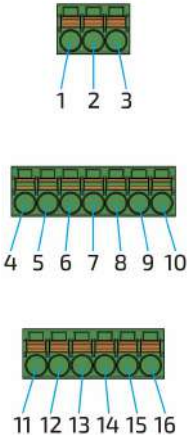
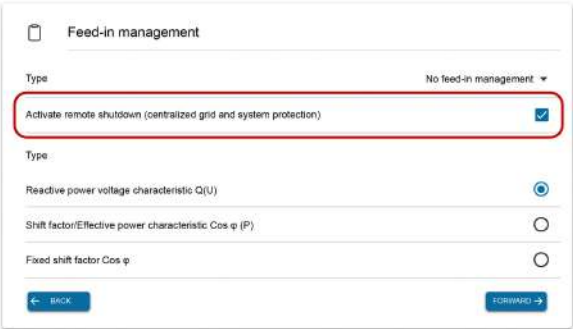


Illustration 50. Connection — Curtailment via ripple control receiver

14.3. Remote shutdown


14.3. Remote shutdown

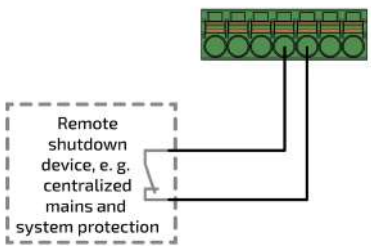
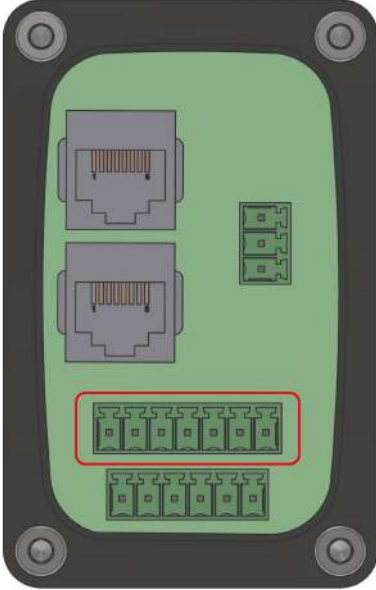

The inverter can be disconnected from the grid when remote disconnection is activated, e. g. via a central grid and plant protection. One of the following plugs supplied with the inverter is required for this.

	<ol style="list-style-type: none"> 1. The inverter's small parts box contains three plugs that can be plugged into the underside of the inverter.
	<ol style="list-style-type: none"> 2. The plugs are numbered consecutively
<p style="text-align: center;">Step 14 of 18</p> 	<ol style="list-style-type: none"> 3. To activate the functions, the remote switch-off must be activated during commissioning. 4. Then confirm with <i>OK</i>. 5. Continue to the next step with <i>Next</i>.



The emergency power output is still active (if activated) and supplies the emergency power to the consumer loads.

	<ol style="list-style-type: none"> 1. A cable with 2 cores and a cross-section of 0.34 mm² to 0.75 mm² is recommended. 2. Feed the cable through one of the holes in the multi-hole seal of the cover. 3. Attention: One feedthrough is already blocked by the communication cable between the inverter and EMS. 4. Leave the other openings of the multi-hole seal closed.
---	---

	<ol style="list-style-type: none"> The core of the disconnection device must be connected to pin 7 and pin 8 so that the inverter can be disconnected from the grid. The switch-off device must be equipped with a break contact In normal operation, pins 7 and 8 must be bridged via the switch-off device.
	<ol style="list-style-type: none"> Plugging in the 7-pin connector on the underside of the inverter.
	<ol style="list-style-type: none"> Attach the cover to the inverter and tighten the bolt connection.

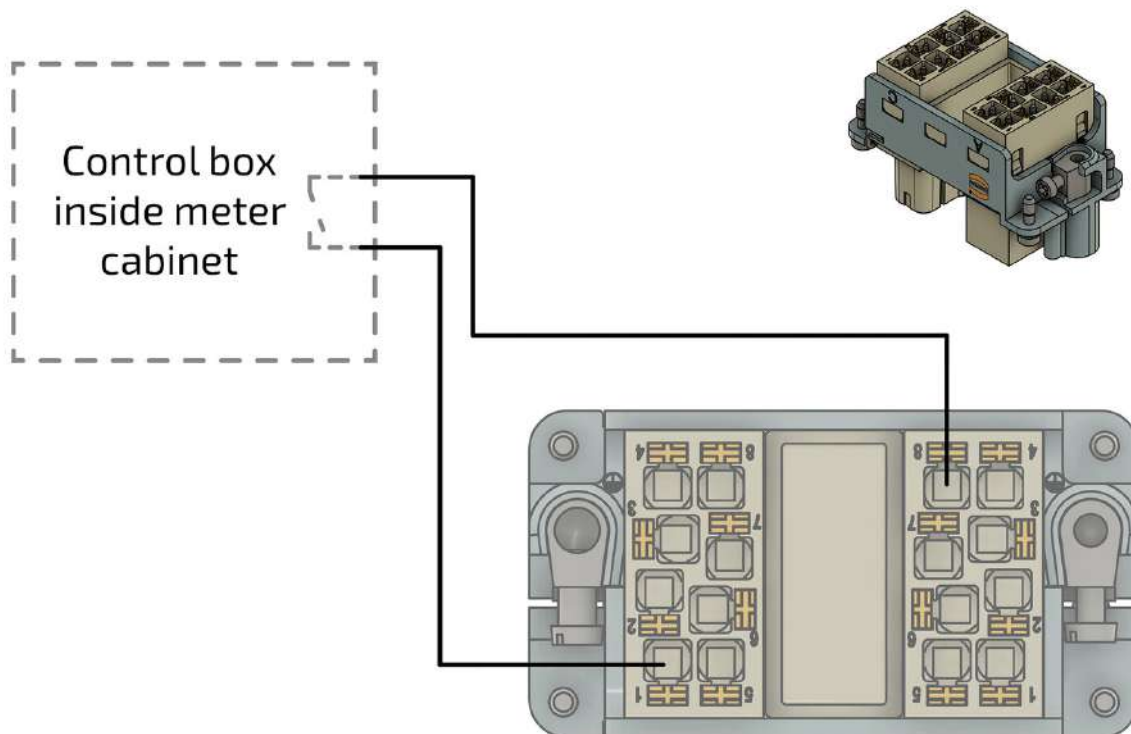


This method can also be used to connect *P_{ave} monitoring*.

14.4. Section 14a of the Energy Industry Act (EnWG)

14.4. Section 14a of the Energy Industry Act (EnWG)

The inverter can be limited to a maximum reference power of 4.2 kW. The digital input of the EMS must be assigned for this.






1. The signal can be connected to pins 1 (C) and 8 (A) via the Harting plug (16-pin — A & C).
2. For detailed information on connecting the FNN control box, please refer to the manufacturer's installation instructions.

15. Troubleshooting

15.1. Errors in Online Monitoring

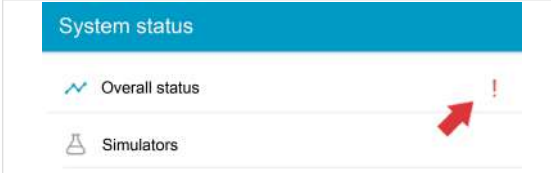
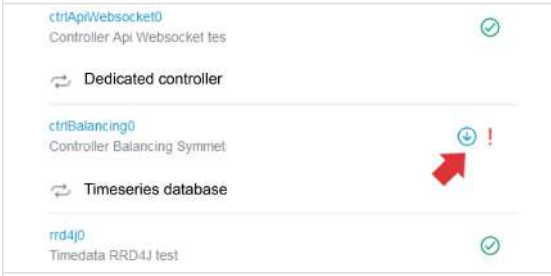

The system status can be checked after logging in at the top right using the color of the icon. A green tick indicates that everything is OK, an orange exclamation mark indicates a warning (*Warning*) and a red exclamation mark indicates an error (*Fault*).

15.1.1. Fault display


	<p>System status: Everything is OK</p>
	<p>System status: Warning</p>
	<p>System status: Error (Fault)</p>

15.1. Errors in Online Monitoring

15.1.2. Troubleshooting

	<p>You can get a detailed overview of an existing warning or error by clicking on the exclamation mark in the top right-hand corner.</p>
	<p>The scroll bar can be used to examine the origin of the warning or error in more detail. In this example, the error lies with the controller used.</p>
	<p>Clicking on the icon (down arrow) displays a more detailed error description depending on the error.</p>

In the example above, an incorrect reference for the grid meter was intentionally entered for test purposes, which is why the controller execution fails.

	<p>Under certain circumstances, it may happen that the FEMS is not accessible and the error message opposite appears.</p>
---	---

If the FEMS is offline, follow the steps displayed below the message.

15.2. FENECON Home 20 & 30 inverter

15.2.1. Fault display

Faults are indicated by a red LED next to "SYSTEM".

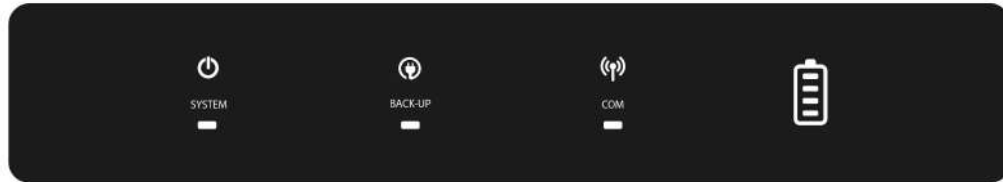


Illustration 51. Fault display on the FENECON Home 20 & 30 inverter

15.2. FENECON Home 20 & 30 inverter

15.2.2. Rotary field of the grid connection

- Check whether a clockwise rotating field is present at the grid connection.
- Otherwise, contact the FENECON Service. You can find the contact details in the [Service](#) section.

The LEDs display further information on the status of the inverter.














Display	Status	Description
		The inverter is switched on and in standby mode.
		The inverter is starting and is in self-test mode.
		The inverter is running normally in grid-parallel or stand-alone mode.
		Overloading of the RESERVE output.
		An error has occurred.
		The inverter is switched off.
		The grid is abnormal and the inverter is in stand-alone mode.
		The grid is normal and the inverter is in parallel mains operation.
		RESERVE is switched off.
		The inverter is not connected to the internet. Communication takes place via the EMS box. Therefore, there is no LED indication here.

Table 43. LED status displays — Inverter

15.3. Battery tower

15.3.1. Fault display

Faults are displayed on the BMS box via a red LED.

The various errors are indicated by LED codes.

15.3. Battery tower

System status	System information	LEDs				
		blue/red	1	2	3	4
Bootloader		★	★	★	★	★
Start	Master/Slave	●	★	★	★	★
	Parallel Box	●				★
	Extension Box	●			★	
Check mode	Individual or parallel connection	★				
			SoC display			
Charging	0 % to 25.0 % SoC	●	■			
	25.1 % to 50.0 % SoC	●	■	■		
	50.1 % to 75.0 % SoC	●	■	■	■	
	75.1 % to 99.9 % SoC	●	■	■	■	■
	100 % SoC	●	●	●	●	●
Discharging and standby	100 % to 75.1 %	●	●	●	●	●
	75.0 % to 50.1 %	●	●	●		
	50.0 % to 25.1 %	●	●			
	25.0 % to 0 %	●	●			
Error	Overvoltage	●				●
	Undervoltage	●			●	
	Overtemperature	●			●	●
	Undertemperature	●		●		
	Overcurrent	●		●		
	SoH too low	●		●	●	
	Int. communication	●		●	●	●
	Ext. communication	●	●			
	Parallel address error	●	●			●
	Module address error	●	●		●	
	BMS box fuse	●	●		●	●
	Module fuse	●	●	●		
	Contact error	●	●	●		●
	Insulation error	●	●	●	●	
BMS error	●	●	●	●	●	

●	Blue permanently on
■	Blinking blue
★	Blue flashing quickly
●	Red permanently on

15.3.2. Troubleshooting

If faults cannot be rectified or in the event of faults that are not included in the fault list, contact FENECON Service. Cf. [Service](#).

15.4. Fault list

Component	Error/fault	Measure
Battery module	The battery module has become wet	Do not touch Contact FENECON Service immediately for technical support
Battery module	The battery module is damaged	A damaged battery module is dangerous and must be handled with the utmost care. Damaged battery modules must no longer be used. If you suspect that the battery module is damaged, stop operation and contact FENECON Service

Table 44. Troubleshooting

15.5. Service

If the system malfunctions, contact the FENECON Service:

Phone: +49 (0) 9903 6280-0

E-mail: service@fenecon.de

Our service hours:

Mon.-Thurs. 08:00 to 12:00 | 13:00 to 17:00

Fri. 08:00 to 12:00 | 13:00 to 15:00

16. Technical maintenance

16. Technical maintenance

16.1. Tests and inspections



When carrying out inspection work, ensure that the product is in a safe condition. Improperly performed inspections can have serious consequences for people, the environment and the product itself.



Inspection work must only be carried out by trained and qualified specialists.



The maintenance instructions of the component manufacturer must be observed for all individual components.

Check the product and the cables regularly for visible external damage. In the event of defective components, contact [FENECON Service](#). Repairs must only be carried out by a qualified electrician.

16.2. Cleaning

Cleaning agents: The use of cleaning agents can damage the electrical energy storage unit and its parts.

It is recommended that the electrical energy storage unit and all its parts are only cleaned with a cloth moistened with clean water.



The entire product must be cleaned regularly. Only appropriate cleaning agents must be used for this purpose.

The cleaning agents must be free of chlorine, bromine, iodine or their salts. Steel wool, spatulas and the like must not be used for cleaning under any circumstances. The use of unsuitable cleaning agents can lead to external corrosion.

16.3. Maintenance work

No regular maintenance work needs to be carried out on the system. Nevertheless, check the status of your electrical energy storage system regularly.



Regular re-referencing of the electrical energy storage system is recommended, i.e. it must be completely discharged (SoC = 0 %) and then fully charged again (SoC = 100 %), as otherwise capacity may be lost.

16.4. Repairs

In the event of defective components, contact [FENECON Service](#).

16.5. Warranty cases

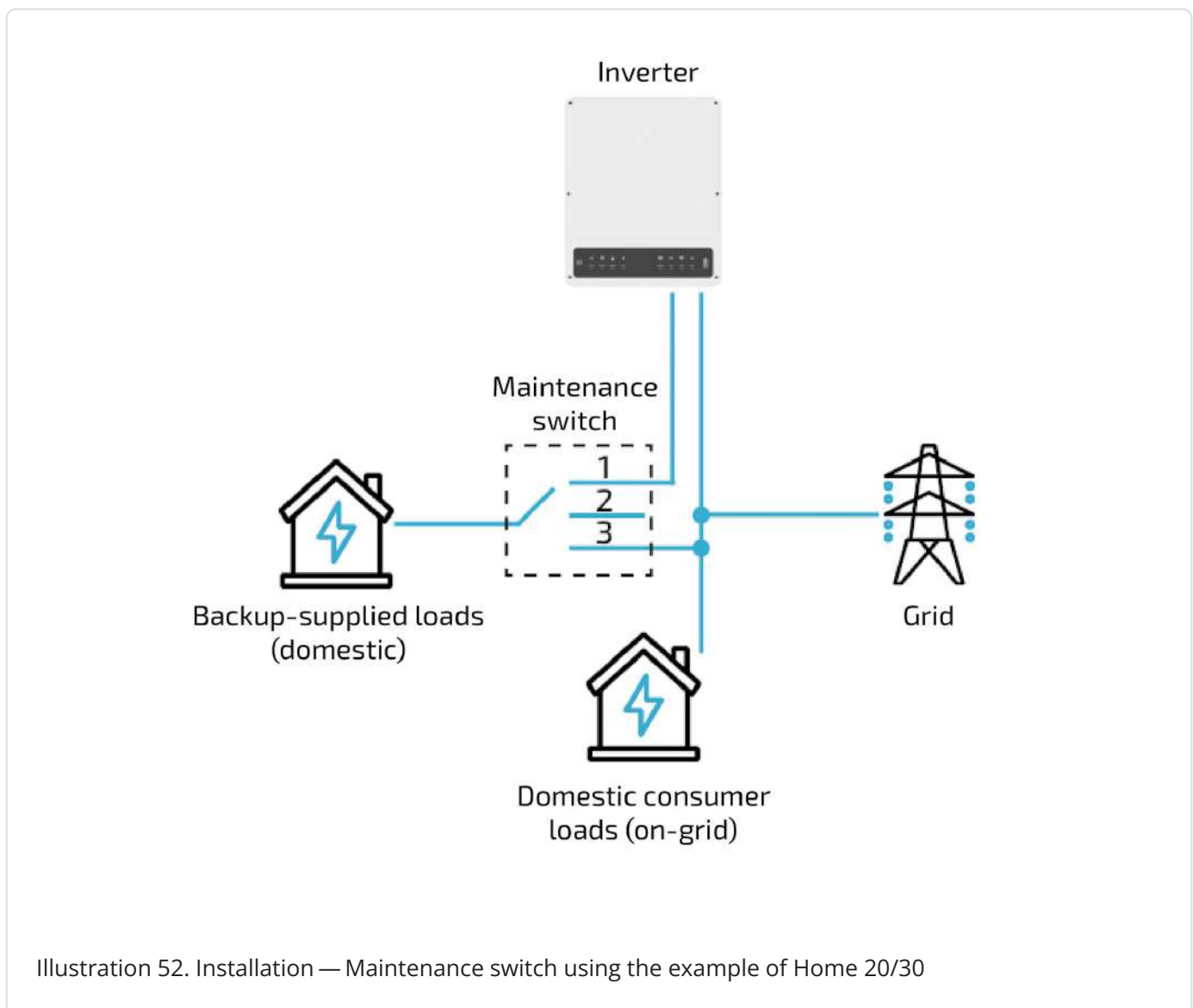
Warranty claims must be reported to FENECON in text form (e. g. [by e-mail](#)) within the warranty period. The notification must be made within a cut-off period of 8 weeks after the end customer has become aware of the warranty claim or could have become aware of it without gross negligence.

17. Advice for fire departments when dealing with FENECON Home & Commercial systems

17. Advice for fire departments when dealing with FENECON Home & Commercial systems

The FENECON Home and Commercial systems operate in the low-voltage range, which means that they are operated with voltages of less than 1,500 volts direct current (DC) and less than 1,000 volts alternating current (AC).

It may be useful to install an additional switch that disconnects the building from the emergency power supply. This makes it easier for the fire department to act safely and quickly in an emergency.



For a precise procedure for emergency services, it is recommended to ask the relevant fire academies and request the corresponding information sheets and pocket cards for battery energy storage systems.

18. Flood safety measures FENECON Home & Commercial

First steps after the water has receded

Even if your battery energy storage system looks undamaged on the outside:

- Do not put the system back into operation yourself.
- Ventilate the room well before entering (open windows from the outside if possible).
- Avoid sparks (no smoking, no lighters).

Why a review is important:

Even though LFP batteries are very safe, water or moisture can:

- Cause short circuits in the electronics.
- Trigger corrosion of electrical connections.
- Create isolation problems that only become apparent later.

These problems do not have to occur immediately, but can develop over weeks.

Commission a professional inspection

Please contact:

- Your installer or a qualified electrician with experience in battery energy storage systems.
- FENECON, the manufacturer of your system.
- Your insurance company — document the damage with photos.

The qualified specialist will check:

- Whether water has entered the system.
- Whether electronic components have been damaged.
- Whether a recommissioning is safely possible or a replacement is necessary.

No recommissioning without approval

Battery energy storage systems that have come into contact with water must only be put back into operation after a professional inspection and express approval by a qualified specialist. This is for your safety and is often also a prerequisite for your insurance cover.

When replacement is necessary

If your electrical energy storage system needs to be replaced:

18. Flood safety measures FENECON Home & Commercial

- The disposal of the defective system must be carried out professionally by specialized companies.
- Your installer will usually organize the removal and disposal.
- Do not attempt to transport damaged batteries yourself

Storage disposal until collection

If damaged battery modules cannot be collected immediately:

- Store them well ventilated outdoors with sufficient clearance from flammable materials.
Storage in a
 - Sand bed.
 - Fireproof container, not gas-tight, ventilated.
 - Water bath, e. g. metal tub, completely covered with water.
- Keep children and pets away.

Status: October 2025

Source: According to [Specifications of the German Energy Storage Systems Association \(BVES\) e.V.](#)

19. Handover to the operator

19.1. Information for the operator

The following information must be provided to the operator:

Component	Information/Document	Comment
System	FEMS number	
System	Login data for Online Monitoring	
System	Operating instructions	

Table 45. Information for the operator

20. Transport

20. Transport

This section contains information on external and internal transportation of the product.

Transportation is the movement of the product by manual or technical means.

- Only use suitable and tested lifting gear and hoists for transportation!



Risk due to lifted loads!
Standing under suspended loads is prohibited!



Check that the parts and outer packaging are in perfect condition.



Check that

- all screw and bolt connections are tightened firmly,
- the transport rail has been properly attached,
- you wear personal protective equipment (PPE).

- Ensure that nobody is on or near the product during transportation. Do not use people as counterweights.
- Ensure that nobody is below suspended loads.



Notes:

- The batteries are removed or replaced by specialist personnel and transported by a hazardous goods carrier.
- When transporting the batteries, observe the current laws, regulations and standards, e. g. the Hazardous Goods Transportation Act (GGBefG).



Legal regulations

The product is transported in accordance with the legal regulations of the country in which the product is transported off-site.

21. Dismantling and disposal

21.1. Prerequisites

- The power supply to the electrical energy storage unit is interrupted and secured against being switched on again.



Sharp and pointed edges

Injuries to the body or limbs caused by sharp and pointed edges.

- Always wear suitable protective equipment (cut-resistant protective gloves, protective footwear, protective eyewear) when working on the product!

21.2. Dismantling

- The electrical energy storage system may only be dismantled by authorized qualified electricians.
- Dismantling work must only be carried out when the system has been taken out of operation.
- Before starting disassembly, secure all components to be removed against falling, tipping over or moving.
- Dismantling work must only be carried out when the system is shut down and only by service personnel.
- The dismantling instructions of the component manufacturer (Appendix, Applicable documents) must be observed.
- When transporting the battery modules, the current laws, regulations and standards must be observed (e. g. Dangerous Goods Transportation Act — GGBefG).

21.3. Disposal

21.3. Disposal

- The FENECON electrical energy storage system must not be disposed of with normal household waste.
- The FENECON electrical energy storage system is RoHS and REACH compliant.
- Disposal of the product must comply with local regulations for disposal.
- Avoid exposing the battery modules to high temperatures or direct sunlight.
- Avoid exposing the battery modules to high humidity or corrosive atmospheres.
- Dispose of the electrical energy storage system and the batteries it contains in an environmentally friendly manner.
- Contact FENECON GmbH to dispose of the used batteries.



- For the disposal of all components, the usual procedures at the site and the applicable environmental protection regulations must be applied!
- For the disposal of auxiliary and operating materials, observe the local regulations and information from the safety data sheets.
- For disposal, please also observe the information in the individual operating instructions for the respective components.
- If in doubt about the disposal method, contact the manufacturer or the local waste disposal company.

22. Index

22.1. List of images

Illustration 1. Inverter — Dimensions

Illustration 2. Dimensions — EMS box

Illustration 3. Terminal assignment — EMS box

Illustration 4. Dimensions — Parallel box

Illustration 5. Terminal assignment — Parallel box

Illustration 6. Dimensions — Extension box

Illustration 7. Terminal assignment — Extension box

Illustration 8. Dimensions — BMS box

Illustration 9. Dimensions — Base

Illustration 10. Dimensions — Split base

Illustration 11. Dimensions — Top box

Illustration 12. System — schematic diagram with optional components (shown without protective device)

Illustration 13. Standard setup with emergency power (shown without protective device)

Illustration 14. System structure with additional PV producer (shown without protective device)

Illustration 15. AC system diagram (shown without protective device)

Illustration 16. System with manual emergency power switchover (shown without protective device)

Illustration 17. Structure FENECON Home 20 & 30 storage system with four battery towers

Illustration 18. Installation conditions

Illustration 19. Recommended distances at the installation site

Illustration 20. Installation conditions.

Illustration 21. Clearances at the installation site

Illustration 22. Arrangement of the module fastening

Illustration 23. Module mounting arrangement — Split base

Illustration 24. Approved network configurations for connecting the FENECON Home 20 & 30

Illustration 25. General information AC connection

Illustration 26. Recommended maintenance switch for emergency power outlet

Illustration 27. AC connection Energy meter

Illustration 28. Burger to side menu — System update — Step 1

Illustration 29. Side menu — System update — Step 2

Illustration 30. App Center — System update — Step 3

Illustration 31. App Center — System update — Step 4

Illustration 32. Back to the Settings menu

Illustration 33. App Center — Step 1

Illustration 34. App Center — Step 2

Illustration 35. Search for a specific app in the App Center

Illustration 36. App installation — Variant 1 — Step 1

Illustration 37. App installation — Variant 1 — Step 2

22.1. List of images

- Illustration 38. App installation — Variant 1 — Step 3
- Illustration 39. App installation — Variant 1 — Step 4
- Illustration 40. Search for a specific app in the App Center
- Illustration 41. App installation — Variant 2 — Step 1
- Illustration 42. App installation — Variant 2 — Step 2
- Illustration 43. App installation — Variant 2 — Step 3
- Illustration 44. Redeem new licence key directly
- Illustration 45. Redeem already registered licence key
- Illustration 46. App installation — Variant 2 — Step 4
- Illustration 47. App installation — Variant 2 — Step 5
- Illustration 48. Connection — Curtailment via ripple control receiver
- Illustration 49. Connection — Ripple control receiver on GCP — Home 20 & 30
- Illustration 50. Connection — Curtailment via ripple control receiver
- Illustration 51. Fault display on the FENECON Home 20 & 30 inverter
- Illustration 52. Installation — Maintenance switch using the example of Home 20/30

22.2. List of tables

Table 1. Version/revision

Table 2. Symbol conventions

Table 3. Terms and abbreviations

Table 4. Scope of delivery

Table 5. Documents

Table 6. Pictograms

Table 7. Technical data — General

Table 8. Technical data — Inverter

Table 9. Technical data — FENECON Home 20 & 30-EMS-Box

Table 10. Terminal assignment — EMS box

Table 11. Technical data — Parallel box

Table 12. Terminal assignment — Parallel box

Table 13. Extension box (optional) — Technical data

Table 14. Terminal assignment — Extension box

Table 15. Technical data — BMS box

Table 16. Technical data — Battery module

Table 17. Electrical parameters — Number of battery modules 4S to 6S (5 to 7 modules in series)

Table 18. Electrical parameters — Number of battery modules 7S to 10S (8 to 11 modules in series)

Table 19. Electrical parameters — Amount of battery modules 7S to 10S (12 to 15 modules in series)

Table 20. Technical data — Base

Table 21. Technical data — Split base

Table 22. Technical data — Top box

Table 23. Standard setup with back-up power

Table 24. System structure with additional PV producer

Table 25. AC system diagram

Table 26. System with manual emergency power changeover

Table 27. System configuration — Required components

Table 28. Scope of delivery — FENECON Home 20 & 30-Inverter

Table 29. Scope of delivery — FENECON Home 20 & 30-EMS-Box

Table 30. Scope of delivery — Parallel box

Table 31. Scope of delivery — Extension box

Table 32. Scope of delivery — BMS box/base

Table 33. Scope of delivery — BMS box/split base (optional)

Table 34. Scope of delivery — Battery module

Table 35. Tools required

Table 36. Components for AC connection (not included in the scope of delivery)

Table 37. Description of the switch positions of the maintenance switch (not included in the scope of delivery)

Table 38. Components for AC connection

Table 39. Synchronize to the grid — Jumper between pin 7 and 8

22.2. List of tables

Table 40. Status of the LED ring on the FEMS box

Table 41. Connector — Pin assignment — Power connector

Table 42. Connector — Pin assignment: Control connector

Table 43. LED status displays — Inverter

Table 44. Troubleshooting

Table 45. Information for the operator