



**KACO**   
new energy.

blueplanet 25.0 NX3 M3 WM OD IIG0

blueplanet 30.0 NX3 M3 WM OD IIG0

blueplanet 33.0 NX3 M3 WM OD IIG0

## Manual

- English translation of German original

 **Authorised electrician**  
**Important safety instructions**



Android APP



iOS APP



Installations-Video  
blueplanet 25.0-33.0 NX3

## **Legal provisions**

The information contained in this document is the property of KACO new energy GmbH. Publication, in whole or in part, requires the written permission of KACO new energy GmbH.

## ***KACO warranty***

You can download the current warranty conditions from the Downloads folder on our website at <http://www.kaco-newenergy.com>.

## ***Definitions on product designations***

In this manual, the product “Photovoltaic feed-in inverter” is referred to as the device for ease of reading.

## ***Trademarks***

All trademarks are recognised, even if not explicitly identified as such. A lack of identification does not mean that a product or designation/logo is free of trademarks.

## ***Software***

This device contains open-source software developed by third parties and in some cases licensed under GPL and/or LGPL. More details on this topic and a list of the open-source software used, as well as the corresponding licence texts, can be found on the associated „**KACO Device Manager**“-App in the “Info” menu under “Imprint”, “Wi-Fi Stick Licences” and “Mobile APP Licences”.

## ***Further information***

Here you will find additional information for your devices and system applications.



Application Note  
Dynamic feedin limit and  
blueplanet web public  
without datalogger



Application Note  
Dynamic feedin limit and  
blueplanet web public with  
datalogger



Cloud Registration

---

# Photovoltaic feed-in inverter

## Table of contents

<b>1</b>	<b>General information .....</b>	<b>1</b>	<b>8</b>	<b>Commissioning .....</b>	<b>31</b>
1.1	Notes regarding this document.....	1	8.1	Requirements .....	31
1.2	More information .....	1	8.2	Preconditions relating to standards .....	31
1.3	Layout of Instructions.....	1	<b>9</b>	<b>Configuration and operation .....</b>	<b>32</b>
1.4	Target group .....	2	9.1	Start condition .....	32
1.5	Marking .....	3	9.2	Initial start-up .....	32
<b>2</b>	<b>Safety .....</b>	<b>4</b>	9.3	Authorisation.....	32
2.1	Intended use .....	4	9.4	Operating system and system configuration....	33
2.2	Protection features .....	5	9.5	Signal elements .....	35
<b>3</b>	<b>Description of the device.....</b>	<b>6</b>	9.6	Connecting to the device.....	37
3.1	Mode of operation .....	6	9.7	Menu of the communication device .....	40
3.2	System layout .....	6	9.8	Menu of Inverter .....	47
<b>4</b>	<b>Technical data .....</b>	<b>7</b>	9.9	Service Configuration (Installer).....	49
4.1	Electrical data .....	7	9.10	Performing a Firmware-Update .....	68
4.2	General data .....	8	9.11	Monitoring with “blueplanet web” .....	69
4.3	Environmental data.....	8	9.12	Monitoring with “blueplanet smartcloud” .....	70
4.4	Accessory articles .....	8	9.13	Information on dynamic feed-in.....	71
<b>5</b>	<b>Transportation and Delivery .....</b>	<b>9</b>	<b>10</b>	<b>Maintenance and troubleshooting .....</b>	<b>74</b>
5.1	Scope of delivery .....	9	10.1	Visual inspection.....	74
5.2	Transporting the device .....	9	10.2	Cleaning .....	74
5.3	Installation tool .....	10	10.3	Shutting down for maintenance work / troubleshooting.....	76
<b>6</b>	<b>Assembly and preparation.....</b>	<b>10</b>	10.4	Troubleshooting .....	76
6.1	Choosing the installation location.....	10	10.5	Error code.....	76
6.2	Unpacking the device .....	11	10.6	Fault during connection set-up and search.....	80
6.3	Fastening the mount .....	12	<b>11</b>	<b>Decommissioning and dismantling .....</b>	<b>81</b>
6.4	Installing and securing the device .....	13	11.1	Switching off the device .....	81
<b>7</b>	<b>Installation .....</b>	<b>14</b>	11.2	Disconnecting connections.....	81
7.1	General information .....	14	11.3	Uninstalling the device .....	83
7.2	Surveying the connection area.....	14	11.4	Disassembling the device .....	83
7.3	Making the electrical connection.....	15	11.5	Packaging the device .....	83
7.4	Connecting the device to the power grid.....	15	11.6	Storing the device.....	83
7.5	Connecting the PV generator to the device .....	19	<b>12</b>	<b>Disposal .....</b>	<b>83</b>
7.6	Creating equipotential bonding .....	22	<b>13</b>	<b>Service and warranty.....</b>	<b>84</b>
7.7	Connecting the interfaces .....	23	<b>14</b>	<b>Appendix .....</b>	<b>85</b>
			14.1	EU Declaration of Conformity .....	85

# 1 General information

## 1.1 Notes regarding this document



### WARNING

**Improper handling of the device can be hazardous!**

› You must read and understand the manual in order to install and use the device safely.

### Other applicable documents

During installation, observe all assembly and installation instructions for components and other parts of the system. These instructions also apply to the device, associated components and other parts of the system.

Some of the documents required for the registration and approval of your system are included with the manual.

### Retention of documents

These manual and other documents must be stored near the system and be available at all times.

– The current version of the manual can be downloaded from [www.kaco-newenergy.com](http://www.kaco-newenergy.com).

### English translation of German original

This document has been produced in several languages. The German version is the original version. All other language versions are translations of the original version.





## 1.2 More information

Links to more detailed information can be found at [www.kaco-newenergy.com](http://www.kaco-newenergy.com).

Document title	Document type
Technical data sheet	Product flyer
Dynamic feed-in limitation and blueplanet web with/without data logger	Application Notes
Modbus protocol	KACO legacy protocol (Application Note)
SunSpec information model reference	Application Note
Firmware package	Zip file
Software	Automatisches Update für iOS- / Android-App
EU Declaration of Conformity	Certificates
Country-specific certificates - Certification for specific subassemblies	Certificates

## 1.3 Layout of Instructions

### 1.3.1 Symbols used

	General hazard		Fire and risk of explosion
	Electrical voltage		Risk of burns
	Earthing - ground conductor		

### 1.3.2 Safety warnings symbols guide



#### **DANGER**

**High risk**

Failure to observe this warning will lead directly to serious injuries or even death.



#### **WARNING**

**Potential risk**

Failure to observe this warning may lead to serious injuries or even death.



#### **CAUTION**

**Low-risk hazard**

Failure to observe this warning will lead to minor or moderate injuries.

#### **NOTE**

**Risk of property damage**

Failure to observe this warning will lead to property damage.

### 1.3.3 Additional information symbols



#### **NOTE**

**Useful information and notes**

Information that is important for a specific topic or objective, but that is not safety-relevant.

### 1.3.4 Symbols for instructions

 Prerequisite for use.

1 Perform next step

2 Additional action sequence

» Interim result of the action

» End result

## 1.4 Target group

All activities described in the document may only be carried out by skilled personnel who have the following qualifications:

- Knowledge about how an inverter functions and operates.
- Knowledge of the Modbus specifications
- Knowledge of the SunSpec Modbus specifications
- Training in the handling of hazards and risks during the installation and operation of electrical units and plants.
- Education concerning the installation and start-up of electrical devices and systems.
- Knowledge of applicable standards and directives.
- Knowledge and adherence to this document with all safety notices.

## 1.5 Marking

You will find the name plate with the following data for service and other requirements specific to installation on the right-side panel of the product:

- Product name
- Part number
- Serial number
- Date of manufacture
- Technical details
- Disposal information
- Certification marking, CE marking.

 <b>KACO new energy</b> Werner-von-Siemens-Allee 1 74172 Neckarsulm		blueplanet 30.0 NX3 M3 WM OD IIG0			
		Part number	1002041		
		Serial number	30.0NX312XXXXXX	Year	Q1 / 24
		Barcode: Serial number(Cide128)			
PV Input	Max PV Voltage	1100 V			
	Operating Voltage Range / Start Voltage	180 V - 1000 V / 200 V			
	Mpp Voltage Range at Pnom	450 V - 850 V			
	Max PV Current (Isc)	40 A / 40 A / 40 A			
	Nominal PV Current (Inom)	32 A / 32 A / 32 A			
Grid Port	Nominal Grid Voltage	220 V / 380 V (3/N/PE)			
		230 V / 400 V (3/N/PE)			
		240 V / 415 V (3/N/PE)			
	Nominal Grid Frequency	50 Hz / 60 Hz			
	Frequency Range	45 Hz - 65 Hz			
	Max Grid Output Power	30000 VA			
Max Grid Output Current	47.8 A				
Power Factor Range	0.8 cap - 0.8 ind				
Environ- ment	Temperature Range	- 25 °C - + 60 °C / - 13 °F - + 140 °F			
	Protection Class / Ingress Protection	I / IP 66			
No Galvanic Separation / Ungrounded Arrays Only		Max Backfeed Current	0 A		
Grid Support Interactive Inverter		ARC Fault Circuit Protection	None		
Interface protection according to country specific requirements, details see manual					
					

Fig. 1. Name plate

## 2 Safety

### DANGER

**Lethal voltages are still present in the connections and cables of the device even after the device has been switched off and disconnected!**

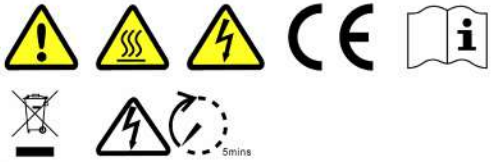
Coming into contact with the lines and/or terminals/busbars in the device can cause serious injury or death.



- › Do not open the device.
- › The device must be mounted in a fixed position before being connected electrically.
- › Comply with all safety regulations and current technical connection specifications of the responsible power supply company.
- › The device is only permitted to be mounted, installed and commissioned by a qualified electrician.
- › Switch off the grid voltage by turning off the external circuit breakers.
- › Do not touch the cables and/or terminals/busbars when switching the device on and off.
- › Check that all AC and DC cables are completely free of current using a clip-on ammeter.

The electrician is responsible for observing all existing standards and regulations. The following points must be taken into account:

- Keep unauthorised persons away from the device and/or system.
- In particular, observe standard<sup>1</sup> “Requirements for special types of premises, rooms and installations – Solar photovoltaic (PV) power supply systems” in the respective regionally applicable version.
- Ensure operational safety by providing proper grounding, conductor dimensioning and appropriate protection against short circuiting.
- Observe all safety instructions on the product and in this manual.
- Switch off all voltage sources and secure them against being inadvertently switched back on before performing visual inspections and maintenance.
- When taking measurements on the live device:
  - Do not touch the electrical connections
  - Remove all jewellery from wrists and fingers
  - Ensure that the testing equipment is in safe operating condition
- Modifications to the surroundings of the device must comply with the applicable national and local standards
- When working on the PV generator, in addition to disconnecting this from the grid it is also necessary to switch off the DC voltage using the DC isolator switch on the device.

### 2.1 Intended use

The device is a transformerless PV inverter which converts the direct current of the PV generator into grid-compatible three-phase alternating current and then feeds the three-phase alternating current into the public power grid.

The device is built using state-of-the-art technology and in accordance with the recognized safety rules. Nevertheless, improper use may cause lethal hazards for the operator or third parties, or may result in damage to the product and other property.

The device is intended for indoor and outdoor applications and may only be used in countries for which it has been approved or for which it has been released by KACO new energy and the grid operator.

Operate the device only with a permanent connection to the public power grid. The country and grid type selection must be commensurate with the respective location and grid type.

The requirements of the grid operator must be met for grid connection to take place. The permission of the relevant authorities may also be required in order to secure authorisation to connection to the grid.

The device may only be operated with PV arrays (PV modules and wiring) of protection class II pursuant to IEC 61730, application class A.

1 Country	Standard
EU	Harmonised document - HD 60364-7-712 (European implementation of the IEC standard)

The enclosed documentation is an integral part of the product. The documentation must be read, observed and stored in a place which is freely accessible at all times.

The name plate must be permanently attached to the product.

Any other or additional use is not considered proper or intended use and can lead to an annulment of the product guarantee. This includes:

- Use of a distribution system that is not described (grid type)
- Use of sources other than PV-strings
- Mobile use
- Use in rooms where there is a risk of explosion
- Use in direct sunlight, rain or a storm or other harsh environmental conditions
- Use in an outdoor area that does not meet the environmental conditions set down in Technical Data > Environmental Data.
- Operation outside the specification intended by the manufacturer
- Overvoltage of over 1100 V on the DC connection.
- Modifying the device
- Standalone mode

## 2.2 Protection features

The following monitoring and protection functions are built-in:

- RCMU (Residual Current Monitoring Unit)
- Overvoltage conductor / varistor to protect the power semiconductors from high-energy transients on the grid and generator sides.
- System for monitoring the device temperature
- EMC filters to protect the inverter from high-frequency grid interference
- Grid-side grounded varistors to protect the product against burst and surge pulses
- Anti-islanding detection according to the current standards.
- Insulation detection / residual current monitoring and shutdown function to detect insulation faults.



### NOTE

If the device is connected, the overvoltage conductors / varistors contained in the device have an impact on the electrical system insulation resistance test as per HD 60364-6 / IEC 60364-6 Low-voltage installations-Part 6: Verification.

IEC 60364-6 6.4.3.3 describes two options for this case. The first option is to disconnect devices with an overvoltage conductor or, if this is not practicable, then the test voltage can be reduced to 250 V.

### 3 Description of the device

#### 3.1 Mode of operation

The device converts the DC voltage generated by the PV-modules into AC voltage and feeds this into the power grid. The starting procedure begins when there is sufficient sunlight and a specific minimum voltage is present in the device. The feed-in process begins once the PV generator has passed the insulation test and the grid parameters are within the requirements imposed by the grid operator for a specific monitoring time. If, as it gets dark, the voltage drops below the minimum voltage value, feed-in mode ends and the device switches off.

#### 3.2 System layout

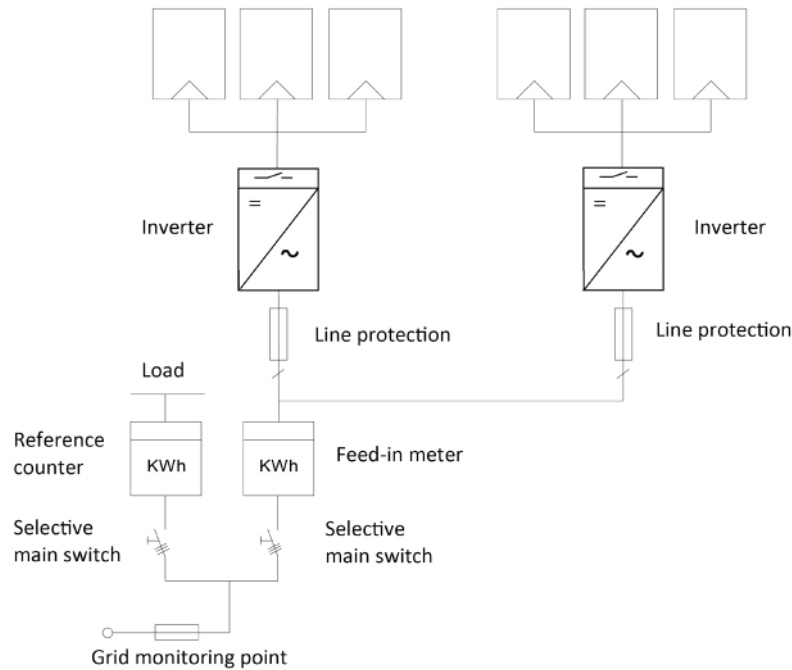

Fig. 2. Circuit diagram of a system with two inverters

Key	Definition / information on the connection
PV generator	The PV generator converts the radiant energy of sunlight into electrical energy.
Inverter with circuit-breaker	The PV generator is connected to the device's DC connection.
Line protection	The circuit breaker is an overcurrent protection device.
Feed-in meter	The feed-in meter is to be specified and installed by the power supply company. Some power supply companies also allow the installation of your own calibrated counters.
Selective main switch	The selective main switch is to be specified by the power supply company.
Reference counter	The reference counter is to be specified and installed by the power supply company. This measures the amount of energy drawn.
Integrated DC isolator switch	Use the integrated DC isolator switch to disconnect the device from the PV generator.

## 4 Technical data

### 4.1 Electrical data

KACO blueplanet	25.0 NX3 M3 WM OD IIGO	30.0 NX3 M3 WM OD IIGO	33.0 NX3 M3 WM OD IIGO
PV Input			
Max Recommended PV Array Power	37500 Wp	45000 Wp	49500 Wp
Mpp Voltage Range at P <sub>nom</sub>	450 – 850 V		
Operating Voltage Range	180 - 1000 V		
Nominal DC Voltage	630 V		
Start Voltage	200 V		
Max PV Voltage	1100 V		
Nominal PV Current (I <sub>nom</sub> ) <sup>1</sup>	32 A (PV1) / 32 A (PV2) / 32 A (PV3)	32 A (PV1) / 32 A (PV2) / 32 A (PV3)	32 A (PV1) / 32 A (PV2) / 40 A (PV3)
Number of strings per MPP controller	2		
Number of MPP controls	3		
Max PV Current (I <sub>sc</sub> ) <sup>2</sup>	40A (PV1) / 40A (PV2) / 40A (PV3)	40A (PV1) / 40A (PV2) / 40A (PV3)	40A (PV1) / 40A (PV2) / 50 A (PV3)
Input source feedback Current	0 A		
Polarity Safeguard	yes		
String fuse	no		
DC overvoltage Protection	Type II		
KACO blueplanet	25.0 NX3 M3 WM OD IIGO	30.0 NX3 M3 WM OD IIGO	33.0 NX3 M3 WM OD IIGO
Grid Port			
Max Grid Output Power	25000 VA	30000 VA	33000 VA
Nominal Grid Voltage	220 / 380 V [3/N/PE]; 230 / 400 V [3/N/PE]; 240 / 415 V [3/N/PE]		
Grid Voltage Range	160 – 300 V		
Rated Current @ 220 / 380 V	37.9 A	45.5 A	50.0 A
Rated Current @ 230 / 400 V	36.2 A	43.5 A	47.8 A
Rated Current @ 240 / 415 V	34.8 A	41.7 A	45.9 A
Max Grid Output Current	39.9 A	47.8 A	52.6 A
Contribution to peak short-circuit current ip	110 A	110 A	135 A
Initial short-circuit alternating current (Ik" first single period effective value)	39.9 A	47.8 A	52.6 A
Short-circuit current continuous (Ik. max output fault current)	39.9 A	47.8 A	52.6 A
Inrush Current	<20 % of the rated AC current for a maximum of 20 ms		
Nominal Grid Frequency	50 / 60 Hz		
Frequency Range	45 – 65 Hz		
Reactive Power	0 – 60 % S <sub>nom</sub>		
Power Factor Range	0.8 <sub>cap</sub> – 0.8 <sub>ind</sub>		
Number of feed-in phases	3		
Harmonics THD	< 3 %		
Max. Voltage Range (up to 100 s)	305 V (Phase - Neutral)		
AC Overvoltage Protection	Type II		

<sup>1</sup> The “Nominal PV Current (I<sub>nom</sub>)” the maximal theoretical value for operation with full power when the feed-in power is low. The device is limited to the maximum AC power.

<sup>2</sup> The “Max PV Current (I<sub>sc</sub>)” together with the open circuit voltage (U<sub>OCmax</sub>) defines the characteristic of the connected PV generator. This is the relevant value for string design and represents the absolute maximum limit for inverter protection. The connected PV generator must be designed in such a way that the maximum short-circuit current is less than or equal to the I<sub>SCmax</sub> of the inverter under all foreseeable conditions. The design must in no case result in a short-circuit current greater than the I<sub>SCmax</sub> of the inverter.

## 4.2 General data

KACO blueplanet	25.0 NX3 M3 WM OD IIG0	30.0 NX3 M3 WM OD IIG0	33.0 NX3 M3 WM OD IIG0
Max. Efficiency	97.36 %	97.66 %	97.94 %
Europe. Efficiency	97.15 %	97.38 %	97.54 %
Self consumption: Standby	< 1 W		
Feed-in from	60W		
Transformer unit	no		
Protection class / over voltage category	I / III (AC) II (DC)		
Grid monitoring	Country-specific		
Distribution system	TN-C system, TN-C-S system, TN-S system, TT system		
Display	LEDs		
Controls	APP		
Menu languages	EN; DE		
Interfaces	USB(Connect-NX), RS485 (Smart meter / Datalogger), RJ45 (Ripple control receiver/ NA-Protection device)		
Communication	WiFi, LAN, Ethernet, Modbus TCP-IP in accordance with SunSpec / Sunspec Modbus RTU, KACO Legacy Protocol		
Radio technology	WLAN 802.11 b / g / n		
Frequency spectrum	2,412 MHz – 2,472 MHz		
Antenna gain	2dBi		
Potential-free relay	no		
DC isolator switch	yes		
AC isolator switch	no		
Cooling	Air cooling		
Number of fans	3x outside, 1x inside		
Noise emission	< 50 dB(A)		
Housing material	AL		
H x W x D	600 mm x 573,5 mm x 251 mm		
Weight	30,5 kg	30,5 kg	32,4 kg
Interference immunity / interference Emission / grid feedback	EN 61000-6-1, EN 61000-6-2, EN 62920 - Class A / EN 61000-6-3, EN 61000-6-4, EN 62920 - Class B, EN 55011 - group 1 Class B /EN 61000-3-11, EN 61000-3-12		
Certifications	Overview: see homepage, download area		

## 4.3 Environmental data

KACO blueplanet	25.0 NX3 M3 WM OD IIG0	30.0 NX3 M3 WM OD IIG0	33.0 NX3 M3 WM OD IIG0
Installation Height	3000 m		
Installation distance from coast	> 500 m		
Ambient Temperature	- 25 °C – + 60 °C		
Ambient Temperature (storage)	- 25 °C – + 60 °C		
Power derating from	> 45 °C		
Protection rating (KACO installation loc.)	IP 66 / NEMA 4X		
Humidity Range (non-condensing) [%]	100 %		
Pollution level inside the enclosure	2 (reduced by IP 66 Housing)		
Pollution level outside the enclosure	3		





## 4.4 Accessory articles

Accessory articles	KACO order no.
Eastron SDM630	3015600

## 5 Transportation and Delivery

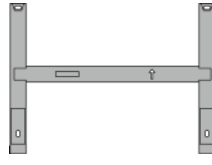
Every product leaves our factory in perfect electrical and mechanical condition. Special packaging ensures that the devices are transported safely. The shipping company is responsible for any transport damage that occurs.

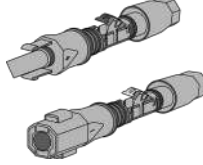
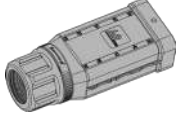
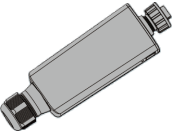
### 5.1 Scope of delivery

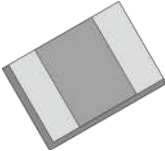
				
A	B	C	D	E
				
F	G	H		

Article	Description	Quantity
A	Inverter	1 piece
B	Wall mounting bracket	1 piece
C	Mounting accessory kit: Wall fixings and hex bolts (4×) M5×14 mm screw (2×)	1 set
D	DC connector (Phoenix Sunclix)	6 pairs
E	AC connector cover	1 piece
F	Communication device (Connect-NX GEN2)	1 piece
G	RJ45 Connection waterproof housing	4 pcs
H	Documentation	1 set

#### Check the equipment included

- Inspect the device thoroughly.
- Immediately notify the shipping company in case of the following:
  - o Damage to the packaging that indicates that the device may have been damaged.
  - o Obvious damage to the device.
- Send a damage report to the shipping company immediately.
- The damage report must be received by the shipping company in writing within six days following receipt of the device. We will be glad to help you if necessary.

### 5.2 Transporting the device

#### CAUTION



#### Hazard due to impact; risk of breakage to the device!

- › Pack the device securely for transport.
- › Transport the device using the intended carrying handles of the packaging box.
- › Do not expose the device to any shocks.

For safe transportation of the product, use the hand recesses in the carton.

Packaging	Folding cardboard box
Height x width x depth	680 x 610 x 330
Total weight	37,5 – 39,4 kg

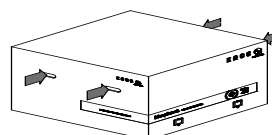

## 5.3 Installation tool

The codes given in the table below are used in all usage instructions for assembly/installation/maintenance and disassembly for the tools and tightening torques being used.

Code (s)	Shape of the connector
XW	External hexagon
XA	Allen wrench
XT	Torx
XS	Slot
XP	Phillips

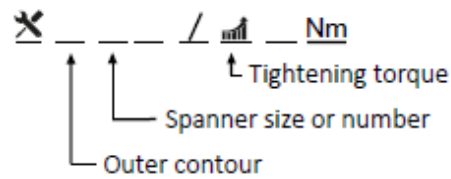

Fig. 3. Form pattern

## 6 Assembly and preparation

### 6.1 Choosing the installation location

#### DANGER



##### **Risk of fatal injury due to fire or explosions!**

Fire caused by flammable or explosive materials in the vicinity of the device can lead to serious injuries.

- Do not mount the inverter in an area at risk of explosion or in the vicinity of highly flammable materials

#### CAUTION



##### **Property damage due to gases that have an abrasive effect on surfaces when they come into contact with ambient humidity caused by weather conditions.**

The device housing can be seriously damaged due to gases in combination with air humidity resulting from weather conditions (e.g. ammonia, sulphur).

- If the device is exposed to gases, the installation must be carried out at observable locations.
- Perform regular visual inspections.
- Immediately remove any moisture from the housing.
- Ensure adequate ventilation at the installation location.
- Immediately remove dirt, especially on vents.
- Failure to follow these warnings may result in damage to the device that is not covered by the manufacturer's warranty.



#### NOTE

##### **Access by maintenance personnel for service**

Any additional costs arising from unfavourable structural or installation conditions will be billed to the customer.

#### Installation space

- As dry as possible, climate-controlled. The waste heat must be dissipated away from the device
- Unobstructed air circulation
- When installing the device in a control cabinet, provide forced ventilation for sufficient heat dissipation
- Close to the ground, accessible from the front and sides without requiring additional resources
- In outdoor areas, protected on all sides from direct weather exposure and sunlight (thermal heating). Implementation where necessary via constructional measures, e.g. wind breaks
- Make sure that the inverter is installed out of the reach of children.
- To ensure an optimal operation and a long service life, the temperature of the installation environment of the inverter should be  $\leq 45$  °C.
- To avoid direct sunlight, rain, snow and puddling on the inverter, we recommend to install the inverter at locations with a protective roof. Do not completely cover the top of the inverter.
- The installation conditions must be able to accommodate the weight and size of the inverter. The inverter is suitable for mounting on a solid wall that is vertical or sloping backwards (max. 15°). It is not recommended to install the inverter on a wall made of plasterboard or similar materials. The inverter may emit audible noises during operation.

#### Installation surface

- Must have adequate load-bearing capacity

- Must be accessible for installation and maintenance
- Must be made of heat-resistant material (up to 90 °C)
- Must be flame resistant
- Minimum clearances to be observed during installation: [See Fig. 9 on Page 12]

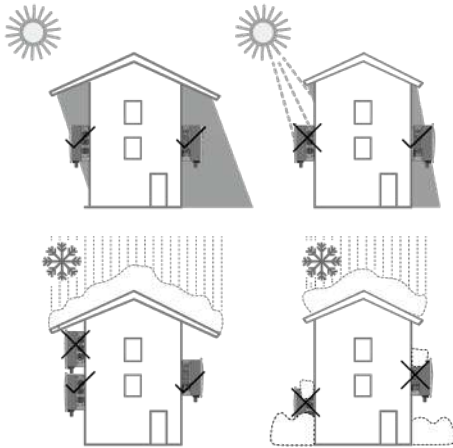

Fig. 4. Device for outdoor installation

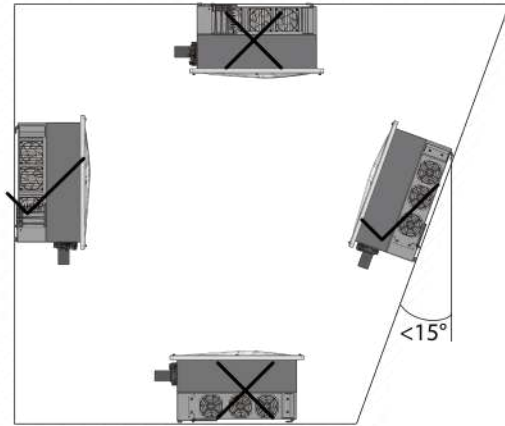

Fig. 5. Permissible installation location

## 6.2 Unpacking the device



### ⚠ CAUTION

#### Risk of injury due to excessive physical strain

Lifting the device, for transport, relocation and assembly can result in injuries (e.g. back injuries).

- › Always lift the device using the openings provided
- › The device must be transported and installed by at least 2 persons

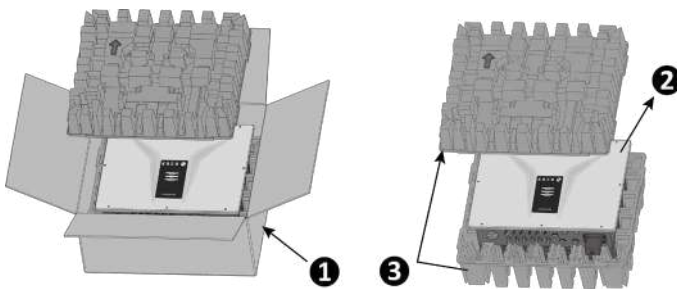

Fig. 6. Unpacking the device



Fig. 7. Lift the unit

#### Key

1	Packaging box	3	Protective packaging
2	Device	4	Lifting positions

🔄 The device has been transported to the installation site.

1. Loosen packaging tape from cardboard box.
2. Open carton at the front.
3. Remove installation material and documentation.
4. Pull up top protective packaging to remove.
5. Remove device from the packaging, take hold of the cover and lift it out of the packaging.
6. Place the protective packaging back into the packaging box.
7. Lift the device at the intended positions (see Fig. 7).

» Proceed with the installation of the mount

## 6.3 Fastening the mount



### CAUTION

#### Hazard when using unsuitable fixing materials!

If unsuitable fixing materials are used, the device could fall and persons in front of the device may be seriously injured.

- › Use only fixing materials that are suitable for the mounting base. The fastening materials supplied are only suitable for masonry and concrete.
- › Only install the device in an upright position.

### NOTE



#### Power reduction due to heat accumulation!

If the recommended minimum clearances are not observed, the device may go into power regulation mode due to insufficient ventilation and the resulting heat build-up.

- › Observe minimum clearances and provide for sufficient heat dissipation.
- › All objects on the device housing must be removed during operation.
- › Ensure that no foreign bodies prevent heat dissipation following device installation.

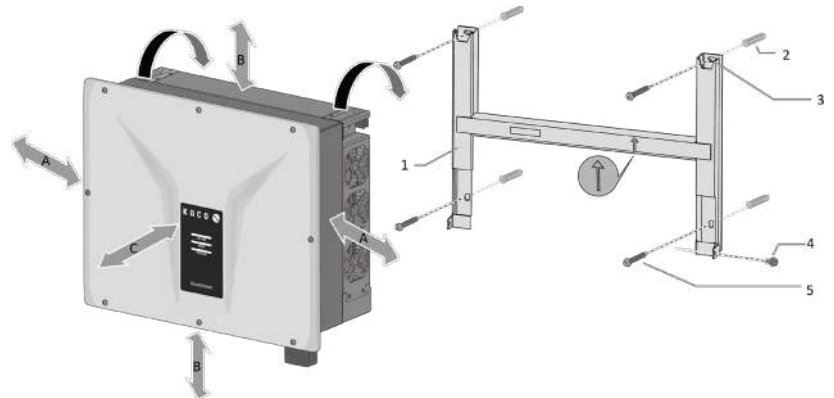
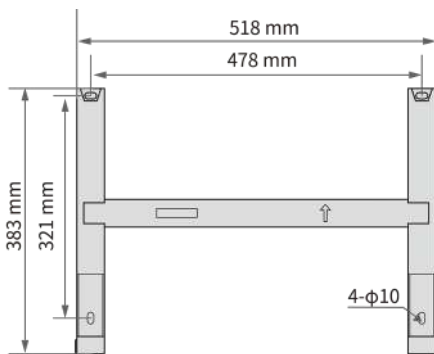

Fig. 8. Drill holes for wall mounting

Fig. 9. Mounting the wall bracket

#### Key

1 Mount	5 Screw for mounting (4x)
2 Fastening anchors [Mounting hole size: $\varnothing$ 12 mm depth 70 mm ]	A Minimum clearance: 500 mm
3 Mounting ears	B Minimum clearance: 500 mm
4 Screw for securing purposes (2x)	C Recommended clearance: 500 mm

🔄 Cardboard packaging with mount and mounting kit removed from the packaging and opened.

1. Mark the mounting position on the wall surface according to the position of the mount by drawing a line.

**NOTE: The arrow must be pointing upwards and be visible when the mount is fastened to the wall. And make sure that the mount is oriented correctly.**

2. Mark the positions of the drill holes using the slot in the mount.

**NOTE: Make sure that the mount is oriented correctly.**

3. Fix the mount to the wall using suitable mounting fixtures from the mounting kit [XW-10].

» Proceed with the installation of the device.

## 6.4 Installing and securing the device

### CAUTION



#### Risk of injury from improper lifting and transport.

If the device is lifted improperly, it can tilt and result in a fall.

- › Always lift the device vertically using the openings provided.
- › Use a climbing aid for the chosen installation height.
- › Wear protective gloves and safety shoes when lifting and lowering the device.

### Lifting and installing the device

 The mount has been installed.

1. Lift the device using the grip recesses (see Fig. 7). Observe the centre of gravity!

2. Fit the device onto the mounting bracket. Check both sides of the heat sink to ensure that it is securely in place. (see Fig. 11).

3. Insert the screw provided into the lug of the mount and secure the device to prevent it from being lifted off (see Fig. 12). [ 2.5 Nm]

**NOTE: At this point, the screw described above can be replaced by a special screw as anti-theft protection.**

»Device is installed. Proceed with the electrical installation.

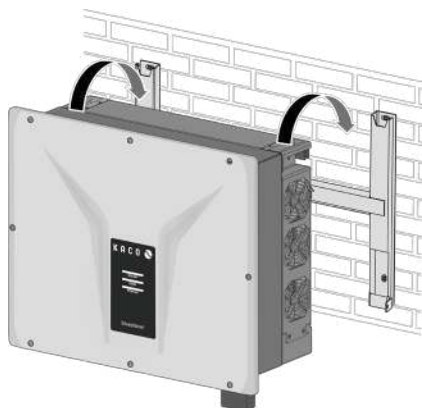

Fig. 10. Mount the inverter on the wall bracket

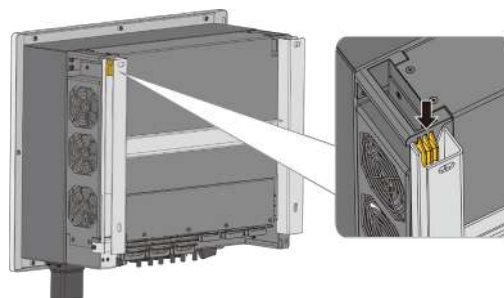

Fig. 11. Check that the device is secure

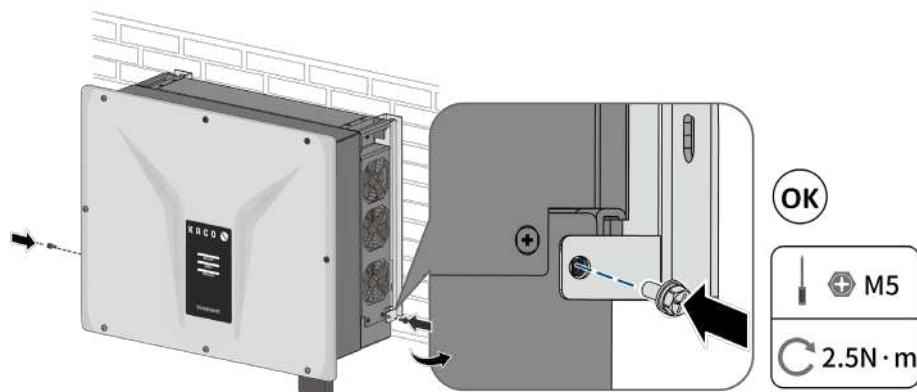

Fig. 12. Secure the inverter

**⚠ CAUTION**

**Property damage as a result of condensation**



During pre-assembly of the device, moisture can enter the internal space via the DC connectors and the dust-proof screw connections. The resulting condensate can cause damage to the device during installation and start-up.

- Keep the device closed during pre-assembly and do not open the connection area until you perform installation.
- Seal off any plug-in connections and screw fittings using sealing covers.
- Immediately remove any moisture from the housing.

## 7 Installation

### 7.1 General information

**⚠ DANGER**



**Lethal voltages are still present in the connections and cables of the device even after the device has been switched off and disconnected!**

Coming into contact with the lines and/or terminals/busbars in the device can cause serious injury or death.

- › Do not open the device.
- › The device must be mounted in a fixed position before being connected electrically.
- › Comply with all safety regulations and current technical connection specifications of the responsible power supply company.
- › Switch off the grid voltage by turning off the external circuit breakers.
- › Check that all AC and DC cables are completely free of current using a clip-on ammeter.
- › Do not touch the cables and/or terminals/busbars when switching the device on and off.

### 7.2 Surveying the connection area

The connection for the AC supply is located on the housing in the lower right area. The DC input source is connected to the DC plugs and DC sockets on the base plate.

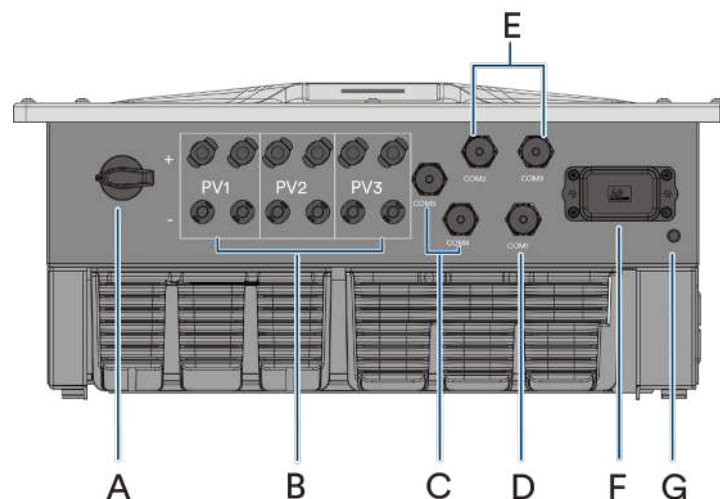

Fig. 13. Connection area on DC side (left) / AC/COM side (right)

**Key**

A	DC integrated isolator switch	E	COM 2 & 3 - RJ45 socket for RS485 connection
B	DC connector for PV generator	F	AC connection socket
C	COM 4&5 - Connection of Ripple control receiver /NA protection device	G	The position of the equipotential bonding
D	COM 1 - Connector for Communication device (KACO Connect-NX GEN2)		

## 7.3 Making the electrical connection



### NOTE

Select conductor cross-section, safety type and safety value in accordance with the following basic conditions:

Country-specific installation standards; power rating of the device; cable length; type of cable installation; local temperature

### 7.3.1 Requirement for supply lines and fuse

PV-side	
Max conductor cross-section	6 mm <sup>2</sup> (copper)*
Min conductor cross-section	2.5 mm <sup>2</sup> (copper)*
Connection type (brand and model for connector)*	PC SUNCLIX PV-C3F-S 2,5-6mm <sup>2</sup> max. 20 A at (+) PV-FT-C4M-HSG (Device) PC SUNCLIX PV-C3M-S 2,5-6mm <sup>2</sup> max. 20 A at (-) PV-FT-C4F-HSG (Device)
Recommended cable type	Solar cable (max. 20 A)
AC-side	
Max cable diameter	36 mm
Min cable diameter	20 mm
Length of cable jacket to be stripped off	100 mm
Max. conductor cross-section	25 mm <sup>2</sup>
Min. conductor cross-section	10 mm <sup>2</sup>
Length of conductor insulation to be stripped off	20 mm
Tightening torque	5 Nm
Connector type	Core end terminal
Additional ground wire	
Max. conductor cross-section for additional ground conductor connection	25mm <sup>2</sup> (copper)
Min. conductor cross-section for additional ground conductor connection	10mm <sup>2</sup> (copper)
Colour of cable	Yellow - green
Interfaces	
RS485 connection type	Twisted pair cable with shield
Terminal conductor cross-section	0.2 – 0.5 mm <sup>2</sup>
Ethernet cable type	Category 5
RCR & NS Protection connection type	RJ45
RCR&NS Protection cable type	Category 5

\* As an alternative to the DC solar plugs included in the scope of delivery, the following Phoenix Contact plugs may also be used:

Connection type (brand and model for connector)	PC SUNCLIX PV-C4F-S 6-16 mm <sup>2</sup> max. 20 A at (+) PV-FT-C4M-HSG (Device) PC SUNCLIX PV-C4M-S 6-16mm <sup>2</sup> max. 20 A at (-) PV-FT-C4F-HSG (Device)
---	---

When using these plugs in combination with a 16 mm<sup>2</sup> cable, a suitable current limitation must be ensured. The plugs mentioned are not included in the scope of delivery and must be procured by the customer himself.

## 7.4 Connecting the device to the power grid



### NOTE

If local regulations require the use of a residual-current device, please install a type A residual-current protection device.



### NOTE

For the TT grid structure, the effective value of the voltage between the neutral wire and the ground wire must be less than 20V.

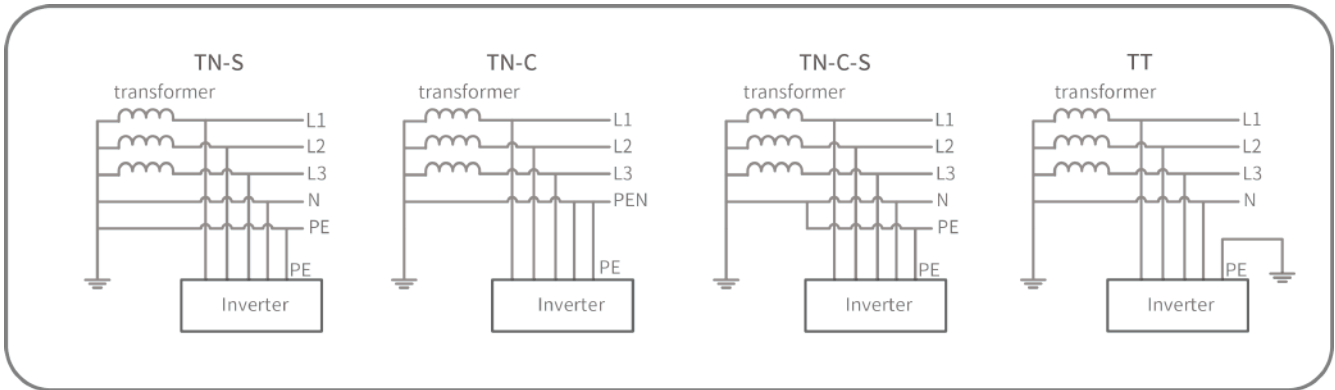

### 7.4.1 Prepare the grid connection

- ⌚ A connection cable with 5 wires is provided.
- ⌚ Nominal grid voltage matches the VAC nom name plate details.

1. Remove the plastic AC cover from the inverter. (see Fig. 14)
2. Unfasten the cable fitting for AC connection (see Fig. 15).
3. Guide the AC leads through the cable fittings.
  - **NOTE! When the cable outer diameter D is greater than 24mm, remove the sealing ring.**
5. Strip the insulation from the AC cables.
6. Strip the insulation from individual wires for L1 / L2 / L3 / N and PE (ground) so that the strand and insulation can be pressed into core end terminal (see Fig. 16). The PE conductor must be 5 mm longer than the L and N conductors.
  - **CAUTION! Risk of fire due to chemical corrosion. Cable lugs must be suitable for the conductor material and copper busbars being used.**
  - **WARNING! Risk of short circuit due to incorrect size of the cable lug! Observe the dimensions for the selection.**
7. Insert the copper wire into a suitable terminal and crimp it.(see Fig. 17) .

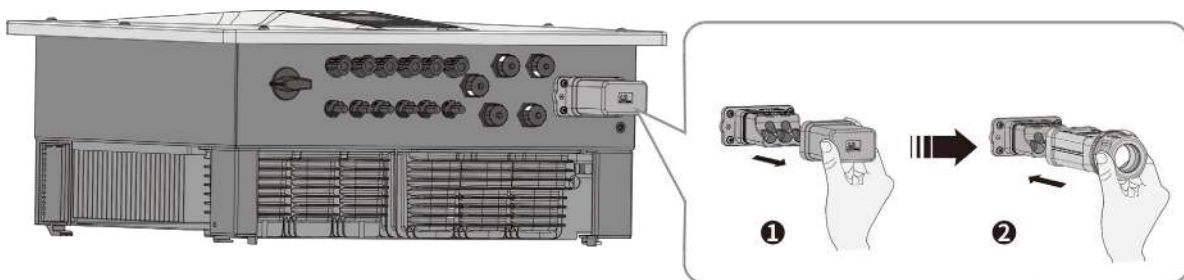

Fig. 14. Remove the plastic AC cover

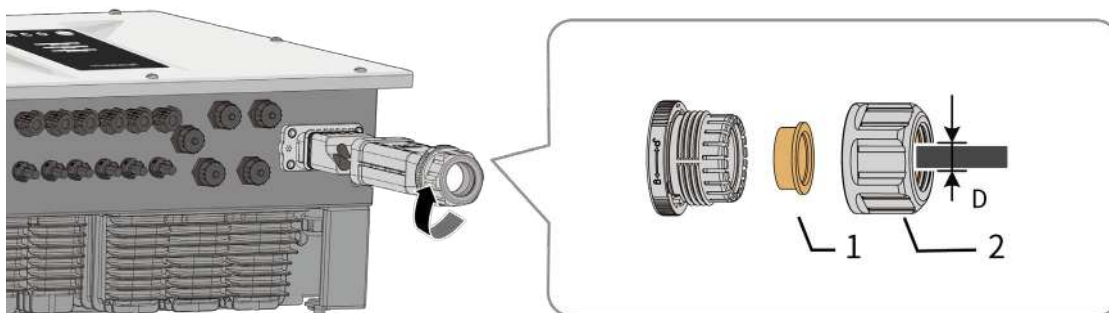

Fig. 15. Unfasten AC cable fitting

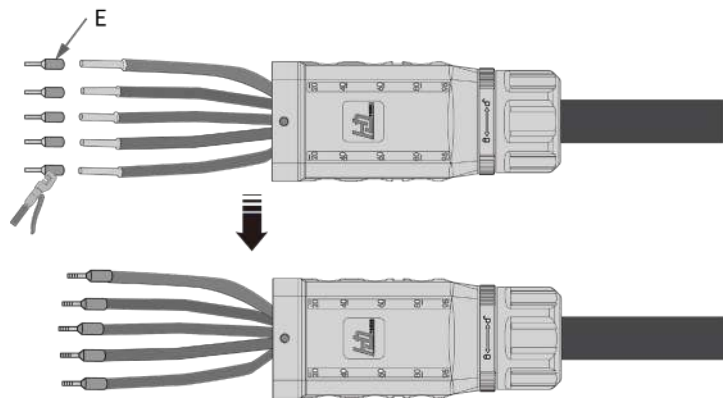
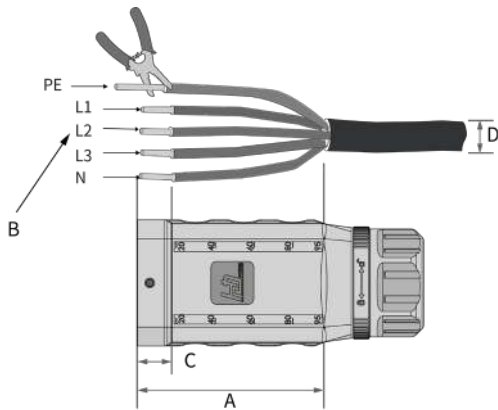

Fig. 16. AC leads through the cable and strip the insulation from the AC cables

Fig. 17. Make the cable and crimp core end termina

**Key**

1	Sealing ring	C	Stripping length of the insulated conductors (matching core end terminal)
2	Nut	D	Outer diameter (20 to 36 mm)
A	Length of cable jacket to be stripped off (approx. 95-100mm)	E	Core end terminal
B	Conductor cross-section (10 to 25 mm <sup>2</sup> )		

### 7.4.2 Make AC connection

⌚ AC cable have been prepared.

1. Switch off the AC circuit breaker and lock it to avoid it from being inadvertently switched on(see Fig. 18).
2. Insert the wires into the connector according to the line sequence [Figure 17], checking that the wires are correctly positioned by means of the viewing hole. Then tighten the screws on the contact carrier [ $\times A_3$  /  $\text{3.0 Nm}$ ].
3. Slide the cover over the connector in such a way that the hole and the logo of the cover are visible (see Fig. 19).

**NOTE: The AC connection is secure when an audible click is heard.**

4. Tighten the nut with an open-ended wrench and complete the installation with a “click, click” [ $\times W_{50}$  /  $\text{10.0 Nm}$ ] (see Fig. 20)
5. Once the nut is screwed in completely, the retaining ring can be turned to secure the nut.
6. Lay the cables correctly and in accordance with the following rules:
  - Lay the cables around the device with a minimum clearance of 30 cm.
  - Never lay cables over semiconductors (cooling bodies).
  - Excessive bending force may negatively impact the protection rating. Lay the cables with a bending radius of at least 4 times the cable diameter.

»The device is connected to the power grid.

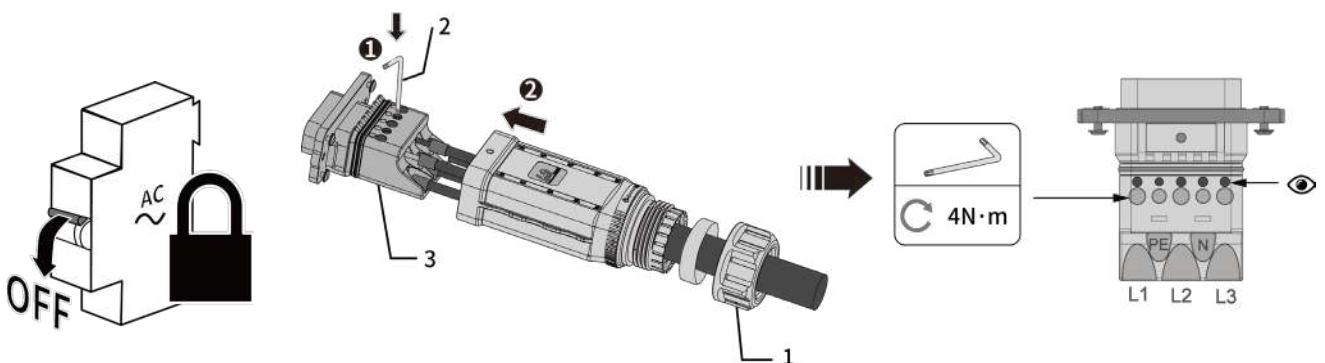

Fig. 18. Switch off the AC circuit breaker.

Fig. 19. Connect wires to contact carrier and tighten housing screws

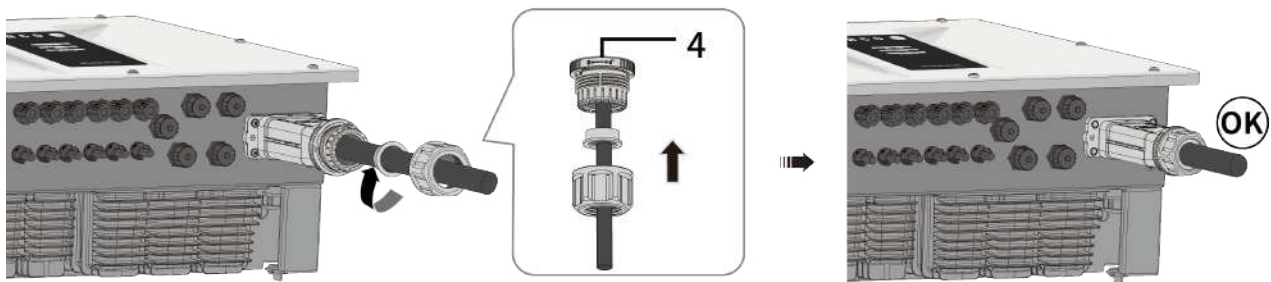

Fig. 20. Attach the AC cover and tighten the nut.

Key

1	Nut	3	Connector
2	Allen key	4	Retaining ring



#### NOTE

An AC-side disconnection unit must be provided during the final installation stage. This disconnector mechanism must be installed so that it can be accessed at any time without obstruction.



#### NOTE

If a residual current device (RCD) is necessary due to the installation specification, a Type A RCD device should be used.

For questions regarding the appropriate type, please contact the installer or our KACO new energy customer service.



#### NOTE

When the line resistance is high, i.e. long cables on the grid side, the voltage at the grid terminals of the device will increase in feed-in mode. If the voltage exceeds the country-specific grid overvoltage limit value, the device switches off.

Ensure that the cable cross-sections are sufficiently large or that the cable lengths are sufficiently short.

## 7.5 Connecting the PV generator to the device

### 7.5.1 Configuring the DC connector

 **DANGER**

**Risk of fatal injury due to electric shock!**

Coming into contact with live connections can cause serious injury or death. When there is sunlight present on the PV generator, there is DC voltage on the open ends of the DC cables.



- › Make sure that PV modules have good insulation against ground.
- › On the coldest day based on statistical records, the max. open-circuit voltage of the PV modules must not exceed the max. input voltage of the inverter.
- › Check the polarity of DC cables.
- › Ensure that the device is completely free of DC voltage.
- › Do not disconnect DC connectors under load.

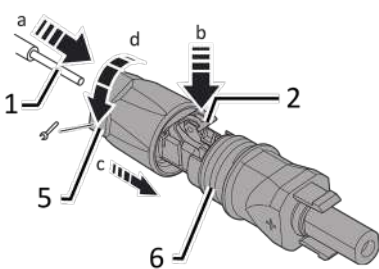

Fig. 21. Insert wires

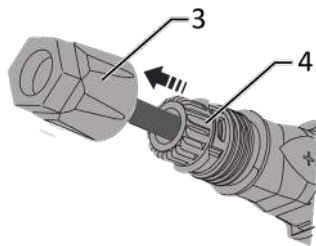

Fig. 22. Slide insert into sleeve

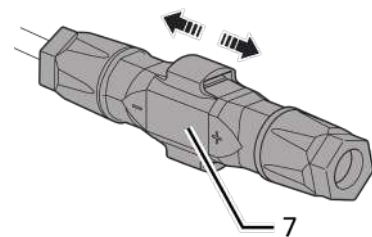



Fig. 23. Check fastening

**Key**

1	Wire for DC connection	5	Cable fitting
2	Spring	6	Contact plug
3	Insert	7	Coupling
4	Sleeve		

 You have completed assembly.

 **NOTE: Before proceeding with the isolation ensure that you do not cut any individual wires.**

1. Insert isolated wires with twisted ends carefully up to the connection.

**NOTE: Wire ends must be visible in the spring.**

2. Close the spring so that the spring latches and slide insert into sleeve.

3. Secure and tighten the cable fitting [ $\times W_{15}$  /  $\triangle 1.8$  Nm].

4. Join insert with contact plug.

5. Check latch by lightly pulling on the coupling.

› Make the electrical connections

**NOTE**



**The permissible bending radius of at least 4x the cable diameter should be observed during installation.**

**Excessive bending force may negatively impact the protection rating.**

- › All mechanical loads must be absorbed in front of the plug connection.
- › Rigid adaptations are not permitted on DC plug connectors.

## 7.5.2 Checking the PV generator for a ground fault



### **⚠ DANGER**

#### **Risk of fatal injury due to electric shock!**

Coming into contact with live connections can cause serious injury or death. When there is sunlight present on the PV generator, there is DC voltage on the open ends of the DC cables.

- › Only touch the PV generator cables on the insulation. Do not touch the exposed ends of the cables.
- › Avoid short circuits.
- › Do not connect any strings with a ground fault to the device.



### **NOTE**

The threshold value above which the insulation monitor reports an error can be set on the mobile device under Other protection settings - Minimum insulation resistance.

#### **Ensure that there is no ground fault**

- 1 Measure the DC voltage between the protective earth (PE) and the positive cable of the PV generator.
- 2 Measure the DC voltage between the protective earth (PE) and the negative cable of the PV generator.
  - › If stable voltages can be measured, there is a ground fault in the DC generator or its wiring. The ratio between the measured voltages gives an indication as to the location of this error.
- 3 Rectify any errors before taking further measurements.
- 4 Measure the electrical resistance between the protective earth (PE) and the positive cable of the PV generator.
- 5 Measure the electrical resistance between the protective earth (PE) and the negative cable of the PV generator.
  - › In addition, ensure that the PV generator has a total insulation of more than 2.0 MOhm, since the device will not feed in if the insulation resistance is too low.
- 6 Rectify any errors before connecting the DC generator.

## 7.5.3 Recommended standard connection

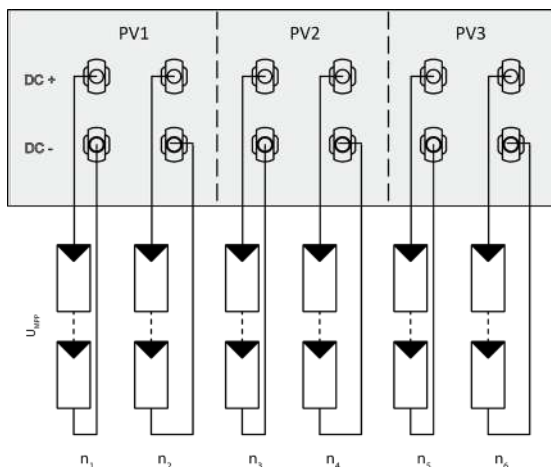

Fig. 24. Assignment of all MPP trackers

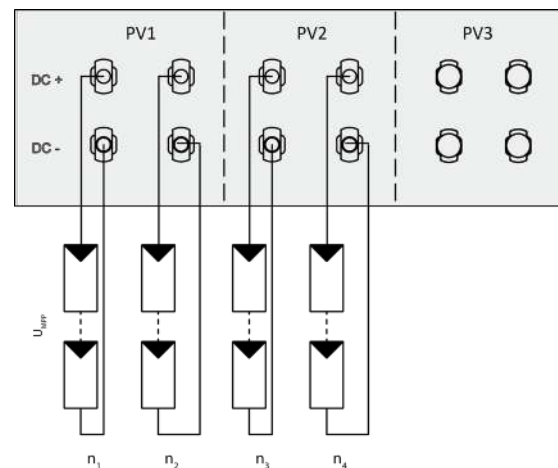

Fig. 25. Assignment of only two MPP trackers

Possible connection of MPP trackers PV1, PV2 and PV3

Two DC strings for **each** MPP tracker

The MPP voltages for each MPP tracker can be different. They are supplied by separate, independently operating MPP trackers (MPP trackers PV1, PV2 and PV3).

Number of modules per string:

$P_{max}$ : per string  $< 0.6 \cdot \text{max. recommended PV generator power}$

MPP tracker A+B+C together  $< \text{max. recommended PV generator power}$

$I_{max}$ : per tracker  $< \text{max. rated current (DC)}$

Two DC strings to two MPP trackers

If one of the MPP trackers is not used, only the unused DC connectors need to be closed.

It is irrelevant whether PV1+PV2 or PV2+PV3 is used.

$P_{max}$ : per string  $< 0.6 \cdot \text{max. recommended PV generator power on the MPP tracker used}$   $< \text{max. power per MPP tracker}$

The input current from Chapter 4 on page 7 is different for each MPP tracker and must not be exceeded. Therefore, pay close attention to whether this value applies to PV1, PV2 or PV3.

### 7.5.4 Designing the PV generator



#### CAUTION

##### **Damage to components due to faulty configuration!**

In the expected temperature range of the PV generator the values for the no-load-voltage and the short circuit current must never exceed the values for  $U_{dcmax}$  and  $I_{scmax}$  in accordance with the technical data.

- › Observe limit values in accordance with the technical data.



#### NOTE

##### **Type and configuration of the PV modules**

Connected PV modules must be dimensioned for the DC system voltage in accordance with IEC 61730 Class A, but at least for the value of the AC grid voltage.



#### NOTE

##### **Dimensioning the PV generator**

The device is designed with a reserve of DC short-circuit current resistance. This allows for oversizing of the connected PV generator. The absolute limit for the PV generator is the value of the max. short-circuit current ( $I_{sc\ max}$ ) and the max. no-load voltage ( $U_{oc\ max}$ ).

### 7.5.5 PV generator

#### DANGER



##### **Risk of fatal injury due to electric shock!**

Coming into contact with live connections can cause serious injury or death. When there is sunlight present on the PV generator, there is DC voltage on the open ends of the DC cables.

- › Only touch the PV generator cables on the insulation. Do not touch the exposed ends of the cables.
- › Avoid short circuits.
- › Do not connect any strings with a ground fault to the device.

#### CAUTION



##### **Damage to the PV generator in case of faulty configuration of the DC connector**

Incorrect configuration of the DC connector (polarity +/-) leads to device damage in the DC connection if it is connected permanently.

- › Please check polarity (+/-) of the DC connector before connecting the PV generator.
- › Before using the solar modules, check the vendor's calculated voltage values against those actually measured. The DC voltage of the PV system must not exceed the maximum no-load voltage at any time.

## Connecting the PV generator

⌚ The DC plug connector has to be configured and PV generator checked to ensure there is no ground fault.

**NOTE:** Note the different current-carrying capacity of PV1, PV2 and PV3 depending on the power class of the device. See technical data – Chapter 4.1 on page 7  
PV1 = (1); PV2 = (2); PV3 = (3).

1. Connect the DC plug connectors to the DC positive and DC negative connectors in pairs.

» The device is connected to the PV generator.

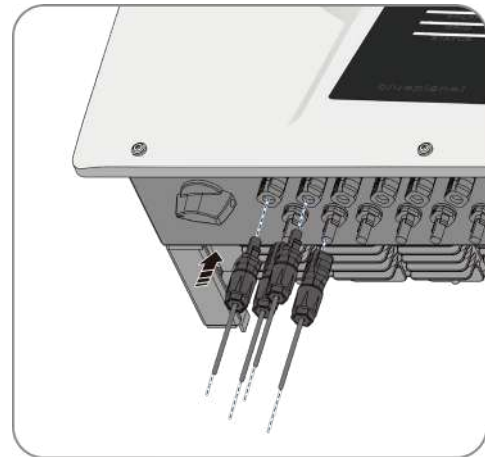

Fig. 26. Current-carrying capacity and plug in PV connector

## Closing the unused DC connectors

⌚ All existing strings are connected to the device.

**NOTE:** Meet the requirements of protection class IP66 by closing the unused plug connectors with the enclosed protective caps.

1 Press down the clamping bracket and push the forcing nut up to the thread. Insert the sealing plug into the DC plug connector and tighten the forcing nut.

2 Finally, insert DC plug connectors with sealing plugs into the corresponding DC input terminals on the device.

» Unused DC plug connectors are closed.

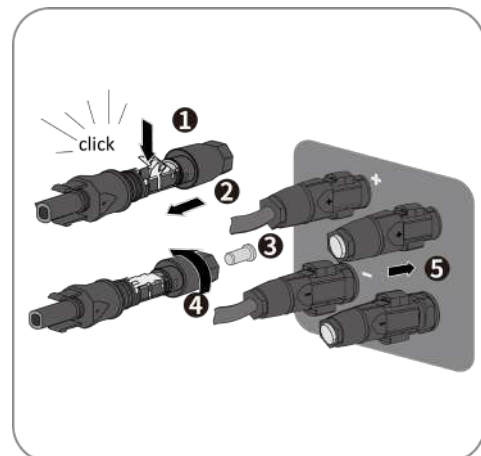

Fig. 27. Insert DC plug connectors and close unused connectors

## 7.6 Creating equipotential bonding



### NOTE

Depending on the local installation specifications, it may be necessary to earth the device with a second ground connection. To this end, the threaded bolt on the underside of the device can be used.

⌚ The device has been installed on the mount.

1. Insert the grounding conductor into the suitable terminal lug and crimp the contact.

2. Align the terminal lug with the grounding conductor on the screw.

3. Tighten the screw tightly into the housing [ P\_5/ 2.5 Nm].

» The housing is included in the equipotential bonding

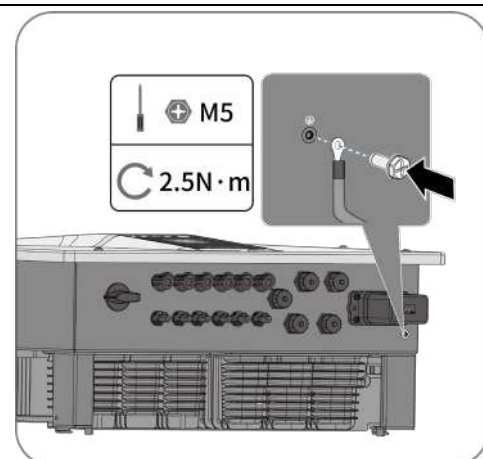

Fig. 28. Connect the grounding



### NOTE

Depending on the local installation specifications, it may be necessary to earth the device with a second ground connection. To this end, the threaded bolt on the underside of the device can be used.

## 7.7 Connecting the interfaces

### 7.7.1 Connect the Communication device

#### CAUTION



#### Damage to the inverter due to electrostatic discharge

Components inside the inverter can be damaged beyond repair by electrostatic discharge.  
 › Earth yourself before touching the components.

#### CAUTION



#### Damage to the Communication device due to rotation of the module housing

When the Communication device is attached to the inverter, the nut on the Communication device must be turned. The Communication device can be damaged if you rotate the housing of the Communication device.  
 › Do not rotate the housing of the Communication device when attaching it to the device.



### HINWEIS

#### Positioning the Communication device

The communication device can be connected to any inverter in the Modbus chain. However, to ensure a reliable link to your router, always choose the inverter position with the strongest Wi-Fi signal:  
 › Insert the communication unit into the inverter that receives the strongest Wi-Fi signal from your router. Once inserted, the Modbus addresses of the downstream inverters will be assigned automatically, starting from address 3.

The device has been installed on the mount.

1. Remove the cap on the COM1 connector (see Fig. 29).
2. Insert the Communication device into the existing connection and screw it tightly into the connection using the nut on the Communication device (see Fig. 30).

**NOTE: Do not rotate the housing of the communication device when attaching it to the device.**

3. Ensure that the Communication device is securely connected and the label on the device can be seen.  
 › The Communication device is connected to the device.

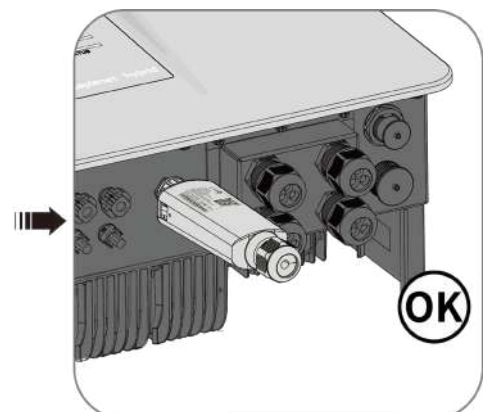
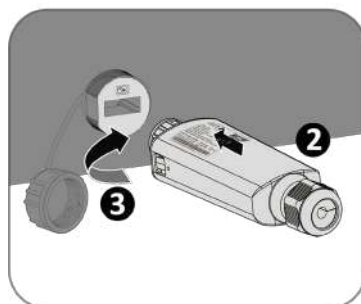
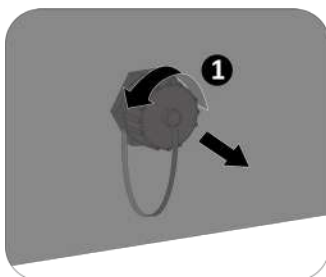



Fig. 29. Remove the cap

Fig. 30. Connect the Communication device

### 7.7.2 LAN cable connection (optional – no Ethernet port!)

 The device has been installed on the mount and remove the cap on the COM 1 connector.

1. Open the communication device by pressing in the two release tabs on the housing (see Fig. 31).
2. Open the cable gland and remove the seal. Insert cable gland on LAN cable and attach seal for cable.

3. Feed the LAN cable through the housing of the communication device and insert it into the plug in the LAN port on the circuit board. (see Fig. 32).
4. Close the housing using the two release tabs and fasten the cable gland [⚠ W\_16/ ⚡ 2 Nm] (see Fig. 33).
5. Insert the communication device into the corresponding connection and screw the unit tight with the nut.

**NOTE: Do not rotate the actual Communication device when attaching it to the device.**

6. Ensure that the Communication device is securely connected and the label on the module can be seen. (see Fig. 34).
- » The Communication device is connected via LAN-Kabel to the device.

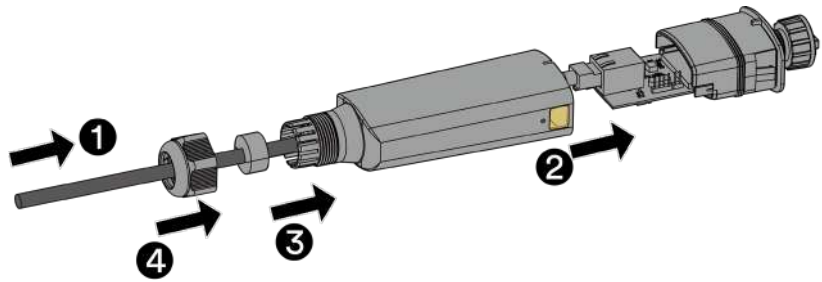
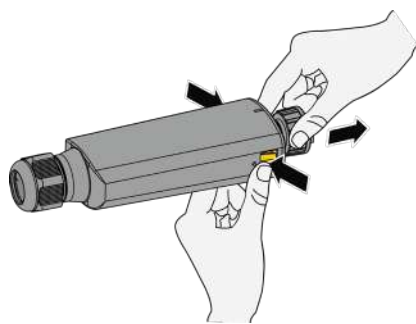

Fig. 31. Press in the release tabs on the communication device

Fig. 32. Feed the LAN cable through the housing and connect the LAN plug

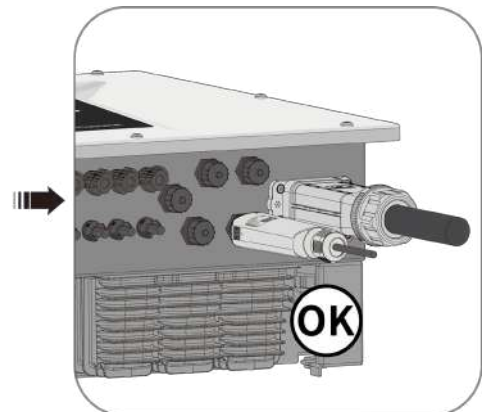
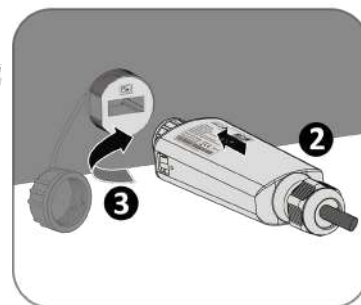
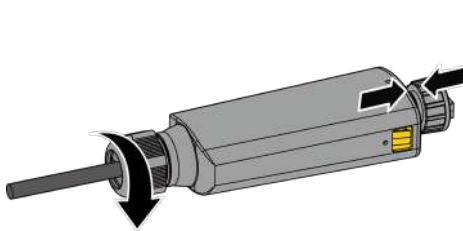

Fig. 33. Attach the seal and fasten the cable gland

Fig. 34. Connect the Communication device

### 7.7.3 RS485 cable connection

 CAUTION



**Damage to the inverter due to electrostatic discharge**

Components inside the inverter can be damaged beyond repair by electrostatic discharge.

› Earth yourself before touching the components.



**NOTE**

A straight through network cable of category 5E or higher is required for connection to the RJ45 socket. A network cable with good resistance to UV radiation is also required for use outdoors.

The RS485 connection can support communication with a maximum installation length (across all inverters) of 1000 m. The individual and control connected must be measured in accordance with EMC requirements EN 62920 if the length of the cable attached at the signal and control connection is more than 30 m according to the standard.

↻ The device has been installed on the mount.

1.Strip the insulation from the wire and crimp it into the corresponding terminal (see Fig. 35)

2.Unscrew the cover cap from the communication port (see COM2 or COM3) .

3.Press the cable support sleeve out of the threaded sleeve

4.Feed the network cable through the swivel nut and threaded sleeve. Attach the cable support sleeve to the network cable.

5.Pess the cable support sleeve into the threaded sleeve.

6.Insert the communication plug of cable into the device's communication port (see COM2 or COM3). Ensure that the cable is correctly locked in place. Turn the threaded sleeve onto the thread of the communication port (see COM2 or COM3) on the device.

7.Screw the swivel nut onto the threaded sleeve.  
(see Fig. 37)

» The RS485 cable is connected to the device.

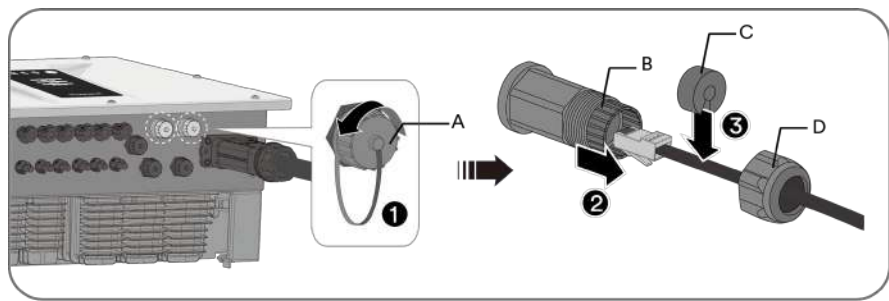
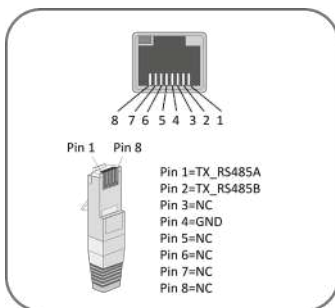

Fig. 35. Cable pin assignment

Fig. 36. Insert the network cable

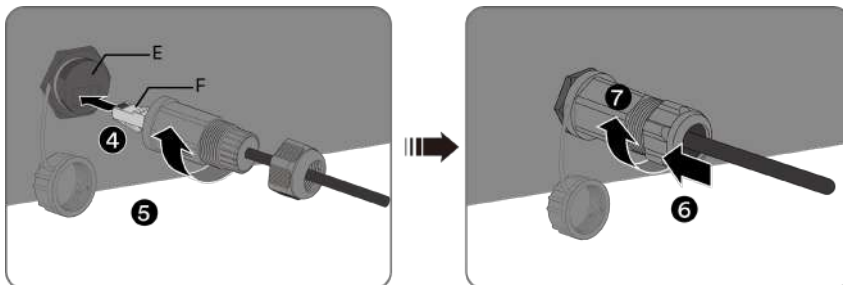

Fig. 37. Connect the network cable

Key

A	Cover cap	D	Swivel nut
B	Threaded sleeve	E	Communication port
C	Cable support sleeve	F	Communication plug

#### 7.7.4 RS485 cable connect to the Smart-Meter for dynamic feed

If you want to implement the function dynamically, you need to install the Smart-Meter. The communication device is only compatible with the **Eastron Smart-Meter (SDM630** – Article No. 3015600 is available via our customer service).





#### NOTE

The Smart-Meter must support the MODBUS protocol and communicates with baud rate 9600, parity "None", Stop-Bits "1"

Ensure that individual wires at the terminal contact of the Smart-Meter are attached with the correct torque and cannot work loose. Attach protective cover if fitted.

↻ The RS485 cable is connected to the device and the Smart-Meter have been firmly installed on a mounting bracket.

1. Strip the insulation of the other side from the network cable and screw copper wire to the corresponding terminal of the Smart-Meter. [  PH0  0.7Nm]. (See Fig. 38).

» The RS485 connection established with the smart meter. Lay signal cable correctly.

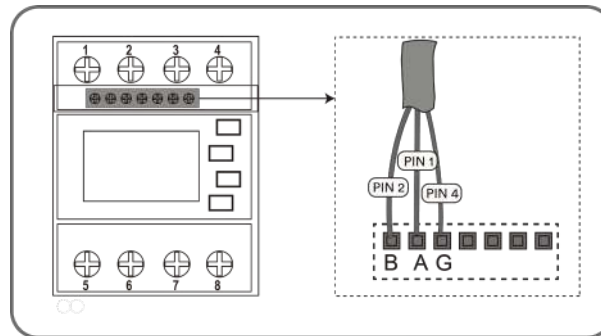

Fig. 38. RS485 cable connect to the Smart-Meter

### 7.7.5 RS485 bus system connection



#### NOTE

When using the RS485 bus system, you must assign a unique IP address to each bus device (inverter, sensor)  
 > 5 devices or > 100 m - Terminate the first and last device of the communication link (device/smart meter) through configured RS485 connector with integrated 120 Ohm terminating resistor.  
 Follow the connection diagrams in the associated application note "Dynamic feed-in limit and blueplanet web with/without data logger" in the download area on our website



#### NOTE

One inverter with Communication device can connect to up to four inverters without Communication device. The communication between the inverter and the Communication device can be done through RS485 bus.





#### NOTE

The inverter can connect to third party data monitoring unit. The data monitoring unit must support the MODBUS protocol.  
 Ensure that the Communication device is removed when the inverter connect to third party monitoring unit.

⌚ The RS485 cable is connected to the device and the Smart-Meter have been firmly installed on a mounting bracket.

⌚ Make sure the AC cable is totally isolated from AC power before connecting the SmartMeter and Data Logger

1.The rest of RS485 communication port (see COM2 or COM3) of the first inverter or the last inverter can connect a smart meter or a Data Logger.

2. Strip the insulation of the other side from the network cable and screw copper wire to the corresponding terminal. [  PH0  0.7Nm]. (See Fig. 39 Fig. 40).

» The RS485 bus system connection established. Lay signal cable correctly.

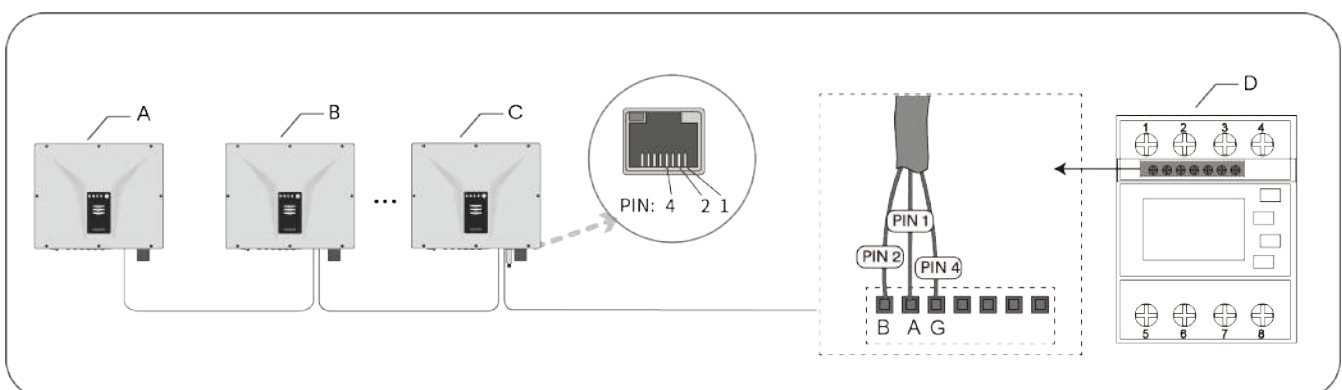

Fig. 39. RS485 Bus system connection with Communication device

Key			
A	Inverter with terminating resistor (if applicable)	C	Inverter with communication device
B	Inverter	D	Smart-Mete

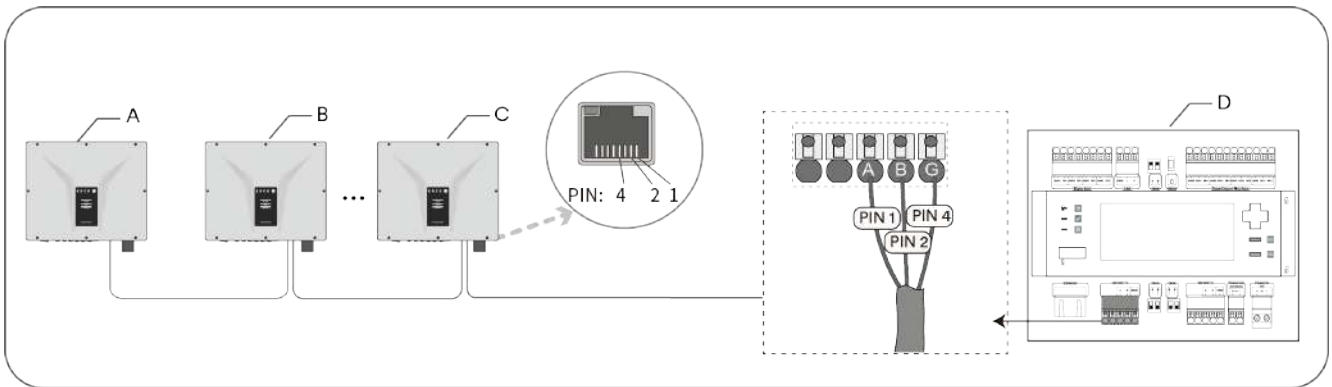

Fig. 40. RS485 Bus system connection with Data Logger

Key			
A	Inverter with terminating resistor (if applicable)	C	Inverter without communication device
B	Inverter	D	Data Logger

### 7.7.6 Inverter Off connection



#### NOTE

The digital input of the device is intended for connection of a Powador-protection device. When using devices from other manufacturers or in combination with KACO inverters, interface switches as a minimum must be used for shutting down devices from other manufacturers.



#### NOTE

If the Powador-protection device is connected, the interface protection parameters must be set according to the associated application note "Application note powador-protect" in the download area on our website.



#### NOTE

A straight through network cable of category 5E or higher is required for connection to the RJ45 socket. A network cable with good resistance to UV radiation is also required for use outdoors.



#### NOTE

If several inverters connect to one Powador-protection device, One of the RS485 communication port (COM4 or COM 5) of the first inverter connect to the Powador-protection device, the rest RS485 communication port connect to the next inverter. The other inverters connect one by one through the straight through network cable.

 The device and the Powador-protection device have been firmly installed on a mounting bracket.

- 1.Strip the insulation from the wire and crimp it into the corresponding terminal (see Fig. 41)
- 2.Unscrew the cover cap from the communication port (see COM4 or COM5) .
- 3.Press the cable support sleeve out of the threaded sleeve
- 4.Feed the network cable through the swivel nut and threaded sleeve. Attach the cable support sleeve to the network cable.
- 5.Pess the cable support sleeve into the threaded sleeve.
- 6.Insert the communication plug of cable into the device's communication port (see COM4 or COM5). Ensure that the cable is correctly locked in place. Turn the threaded sleeve onto the thread of the communication port (see COM4 or COM5) on the device.

7. Screw the swivel nut onto the threaded sleeve.  
(see Fig. 43)

8. Strip the insulation of the other side from the network cable and screw copper wire to the corresponding terminal of the Smart-Meter. Screwdriver type: SL1.5, tightening torque: 0.6 Nm (see Fig. 44).

» The RS485 connection established with the Powador-protection device.

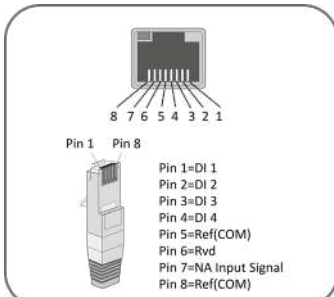

Fig. 41. Cable pin assignment

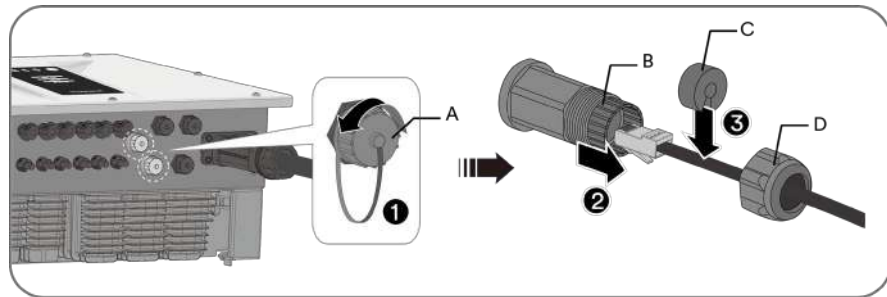

Fig. 42. Insert the network cable

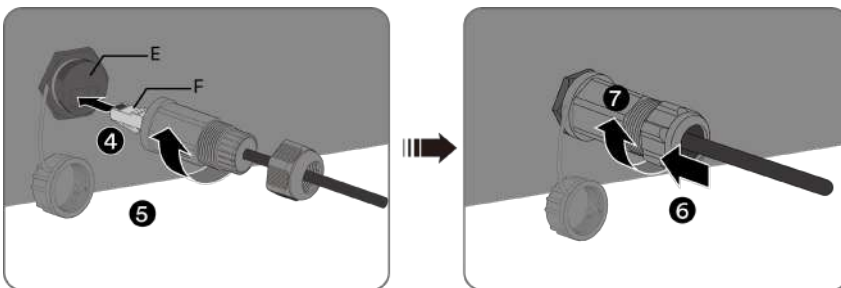

Fig. 43. Connect the network cable

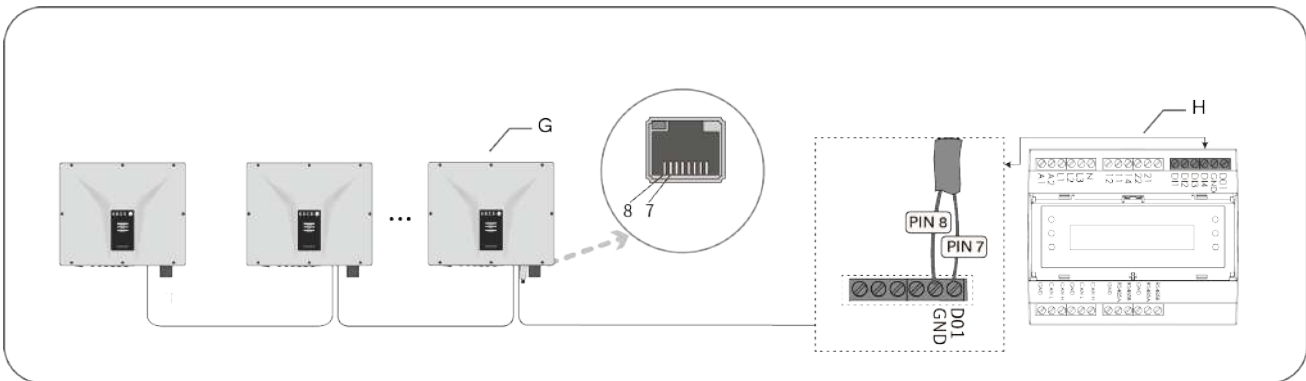

Fig. 44. Connect the network cable to Powador-protection device

#### Key

A	Cover cap	E	Communication port
B	Threaded sleeve	F	Communication plug
C	Cable support sleeve	G	Inverter with Communication device
D	Swivel nut	H	Powador-protection device

🔄 **Open the corresponding APP for these devices.**

1. Select <Select Inverter> in the < Communication device> menu and view the < Functions/Features > via the <Settings for> menu.

2.Enable the <NA-Protection> function (See Fig. 110 on page 50)

» NS Protection operation is enabled.

### 7.7.7 Ripple control receiver connection



#### NOTE

A straight through network cable of category 5E or higher is required for connection to the RJ45 socket. A network cable with good resistance to UV radiation is also required for use outdoors.



#### NOTE

If several inverters connect to one ripple control receiver, One of the RS485 communication port (COM4 or COM 5) of the first inverter connect to the ripple control receiver, the rest RS485 communication port connect to the next inverter. The other inverters connect one by one through the straight through network cable.

⌚ The device and the ripple control receiver have been firmly installed on a mounting bracket.

- 1.Strip the insulation from the wire and crimp it into the corresponding terminal (see Fig. 45)
  - 2.Unscrew the cover cap from the communication port (see COM4 or COM5).
  - 3.Press the cable support sleeve out of the threaded sleeve
  - 4.Feed the network cable through the swivel nut and threaded sleeve. Attach the cable support sleeve to the network cable.
  - 5.Pess the cable support sleeve into the threaded sleeve.
  - 6.Insert the communication plug of cable into the device's communication port (see COM4 or COM5). Ensure that the cable is correctly locked in place. Turn the threaded sleeve onto the thread of the communication port (see COM4 or COM5) on the device.
  - 7.Screw the swivel nut onto the threaded sleeve.(see Fig. 47)
  8. Strip the insulation of the other side from the network cable and screw copper wire to the corresponding terminal of the ripple control receiver. Screwdriver type: SL1.5, tightening torque: 0.6 Nm (see Fig. 48).
- » The RS485 connection established with the ripple control receiver.

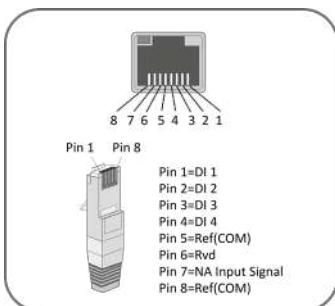

Fig. 45. Cable pin assignment

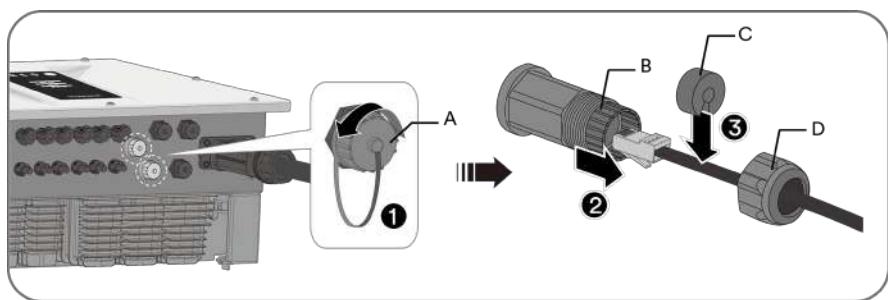

Fig. 46. Insert the network cable

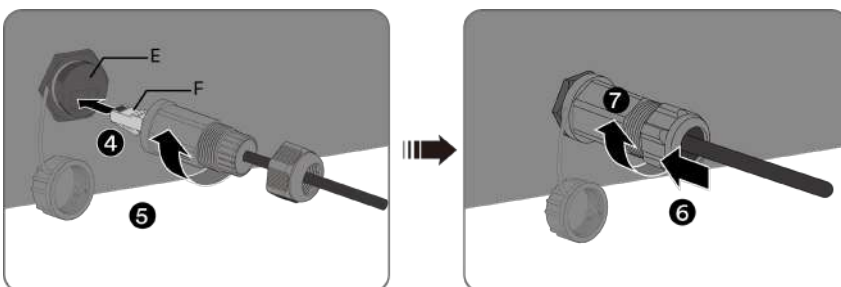

Fig. 47. Connect the network cable

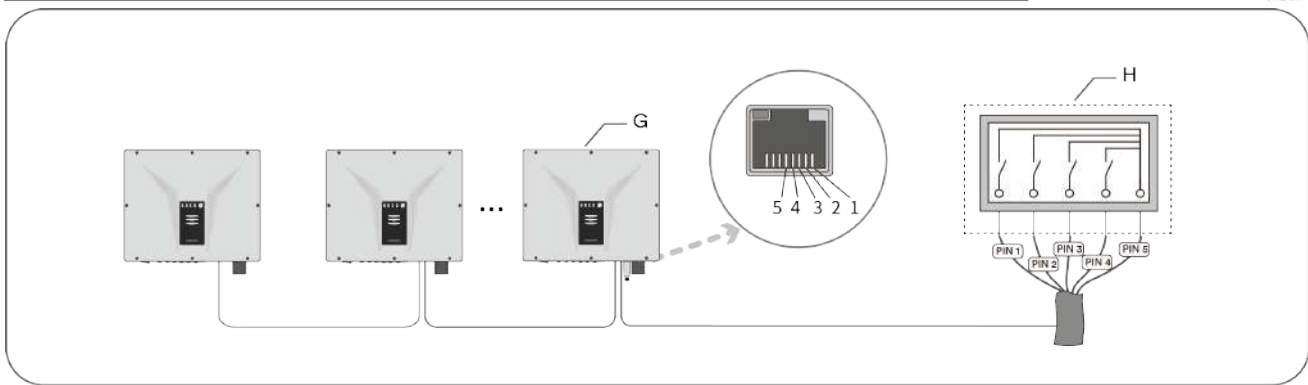

Fig. 48. Connect the network cable to ripple control receiver

Key

A	Cover cap	E	Communication port
B	Threaded sleeve	F	Communication plug
C	Cable support sleeve	G	Inverter with Communication device
D	Swivel nut	H	Ripple control receiver

**WARNING!** Incorrectly performed connections can cause damage to the hardware. External components must not deliver more than 5 mA per input channel.

↻ Ripple control receiver is professionally mounted&installed.

- 1 Comply with the cable requirements:  
Max. cable cross-section 1.5 mm<sup>2</sup>; insulation length 9 mm  
Max. cable length when 0.5 mm<sup>2</sup>: 100 m

2 Attach connection leads to the corresponding connection terminals (DI1 ... DI4,GND).

**Samples: (In case of all inputs are configured as ACTIVE LOW):**

- All inputs is open -> P<sub>Out</sub>=100%,  
UDI1=24V; UDI2=0.8V; UDI3=24V; UDI4=36V -> P<sub>Out</sub>= 60%,  
DI3 at GND; DI1, DI2, DI4 open -> P<sub>Out</sub>= 30%,  
All inputs on GND ->P<sub>Out</sub>= 0%

» The ripple control is correct connected

D1 (1)	D2 (2)	D3 (3)	D4 (4)	Output power (in % of the AC <sub>RPO</sub> )	Note:
0	0	0	0	100 %	A logical <b>1</b> means that the corresponding input must be switched to GND or an input voltage of 0-1V must be applied. A logical <b>0</b> means that the respective input remains open, unconnected, or is applied with a voltage in the range 4,5 - 40V
1	0	0	0	100 %	
0	1	0	0	60 %	
0	0	1	0	30 %	
0	0	0	1	0 %	
1	1	1	1	(configurable acc. to need)	

Fig. 49. Configure power level



**NOTE**

In Austria grid code, Pin8 can be defined as GND, and pin7 can be defined as Remote off. The inverter will turn off after the Pin 7 and Pin 8 is short, and the inverter will operate normally after the Pin 7 and Pin 8 is open.

## 8 Commissioning

### 8.1 Requirements

#### DANGER



**Lethal voltages are still present in the connections and cables of the device even after the device has been switched off and disconnected!**

Coming into contact with the lines and/or terminals/busbars in the device can cause serious injury or death.

- › The device is only permitted to be commissioned by a qualified professional.
- › Unauthorised persons must be kept away from the device.

↻ The device has been mounted and electrically installed.

↻ The PV generator supplies a voltage above the configured start voltage.

1 Connect the grid voltage using the external circuit breakers.

2 Connect the PV generator using the DC isolator switch (0 > 1)

» The device begins operation.



#### NOTE

For initial start-up of the device, the enclosed communication device must be plugged into the connection port.

A mobile terminal device with a WIFI interface is required for monitoring and setting parameters. No serial number dependent password is required here.

The following functions are only available via the associated app:

1. Initial start-up.
2. Setting parameters
3. Special parameters (e.g. P(f), P(U), Q(U))
4. Reset to Factory defaults.

### 8.2 Preconditions relating to standards

#### **Attachment of safety label in accordance with UTE C15-712-1**

The code of practice UTE C15-712-1 requires that, upon connection to the French low-voltage distribution network, a safety sticker showing a warning to isolate both power sources when working on the device must be attached to each device

- Attach the safety sticker provided to the outside of the device housing where it is clearly visible.



## 9 Configuration and operation

### 9.1 Start condition

- ⌚ The communication device is connected to the device and firmly screwed in place.
- ⌚ The device is connected on the AC and DC sides and supplied with sufficient DC voltage.

**Note:** Note the status of the LED during initialization, during operation and in the event of fault messages. This can provide you with accurate information about the current operating status of the device.

- 1 Check on the communication device that the blue LED lights up during the initialization process. If not, check the fastening again. Otherwise, replace the communication device.
- 2 Check on the device that the blue LED lights up in feed mode. If not, there is a fault in the device.

**Note:** In case of faults, refer to the error code in the chapter 10.5.

» Continue to set up the device monitor.

### 9.2 Initial start-up

Initial start-up of the inverter is carried out via a hotspot WLAN connection between the communication device connected to the inverter and a mobile terminal unit with installed “KACO NX Setup” APP.

#### Step 1: Establishing a connection with the communication device

There are two ways to connect with the hotspot created by this unit:

- Establish a simplified connection with the communication device by opening the APP and reading in the QR code on the communication device with Setup Mode. After scanning the QR code, you will be shown a WLAN network with the name **B....** . When selecting this WLAN network, it is not necessary to enter a password. Your mobile device will connect to the device automatically. Further information see chapter 9.6.1 on Page 37.
- Connect by opening the WLAN settings on the mobile terminal device and selecting the WLAN connection with the designation **B....** and entering the password (registration code).
 

**Note:** The name SSID (serial number of the Connect-NX B...) and password (registration code) of the communication device can be found printed on the communication device.
- You are successfully connected to the communication device.

#### Step 2: Configuring the communication device and inverter

We recommend the following steps for the initial start-up:

- **Configuration communication device**
  - Set up time zone. See Chapter 9.7.1 on Page 40.
  - Configure network parameters. See Chapter 9.7.5 on Page 42 (Communication device Properties)
  - Setting the monitoring and control functions. See Chapter 9.7.4 on page 43.(Monitoring & Control)
- **Configuration Inverter**
  - Select country and grid standard. See Chapter 9.9.3 on page 49.
  - Set local grid requirement (observe local grid requirements! E.g. cos-phi, P(f), Q(U)....) See Chapter 9.9 on Page 47.
  - View the instantaneous values of the inverter in order to detect any faults. See chapter 9.9.1 on page 47.



#### NOTE

For further settings such as power control, zero-feed in or communication with a data logger, please refer to chapter 9.9.

### 9.3 Authorisation



#### NOTE

In order to use the full range of functions of the “KACO Device Manager” app, you should accept all requested authorisations. The app does not use these authorisations to record the user’s telephone data. The current description reflects the firmware version **2.0.5**. With newer firmware versions the following subchapters will be updated in time to inform you about current functions.



**NOTE**

Our KACO website offers a wide range of further product information to assist you during start-up. You can find this information in the download area under: <https://kaco-newenergy.com/de/downloads/>.

Follow the **QR code link** on the cover sheet to view the installation and start-up video.



**NOTE**

**No password** is required for **initial start-up**. A password must be entered again if it becomes necessary to change the parameters of the device after initial start-up.

The specific password for the inverter can be requested from KACO Service. <https://kaco-newenergy.com/de/service/kundendienst/>



**NOTE**

**TCP port 443**

Used for encrypted communication (HTTPS) between the device and the mobile app. This is a fundamental device function. The service is automatically enabled when the device is powered on and disabled when powered off, and no separate interface is provided for manually enabling or disabling it.

**TCP port 502**

Used for encrypted Modbus TCP communication. This port is enabled only when Modbus TCP mode is selected in the app and the device successfully connects to the network (obtains an IP address); otherwise, it remains closed.



**NOTE**

**Frequency band**

Before configuring the network, make sure that the WLAN router supports the 2.4G frequency band. The communication device can only be operated in the 2.4G frequency band.

**Installation location**

For a stable connection, the communication device or inverter should be no more than 10 m away from the router.

**Availability of SSID and password of the router**

The communication device supports only 32 characters for the SSID or password.



**NOTE**

We recommend integrating the communication device into your/your customer's WLAN network, if the signal quality of the network is insufficient or non-existent, then you will need to continue with hot-spot connection.

To use monitoring and control functions (Monitoring Portal "blueplanet web"), there must be a connection to the internet via the customer's WLAN network.

## 9.4 Operating system and system configuration

The corresponding, free APP **KACO Device Manger** from the relevant APP store can be installed on a mobile terminal unit (smartphone or tablet PC) with an **Android operating system, version 9.0 or newer** or **IOS operating system version 11.0 or newer**. You will find QR code links on the cover sheet.

Below you will find illustrations of the connection options for initial start-up of the device and its optional integration into a local network.

If you integrate the device into a local network, it is possible to connect the device to a web portal or a client (data logger, system controller).

**Option 1: Set-up via hotspot (with APP connection to the inverter with communication device)**

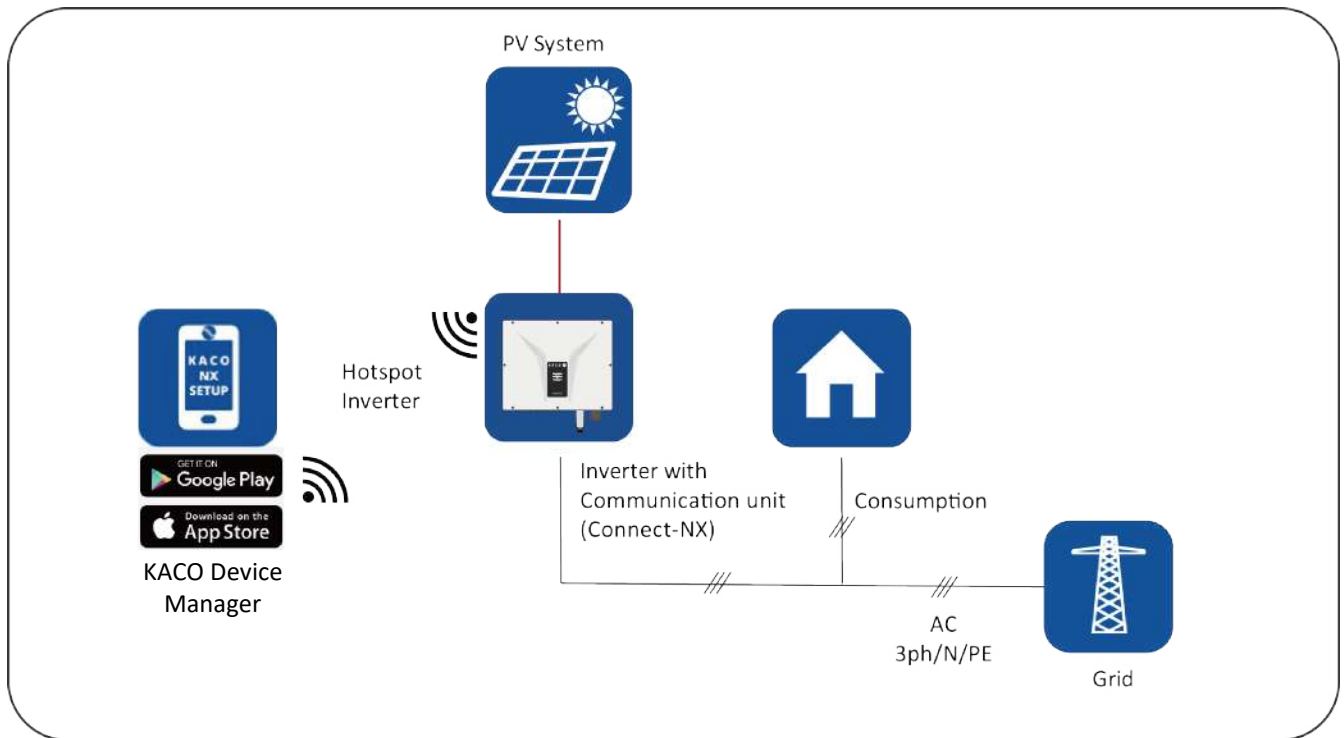

Fig. 50. Set up communication device via mobile end device – hotspot

**Option 2: Set-up via local network**

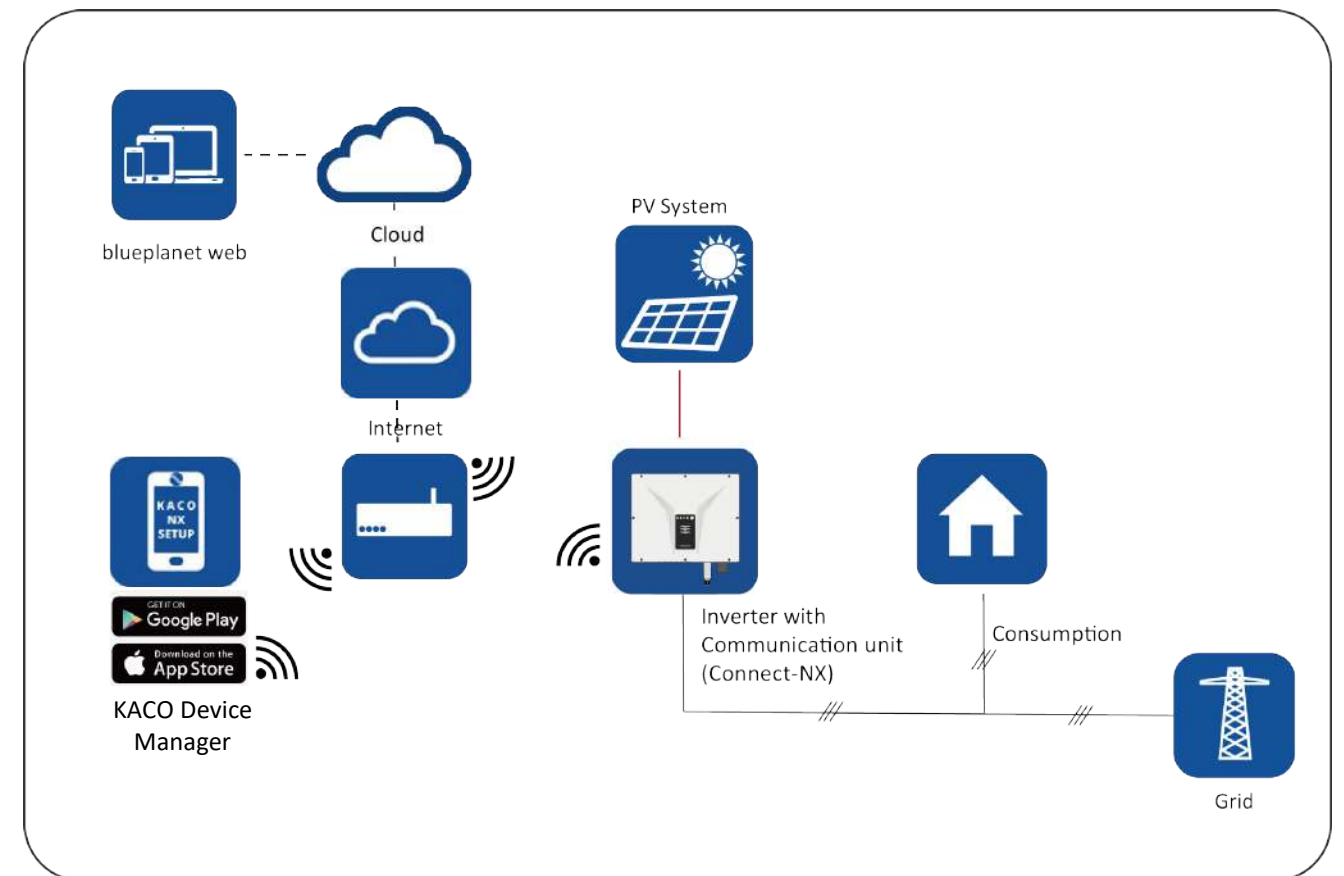

Fig. 51. Set up Communication device (Connect-NX) via local network – WiFi 2.4G



**NOTE**

Please note the additional documents for the communication structure with and without data logger. These can be found in the download area on our homepage in the device order under application note.

## 9.5 Signal elements

There are status LEDs on the communication device and on the inverter housing that indicate the operating status. The LEDs can display the following states:

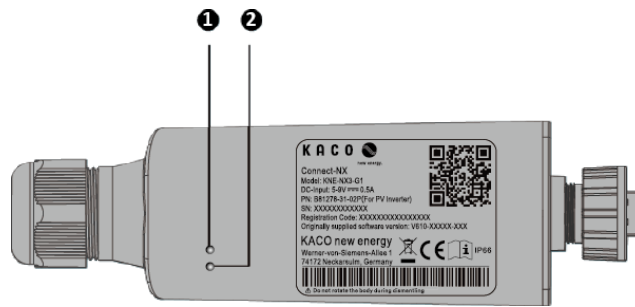







Fig. 52. LEDs on communication device

Item	Operating status on communication device	LED	Description
1	Network communication		The blue LED lights up while searching for the IP address and when a connection to the web portal or client is established (data logger, EMS, etc.).
			Blue LED flashes when there is a connection with a local network (router). <ul style="list-style-type: none"> <li>The Communication device has been configured in the WLAN network and is currently establishing a connection to the router.</li> <li>The Communication device is connected to a local network (router) but does not yet have an active connection to the web portal or client (data logger, EMS, etc.).</li> </ul> <p><b>Note:</b> For AP network configuration, you must be connected to the device's local WLAN network to re-enter the router information. The password for the local WLAN network is the registration key found on the name plate</p>
			Blue LED is off: The communication device is in AP mode. The communication device forms a hot spot for a direct communication connection. Reasons for this could be. <p>Modbus TCP mode, no client connect to stick</p> <ul style="list-style-type: none"> <li>The communication device has not yet been integrated into a local network.</li> <li>The communication device was integrated into a local network but could not connect to the local router within 100 seconds (e.g. bad communication device connection or incorrect access data).</li> </ul> <p><b>Note:</b> After the 100 seconds have elapsed, the communication device switches to AP mode for 15 minutes and forms a hot spot for direct communication connection. In AP mode, it is possible to carry out the network configuration again.</p>
2	Device communication		The green LED lights up. The LED indicates the communication status between the communication device and the inverters connected to the RS485 bus. <ul style="list-style-type: none"> <li>The communication device has an active connection to all inverters that are stored in the communication device</li> </ul>
			The green LED flashes. This has the following cause: <ul style="list-style-type: none"> <li>Reset, restart or firmware update of communication device in process.</li> <li>Not all inverters stored in the communication device are accessible.</li> </ul>
			The green LED is off. The communication device has no connection to all inverters known to it that are connected to the RS485 bus. <p>This has the following cause:</p> <ul style="list-style-type: none"> <li>Communication device has no voltage supply (DC voltage at the inverter too low or DC switch OFF).</li> </ul>

		RS485 bus connection to all known inverters interrupted. <ul style="list-style-type: none"> <li>• Communication device not mounted correctly or defective, or RS485 interface of the inverter defective.</li> </ul>
--	--	---



Fig. 53. LEDs on device

Operating status on Device			Description
SOLAR	GRID	STATUS	
			All the blue "SOLAR", "GRID" and "STATUS" LEDs light up. This status indicates that the inverter is working normally.
			The blue "SOLAR" and "GRID" LEDs light up. The blue "STATUS" LED flashes with 1s interval. This status indicates that the inverter operates with the power derating due to high temperature.
			The blue "SOLAR" LED lights up. The blue "GRID" and "STATUS" LEDs flash with 1s interval. This status indicates that the inverter operates with external power control.
			The blue "SOLAR" and "GRID" LEDs flash with 1s interval. This status indicates that the inverter is performing self-test during start operation or reconnection.
			All the blue LED flash with 1s interval. This status indicates that the inverter operates with firmware updating. .
			The blue "SOLAR" LED flashes with 0.5s interval. The red "STATUS" LED lights up. This status indicates that there is a warning information on PV side or insulation fault.
			The blue "GRID" LED flashes with 1s interval. The red "STATUS" LED lights up. This status indicates that there is a warning information on grid side.
			The red "GRID" and "STATUS" LEDs light up. This status indicates that there is a fault on the grid side.
			The red "STATUS" LED flashes with 0.5s interval. This status indicates that there is a critical error information in the inverter such as inverter damaged or DSP reset.
			The red "STATUS" LED lights up. This status indicates that other warnings and faults have occurred in the system.

## 9.6 Connecting to the device

### 9.6.1 Connecting to the device for the first time

↻ WLAN of your mobile device is enabled, and any existing customer WLAN network router is switched on.

**Note:** The initial connection is generally made via a hotspot.

↻ The “KACO Device Manager” APP from the Android/iOS Store has been installed and opened on your mobile end device.

↻ The communication device is connected to the COM1 port of the device. (see Chapter 7.7 on page 23)

**Note:** Each device in the device series must be configured with the enclosed communication device. Thereafter there is a fixed assignment to the device.

↻ The access details for your / your customer’s WLAN network are to be made available to the solar installer.

1. Select <Commissioning>.

2. Grant authorisation for use of images, videos and camera.

3. Scan the QR code on the communication device. Max. distance from the scan frame shown in the scan window. (See Fig. 55)

» The connection to the hotspot WLAN is established (B...).

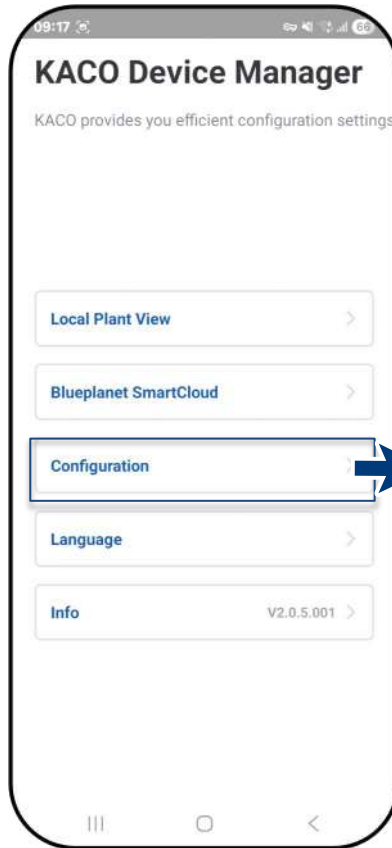

Fig. 54. Select <Commissioning>



Fig. 55. Scan QR code on communication device

**Note:** The connection is established exclusively via the hotspot until **step 6**. This is how long your mobile end device must be kept near the communication device.

4. Confirm the WLAN network of the communication device by tapping the **B...** number displayed.

**Note:** After a short time you will have 2 options in <Network Configuration>.  
**Option 1-** Connect the communication device to the local WLAN network.  
**Option 2 –**Use the existing hotspot: **Now follow the instructions in Chapter 9.6.2 on page 39**

5. Select the customer’s WLAN network. The customer needs to enter the password and press the <Confirm> button.

**Note:** If the connection fails, the communication device is not in range of the customer’s router. You can improve the signal quality between the communication device and the router by interposing a **repeater**. However, this must also be connected to the same network.

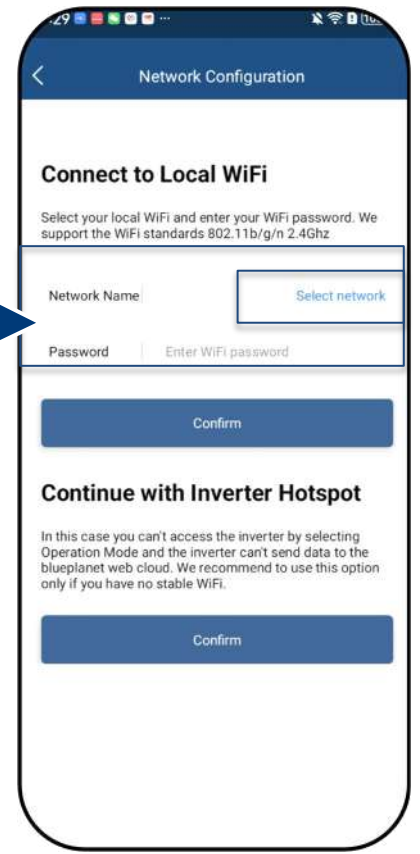
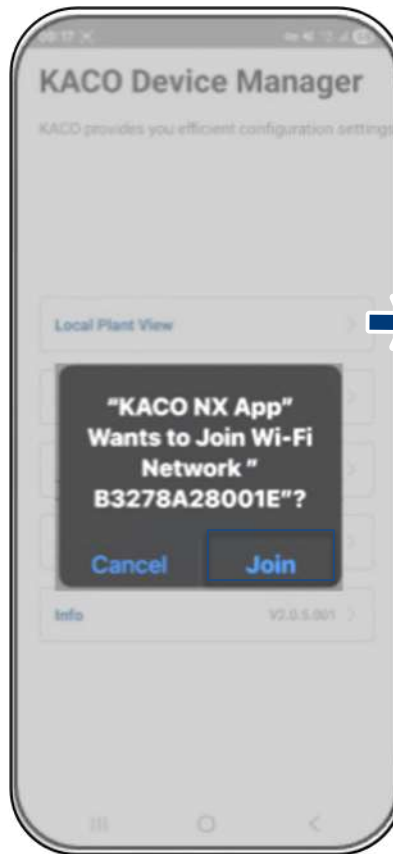

Fig. 56. Access to the communication device with a mobile end device

Fig. 57. Enter the access data for the customer’s WLAN network

**Note:** If the connection is successful, your communication device will be connected to the customer’s WLAN network. Your mobile end device now also needs to be connected to the customer’s WLAN network.

6. In <Settings> on the mobile end device, you now need to establish a connection with the customer’s WLAN network.

**Note:** The password is pre-filled if a connection already exists.

7. Note the checklist and status. Process takes up to 5 minutes.

» Your communication device and your mobile end device are now on the same customer WLAN network. A successful connection is displayed in a new window.

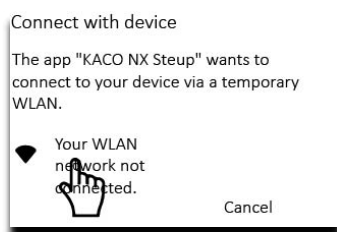

Fig. 58. Connect the inverter to the customer’s WLAN

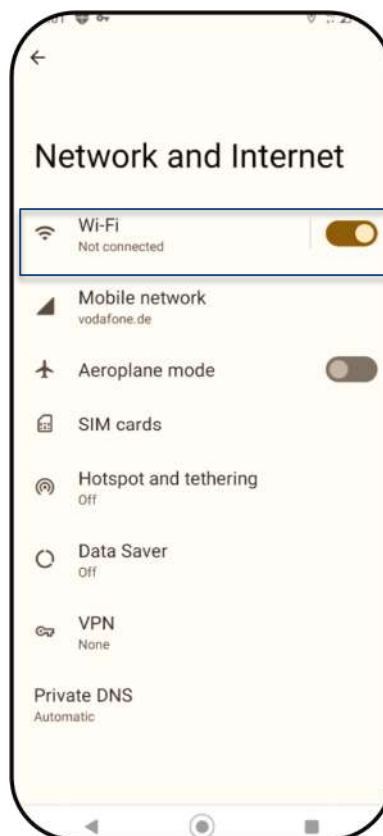

Fig. 59. Connect the mobile end device to the customer’s WLAN

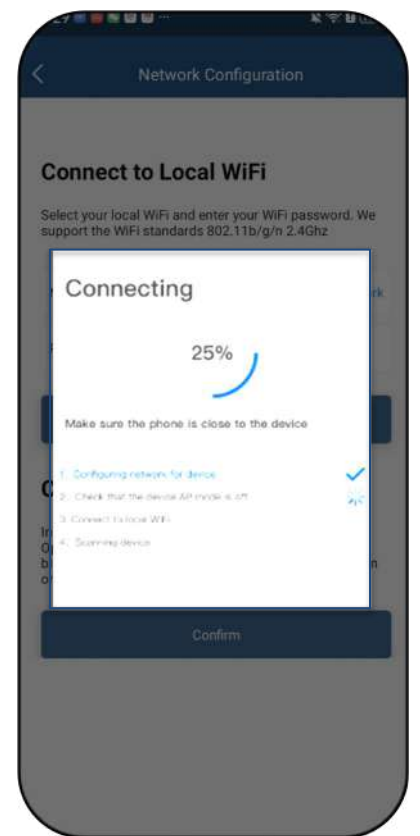

Fig. 60. The connection to the customer’s WLAN network is established



## 9.7 Menu of the communication device

**Note:** In both cases you now have access to the communication device. This is where you can make settings that do not directly affect the function of the inverter.

**Note:** Observe the step-by-step procedure for initial commissioning in chapter 9.2 on Page 32

**Note:** After completing or exiting initial start-up, the serial-number-based password is required to set further parameters. See Chapter 9.9.2 on page 48.



Fig. 65. Menu of the communication device

### 9.7.1 Setting the time zone

**Note:** The time communicated by the network is GMT. You should now adjust the time zone depending on the installation location.

This time is also used for the display on the “blueplanet web” portal.

↻ <Communication Device> menu opened.

1. Select < Time Zone >. For Germany, this would be: Amsterdam, Berlin...

2. Confirm the selection with <Confirm>.

**Note:** If the internet is not available on the network, you will have to make the changeover to summer/winter time manually.

» Time zone set.



Fig. 66. Menu of the communication device



Fig. 67. Set time zone

### 9.7.2 Reset to factory defaults

🔄 <Communication device > menu opened.

**Note:** Pressing <Reset Communication Device> resets **all** created configurations to the factory defaults.

These consists of:

- Network configurations
- Feedin and Smart-Meter Settings
- Function Monitoring & Control
- Time Zone
- Internal inverter list from the communication device is deleted from the memory.

**Note:** Inverter settings are not reset by the communication device during a restart

1. Press the <Confirm> button in the warning message to trigger a reset.

» Check the connection after restart.



Fig. 68. Reset the communication device.

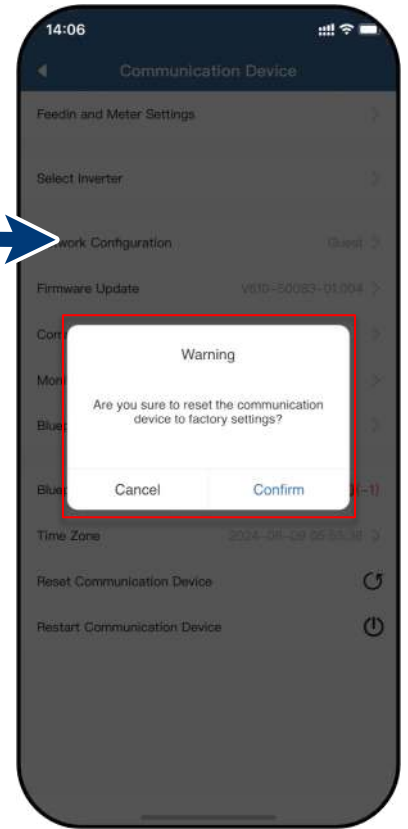

Fig. 69. Observe the note on resetting the communication device!

### 9.7.3 Resetting a faulty connection

🔄 <Communication device > menu opened.

**Note:** The communication device is restarted via the <Restart communication device > icon. Set values on the unit are not reset.

1. Press the <Confirm> button in the warning message to trigger a restart.

2. Reset the communication device with <Reset Communication Device>.

» Check the connection after restart.

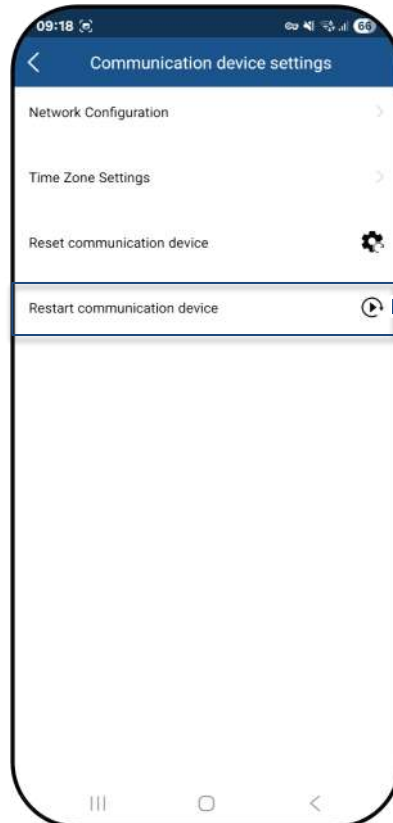

Fig. 70. Restart the communication device.

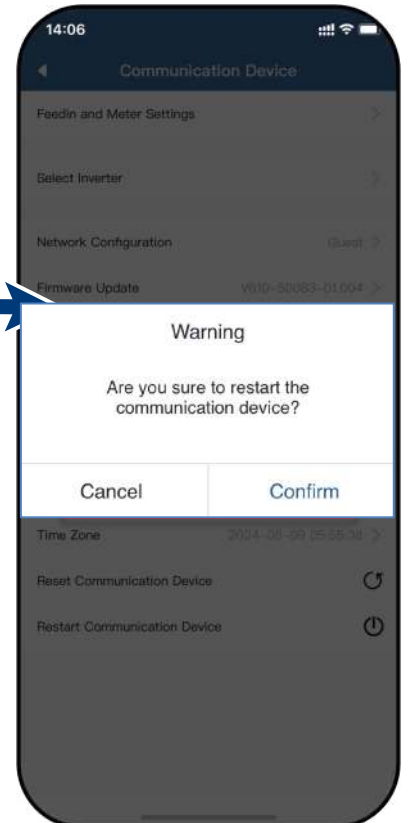

Fig. 71. All configurations remain unchanged.

## 9.7.4 Changing the customer WLAN network

🔄 <Communication device> is open

**Note:** This allows you to change the WLAN configuration when you replace the device, router or your mobile device.

1. Open <Network Configuration>.
2. Select the network in the <Network name> field using the drop-down menu.
3. Enter the password for the network and save the change with <Confirm>.

**Note:** If the router is defective or no longer reachable and the communication device cannot establish a connection and the blue LED lamp on the communication device does not light up, you can find the SSID of the communication device hotspot with the serial number of the communication device in your WLAN list. You can establish a connection with the hotspot of the communication device by entering the registration code on the label as a password.

**Note:** Data is transferred after approx. 30-60 minutes.



Fig. 72. Network properties

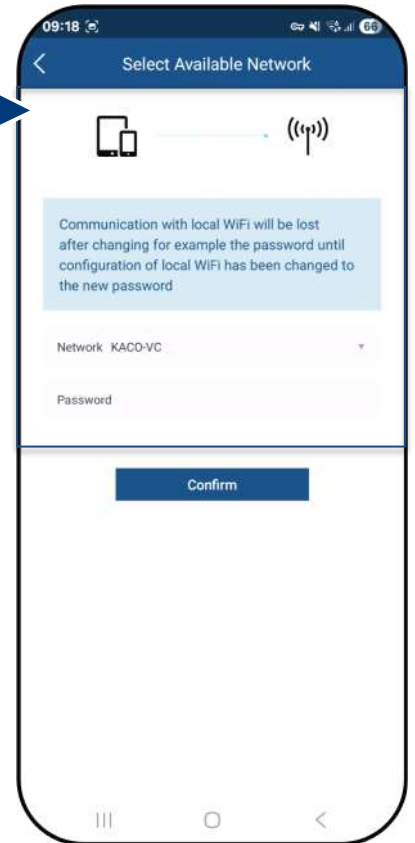

Fig. 73. Change network

## 9.7.5 Configure network parameter

**Note:** Here you can assign a static IP address to the inverter so that your router always uses the same address.

🔄 Connection to the unit established

1. Select <Communication Device Properties >.
  2. <DHCP> for automatic IP address assignment or for more security.
  3. <DHCP> deactivate <DHCP> and enter IP address for your <Communication device >.
  4. Optionally: Activate <DNS> and enter primary DNS address.
  5. Save settings with <Confirm.>.
- » IP settings successfully carried out.



Fig. 74. Set unit parameters

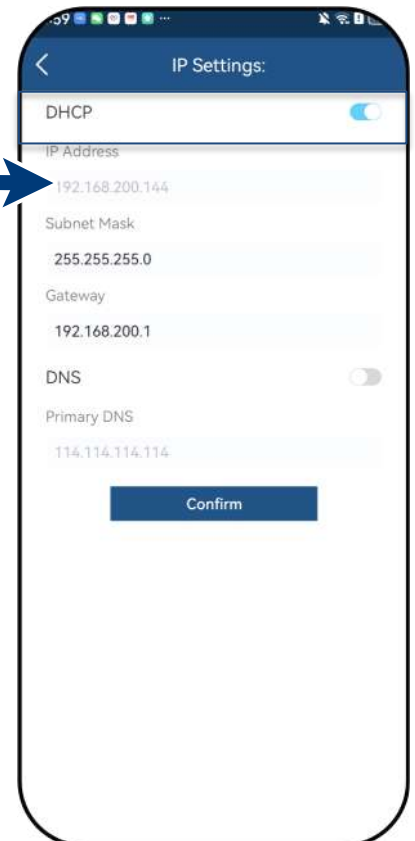

Fig. 75. View all parameters

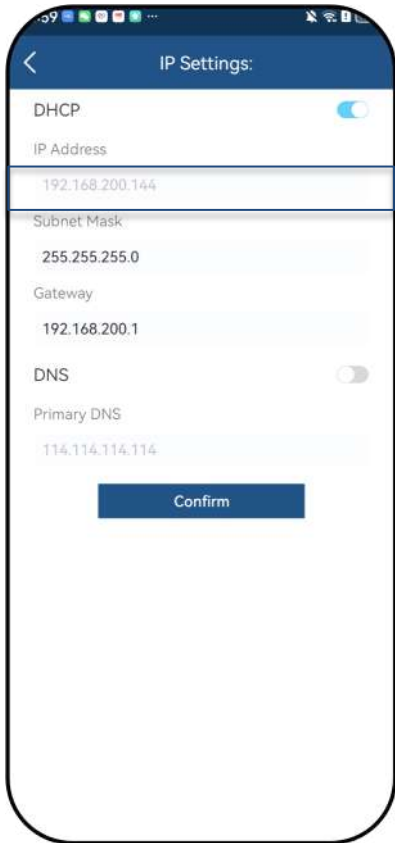

Fig. 76. Setting the IP address

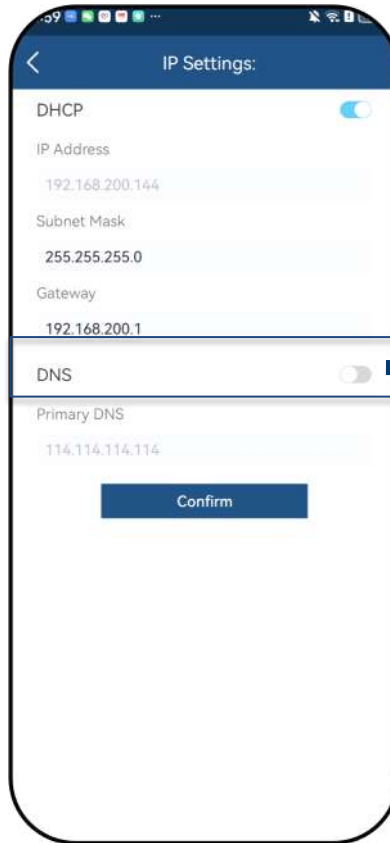

Fig. 77. Activate DNS

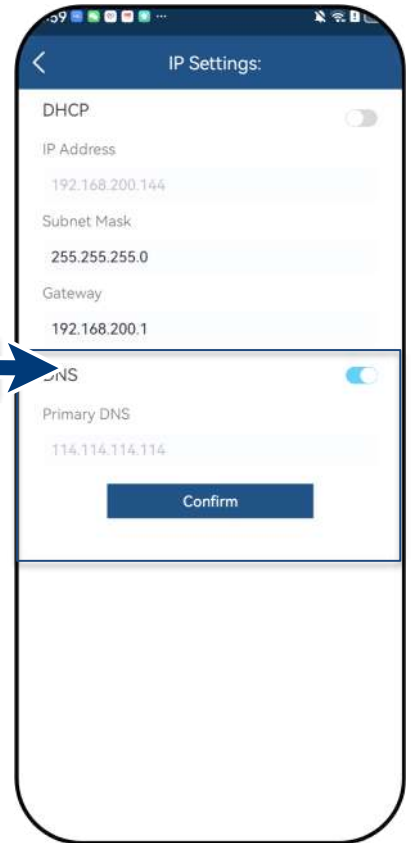

Fig. 78. Set DNS address

### 9.7.6 Cloud service

**Note:** If a data logger is to be integrated, the <Operating mode> <KACO blueplanet web> must be activated.

↻ < communication device> is open.

1. Open <Monitoring & Control>.
2. Check the status of >Cloud Service> using the signal indicator.

**Note:** If the signal indicator is red, the communication line to the data logger must be checked.

» Values can be checked on the data logger.

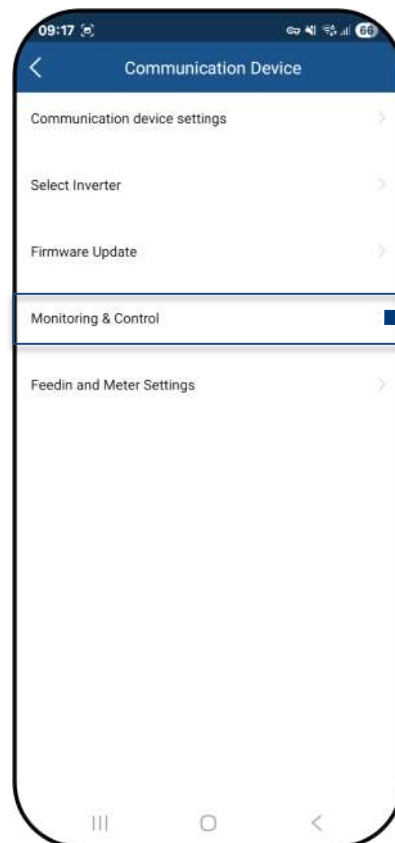

Fig. 79. Set data transmission interval (web portal)

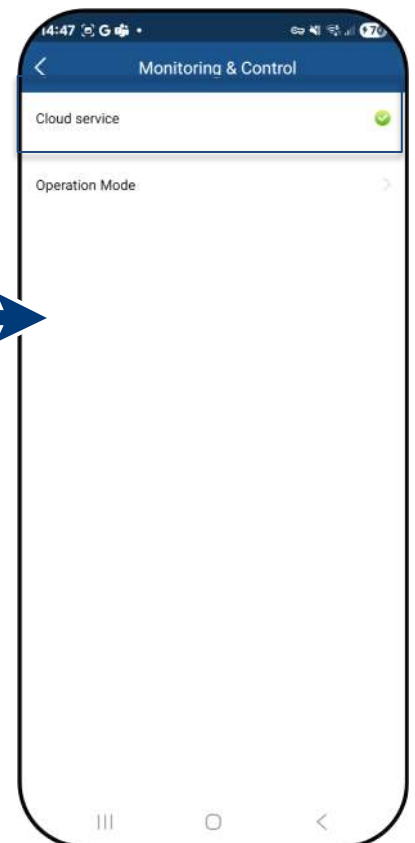

Fig. 80. Confirm interval

### 9.7.7 Monitoring and control

↻ The <Communication device > is registered on the customer's WLAN network and the router is connected to the internet.

**Note:** The device supports Modbus/TCP and Modbus/RTU with all standard SunSpec models. If there are concerns over security, write access can be deactivated via the SunSpec Register. The signal is transmitted via an installed RS485 line

1. Select < Monitoring & Control>> mode:
  - <**KACO blueplanet web**>: data from connected devices is uploaded to the KACO cloud server for evaluation.
  - <**Modbus TCP IP Server**>: By default, the communication device receives the Modbus TCP or SunSpec commands and a connected data logger responds to them.
  - <**Modbus TLS Server**>: As an alternative to TCP/IP, TLS provides significantly higher security for communication when exchanging commands between devices
  - <**APP (local)**>: local operation mode without further communication. (Standard)

2. Confirm the selection with <Confirm>.

» Operation mode set.

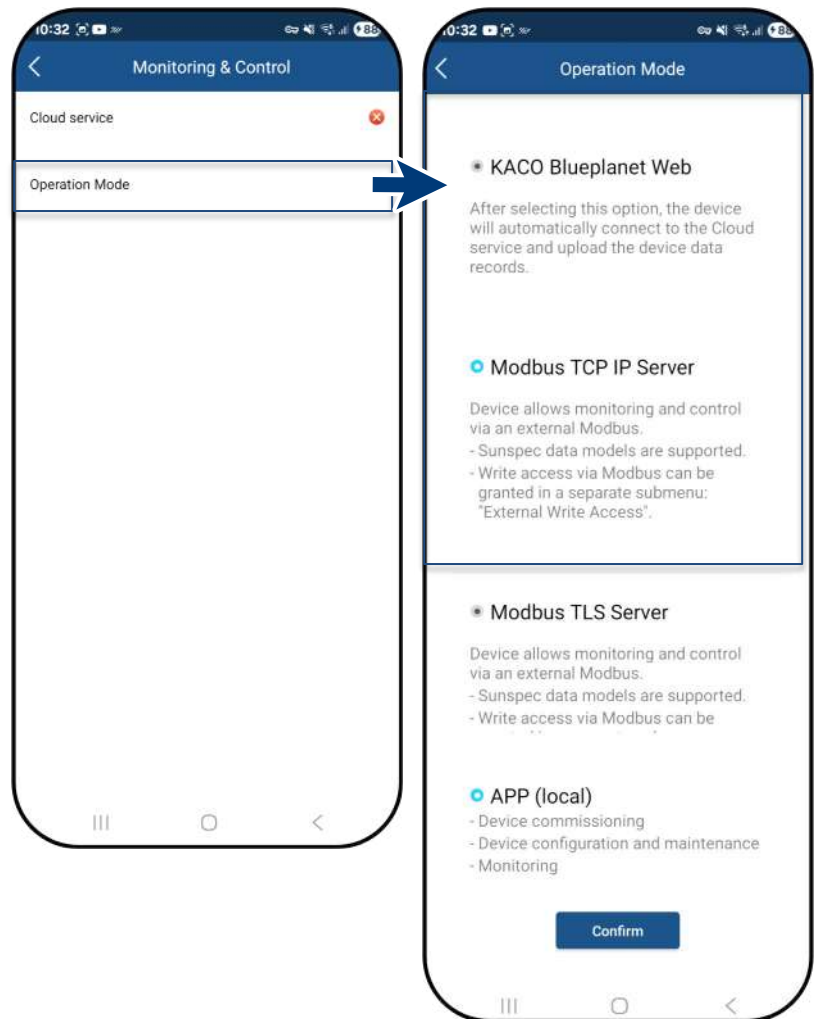

Fig. 81. Select monitoring & control Fig. 82. Select mode

### 9.7.8 Dynamic feed-in

<Communication device > menu opened.

The connection shown in the block diagram Fig. 85 has been established.

**Note:** For more information, see Chapter 9.15 on page 70.

1. Open the <Feedin and Meter Settings> menu.
2. Select << Meter model >> SDM630CT.  
- Only this Type with current sensors is compatible with this device
3. Switch on <Enable Meter Data Processing> when the meter is connected.
4. Switch on <Enable Feedin Control> when the meter is connected.
5. At <Maximum Feedin Power>, set the maximum power which the device may feed into the grid.

**Note:** This setting is only possible under 2 conditions:

1. Meter model connected to the device.
2. <Active Power Control> is enabled in the <Settings for> menu under <Activate / Deactivate Functions>.

6. Start the function with <Confirm>.

7. Please remedy if these conditions are not met. See Chapter 9.9.2 on page 49

» Dynamic feed-in is selected.

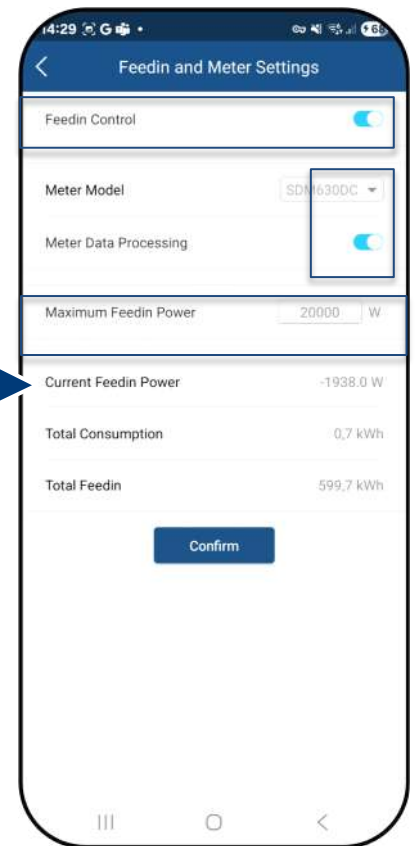
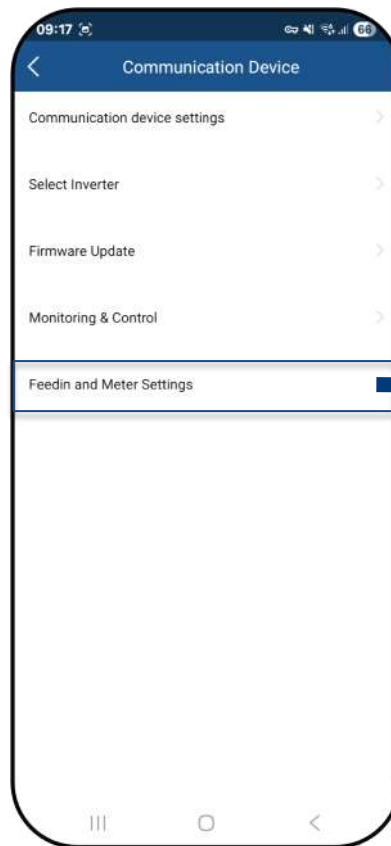

Fig. 83. Select feed-in and meter settings

Fig. 84. Select smart meter model and set max. feed-in power

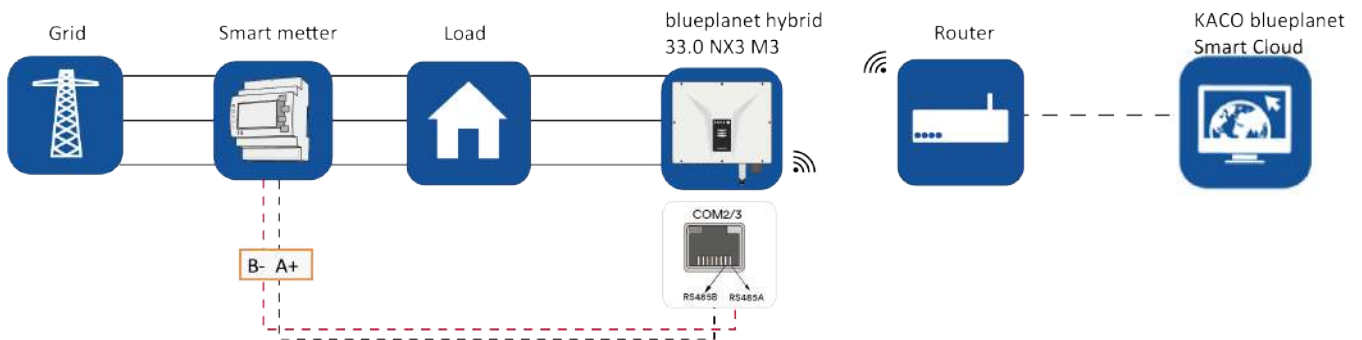

Fig. 85. Block diagram for dynamic feed-in when select SDM630CT

### 9.7.9 Viewing available inverters

🔄 All inverters are connected via a communication device.

1. Press the <inverter search> button.  
**Note:** Up to 5 inverters can be connected to one communication device. When the button is pressed, the communication device scans the connected inverters and automatically assigns the RS485 address and saves it in the communication device.
2. The desired inverter can now be selected for further parameter settings under <Available Inverters>.

3. Adjust the parameters in <Parameter Setup>.  
>> see Chapter 9.9.2 on page 48 or:  
View feed-in values of the selected device in <Instantaneous Values> >> see Chapter 9.9.1

» Device configured with country setting.

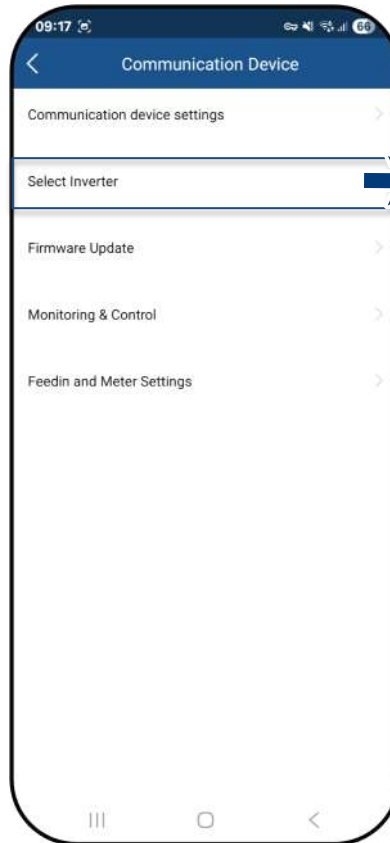

Fig. 86. Select inverter

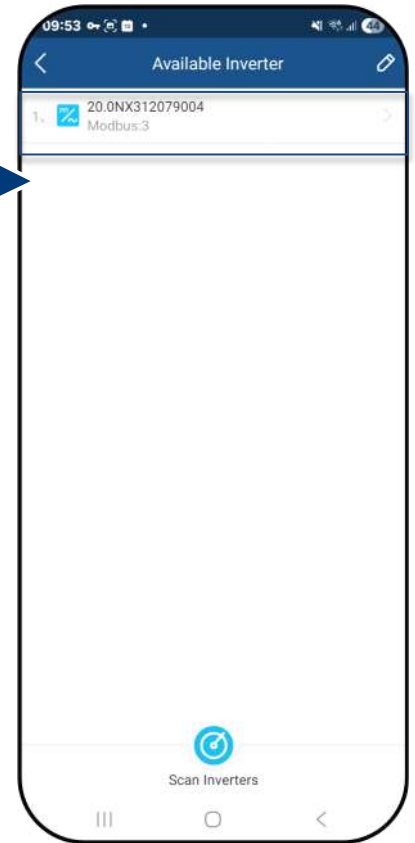



Fig. 87. Select the required inverter

### 9.7.10 Adjusting the Modbus address

🔄 Under <Available inverters>, the pin  must be pressed before selecting the inverter. A separate menu appears, which you can use to assign individual Modbus addresses to the individual inverters

**Note:** By default, the Modbus address "3" is stored here and should not be changed for an inverter. This value is used for communication with the data logger and Smart-Meter.

1. If necessary, enter a new value for each additional inverter that follows the first communication device and press the <Confirm> button after entering.

**Note:** With "Select ALL", all inverters in the communication chain are displayed.

» Modbus address configured.



Fig. 88. Opening the Modbus address menu via "Pen"

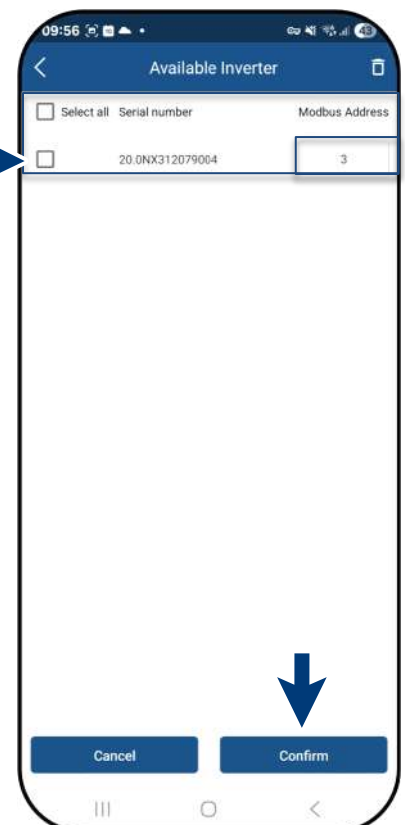

Fig. 89. Setting the mode address

## 9.8 Menu of Inverter

### 9.8.1 Viewing the instantaneous values

🔄 The required device is selected in <Available inverters> and the <Inverter Details & Settings> menu is opened.

1. Select <Instantaneous Values> and view information about the installation.

**Note:** All measured values for your PV system and the grid power are displayed. In addition, after solar feed-in, the daily values and yields are displayed.

**Note:** The measured values are only displayed for the selected device. A simultaneous evaluation of all inverters can only be carried out via our “blueplanet web” monitoring portal.

2. View current Power and Power Factor.  
3. View pending errors via <Error Code>. N/A = no error

**Note:** In the event of a pending error, note the **Error code list** in chapter 10.5 on page 76.



Fig. 90. Viewing the live values



Fig. 91. Overview of power values

### 9.8.2 Enabling external write access

🔄 You have the option of granting write access for external protocols. Access relates exclusively to the “Monitoring & control” menu. See Chapter 9.7.2

**Note:** By default, the function is disabled. After activation, take note of the information field in the window that appears.

1. If required, grant write access by pressing <Confirm>.

» External write access granted via SunSpec / KACO legacy protocol.

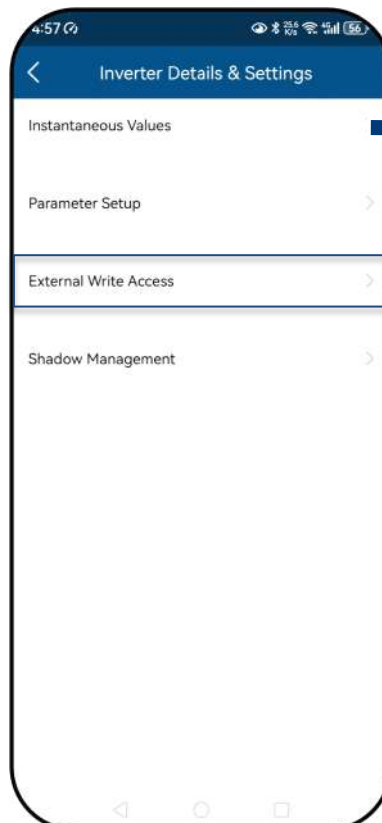
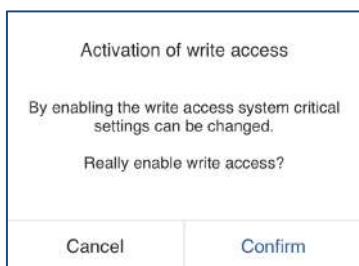

Fig. 93. Select external write access

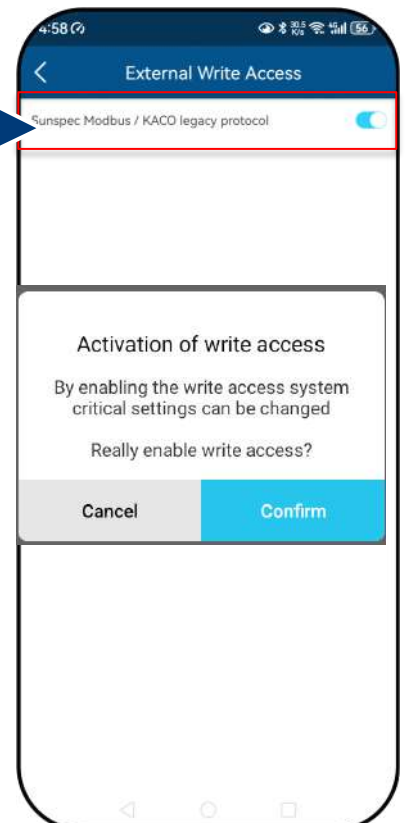

Fig. 94. Confirm activation of external write access

### 9.8.3 Shadow Management

The desired device is selected under <Available Inverters> and the <Inverter Details & Settings> menu is opened.

**Note:** Enables optimized MPP tracking for PV module shadow management. After the function is activated, each PV channel is scanned at a 10-minute interval. Captures and tracks the maximum power point voltage when the output power is not limited, and the input power of this channel is not overdriven.

1. Select < Shadow Management>.

2. In case of partial shading of a PV module, activate <Shadow Management> to generate additional MPP tracking points.

» Shadow management configured.

**Note:** Depending on the overall design of the PV system and the use of additional module optimizers, activated shade management may adversely affect tracking. **This is not a malfunction.**

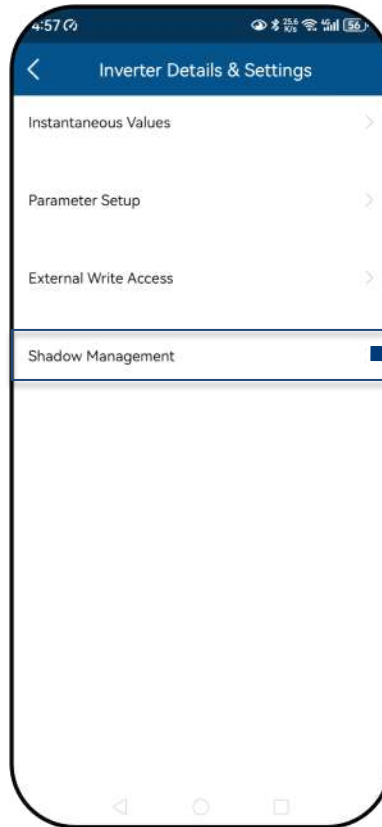

Fig. 95. Select shadow management

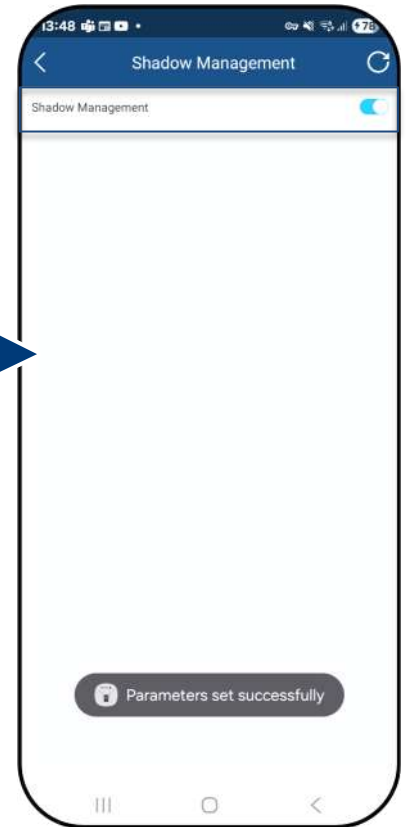

Fig. 96. Activate shadow management

### 9.8.4 Authorisation to change parameters

<Live values and settings> menu has been opened from <Available communication units> and <Find inverter>

1. Open <Parameter Setup> to set the parameters for initial start-up.

**Important: No password is required for initial Parameter Setup.**

A passcode must be entered if it becomes necessary to change the parameters of the device after initial start-up (security function). The specific passcode for the inverter must be requested from KACO Service.

2. Enter the passcode in the <passcode> field and confirm with <Confirm>.

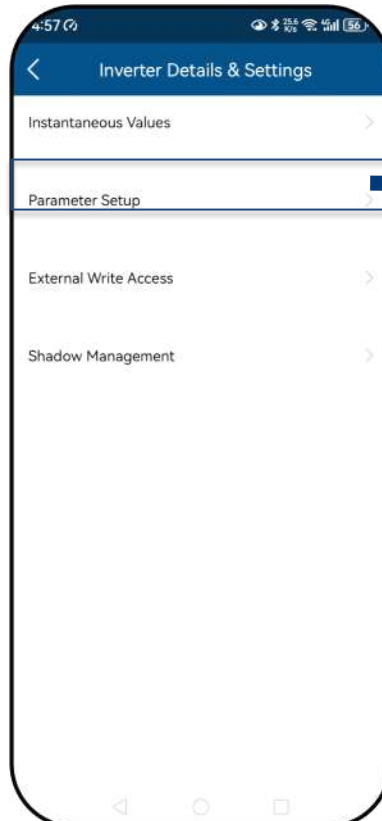
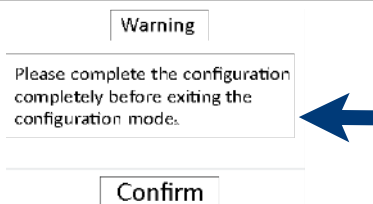

Fig. 98. Select parameter settings

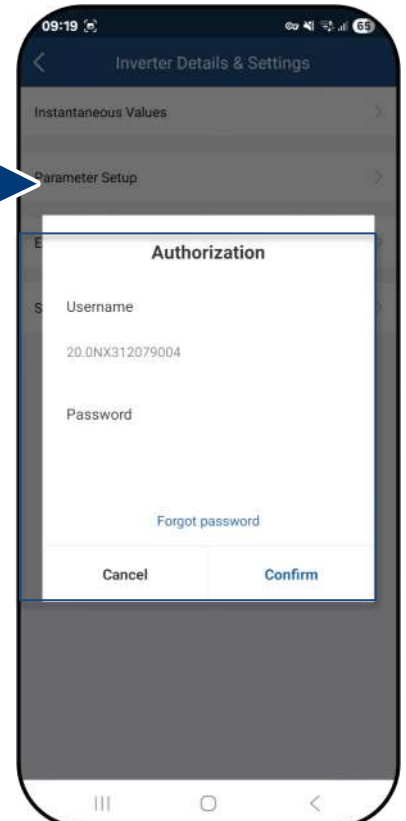

Fig. 99. Authorisation required

Fig. 97. Warning issued only on the first accidental abort attempt.

## 9.9 Service Configuration (Installer)

### 9.9.1 Selecting country and grid type

🔄 The required device is selected in <Available inverters> and the <Settings for> menu is opened in the <Parameter Setup> in the <Inverter Details & Settings> menu.

1. Select <Country/Grid Code >.

**Caution:** The following settings can only be made once without a password during initial start-up!

2. Select the operator country and grid type in the field according to the grid operator requirements and confirm with <Confirm>.

**Note:** By default, all required parameters are activated via the relevant grid code.

**Note:** When the grid standard has been changed, the device carries out a self-test. As a result, around 2 minutes may elapse before the device feeds in again.

**Note:** Further grid standards settings can be made if requested by the grid operator or customer (e.g. setting for reactive power, Q(U) curve, see Chapter 9.12).

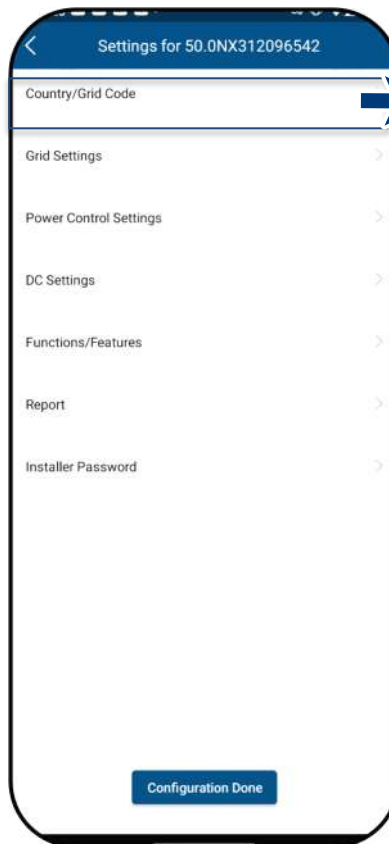

Fig. 100. Check or change country and grid-type

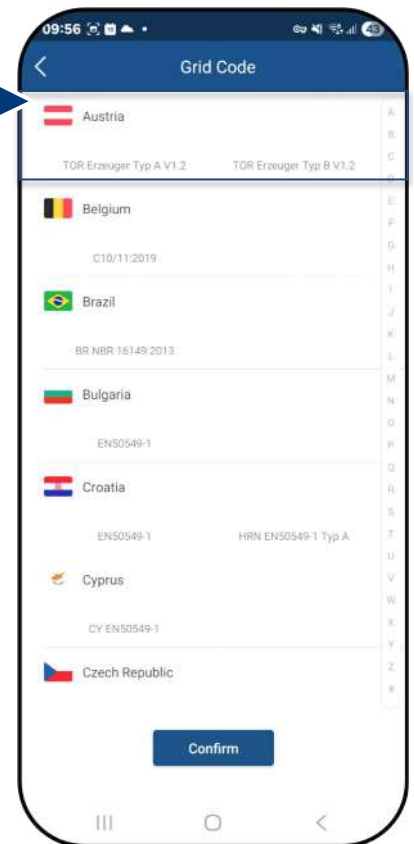

Fig. 101. Select country & grid code and grid-type

### 9.9.2 Enabling functions



#### NOTE

You will find a description of the individual functions starting in Chapter 9.12.1 from page 50. Further parameters are also being added continuously in the successive firmware versions. For this reason, see the PDF version of these application instructions for important additions.

🔄 The <Communication device > menu is opened.

1. Call up <Functions>.

2. After the setting has been made in the respective parameter, the function can be enabled (see references).

- 70 % Active power Control (for details, see Chapter 9.14.2 below on page on page 71)
- Active power ramp (see Chapter 9.12.7 on page 54)
- P(U) (see Chapter 9.12.9 on page 59)
- P(f) (see Chapter 9.12.8 on page 55)
- Reactive power control (see Chapter 9.12.10 on page 60)
- Trip Overvoltage (10min Average)– protective function
- Active power increase at underfrequency P(f) configuration

3. Confirm selection with < Confirm>. The device then performs a restart with the desired range of functions.

» The desired functions are permanently set.

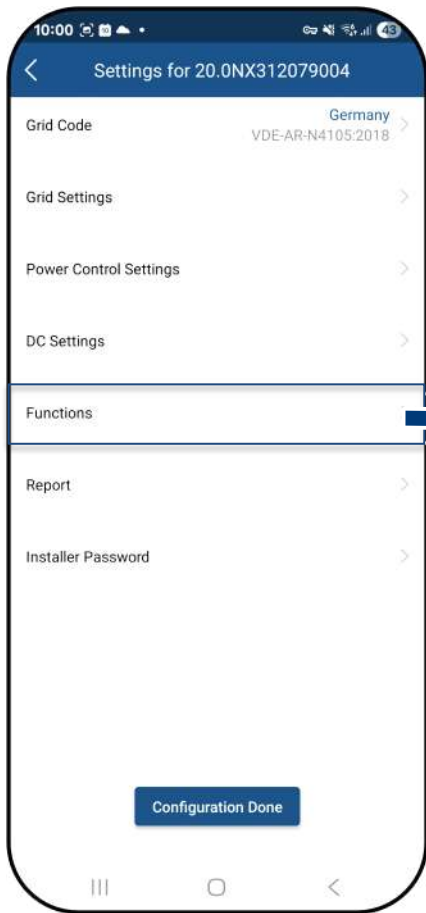

Fig. 102. Select inverter

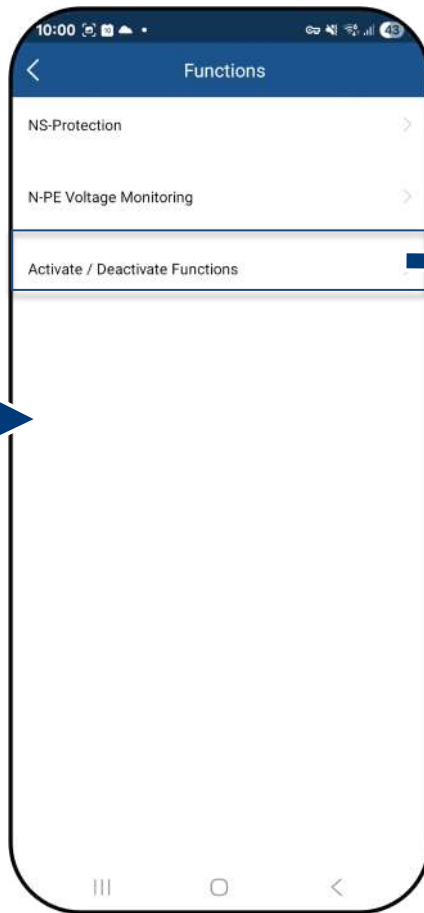

Fig. 103. Activate functions



Fig. 104. Toggle required functions

### 9.9.3 NS-Protection

**Note:** If grid & system protection is connected to the "COM4" or "COM5" port, this protective device must be activated. A digital signal must be present for the inverter to start feeding into the grid

🔄 The <Settings for> menu is opened.

1. Activate <NS protection> if an external protective device is connected (e.g. Powador-Protect, Ziehl, Bender...)

» Device is monitored by NS protection device



Fig. 105. Select NA protection

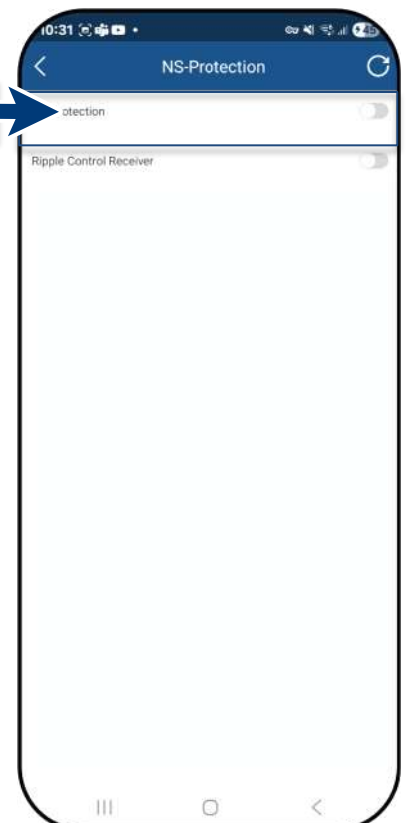

Fig. 106. Activate mains & system protection

### 9.9.4 Ripple Control Receiver

**Note:** If a ripple control receiver is present, it must be activated. When activated, the grid operator is allowed to regulate the feed-in power by sending digital signals directly to the device or via an external interface. The ripple control receiver can coexist with an external power controller (e.g., data logger). In this case, the device continuously updates itself and prioritizes the signal with the lower power limitation.

🔄 The <NA-Protection> menu is opened.

1. If necessary, activate the ripple control receiver.

**Note:** If no digital RCR signal is received at the device input, this is interpreted as an RCR 100% power signal.

» Device is connected to the ripple control receiver.



Fig. 107. Select NA protection

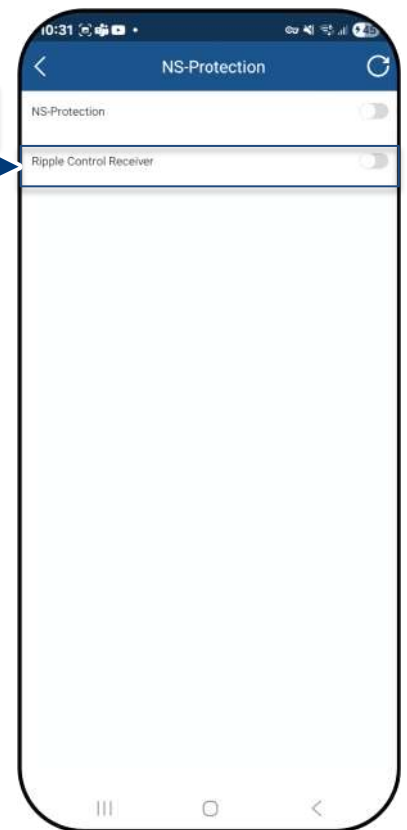

Fig. 108. Activate ripple control receiver

### 9.9.5 N-PE Voltage Monitoring

**Note:** Monitors the voltage between neutral conductor and protective earth. If deviations occur, an error is reported.

🔄 The menu <Setting for> is open.

1. Activate >N-PE voltage monitoring< if the neutral conductor is connected.

» Monitoring activated.



Fig. 109. Monitoring Voltage N-PE

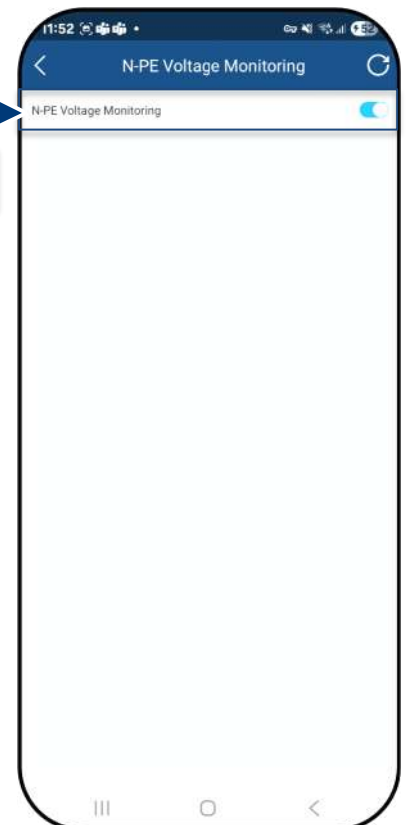

Fig. 110. Activate N-PE monitoring

### 9.9.6 Grid settings

**Note:** In the **Grid Settings** menu, you configure all the parameters that govern the interaction between the inverter and the power grid.

↻ The <Settings for> menu is open.

1. Select <Grid Settings> to configure the basic grid-connection parameters.

» All settings must be logged by the grid operator to ensure the device is safely integrated into the network.

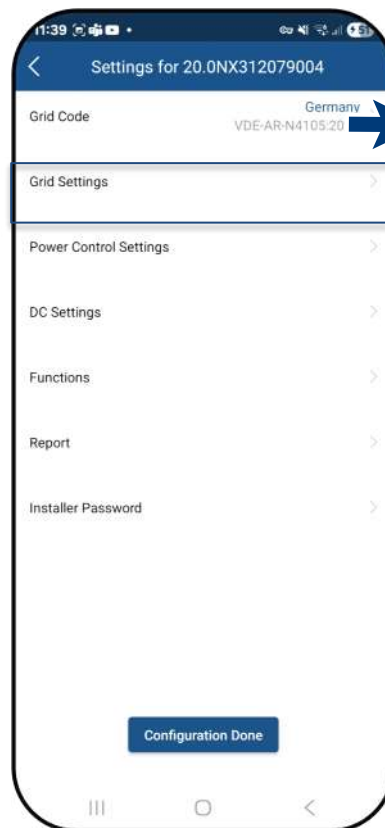

Fig. 111. Select voltage shutdown settings

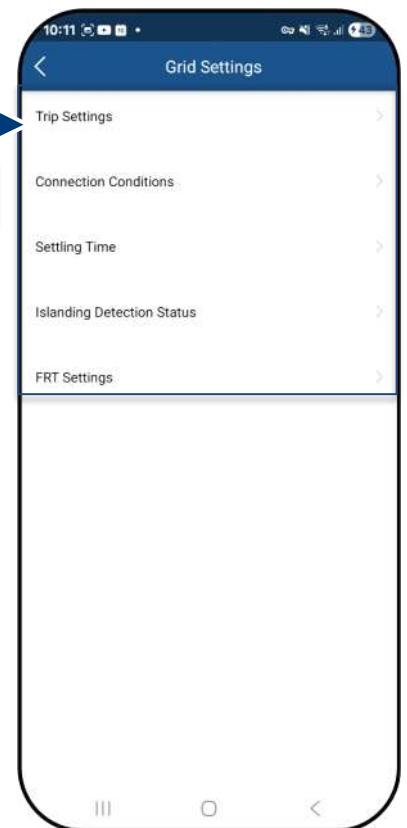

Fig. 112. Define voltage range and shutdown settings

### 9.9.7 Frequency shutdown settings

**Note:** There are three thresholds for overfrequency and underfrequency protection. The first threshold value indicates the lower range. The middle threshold range is freely adjustable. The third threshold value indicates the upper range.

↻ The <Settings for> menu is opened.

1 Select <Trip Frequency Settings>.

2. Set the thresholds.

Principle:

- Trip Overfrequency Level 1 ≤ Trip Overfrequency Level 2 ≤ Trip Overfrequency Level 3
- Trip Underfrequency Level 1 ≥ Trip Underfrequency Level 2 ≥ Trip Underfrequency Level 3
- Trip Time Level 1 ≥ Trip Time Level 2 ≥ Trip Time Level 3

3. Save settings with <Confirm>.

» Frequency protection defined.



Fig. 113. Select frequency shutdown settings

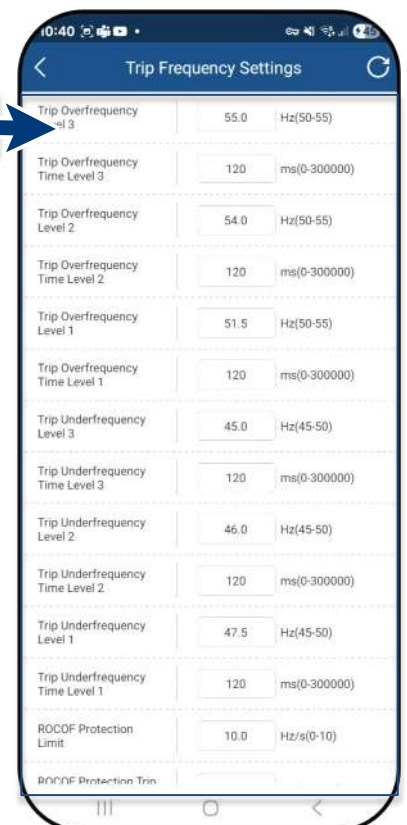

Fig. 114. Set frequency range and ROCOF protection limit

### 9.9.8 Voltage shutdown settings

**Note:** There are three thresholds for overvoltage and undervoltage protection. The first threshold value indicates the lower range. The middle threshold range is freely adjustable. The third threshold value indicates the upper range.

↻ The <Settings for> menu is opened.

1. Select <Trip Voltage Settings>.
  2. Set min. and max. shutdown time with associated voltage for each phase.
  3. Save the settings with the <Confirm> button.
- » Voltage protection defined.

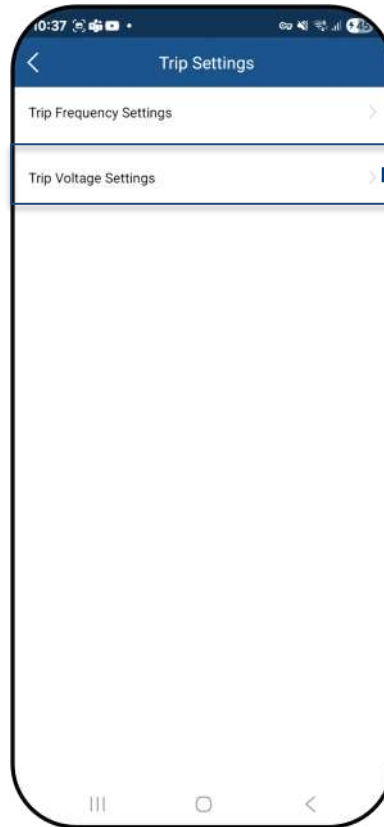

Fig. 115. Select voltage shutdown settings



Fig. 116. Define voltage range and shutdown times

### 9.9.9 Connection Conditions

**Note:** Set monitoring time when one of the voltage and frequency values has been changed. If the measured values are within the range defined by the selected grid standard, the inverter can start or reconnect.

↻ The <Settings for> menu is opened.

1. Select <Connection Time Settings>.
  2. Set <Start Connect Time> for restart.
  3. Set <Reconnect Time>.
  4. <Confirm> settings.
- » Connection time defined.

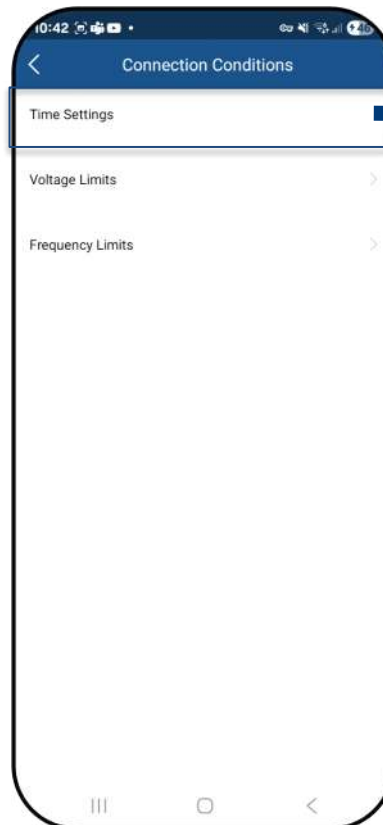

Fig. 117. Select connection time settings

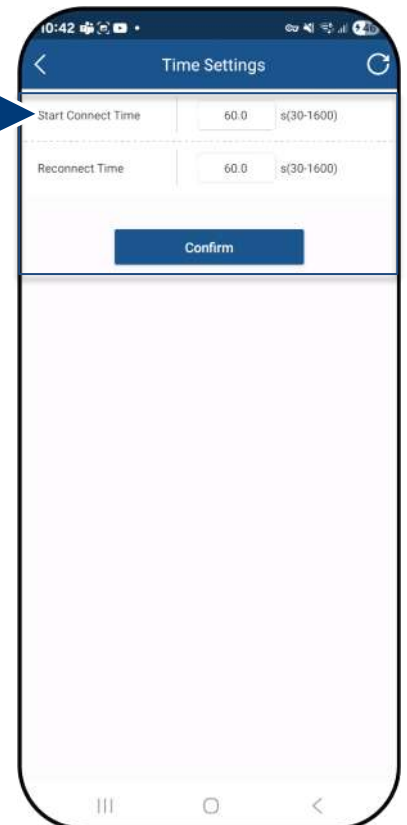

Fig. 118. Define start-up / reconnection time

### 9.9.10 Connection Conditions

**Note:** The suitable voltage and frequency range for grid operation can be set in accordance with the requirements of the local grid operator.

↻ The <Connection Conditions> menu is opened.

1. Select <Voltage Limits or <Frequency Limits>.
2. Set parameters for min./max. start voltage and start frequency.
3. Save settings with <Confirm>.
- » Connection conditions defined.

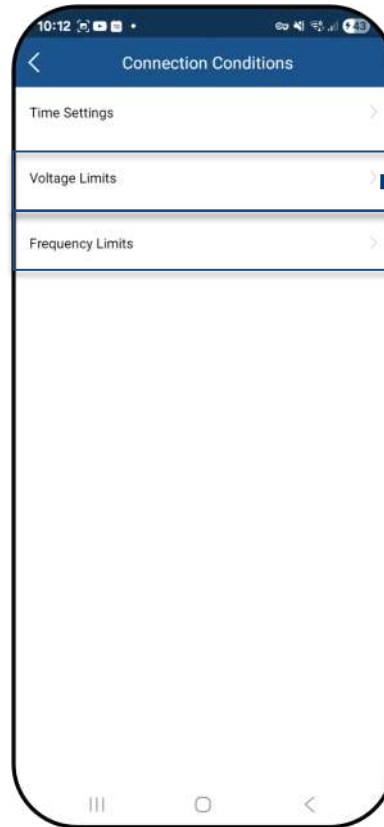

Fig. 119. Connection conditions



Fig. 120. Setting limits

### 9.9.11 Settling time

**Note:** Set the response speed for active and reactive power setpoint changes.

↻ The <Settling Time> menu from >grid settings> is open.

1. Select <Active Power Settling Time>. **Note:** This is the time the system needs to adjust its active power (P) to a new setpoint (e.g., via remote signal or grid change).

2. Enter the desired <Active Power Settling Time>.

3. Save your changes by selecting <Confirm>.

4. Select <Reactive Power Response Time>. **Note:** This is the delay from a voltage change or control signal until the system begins to deliver the specified reactive power (Q).

5. Enter the desired <Reactive Power Response Time>.

- » Save your changes by selecting <Confirm>.

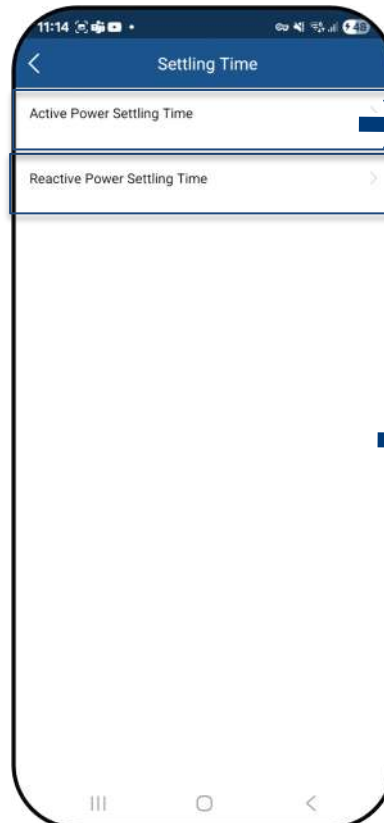

Fig. 121. Choose Settling time

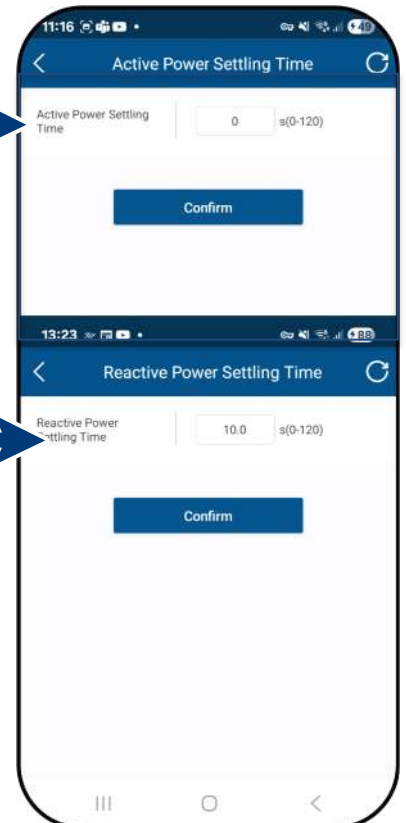

Fig. 122. P & Q define settling time

### 9.9.12 Islanding Detection Status

**Note:** Further protective settings must also be made to protect your PV array from damage.

↻ The <Grid Settings> menu is opened.

1. Set the <Activate Islanding Detection Status>. It operates from normal grid values (RMS V, frequency ROCOF, Frequency shift).

2. Save settings with <Confirm>.

» Protective function set

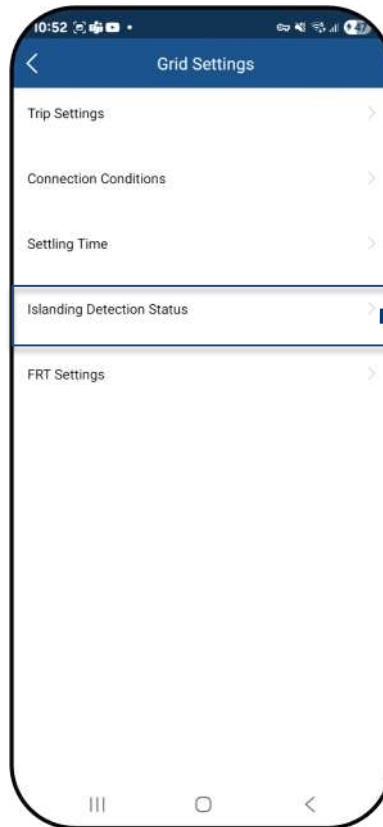

Fig. 123. Call up other protective shutdowns

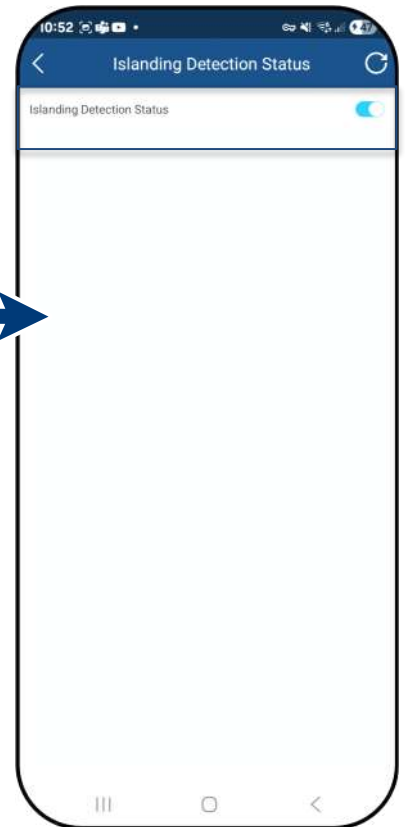

Fig. 124. Set insulation resistance and DC parameters

### 9.9.13 FRT Settings

**Note:** The device supports dynamic grid stabilization (fault-ride-through of grid disturbances).

**LVRT:** The PV system remains connected even if grid voltage dips severely for a short time (e.g., during a nearby short circuit).

**HVRT:** The PV system remains connected even if grid voltage rises above nominal for a short time (e.g., due to a sudden load drop or grid fault).

↻ The <Grid Settings> menu is open..

1. Configure the LVRT and HVRT parameters according to the national regulatory requirements. Refer to the notes for each parameter in Section 9.9.14 & 9.9.15

2. Save the settings by selecting <Confirm>.

» Protective function configured

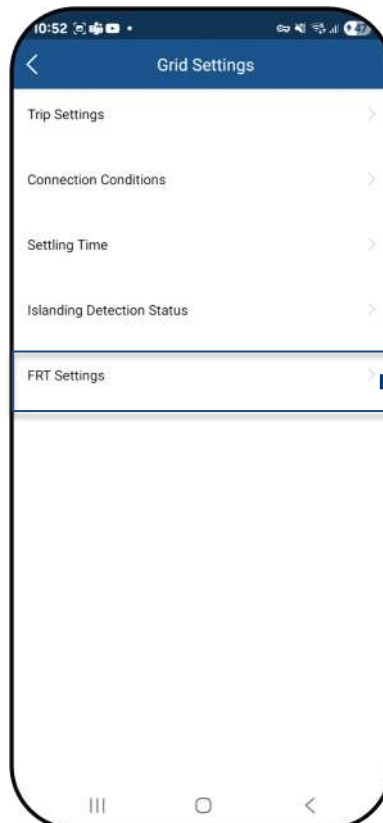

Fig. 125. Choose FRT-Settings

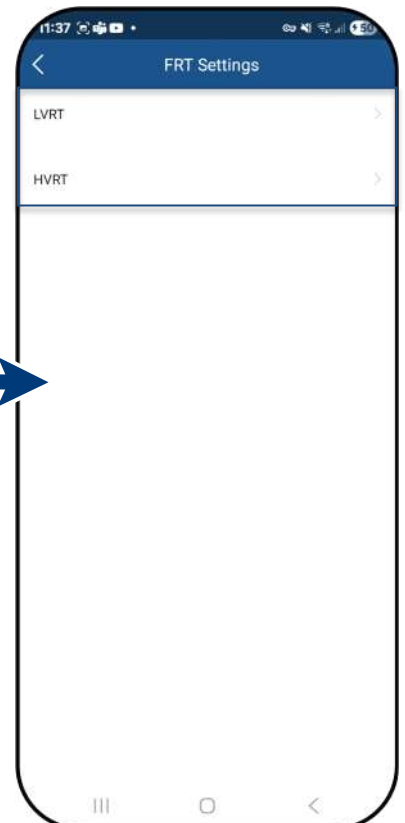

Fig. 126. Choose LVRT or HVRT

### 9.9.14 Inverter dynamic network stability setting: LVRT

**Note:** Displays all set parameters in an overview list.

↻ The <Settings for> menu is opened.

1. Select <LVRT>.

2. Check all set parameters.

**Note:** The additional reactive current should be provided for voltage supporting and it can be chosen according to different standard.

**Note:** The active current mode during the LVRT also can be chosen according to different standard.

Note: Some special standards maybe need set the additional reactive current to different value for the asymmetrical failure and symmetrical failure.

**Note:** The voltage type for activation threshold can be chosen as line-to-line voltage, phase to phase voltage or positive sequence voltage.

**Note:** The activation threshold for voltage sudden change and voltage dips can be set as the percent of the rated voltage. The activation threshold for the additional to the requirements for the zero current mode can be set as the percent of the rated voltage.

**Note:** The gradient k factor can be configurable in the range of 0 – 10.

» Parameter overview displayed.

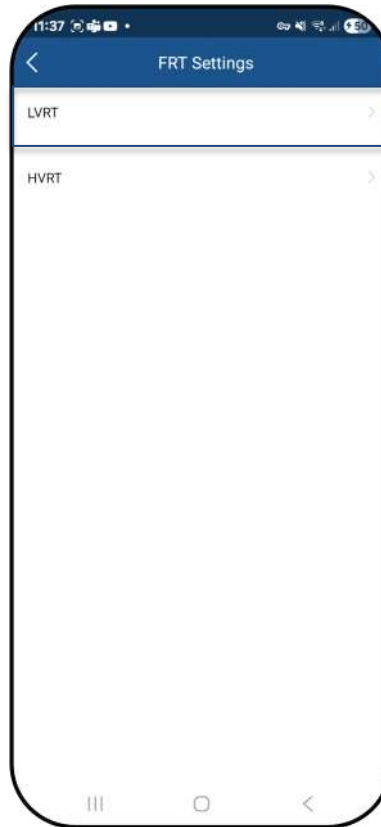

Fig. 127. Select LVRT

Fig. 128. Set LVRT parameters

### 9.9.15 Inverter dynamic network stability setting: HVRT

**Note:** Displays all set parameters in an overview list.

↻ The <Settings for> menu is opened.

1. Select <HVRT>.

2. Check all set parameters.

**Note:** The additional reactive current should be provided for voltage supporting and it can be chosen according to different standard.

**Note:** The active current mode during the HVRT also can be chosen according to different standard.

**Note:** Some special standards maybe need set the additional reactive current to different value for the asymmetrical failure and symmetrical failure.

**Note:** The voltage type for activation threshold can be chosen as line to line voltage, phase to phase voltage or positive sequence voltage.

**Note:** The activation threshold for voltage sudden change and voltage raise can be set as the percent of the rated voltage. The activation threshold for the additional to the requirements for the zero current mode can be set as the percent of the rated voltage.

**Note:** The gradient k factor can be configurable in the range of 0 – 10.

» Parameter overview displayed.



Fig. 129. Select HVRT

Fig. 130. Set HVRT parameters

### 9.9.16 P(f) settings

**Note:** With a programmable frequency threshold with programmable P range, the inverter can activate the active power response to underfrequency.

The <Settings for> menu is opened.

1. Select the <P(f) Settings>.
  2. Select mode > see note below on the 4 modes.
  3. Define frequency range.
  4. Set Relative power reduction.
  5. Set internal delay time P(f).
  6. Define Min. delay time for Power reduction.
  7. Define power gradient after resetting the frequency.
- » P(f) defined.

**Legend for Fig. 124+Fig. 125:**

$f_n$ : Nominal frequency;  $f_{reset}$ : Reset frequency;  
 $f_{start}$ : Start frequency;  $f_{stop}$ : Stop frequency;  
 $\Delta P$ : Active power in % during reduction

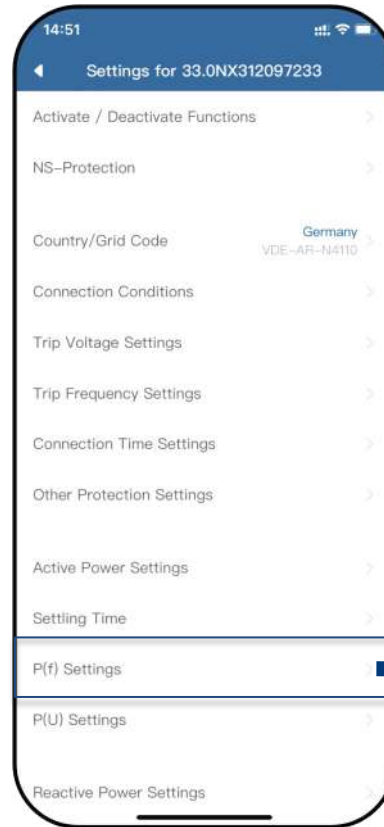

Fig. 131. Select the P(f) settings



Fig. 132. Set the P(f) parameters

**Note:** The following 4 modes are available for selection:

1. Fixed gradient and non-hysteresis:  $\Delta P$  is the active power as a percentage of  $P_n$ ; the inverter provides non-hysteresis in the control of active power response to overfrequency
2. Variable gradient and non-hysteresis:  $\Delta P$  is the active power as a percentage of  $P_M$ ; the inverter provides non-hysteresis in the control of active power response to overfrequency.
3. Fix gradient and hysteresis:  $\Delta P$  is the active power as a percentage of  $P_n$ ; the inverter provides hysteresis in the control of active power response to overfrequency
4. Variable gradient and hysteresis:  $\Delta P$  is the active power as a percentage of the  $P_M$ ; the inverter provides hysteresis in the control of active power response to overfrequency.

**Note:** The intentional delay time for P(f) is only used for the activation of the function in accordance with the frequency via  $f_{start}$ , whereby the intentional delay time plus own dead time must be smaller than 2s.

**Note:** The minimum delay time for enabling of the active power is the delay time during which the active power can increase once the frequency has fallen below  $f_{reset}$ .

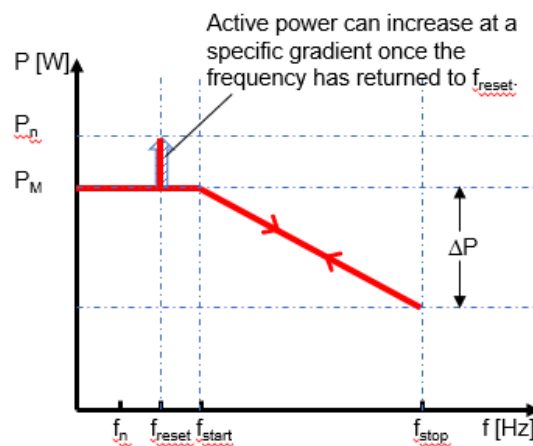

Fig. 133. Non-hysteresis

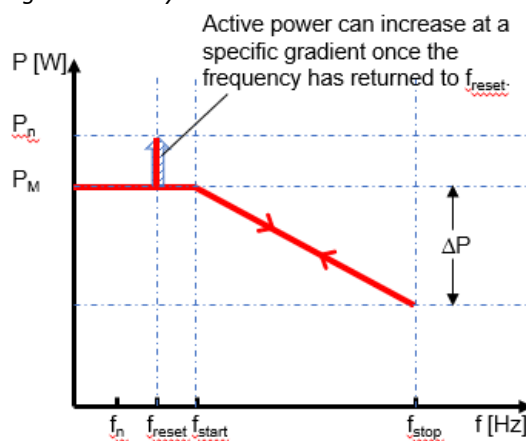

Fig. 134. Hysteresis

### 9.9.17 P(U) settings

**Note:** With a programmable voltage threshold with programmable P range, the inverter can activate the active power response to overvoltage.

⌚ The <Settings for> menu is opened.

1. Select the <P(U) Settings>.
  2. Select mode > see note below
  3. Define voltage range.
  4. Define relative power reduction.
  5. Set internal delay time P(U).
  6. Define Min. delay time for power reduction.
  7. Define power gradient after resetting the frequency.
- » P(U) defined.

**Legend for Fig. 128+ Fig. 129**

$U_n$ : Nominal voltage;  $U_{reset}$ : Reset voltage;  
 $U_{start}$ : Start voltage;  $U_{stop}$ : Stop voltage;  
 $\Delta P$ : Active power in % during reduction.

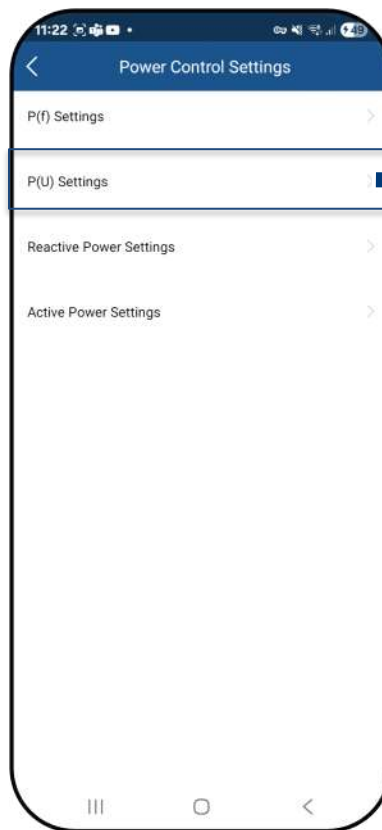

Fig. 135. Select the P(U) settings

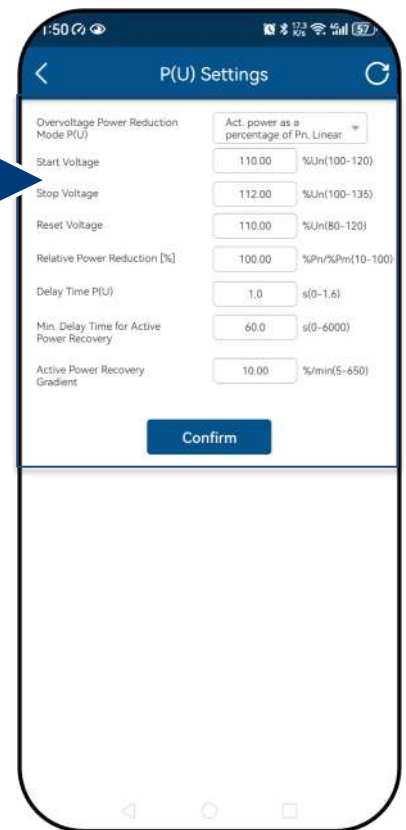

Fig. 136. Set the P(U) parameters

**Note:** The following 4 modes are available for selection:

1. Fix gradient and non-hysteresis:  $\Delta P$  is the active power as a percentage of  $P_n$ ; the inverter provides non-hysteresis in the control of active power response to overvoltage.
2. Variable gradient and non-hysteresis:  $\Delta P$  is the active power as a percentage of the  $P_M$ ; the inverter provides non-hysteresis in the control of active power response to overvoltage.
3. Fix gradient and hysteresis:  $\Delta P$  is the active power as a percentage of  $P_n$ ; the inverter provides hysteresis in the control of active power response to overvoltage.
4. Variable gradient and hysteresis:  $\Delta P$  is the active power as a percentage of the  $P_M$ ; the inverter provides hysteresis in the control of active power response to overvoltage.

**Note:** The intentional delay time for P(U) is only used for the activation of the function in accordance with the voltage via  $U_{start}$ , whereby the intentional delay time plus own dead time must be smaller than 2s.

**Note:** The minimum delay time for enabling of the active power is the delay time during which the active power can increase once the voltage has fallen below  $U_{reset}$ .

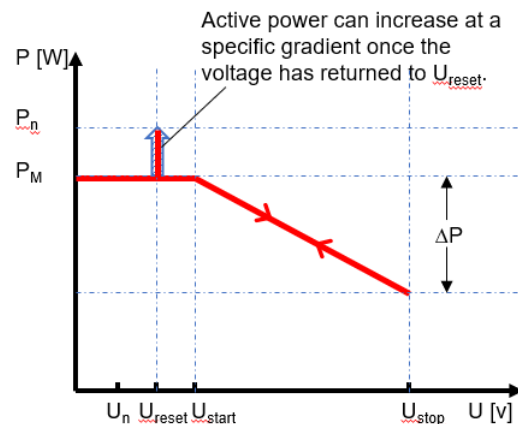

Fig. 137. Non-hysteresis

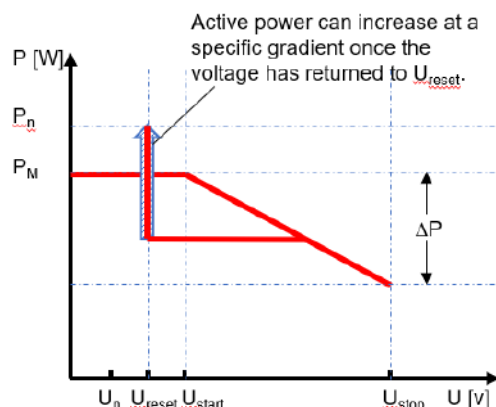

Fig. 138. Hysteresis

### 9.9.18 Reactive power operation mode

**Note:** Reactive power can be used in electrical energy supply networks to bolster the level of voltage. As such, feed-in inverters can contribute to statistical voltage stability.

↻ The <Settings for> menu is opened.

1. Select <Reactive Power Settings>.
2. Select control process > see basis and set subsequent processes <Cos-phi Constant>, <Cos-phi(P)>, <Q Constant>, <Q(U)>.
3. Set <Settling Time> for selected control process.

**Note:** A change in the reactive power may be necessary in order to meet the requirements of a first-order filter.

» Reactive power process defined.

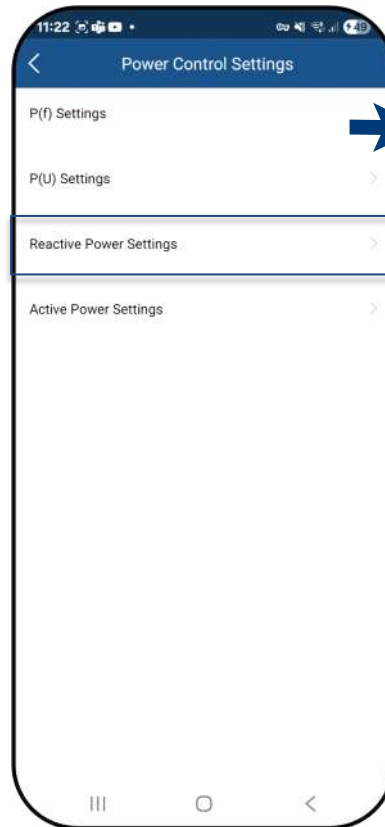

Fig. 139. Select reactive power settings

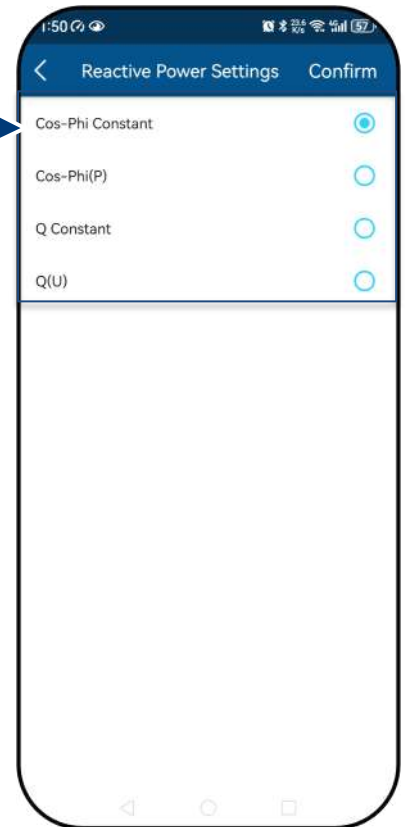

Fig. 140. Specify the operation mode settings

#### Basis

There are four types of reactive power control. Only one mode of operation can be active at any given moment.

From the perspective of the grid, the inverter behaves like a load in accordance with the national standard. This means that the inverter operates in quadrant II (under-excited) or III (over-excited) as shown in Fig. 133

#### Definition

Over-excited reactive power, also known as capacitive reactive power or leading power factor.

Under-excited reactive power, also known as inductive reactive power or lagging power factor.

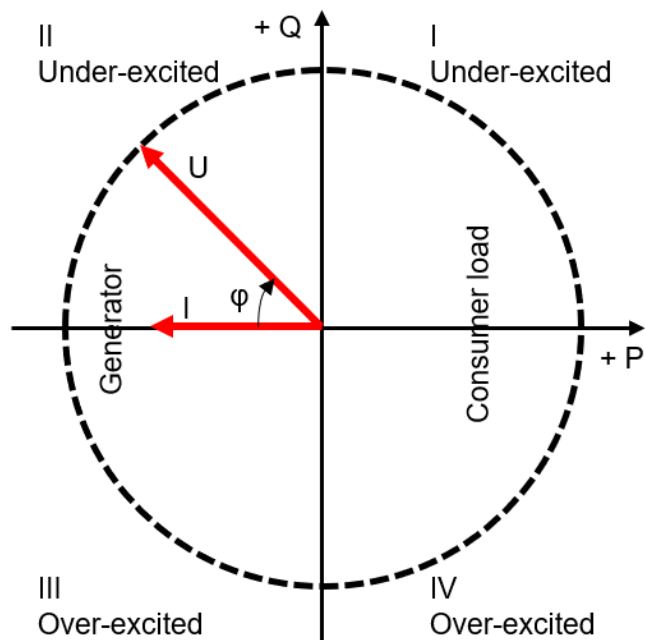

Fig. 141. Load reference arrow system

### 9.9.19 Cos-phi constant settings

**Note:** In cos  $\phi$  constant mode, the specified power factor is permanently set by the inverter. In doing so, the reactive power level is set in line with  $Q=P*\tan \phi$  as a function of the power that continuously generates the specified power factor.

The <Settings for> menu is opened.

1. Select <Cos-phi Constant setting>.
  2. Set the <Cos-phi> target value.
  3. Select the excitation type from the drop-down field.
  4. Save settings with <Confirm>.
- » Cos-phi constant defined.

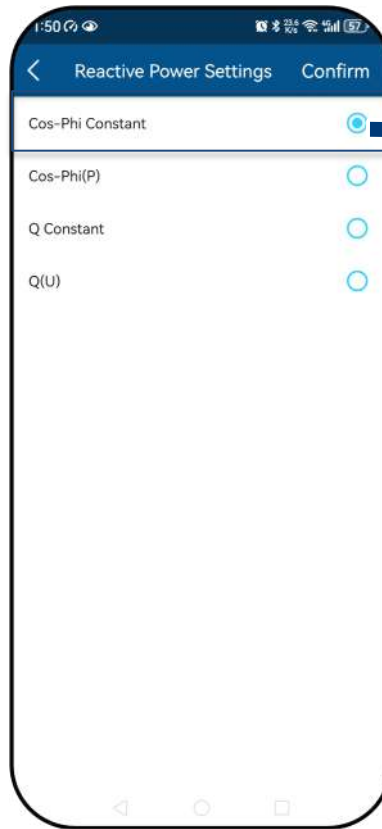

Fig. 142. Select the cos-phi constant

Fig. 143. Define the cos-phi target value

### 9.9.20 Q constant settings

**Note:** The target value of the reactive power can be adjusted depending on the set maximum apparent power.

The <Settings for> menu is opened.

1. Select <Q Constant settings>.
  2. Set <Q> in %.
  3. Select the excitation type from the drop-down field.
  4. Save settings with <Confirm>.
- » Q constant> defined.

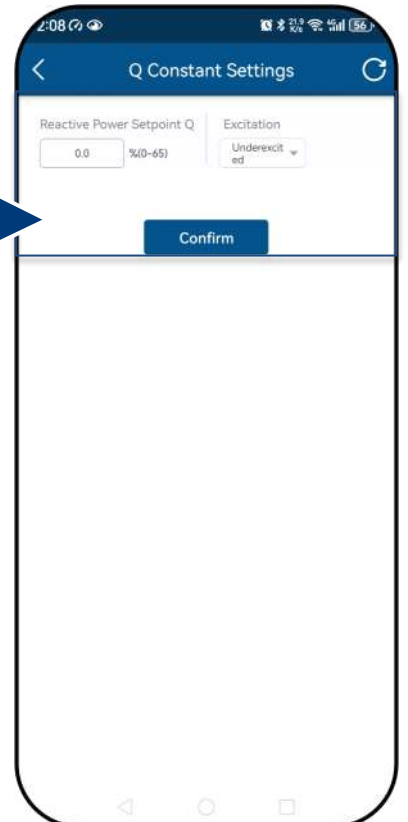
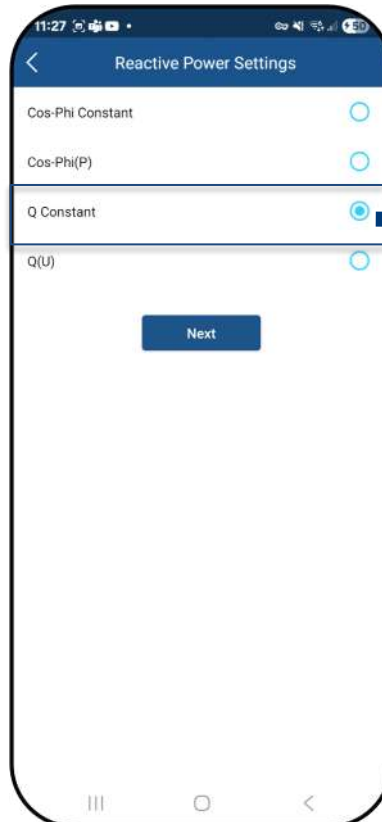

Fig. 144. Select Q constant settings

Fig. 145. Enter reactive power target value Q

### 9.9.21 Cos-phi (P) settings

**Note:** Power-based control  $\cos \phi(P)$  regulates the  $\cos \phi$  value of the power depending on the emitted active power.

4 coordinates can be set in order to map the P curve.

↻ The <Settings for> menu is opened.

1. Select <Cos-phi (P) settings>.

2. Define  $P/P_n$ ,  $\cos\phi$  and excitation for each of the 4 nodes.

3. Set the <Activation voltage>.

**Note:** Activation threshold as a percentage of  $U_n$  corresponds to the “Lock-In” voltage.

4. Set the <Deactivation Voltage>.

**Note:** Deactivation threshold as a percentage of  $U_n$  corresponds to the “Lock-Out” voltage.

»  $\cos \phi(P)$  defined.

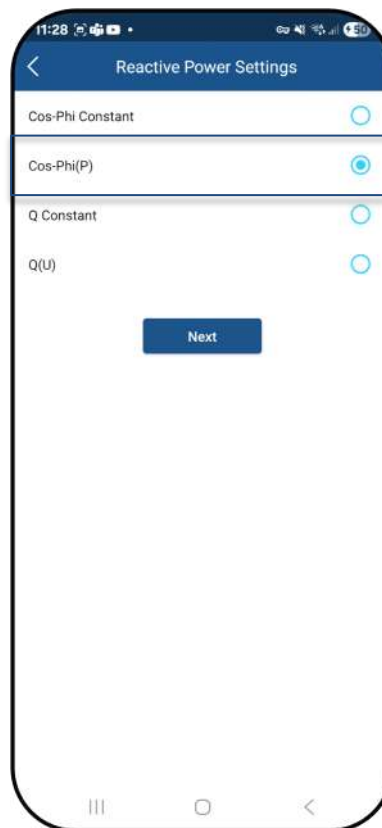

Fig. 146. Select cos-phi (P) settings



Fig. 147. Set cos-phi (P) parameters

**Definition:**

The coordinates are the active power as a percentage of  $P_n$  and the displacement factor  $\cos\phi$ .

A grid operator can specify two voltage thresholds as a percentage of  $P_n$  to activate or deactivate the function. The voltage thresholds are normally referred to as the “Lock-In” and the “Lock-Out” voltage.

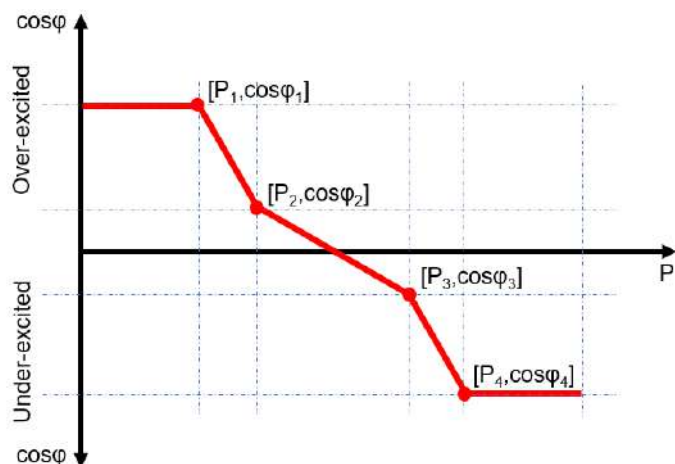

Fig. 148. Cos-phi(P) curve

### 9.9.22 Q(U) settings

**Note:** Voltage-dependent control Q(U) regulates the reactive power output depending on the voltage. 4 coordinates can be set in order to map the curve.

⌚ The <Settings for> menu is opened.

1. Select the <Q(U) settings>.
2. Define  $U/U_n$ ,  $Q/S_n$  and phase for each of the 4 coordinates.

3. Set the <Activation power> in % of  $P_n$ .

**Note:** Activation threshold as a percentage of  $P_n$  corresponds to the “Lock-In” voltage.

3. Set the <Deactivation Power> in % of  $P_n$ .

**Note:** Deactivation threshold as a percentage of  $P_n$  corresponds to the “Lock-Out” voltage.

» Q(U) curve defined.

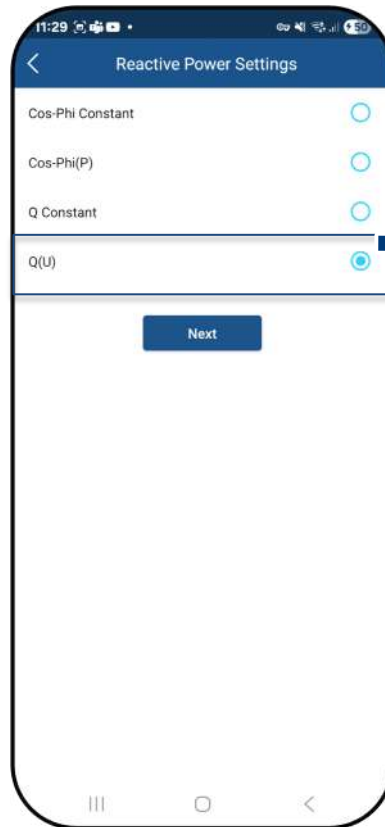

Fig. 149. Select Set Q(U) settings

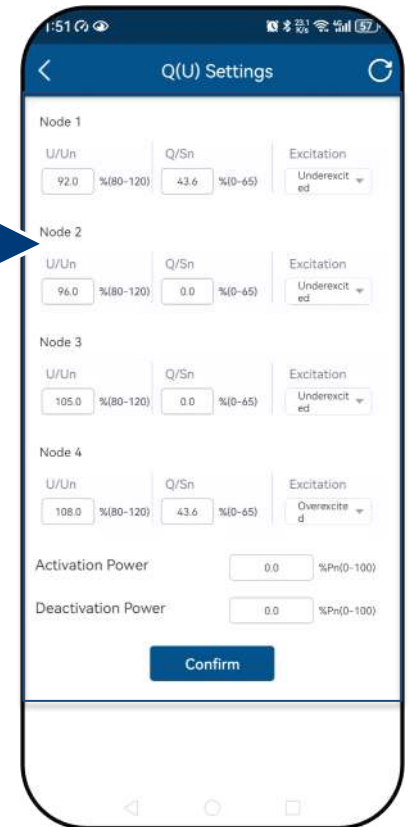

Fig. 150. Set the Q(U) parameters

**Definition:**

The coordinates are the voltage as a percentage of  $U_n$  and the reactive power as a percentage of  $P_n$ .

A grid operator can specify two active power thresholds as a percentage of  $U_n$  to activate or deactivate the function. The active power thresholds are normally referred to as the “Lock-In” and the “Lock-Out” active power.

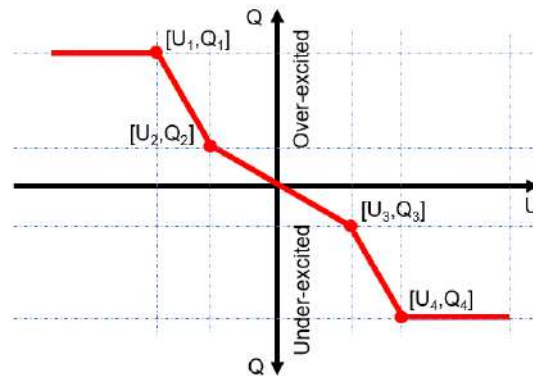

Fig. 151. Q(U) curve and non-hysteresis

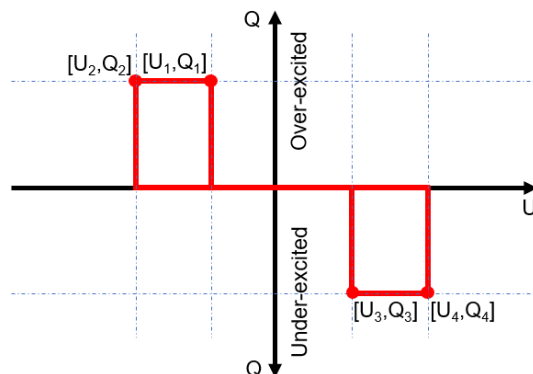

Fig. 152. Q(U) curve and hysteresis

### 9.9.23 Inverter reactive power setting: Min cos-phi for low active power (only for Austria)

**Note:** The Minimum Cos-Phi can be set during the reactive power regulation.

The <Settings for> menu is opened.

1. Select the <Min Cos-phi for Low Active Power>.

2. Set the <Min Cos-Phi for Low Active Power>.

» Min Cos-Phi is set.

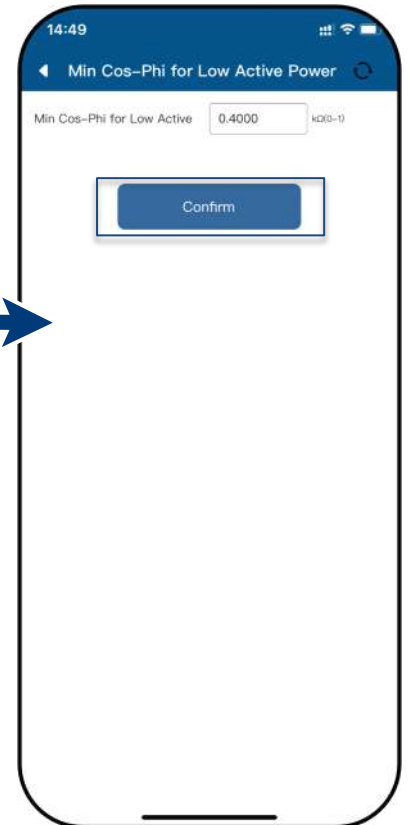
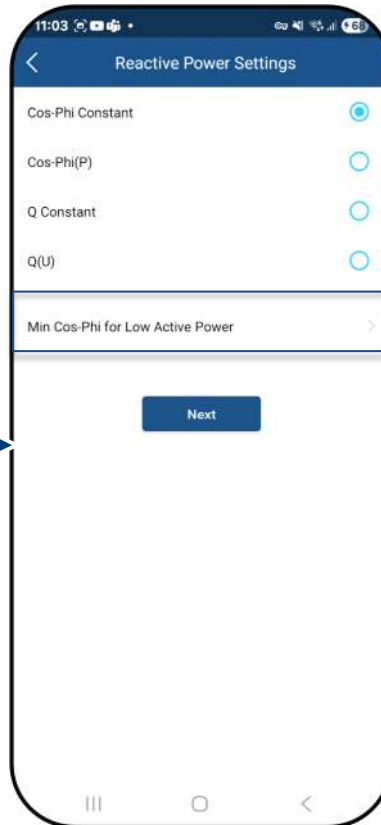

Fig. 153. Select Min Cos-Phi for Low Active Power

Fig. 154. Set Min Cos-Phi parameters

**Definition:**

The Minimum cos-phi is a limit value during the reactive power regulation. When the active power is very low, maybe the inverter can't output the required reactive power, then the inverter can output the reactive power as the minimum cos-phi.

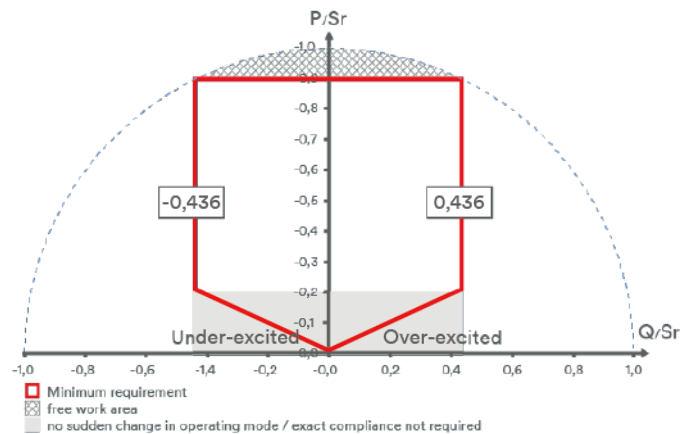

Fig. 155. Minimum cos-phi limited

### 9.9.24 Active power settings (power limitation)

**Note:** The output power of the device can be set permanently to a lower value than the maximum output power by the power limitation. This may be necessary in order to limit the maximum power rating of the system at the grid connection point, upon the grid operator's request.

↻ The <Settings for> menu is opened.

1. Select <Active power settings>.
2. Set <Max. active power> dependent on Pn in %.
3. Set the <Increasing gradient> and <Decreasing gradient> of the active power.
4. Save settings with <Confirm>.
5. Set <Settling Time> for Active power

**Note:** When switching to AC operation and control and when switching to energy generation mode, the active power generated by the device must not exceed a certain gradient expressed as a percentage of the nominal active power of the inverter per minute.

» Power limitation defined.

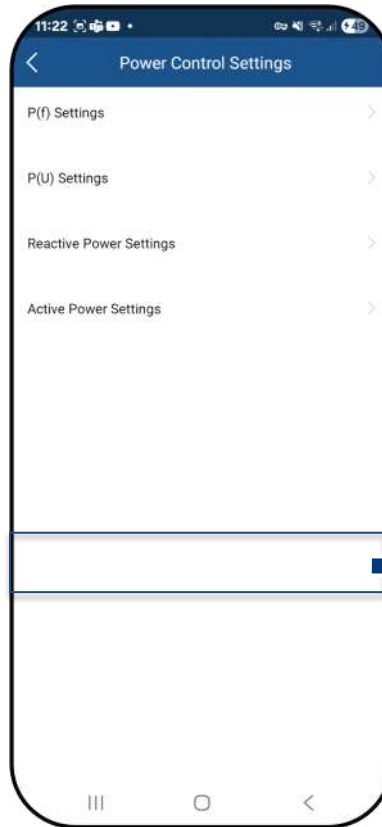

Fig. 156. Call up active power settings



Fig. 157. Define max. AP & gradients settings

### 9.9.25 DC current injection

**Note:** Further protective settings must also be made to protect your PV array from damage.

↻ The <Grid Settings> menu is opened.

1. Specify the <Min. Insulation Resistance>.
2. Specify the <Min. Insulation Resistance>.
3. Save settings with <Confirm>.

» Protective function set

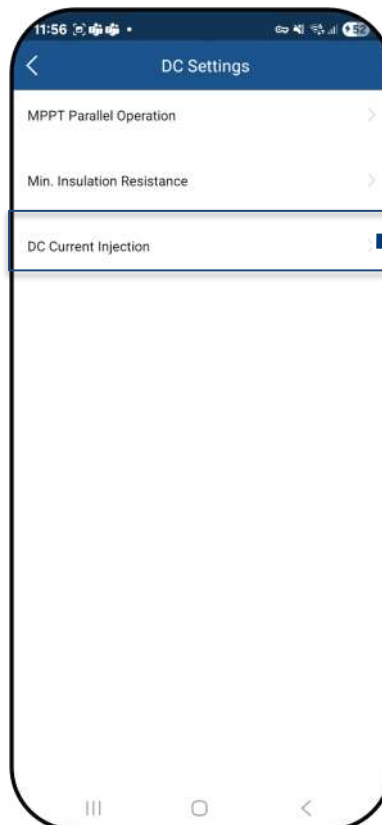

Fig. 158. Call up other protective shutdowns

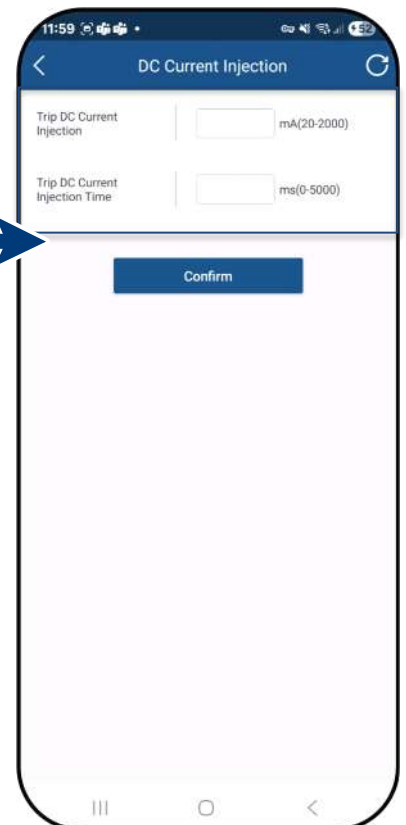

Fig. 159. Set insulation resistance and DC parameters

### 9.9.26 Min. Insulation Resistance

**Note:** Further protective settings must also be made to protect your PV array from damage.

↻ The <Grid Settings> menu is opened.

1. Specify the <Min. Insulation Resistance>.

2. Save settings with <Confirm>.

» Protective function set



Fig. 160. Call up other protective shutdowns

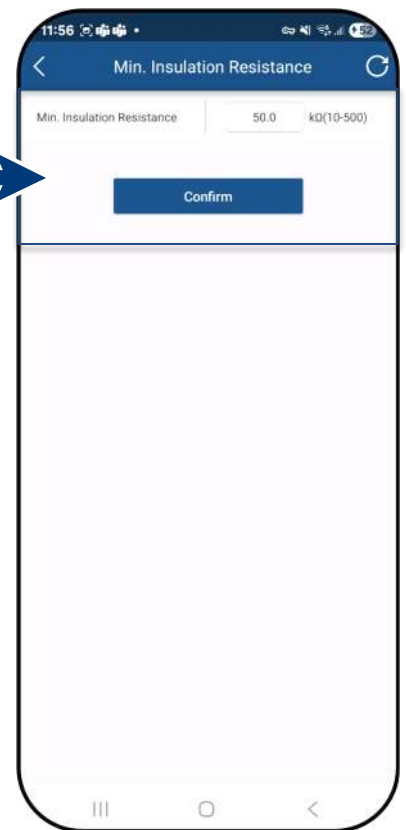

Fig. 161. Set insulation resistance and DC parameters

### 9.9.27 Inverter parameter report

**Note:** Displays all set parameters in an overview list.

↻ The <Settings for> menu is opened.

1. Select <Inverter Parameter Report>.

2. Check all set parameters.

3. Export the set parameters using the <Export PDF> button. This serves as proof of all settings made with regard to the EVU.

» Parameter overview displayed.



Fig. 162. View device parameters

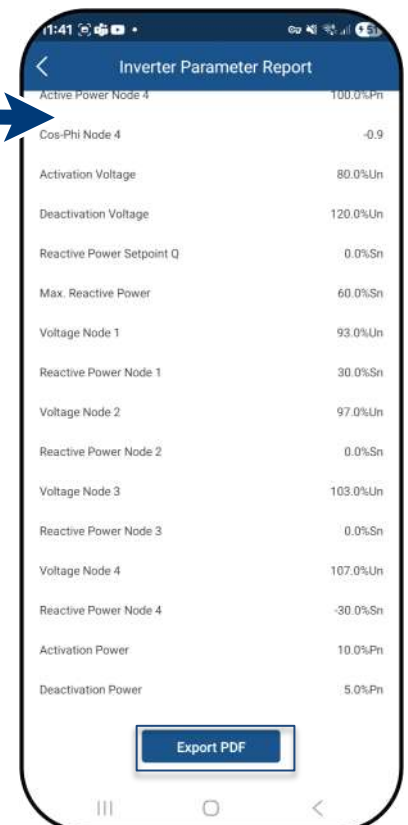

Fig. 163. View all parameters

### 9.9.28 Installer Password

**Note:** Displays all set parameters in an overview list.

↻ The <Settings for> menu is opened.

1. Select <Inverter parameter report>.

2. Check all set parameters.

3. Export the set parameters using the <Export PDF> button. This serves as proof of all settings made with regard to the EVU.

» Parameter overview displayed.

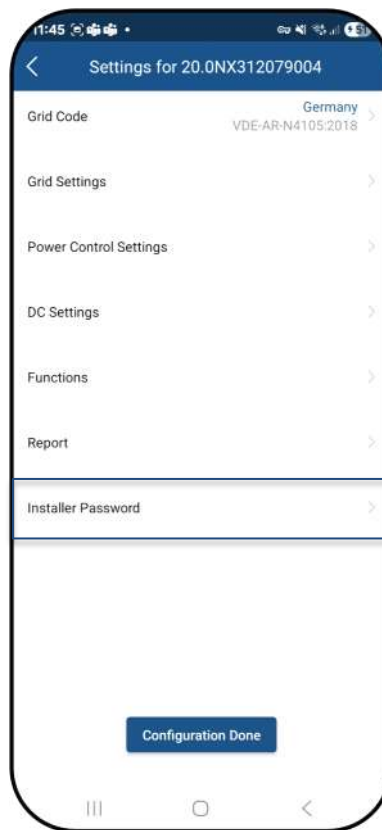

Fig. 164. View device parameters



Fig. 165. View all parameters

### 9.9.29 Password Recovery

↻ A pop-up window appears, prompting you to enter your initial password.

**Note:** If the entry is incorrect, please contact KACO Customer Service.

1. Select **Forgot Password**. A new pop-up window opens.

2. Contact KACO Customer Service. They will provide you with a device-specific password..

3. Write down the device specific password and enter it in the **Password** field..

4. Create a new password by entering it in the **New Password** field..

5. Confirm the new password by entering it again in the **Confirm Password** field..

» You can now continue adjusting parameters using your new password.

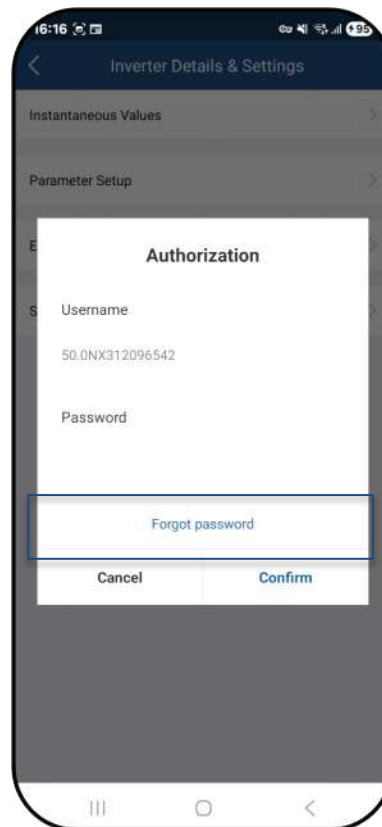

Fig. 166. Forgot password?

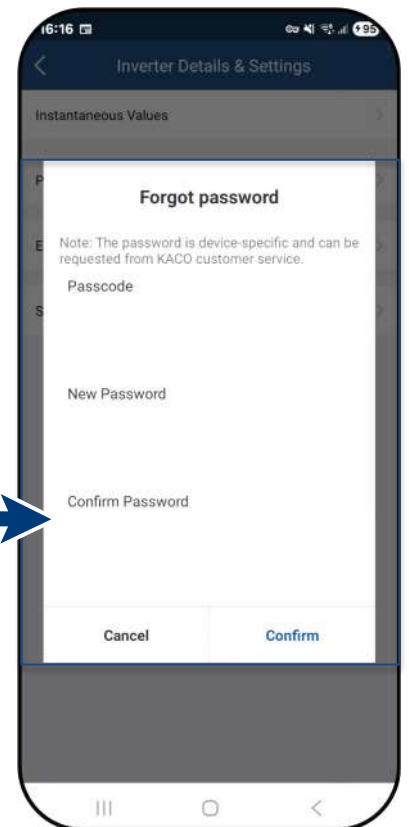

Fig. 167. Recovery password

## 9.10 Performing a Firmware-Update

### 9.10.1 Updating the Communication device

**Note:** The enclosed Communication device is required in order to perform the update. The firmware update can only be carried out with adequate DC voltage (100 W).

↻ New customer registration via the “MYKACO.COM REGISTRATION” button in the [downloads](#) section was completed successfully. Login credentials will be sent within **2** business days.

↻ The current firmware package is available under [mykaco.com](#) and does not correspond to the firmware version on the device(s).

1 Download the firmware “SW\_Package\_Vxx.zip” with the required \*.bin files from [downloads](#) under and unpack.

2. Select <Firmware Update>.

3. Select the tab < Communication Device> and press <Local Update>.

4. In the firmware path, select the new file **Update.bin**.

» After successful update, continue with the inverter firmware update.



Fig. 168. Select firmware update

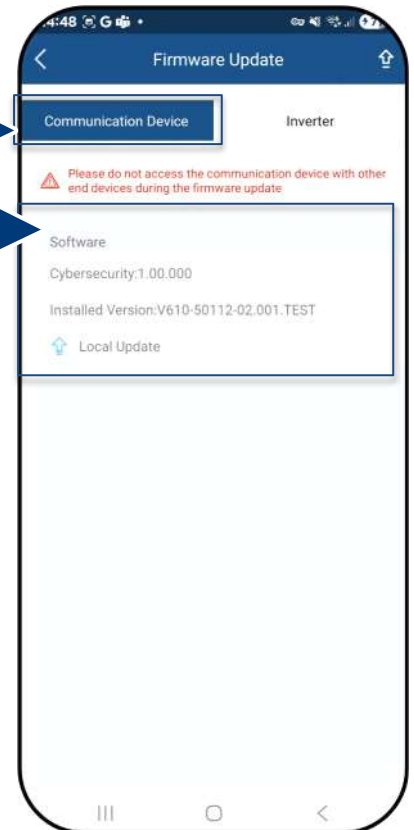

Fig. 169. Update the firmware for the Communication device

### 9.10.2 Update the inverter



#### NOTE

Make sure that there is sufficient DC power (300 W). Also note that the sequence of the firmware update for the associated \*.bin files must be observed. This process takes approx. 10 minutes. The files must not be renamed.

Before updating the inverter, the firmware of the communication device needs to be updated.



#### NOTE

With the Communication device plugged in, no communication via RS485 is possible during the firmware update.

↻ The firmware update for the Communication device has been carried out successfully.

1. Select <Firmware Update>.

2. Select the <Inverter> tab and call up <Local Update> for inverters.

3. In the firmware path, locate and open the file **masterVxxx-xxxxx-xx.bin**. The upload begins.

6. Open <Local upgrade> for the <Safety> file.

7. In the firmware path, locate and open the file **safetyVxxx-xxxxx-xx.bin**. The upload begins.

8. After completing the update, check the uploaded firmware versions of each \*.bin file against the version in your firmware path. Repeat the corresponding process if any deviation is found.

9. The upgrade process must be confirmed.

**Caution:** During the upgrade, the info – **Update in progress** – is displayed. Only **after restarting** the device does the message appear – **Update completed successfully**.

» Following successful update, the device is ready for operation.

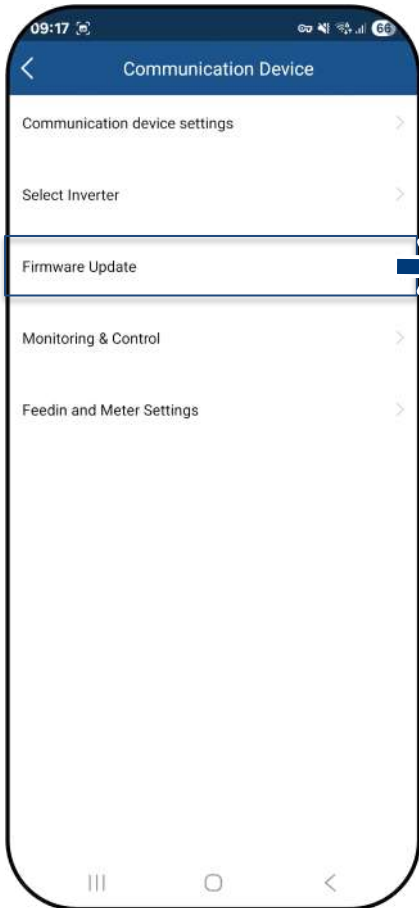

Fig. 170. Select firmware update

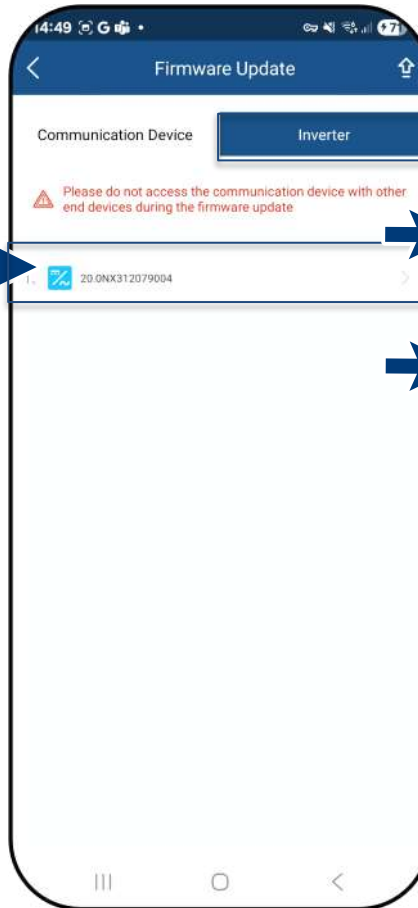

Fig. 171. Select firmware update for inverters

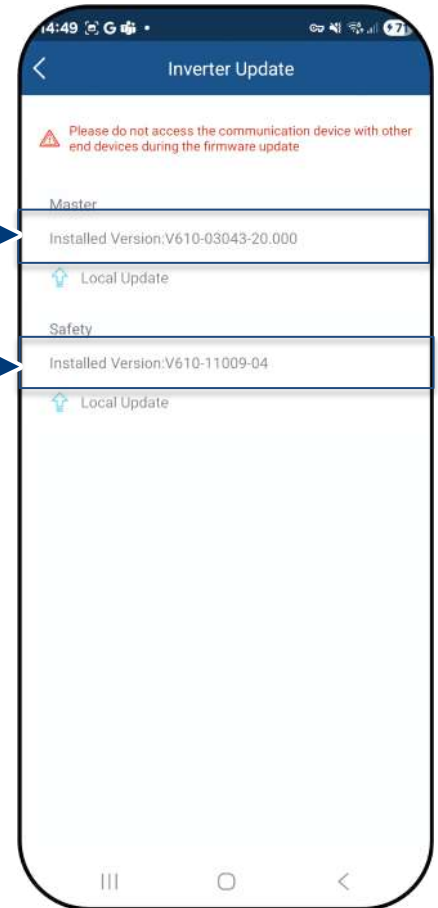

Fig. 172. Firmware for inverters and associated security update

## 9.11 Monitoring with “blueplanet web”

 <blueplanet web public> opened.

**Note:** You will find the portal under: <https://kaco-newenergy.com/de/blueplanet-web/>.

1. Select “Register PV system free of charge in blueplanet web public”.
2. From the drop-down menu, select <blueplanet NX Series>.
3. Registration is carried out via the <Create new user> button, or with an existing account via <Login>.

**Note:** Data is transferred after approx. 30-60 minutes.

**Note:** After successful connection, the LED <blueplanet Web-Status> under <Communication device > lights up **green**. (LED status – See Fig. 62).

**Note:** The portal version <blueplanet web pro>, which is subject to a charge, offers a greater range of functions

**If disruptions occur at the “meteocontrol” service provider, the device will remain in that status and wait until the PV voltage falls to around 300 W so it can still retrieve daily data if possible. On the following day, please check the web-monitor status.**

*blueplanet web public Registrierung*

Mit diesem Formular können Sie Datenlogger zur Verwendung mit blueplanet web public registrieren.

1. Klicken Sie bitte auf "Neuen Benutzer anlegen" um einen neuen Zugang anzulegen.
2. Verfügen Sie bereits über einen Login klicken Sie bitte auf "Login".

blueplanet web public Kommunikation:

---

**NOTE**

**Registration entry in the monitoring tool SW package > serial number from communication device**

▼ Data logger

Inverter serial number(s)\*:

Fig. 173. Registering via KACO blueplanet web public

## 9.12 Monitoring with “blueplanet smartcloud”

**Note:** For monitoring all measurement data for PV and battery systems, you can conveniently use KACO's integrated smartcloud. The KACO server is located in Germany to securely store all sensitive customer data long-term.

↻ The <KACO Device Manager> menu has been opened and <KACO Cloud> has been selected.

1 Select <Log In / Sign Up> if you like to register in the KACO Cloud otherwise see demo to view our new datalogging.

**Note:** In the free version, the sampling rate for all measured data communicated to the cloud is 15 minutes.

**Note:** If you see potential for improvements, you can use the feedback button to describe your concern.

» Monitoring can be conveniently carried out on a larger display (tablet, monitor).

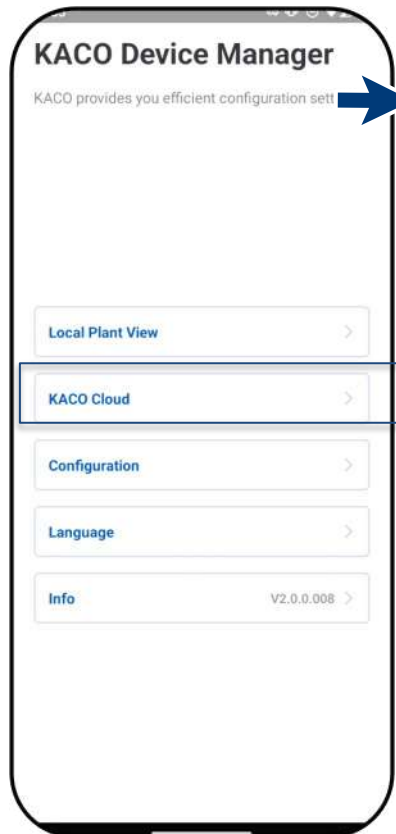

Fig. 174. Select < KACO smartcloud >

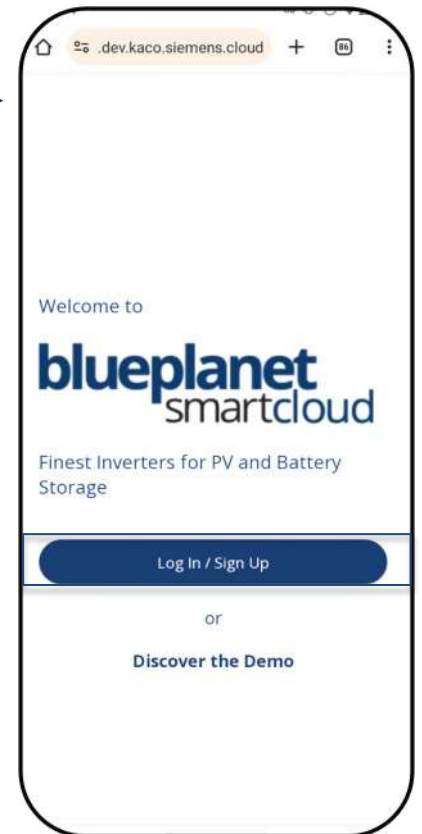

Fig. 175. Sign up for free or view the DEMO version

↻ Log In /sign up> menu has been opened and <KACO smartcloud> has been selected.

1 Enter your login details

**Note:** New registrations can be made via our customer service

**Note:** The intuitive interface graphically displays all relevant measurement data, including the degree of self-sufficiency.

**Note:** In the free version, the sampling rate for all measurement data transmitted to the cloud is 15 minutes.

**Note:** If you see potential for improvement, you can use the feedback button to describe your concerns.

» Monitoring can be conveniently carried out on a larger display (tablet, monitor).

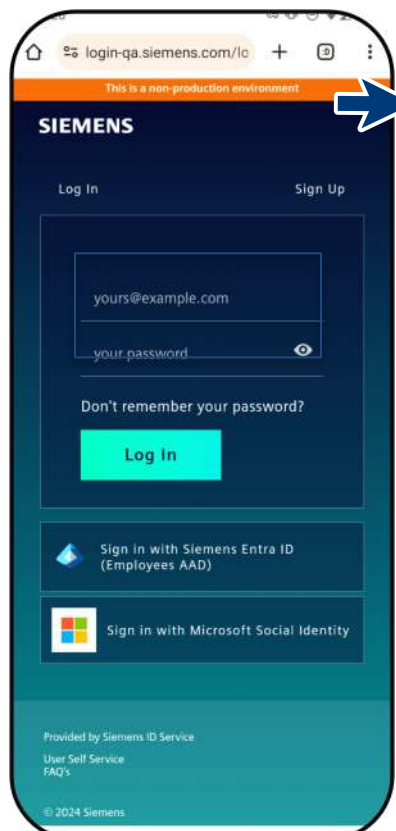

Fig. 176. Administration

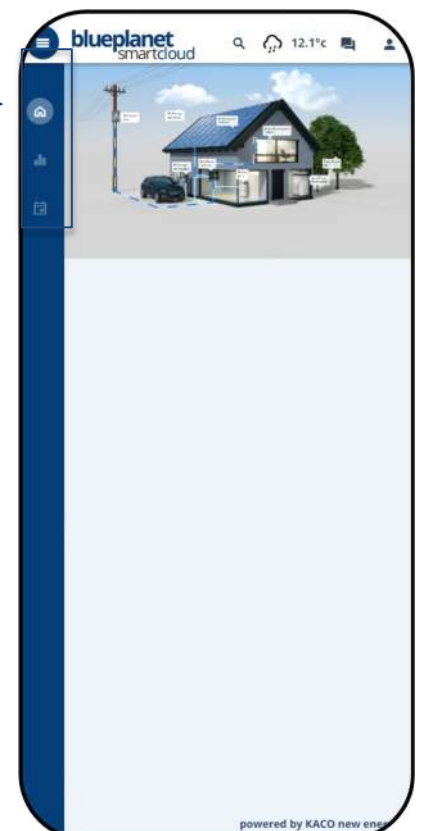

Fig. 177. Plant information

## 9.13 Information on dynamic feed-in

### 9.13.1 Control behaviour

With a system output of 7 kWp and above, a digital feed-in meter or a remote control option is still mandatory at present. Active power limitation is the simplest option here. This can be achieved for all NX3 devices via the Smart-Meter or a data logger.

With EEG 2023, the expansion of photovoltaics is to become a topic of overriding public interest. Therefore, new PV systems that are connected to the grid on or after 1 January 2023 and have a capacity of up to 25 kW will be subject to the maximum generation. This involves abolishing the 70% limit on the nominal power that may be fed into the public grid. Consequently, a solar generation meter (Smart-Meter) is no longer necessary.

### 9.13.2 Increasing the active power limitation

For the feed-in limit to be raised above 70%, a smart meter or data logger must be connected. The total consumption is communicated to the inverter/data logger by the additional Smart-Meter (3-phase) so that it can establish a new maximum feed-in power.

If the feed-in power of a PV system is compared with the consumption of a detached home, a graph such as the following example is produced.

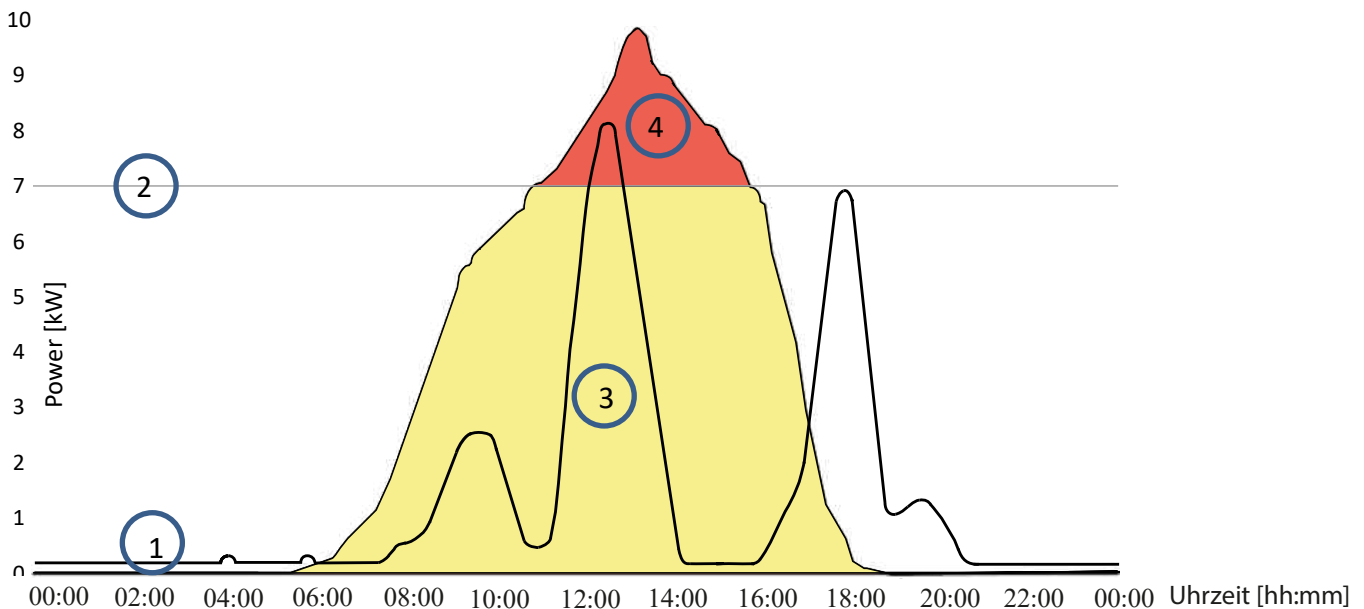

Fig. 178. Diagram comparing the energy requirement of a detached home and PV output

Legend			
1	Energy requirement of a detached home	3	70% feed-in power (yellow area)
2	70% fixed feed-in limit (grey line) – regulation command to inverter	4	Lost feed-in power (red area)

It is evident that there is a constant base load, especially at night (continuous/standby operation of consumers).

Based on this graph, we can now see that the actual self consumption values communicated should result in considerably less power being lost from the PV system.

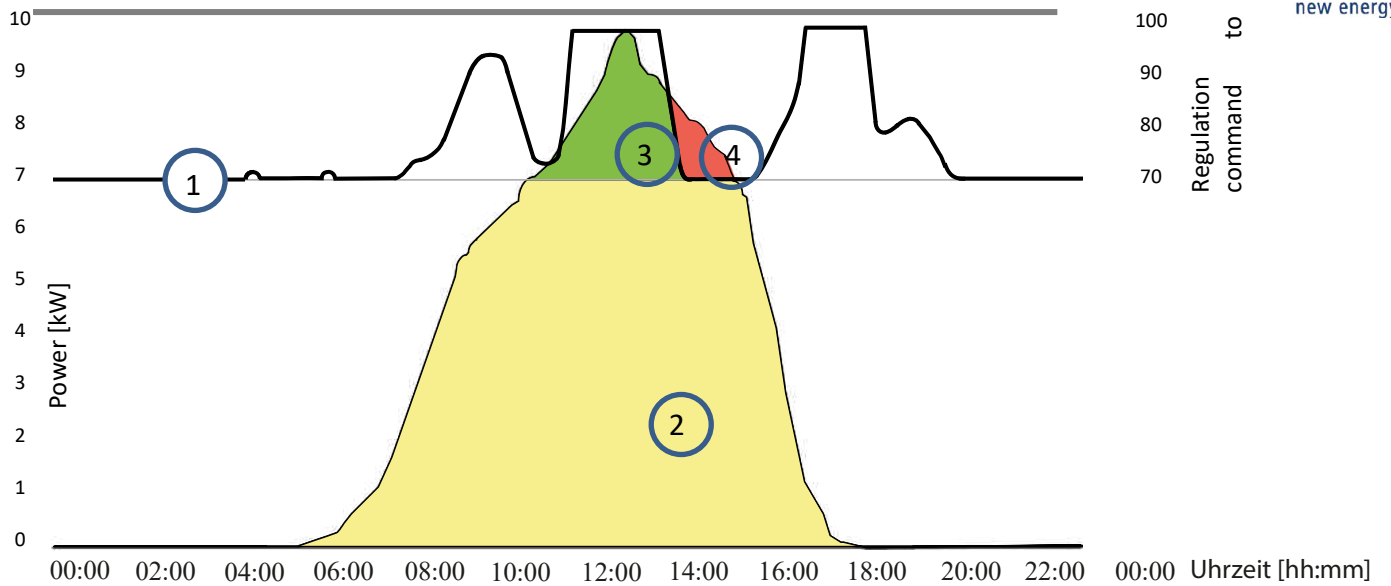

Fig. 179. Diagram of increase in self consumption

Legend			
1	Regulation command to device 70% + self consumption	3	PV power gained through self consumption
2	Energy requirement of a detached home (green area)	4	PV power lost despite self consumption

Using the feed-in meter/data logger for calculations allows more efficient use to be made of the PV system, thus providing more energy for self-consumption.

Graph Fig. 161 also shows that a red area (lost energy) is nevertheless produced because the amount of power consumed by the owner has fallen to 0 but the PV system could provide more electricity. When the self consumption falls to 0 kW, the 70% regulation function takes effect again.

The 0% feed-in regulation, on the other hand, must ensure that there is no feed into the public grid. Depending on the self consumption, the PV system output may be connected up in such a way that the user can make use of the energy generated themselves and nothing has to be purchased from the public grid.

The feed-in meter must therefore be connected to the data logger so that the logger can generate the regulation commands. If an energy meter is not connected to the data logger, the logger continuously sends a regulation command to the inverters with a 0% feed-in maximum. This means that feed-in may not take place.

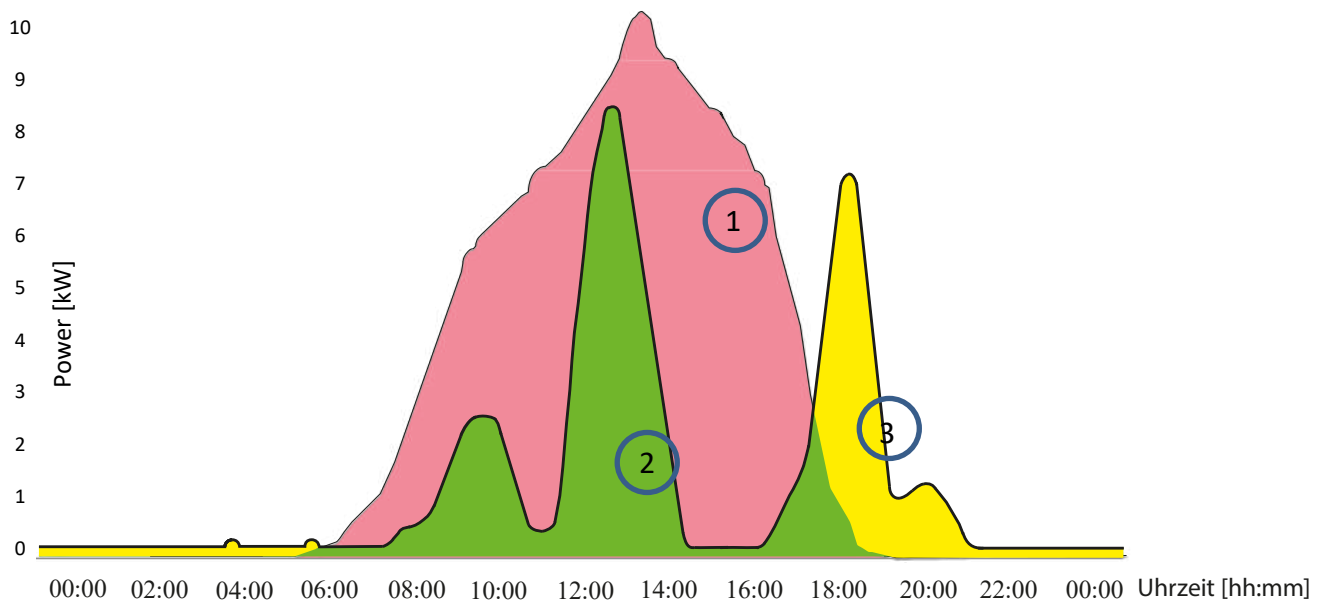

Fig. 180. Diagram of 0% regulation

Legend			
1	PV power available (red area)	3	Bought-in power (yellow area)
2	Energy requirement of a detached home (green area)		

---

By connecting up additional consumers, heating, water or energy storage systems, the self consumption and therefore the consumption of the PV current can be increased considerably.

This function can however only be used by data logger because this has an S0 output and could therefore connect up additional consumers via a relay circuit.

## 10 Maintenance and troubleshooting

### 10.1 Visual inspection

Inspect the product and cables for visible external damage and note the operating status display, where applicable. In case of damage, notify your installer. Repairs may only be carried out by an electrician.

#### **DANGER**



##### **Risk of fatal injury due to contact voltages!**

Removing the plug connections before disconnecting the device from the PV generator may lead to injuries and damage the device.

- › During installation: Electrically disconnect the DC positive and DC negative from the protective earth (PE).
- › Disconnect the device from the PV generator using the integrated DC isolator switch.
- › Remove the plug connector.

#### **DANGER**



##### **Dangerous voltage due to two operating voltages**

Coming into contact with the lines and/or terminals/busbars in the device can cause serious injury or death. The discharge time of the capacitors is up to 5 minutes.

- › Only appropriately qualified electricians authorised by the mains supply network operator are permitted to open and maintain the device.
- › Before opening the device: › Disconnect the AC and DC sides and wait at least 5 minutes.

#### **NOTE**



The housing of the device does not contain any components which can be repaired by the customer.

Do not attempt to repair faults that are not described here (in the chapter on troubleshooting and fault rectification). Contact our customer service department. Only perform the maintenance work that is described here.

The device should be checked for proper operation by a qualified electrician at regular intervals and if you experience problems, you should always contact the system manufacturer's Service department.

### 10.2 Cleaning

#### 10.2.1 Cleaning the housing

#### **DANGER**



##### **Danger of death due to penetrating fluid**

Serious injuries or death can result if moisture enters the system.

- › Only use completely dry objects to clean the device.
- › The device should only be cleaned from the outside.

#### **CAUTION**



##### **Damage to the housing parts when using cleaning agents!**

- › If the device is soiled, only clean the housing, cooling fins, housing cover and display with water and a cloth.

1 Use a vacuum cleaner or a soft brush to remove dust from the top of the device on a regular basis.

2 Remove dust from the ventilation inlets if necessary.

#### 10.2.2 Cleaning the heat sink

The housing of the device does not contain any components that can be repaired by the customer.

Do not attempt to repair faults that are not described here (in the chapter on troubleshooting and fault rectification). Contact our customer service department. Only perform the maintenance work that is described here.

The device should be checked for proper operation by a qualified electrician at regular intervals and if you experience problems, you should always contact the system manufacturer's Service department.

↻ Device switched off at integrated DC isolator switch and AC switch.

↻ Keep a suitable brush ready for cleaning.

1 Clean the free space between the cover and the heat sink using suitable brushes.

2 Clean the heat sink for the air inlet and outlet with a suitable brush.

**NOTE: Do not use any aggressive cleaning agents and ensure that no other components come into contact with fluids.**

» Cleaning completed



## NOTE

Refer to our service and guarantee conditions on our website.

- ✓ The cleaning intervals must be adapted to the environmental conditions of the installation site.
  - › In sandy environments, we recommend cleaning the heat sinks every three months.

### 10.2.3 Replacing the fan

↻ Device switched off at integrated DC isolator switch and AC switch.

↻ The fans are no longer turning.

1 Loosen the fan module screw and carefully remove the fan module downwards.  
(see Fig. 163) [ $\times$  P\_4/  $\approx$ 1.2 Nm].

2 Carefully disconnect the plug connector for the dismantled fan from inside the housing  
(see Fig. 164).

**NOTE: To clean the heat sink, only the fan module needs to be removed.**

3 Loosen the screw of each fan and insert a new fan  
(see Fig. 165) [ $\times$  P\_3/  $\approx$ 0.8 Nm] .

4 Insert the connection plug into the corresponding socket inside the housing.

5 Reinstall the fan module.

» Install the replacement fan.

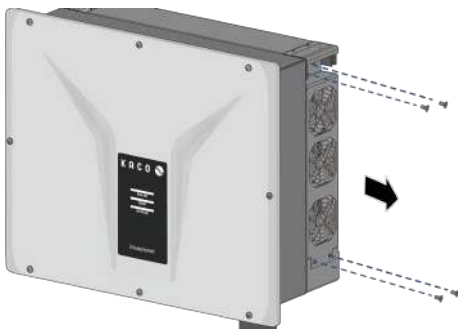

Fig. 181. Remove the fan module



Fig. 182. Unplug the connection plug

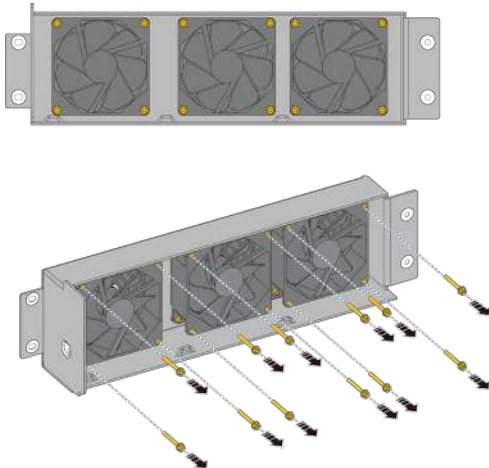

Fig. 183. Replace the fan

### 10.3 Shutting down for maintenance work / troubleshooting

 **DANGER**



**Lethal voltages are still present in the connections and cables of the device even after the device has been switched off and disconnected!**

Coming into contact with the lines and/or terminals/busbars in the device can cause serious injury or death.

Only appropriately qualified electricians authorised by the mains supply network operator are permitted to open and maintain the device.

- › Comply with all safety regulations and current technical connection specifications of the responsible power supply company.

 **NOTE:** Shutdown sequence.

1 Switch off the grid voltage by turning off the external circuit breakers.

2 Switch off the DC supply using the DC isolator switch.

**DANGER! The DC cables are still live!**

» After shutdown, wait 25 minutes before replacing the device.

### 10.4 Troubleshooting

In <Communication device properties>, a pending error is displayed under <Live values>. The error relates to the connected <Master inverter>

Error code	"N/A" is displayed here if no error has occurred.
------------	---

### 10.5 Error code

The following solutions are recommended when the error code is displayed:

No.:	Description
<b>Step</b>	<b>LED not illuminated/no power output</b>
1	Make sure that the DC isolator switch on the device is in the "1" or "ON" position.
2	Use a multimeter to check the polarity of PV+ and PV-. The red measuring probe is connected to the positive pole, the black probe to the negative pole. The value should be positive.
3	Using the multimeter, check whether the DC voltage lies within the voltage range of the inverter or not.
4	Make sure that the DC solar plug connection is not loose.
5	Use an energy meter or a clamp meter to check whether the inverter starts up. If the device starts up, the cause may be an internal short-circuit in the communication cable.

No.:	Description
<b>Step</b>	<b>AC/DC terminals melted</b>
1	It is necessary to tighten the terminals in order to establish the connection. Then, use external force to check whether the connection has loosened.
2	Take care that the cables and terminals are not subjected to excessive loads.

No.: None	Description
<b>Step</b>	<b>Ripple control receiver power de-rating is not corresponding</b>
1	Check signal wire connection is right on RJ45's PIN1~PIN5 according to user manual, if connection is right, use multimeter to measure PIN1~PIN5's on-off logic is right.
2	If this can not be solved, contact KACO service.

No.: E02-E05 E08-E10	Description
<b>Step</b>	<b>Inverter hardware may be damaged.</b>
1	Disconnect the inverter from the PV array and reconnect it after LED's turn off. If this fault is still being displayed, contact KACO service.

No.: E32-E33	Description
<b>Step</b>	<b>Grid frequency abnormal</b>
1	Check whether the grid code selection is right.
2	If this fault is caused by frequent check the grid frequency and observe how often major fluctuations occur. If this fault is caused by frequent fluctuations, try to modify the operating parameters after informing the grid operator first.

No.: E34/ E48	Description
<b>Step</b>	<b>Grid voltage abnormal</b>
1	Switch the AC isolator switch off and measure the AC voltage. The voltage between the line and the neutral conductor should be approx. 230 V.
2	If the measured voltage is abnormal, the error is caused by the grid voltage. If the measured voltage is normal, please switch the isolator switch on and continue with the next step.
3	Measure the AC voltage UL1-N, UL2-N, UL3-N using a multimeter.
4	If the measured voltage is normal, there is an error in the device. Please contact KACO service to replace the device.
5	If the measured voltage exceeds the safety requirements, please check the system voltage.

No.: E35	Description
<b>Step</b>	<b>Loss of grid supply power</b>

1	If the device error disappears and the device can be connected to the grid, please check whether an circuit breaker is installed on the AC side.
2	If the error occurs constantly, please disconnect the AC circuit breaker and measure the AC voltage. The voltage between the line and the neutral conductor should be approx. 230 V.
3	If the measured voltage is lower than 20 V, the error is caused by the system voltage. If the measured voltage is normal, please switch the circuit braker on and continue with the next step.
4	Measure the AC voltage UL1-N, UL2-N, UL3-N using a multimeter.
5	If the measured voltage is normal, there is an error in the device. Please contact customer service to replace the device. If the measured voltage exceeds the safety requirements, please check the system voltage.

No.: <b>E36</b>	Description
<b>Step</b>	<b>System leakage rms current over range</b>
1	Please check whether the fault occurs in wet and rainy weather. Also check whether the fault disappears when the weather is dry and sunny. If this is not the case, the device is not the cause of the fault.
2	Using a multimeter, check whether the voltage PV+ and PV+ to earth is normal. It should be half of PV+ and PV-. Connect the strings individually to check which string is causing the error.
3	Carry out a visual inspection of all PV strings and connections and make sure that the grounding is reliable.
4	If there is a device of the same model in operation on site, use it to replace the failed device and check whether the failure was caused by the device.

No.: <b>E37</b>	Description
<b>Step</b>	<b>PV Over Voltage</b>
1	Check the open-circuit voltages of the strings and make sure it is below the maximum DC input voltage of the inverter.
2	If the input voltage lies within the permitted range and the fault still occurs, contact KACO service.

No.: <b>E38</b>	Description
<b>Step</b>	<b>Isolation fault</b>
1	Check the PV array's insulation to ground and ensure that the insulation resistance to ground is greater than 1 MOhm. Otherwise, conduct a visual inspection of all PV cables and modules.
2	Ensure the grounding connection of the inverter is reliable.
3	If this fault occurs often, contact KACO service.

No.: <b>E40</b>	Description
<b>Step</b>	<b>Inverter overtemperature</b>
1	This error occurs when the sensor detects a high temperature in the device.

2	Check for foreign bodies in the fan or heat sink of the device which could be the cause of overtemperature in the device.
3	Please check the ambient temperature when installing the device (below 60 °C) and do not expose the device to sunlight. If the error cannot be remedied, please contact customer service to replace the device.

<b>No.: E46/ W40</b>	Description
<b>Step</b>	<b>High BUS voltage value</b>
1	If the PV voltage is too close to the bus over voltage there hold, please reconfigure the PV modules. If the PV voltage is within the MPPT voltage range, please replace the device.
2	If the error is reported for a limited period of time , the cause maybe inverter's uncontrolled. And if the device regenerates this too frequently, please contact KACO customer service.

<b>No.: E48</b>	Description
<b>Step</b>	<b>Grid voltage abnormal</b>
1	1. Switch the AC isolator switch off and measure the AC voltage. The voltage between the line and the neutral conductor should be approx. 230 V.
2	2. If the measured voltage is abnormal, the error is caused by the grid voltage. If the measured voltage is normal, please switch the isolator switch on and continue with the next step.
3	3. Measure the AC voltage UL1-N, UL2-N, UL3-N using a multimeter.
4	4. If the measured voltage is normal, there is an error in the device. Please contact KACO service to replace the device.
5	5. If the measured voltage exceeds the safety requirements, please check the system voltage.

<b>No.: E56- E58</b>	Description
<b>Step</b>	<b>GFCI 30mA/60mA/150mA level sudden change protect</b>
1	Check the PV array's insulation to ground and ensure that the insulation resistance to ground is greater than 1 MOhm. Otherwise, conduct a visual inspection of all PV cables and modules.
2	Ensure the grounding connection of the inverter is reliable.
3	If this fault occurs often, contact KACO service.

<b>No.: E65</b>	Description
<b>Step</b>	<b>Grid PE connection</b>
1	Check if the ground line is connected reliable with the inverter.
2	Ensure grid is not IT system, grid N is connected to PE.
3	If this fault occurs often, contact KACO service.

No.: E69	Description
<b>Step</b>	<b>NS protection input signal fault</b>
1	If NS protection function is not needed, this function maybe enabled by mistake, disable this by APP
2	If NS protection function is needed, check signal wire connection is right on RJ45's PIN7&PIN8, if connection is right, use multimeter measure RJ45's PIN7&PIN8 power voltage should lie in range of 8~24Vd.c..

## 10.6 Fault during connection set-up and search

**Note:** If there is a timeout or a communication failure with its WLAN network, the APP may freeze in an unwanted manner.

We recommend the following approach:

- Check the WLAN connection on the mobile end device. If the connection has been lost, reactivate it in the device settings. The window of the "KACO NX Setup" APP has to be closed completely using the overview of all opened windows, so that the "KACO NX Setup" APP can be restarted.
- If necessary, restart the search using the "Scan" button.
- If the QR code is not recognized, a manual connection to the communication device can be established in the settings of the WLAN connection on the mobile end device. SSID: Serial number communication device, password: Registration code (both printed on connect NX) see Fig. 62

**Note:** The current connection status can also be checked using the LEDs on the communication device. To do this, check the signal status by referring to Chapter 9.5 on page 35

» Faults have been corrected and the status LED on the communication device lights up continuously, signalling readiness for operation.

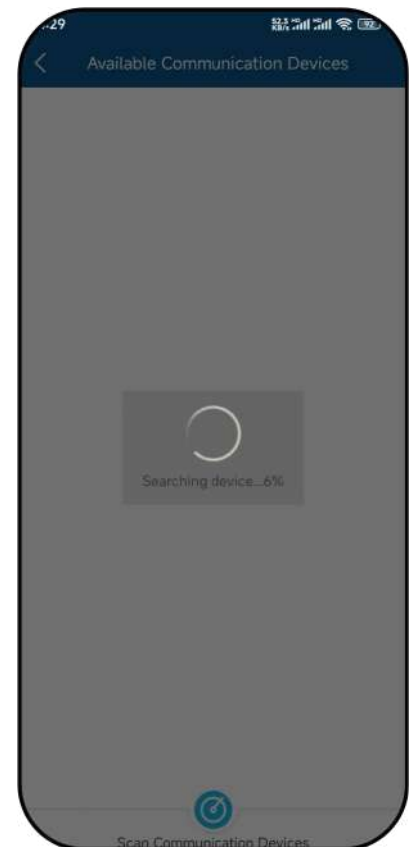

Fig. 184. Fault during connection & search

## 11 Decommissioning and dismantling

### 11.1 Switching off the device

#### DANGER

Lethal voltages are still present in the connections and cables of the device even after the device has been switched off and disconnected!

Coming into contact with the lines and/or terminals/busbars in the device can cause serious injury or death.



- › The device must be mounted in a fixed position before being connected electrically.
- › Comply with all safety regulations and current technical connection specifications of the responsible power supply company.
- › The device is only permitted to be opened or serviced by a qualified electrician.
- › Switch off the grid voltage by turning off the external circuit breakers.
- › Check that all AC and DC cables are completely free of current using a clip-on ammeter.
- › Do not touch the cables and/or terminals/busbars when switching the device on and off.
- › Keep the device closed when in operation.

#### DANGER

Risk of DC plug connectors being destroyed!



DC plug connectors can be destroyed by an arc event if disconnected while still live. It is absolutely essential that the following shutdown sequence be carried out in the correct order:

- › Use a clip-on ammeter to check that there is no current in any DC cables.

#### WARNING

Risk of burns caused by hot housing components

Housing components can become hot during operation.



- › During operation, only touch the housing cover on the device.

## 11.2 Disconnecting connections

### 11.2.1 AC connection

⌚ Ensure that the device is completely free of AC/DC voltage.

1. Turn the retaining ring to unlock it while loosening the nut with an open-end wrench. [ $\times W_{50}$  /  $\text{mm}$  10.0 Nm] [Fig. 167]

3. Using a screwdriver, press in the catch of the plug. [ $\times S_3$ ]

4. Pull the cover off the plug.

5. Loosen the screws on the contact carrier. [ $\times A_3$  /  $\text{mm}$  4.0 Nm] [Fig. 169]

6 Remove the cover and cable from the housing.

» The AC connection is disconnected.

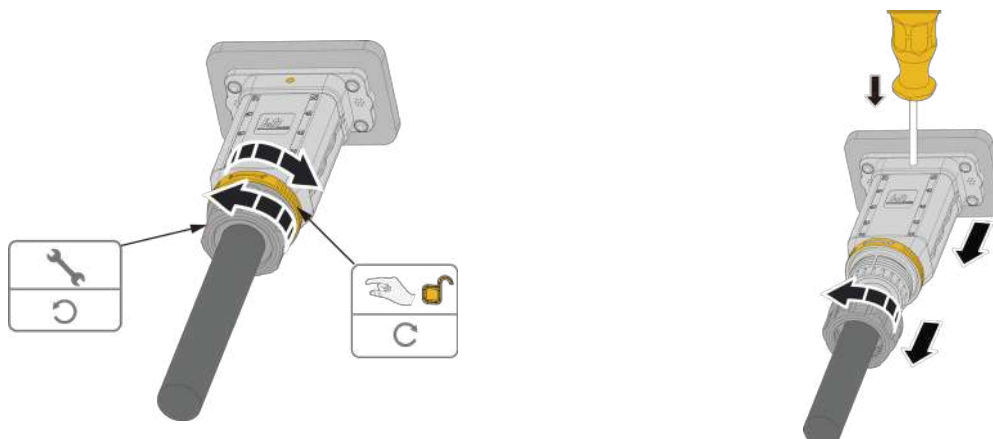

Fig. 185. Unlock the retaining ring and Loosen the nut

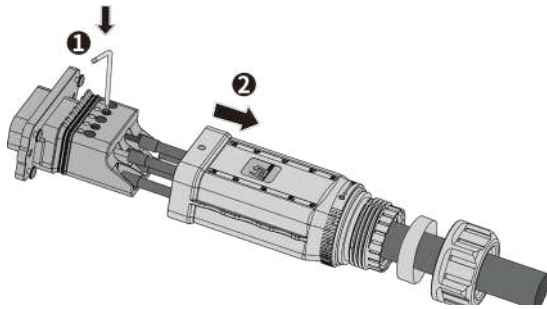

Fig. 186. Pull off the cover

Fig. 187. Detach the cable

### 11.2.2 DC connection

**⚠ DANGER**



**Destruction of the DC plug connectors !**

DC plug connectors can be destroyed by an arc event if disconnected while still live. It is absolutely essential that the following shutdown sequence be carried out in the correct order:

- › Use a clip-on ammeter to check that there is no current in any DC cables.

⌚ Ensure that the device is completely free of AC/DC voltage.

⌚ › Check that there is no current with a clip-on ammeter.

⌚ NOTE: Plug connectors may be unplugged under voltage, but never under load.

1 Use a screwdriver (blade width 3 mm) to push out the catch on the coupling.

2. Leave the screwdriver in place.

3. Disconnect the DC connector from the DC socket.

4. Remove cables and insert DC contact plug with attached protective caps. (See Fig. 171)

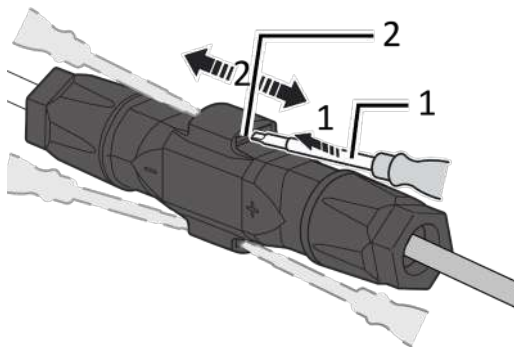

1 Screwdriver

2 Catch

Fig. 188. Unplug the plug connector

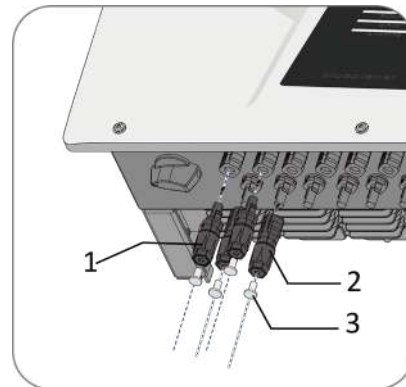

1 DC+ contact plug

2 DC- contact plug

3 Protective caps

Fig. 189. Seal DC connections

## 11.3 Uninstalling the device

### DANGER



#### Dangerous voltage due to two operating voltages

Coming into contact with the lines and/or terminals/busbars in the device can cause serious injury or death. The discharge time of the capacitors is up to 25 minutes.

» Only appropriately qualified electricians authorised by the mains supply network operator are permitted to open and maintain the device.

 Device disconnected and secured against restart.

1. Disconnect the AC connection plug from the device. AC disconnection [see Chapter 11.2.1 on page 81]
2. Detach the DC cables from the DC plug connectors and furnish with protective caps. DC disconnection [see Chapter 11.2.2 on page 82]
3. Remove the communication device.
4. If present, remove the accessory: **NX3 Smart Meter Connection Kit** in reverse order as described in Chapter 7.7.4
  - » The device has been uninstalled. Proceed with disassembly.

## 11.4 Disassembling the device

 Unit has been switched off and uninstalled.

1. Remove the screw that prevents the device from being lifted off the mount.
2. Use the lateral openings and lift the device off the mount.
  - » Device removed. Proceed with the packaging process.

## 11.5 Packaging the device

 Device has been uninstalled.

1. If possible, always pack the device in the original packaging. If this is no longer available, an alternative is to use equivalent packaging.
2. The packaging box must be fully scalable and suitable for the weight and size of the device.

## 11.6 Storing the device

### CAUTION



#### Property damage as a result of condensation

Incorrect storage can cause condensate to form in the device and impair the functionality of the device (e.g. storage outside the ambient conditions or temporary relocation from a cold to a hot environment).

- Store in accordance with the technical data > environmental data.
- Prior to installation, check the inner area for condensation and if necessary, allow it to dry sufficiently before installation.

 Device packaged.

Store the device in a dry place in accordance with the ambient temperature range specified in the environmental data.

## 12 Disposal

### CAUTION



#### Risk to the environment if disposal is not carried out in the correct manner

For the most part, both the device and the corresponding transport packaging are made from recyclable raw materials.

Unit: Defective devices and accessories must not be disposed of with household waste. Ensure that the old devices and any accessories are disposed of in a proper manner.

Packaging: Ensure that the transport packaging is disposed of properly.

## 13 Service and warranty

If you need help solving a technical problem with one of our KACO products, please contact our service hotline.

Please have the following information ready so that we can help you quickly and efficiently:

- Device name / serial number
- Date of installation / Start-up report
- Error message shown on the display / Description of the error / Did you notice anything unusual? / What has already been done to analyse the error?
- Module type and string circuit
- Consignment identification / Delivery address / Contact person (with telephone number)
- Information about the accessibility of the installation site.

You will find the following information and other information on our website [www.kaco-newenergy.com](http://www.kaco-newenergy.com).

- our current warranty conditions,
- a complaint form,
- a form for registering your device. Please register your device without delay. In this manner, you can assist us in providing you with the quickest service possible.

## 14 Appendix

### 14.1 EU Declaration of Conformity

<b>Manufacturer's name and address</b>	KACO new energy GmbH Werner-von-Siemens-Allee 1 74172 Neckarsulm, Deutschland	
<b>Product description</b>	Photovoltaic feed-in inverter	
Modules	blueplanet 25.0 NX3 M3 WM OD IIG0	[1002040]
KACO art. no.]	blueplanet 30.0 NX3 M3 WM OD IIG0	[1002041]
	blueplanet 33.0 NX3 M3 WM OD IIG0	[1002042]
Only in conjunction with:	KNE-NX3-G2-RED	[3017002]

The subject matter of the declaration described above complies with the relevant legal requirements set out in the European Union Directive of 26 February 2014 on the approximation of the laws of the Member States relating to electromagnetic compatibility (2014/30/EU), the Low Voltage Directives (2014/35/EU) and of April 16, 2014 and amendment on October 29, 2021 of the Radio Equipment Directive (2014/53/EU).

The item is compliant with the following standards:

2014/35/EU	Safety of the device
"Directive relating to electrical equipment designed for use within certain voltage limits"	EN 62109-1:2010
	EN 62109-2:2011
2014/30/EU	Interference immunity
"Directive relating to electromagnetic compatibility"	EN 61000-6-2:2005 + AC:2005
	EN IEC 61000-6-2:2019
	EN 62920:2017 Class A
	EN 62920:2017 + A11:2020 + A1:2021 Class A
	Emitted interference
	EN 61000-6-3:2007 + A1:2011 + AC:2012
	EN IEC 61000-6-3:2021
	EN 55011:2016+A1:2017 group 1, class B
	EN 55011:2016 + A11:2020 group 1, Class B
	EN 55011:2016 + A1:2017 + A11:2020 + A2:2021 group 1, Class B
	EN 62920:2017 Class B
	EN 62920:2017 + A11:2020 Class B
	Secondary effects on the grid
	EN 61000-3-12:2011
	EN 61000-3-11:2000
EN IEC 61000-3-11:2019	

In addition, the following relevant standards were applied:

2014/53/EU	Safety and Health (Article 3(1)(a))
"Radio Equipment Provision Directive"	EN IEC 62311:2020
	Electromagnetic Compatibility (Article 3(1)(b))
	EN 301 489-1 V 2.2.3
	EN 301 489-17 V 3.2.4
	Effective Use of the Frequency Spectrum Article 3(2))
	EN 300 328 V2.2.2

DR(EU) 2022/30 of 29 October 2021  
supplementing Directive 2014/53/EU

Requirements referred to in Article 3(3)(d) of the Directive 2014/53/EU  
EN 18031-1:2024

"Security of network against cybersecurity risks"

2011/65/EU

RoHS

"Directive on the restriction of the use of certain hazardous substances in electrical and electronic equipment"

EN IEC 63000:2018 (Technical documentation for the assessment of electrical and electronic equipment with regard to the restriction of hazardous substances)

The types mentioned above are therefore labelled with the CE mark.

Unauthorised modifications to the supplied devices and/or any use of the devices that is contrary to their intended use render this Declaration of Conformity null and void.

This Declaration of Conformity is issued under the sole responsibility of KACO new energy GmbH.

Neckarsulm, 29.07.2025  
KACO new energy GmbH

Neckarsulm, 29.07.2025  
KACO new energy GmbH

**Mohr**  
**Christopher**

Digitally signed by Mohr Christopher  
DN: cn=Mohr Christopher,  
o=Siemens,  
email=christopher.mohr@kaco-  
newenergy.de  
Date: 2025.07.30 07:58:46 +0200

i.V. Christopher Mohr  
Head of PM & PLM



Digitally signed by Boehler FLORIAN  
DN: cn=Boehler FLORIAN,  
o=Siemens,  
email=florian.boehler@siemens.com  
Date: 2025.07.31 06:48:31 +0200

i.V. Florian Böhler  
Head of QM



3015403-03-250731

