



MADE IN GERMANY



Installation instructions

SAX Power Home 5.8kWh
SAX Power Home Plus 7.7kWh



Table of contents

1 General information	5
1.1 Meaning of the labelling in this manual	5
2 Security	6
2.1 Intended use	6
2.2 Requirements for the installation specialist	6
2.3 General safety instructions	6
2.4 Behaviour on contact with electrolyte	6
2.5 Behaviour in case of fire	7
2.6 Extinguishing agent	7
2.7 Technical details on LFP cells	7
2.8 Disposal instructions	7
Four steps to installation	8
3 Scope of delivery	9
3.1 SAX Power Home (Plus)	10
3.2 SAX Smartmeter ADL400 Installation	10
3.3 SAX Smartmeter ADW200 Installation	10
4 Exterior view, display and connections	11
4.1 Block diagram of the storage unit	13
5 Assembly	14
5.1 Storage wall mounting	14
5.2 Mounting the storage unit on the stand	16
6 Installing the smart meter	18
6.1 Measurement concepts	18
6.2 SAX Power Smartmeter ADL400	21
6.3 Assembly	22
6.4 Communication	22
6.5 SAX Power Smartmeter ADW200	24
7 Connecting the SAX Power Home (Plus)	29
7.1 Establish power connection	29
7.2 Establishing an internet connection	29
7.3 Establishing communication connections	30
7.4 Connecting several SAX Power Home (Plus) units together	31
8 Introduction: Emergency Power, Backup Power, and Black Start	32
8.1 Differentiation between Emergency Power and Backup Power	32
8.2 Response to grid outage	32
8.3 Response upon grid restoration	32
8.4 Storage Status during Black Start Operation	33
8.5 Backup Power supply	33
8.6 General conditions for Backup Power switching	33
8.7 What type of grid network is available	33
8.8 Usable loads	33
8.9 Three-phase Backup Power supply	33
8.10 Load capacity	34
8.11 Selecting the grid changeover switch	34
8.12 Switching elements and arrangement	34
8.13 Stand-alone capability and Backup Power operation	34
9 Commissioning	39
9.1 Initial commissioning step by step	39
10 Web server and app	40
10.1 Register in the web server	40
10.2 Installing the app for the smartphone (Android)	41
10.3 Installing the app for the smartphone (Apple iOS)	42
10.4 The SAX Power Dashboard	44

Table of contents

11 Supported protocols	45
11.1 Modbus TCP control	45
11.2 Modbus TCP Basic Mode	45
11.3 Slave-ID 64: Values – SAX Power Home (Plus)	46
11.4 Modbus TCP Slave Extended Mode.	46
11.5 Slave-ID 40: Values – SAX Power Home (Plus)	47
11.6 Slave-ID 40: Values – Smartmeter	48
11.7 Slave-ID 123: Immediate Controls.	48
12 Decommissioning	49
13 Technical data	49
13.1 SAX Power Home system data	49
13.2 SAX Power Home operating data.	49
13.3 Power Home Plus system data	50
13.4 Power Home Plus operating data	50
13.5 SAX Power Smartmeter ADL400	51
13.6 SAX Power Smartmeter ADW200	51
14 Operating messages, problems and solutions.	52

This document is intended for qualified electricians. The actions described in this may only carried out by authorised electricians!

This document describes the installation of the SAX Power HOME-1-6-5-230 and HOME-2-6-4-230, as well as SAX Power HOME Plus-1-8-5-230 and HOME Plus-2-8-4-230. Please be sure to follow the instructions in this document!

Preliminary information

- Please read this document carefully before installation
- Please keep this document for your records.

This document refers to the products

„SAX Power Home“, type HOME-1-6-5-230 and HOME-2-6-4-230

„SAX Power Home Plus“, type HOME Plus-1-8-5-230 and HOME Plus-2-8-4-230

Publisher:

SAX Power GmbH

Oberer Luß 12, 89155 Erbach Germany

E-mail: info@sax-power.net, sales@sax-power.net Phone:

+49 (0) 7305 95891-1

Version 1.2
01.09.2025

1 General information

Please check the delivered device thoroughly! If there is any damage to the packaging or the device, please document this and contact SAX Power GmbH immediately!

This document serves as a manual for the SAX Power Home (type HOME-1-6-5-230 and HOME-2-6-4-230) and SAX Power Home Plus (type HOME Plus-1-8-5-230 and HOME Plus-2-8-4-230). Read this document completely before commissioning and keep it in a safe place.

In the following, the "SAX Power Home (Plus)" is also referred to as the "storage unit". To simplify the presentation of the SAX Power Home and SAX Power Home Plus systems, two values are for different properties in this document. The larger value is assigned to the SAX Power Home Plus.

Meaning of the labelling in this manual



Danger! Failure to observe the safety instructions may result in death or serious injury.



Caution! Failure to observe the safety instructions may result in injury or damage to property.



Helpful information.

2. Security

The SAX Power Home (Plus) stores electrical energy.

Any use of the appliance other than that described in these instructions is considered improper use. SAX Power GmbH accepts no liability for any damage resulting from failure to follow the instructions or from disregarding safety and warning notices.

Please observe the following safety instructions carefully:

2.1 General safety requirements

1. Installation:

The installation may only be carried out by a certified electrician. The storage unit may only be put into operation after it has been fully installed.

2. Intended use:

Only use the storage unit in a suitable, permanently installed location (see chapter 2.3). Any modifications or openings to the device are not permitted and lead to the cancellation of guarantee and warranty claims.

3. Hazardous substances:

The use of lithium iron phosphate (LFP) cells minimises the risk of fire. However, irritating substances can be released in the event of a fire.

2.2 Requirements for the installation specialist

The storage unit may only be operated by a trained electrician in accordance with the standard DIN VDE 1000- 10 VDE 1000-10:2021-06 "Requirements for persons working in the field of electrical engineering".

2.3 Intended use

The storage unit may only be installed in suitable indoor locations. The following conditions must be observed:

- Environment: Protected from water and foreign bodies (<2 mm diameter).
- Temperatures:
Operation: +5°C to +35°C.
Storage/transport: - 10°C to +40°C.
- Humidity: Max. 80% relative humidity.
- No direct sunlight.
- Distances: 150mm distance in all directions (see chapter 5).
- Hazardous areas: Do not install in potentially explosive atmospheres or in areas with corrosive gases.

Please note the following information:

- Do not open the housing - danger to life!
- Only switch off the storage unit when it is at least 50% charged for up to 6 months (avoid deep discharge).
- Only operate in perfect condition.
- No independent repairs or modifications.
- Do not block the ventilation openings.
- Never bypass or modify the safety devices.
- Do not change the connections for power and data. Faults according to chapter "Operating messages, problems and solutions".
- Always lift the storage unit with at least two people.

2.4 Behaviour on contact with electrolyte

- Skin contact: Immediately wash the affected area thoroughly with water and remove contaminated clothing.
- Eye contact: Rinse eyes immediately with plenty of water.
- Inhalation of vapours: Leave the area and breathe in fresh air.
- Medical help: Consult a doctor immediately if you experience any symptoms.

2.5 Behaviour in case of fire

LFP cells are considered to be very safe. However, mechanical damage or environmental fires can cause the battery cells to ignite. Should a fire occur, please react as follows:

- 1. Safety distance:**
Keep your distance, as toxic vapours are produced and explosions may occur.
- 2. Evacuation:**
Leave the room and close the door if possible to prevent the spread of toxic vapours.
- 3. Emergency call:**
Call the fire brigade and inform them about the battery fire.
- 4. Power cut-off:**
Switch off the storage unit at the main switch. Also switch off the grid fuse in the building.



If it is not possible to switch off, use extinguishing agents to contain the fire.

2.6 Extinguishing agent

- Use CO₂ or ABC powder for battery fires.
- Maintain a safe distance.
- Water can be used to cool neighbouring cells.

2.7 Technical details on LFP-cells

The storage consists of 120 LFP cells, organised in 24 strings with 5 cells each in series (16V DC). Operation takes place at 230V AC grid voltage.

2.8 Disposal instructions

Old or damaged batteries are classified as hazardous waste and must not be disposed of with normal household waste. Please observe the following instructions:

- 1. Proper disposal:**
Have the batteries disposed of by an authorised disposal company.

Observe the applicable regulations in your region for the disposal of lithium-ion batteries.
- 2. Contact points:**
Contact your dealer, manufacturer or a certified collection centre for batteries to obtain further information on disposal.
- 3. Environmental awareness:**
Improper disposal can cause environmental and health risks. Ensure that the batteries are disposed of in an environmentally friendly manner.

Four steps to installation

1.

Installing the storage unit
Page 14

2.

Installation of the smart-meter
Page 18

3.

Connecting the storage unit
Page 29

4.

Commissioning the storage unit
Page 39

3 Scope of delivery

3.1 SAX Power Home (Plus)

in the scope of delivery:

1. SAX Power Home 5.8 kWh.
2. Wall bracket with 2 screws for positioning the storage unit.
3. MSTB 2.5/4-ST terminal block.
4. 2 Wieland plugs.
5. Quick installation guide.
6. Handles.

Smartmeter if necessary (depending on configuration)



5

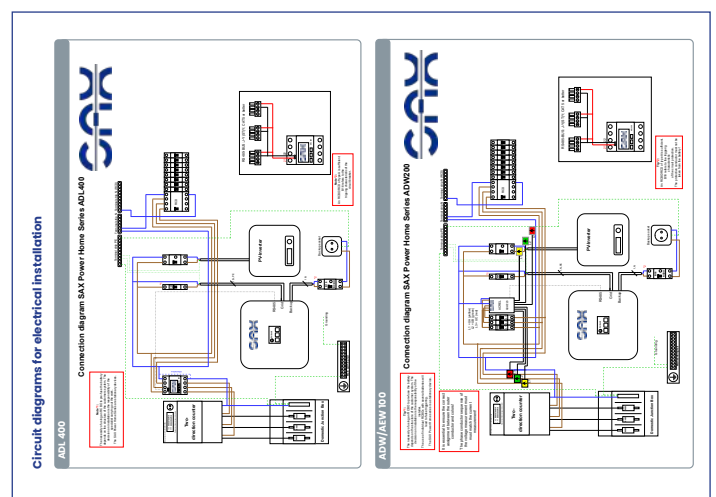
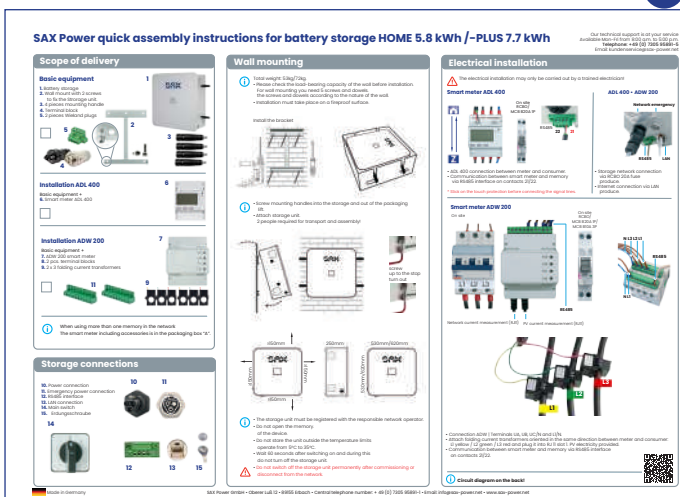

Fig. 1

3.2 SAX Power Smartmeter ADL400 installation



in the scope of delivery:

1. 1 Smartmeter ADL400.

Fig. 2 Smartmeter from the front (ADL400)

3.3 SAX Power Smartmeter ADW200 installation

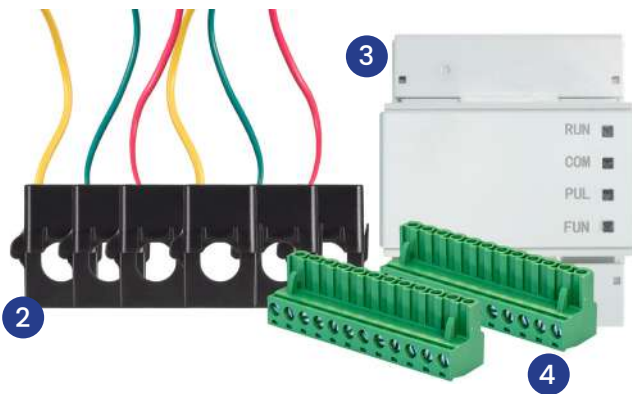

in the scope of delivery:

2. 2 x 3 hinged current transformers.
3. 1 Smartmeter ADW200.
4. 2 MSTB 2.5/12-ST terminal blocks.

Fig. 3 Scope of delivery ADW200



The cables required for professional connection of the storage unit are not included in the scope of delivery. You can order the necessary cables from your SAX Power specialist partner. A 3P B10 miniature circuit breaker is also required for the ADW200.

The pipe cross-sections required for connecting the storage unit must be determined by the specialist installing the system.

If more than one storage unit is used in the network, the Smartmeter including accessories in packaging box "A".

4 Exterior view, display and connections

The display is an energy-saving e-paper display; when switched off, the last status remains permanently visible on the display. The charge status, the IP address of the storage unit, the grid power and the charging and discharging power of the storage unit can be read on the display.

In conjunction with the ADW200, it is also possible to display the power of the PV inverter. This is realised via an AC-side measurement using additional current transformers.



Fig. 4 Side view right



Fig. 5 Front view of the storage unit with e-paper display



Fig. 6 Side view left



Fig. 7 Bottom view of the storage unit



Fig. 8 Rear

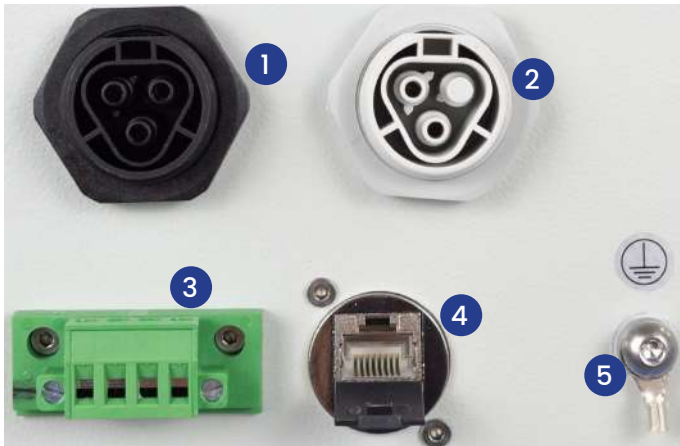

Fig. 9 Storage unit from below (connections)



Fig. 10 Main switch



Fig. 11 Type plate

Connections of the storage unit:

1. Grid connection.
2. Back up power connection.
3. RS485 interface and digital input for switch-off by the network operator (optional).
4. LAN connection (RJ45).
5. Connection point for additional grounding.
6. Main switch.
7. Type plate DE.

4.1 Block diagram of the storage unit

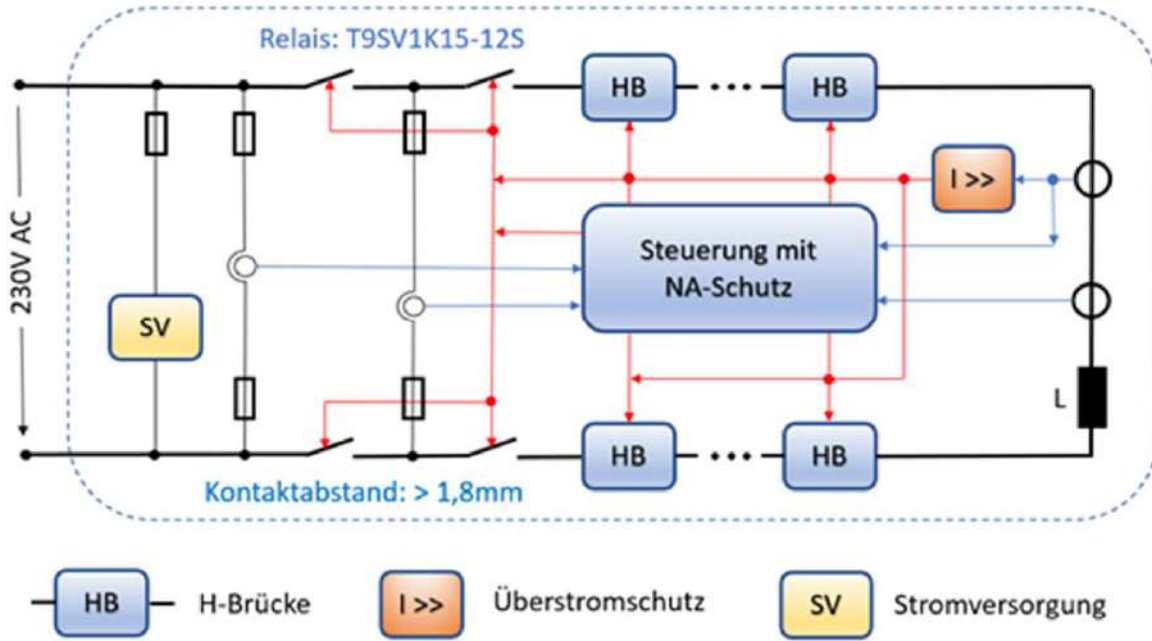

Fig. 12 Internal wiring of the storage unit

5 Assembly

The SAX Power Home (Plus) can be mounted on the wall if it has the necessary load-bearing capacity. SAX Power offers stand base as an alternative to wall mounting. At 5.8kWh this offers space for 3 storage units, at 7.7kWh for 2 storage units.

5.1 Storage unit Wall mounting

i Total weight: 55kg / 72kg

Please check the load-bearing capacity of the wall before mounting. You will need 5 screws and wall plugs for wall mounting (not included). The screws and wall plugs must be selected according to the material and condition of the wall.

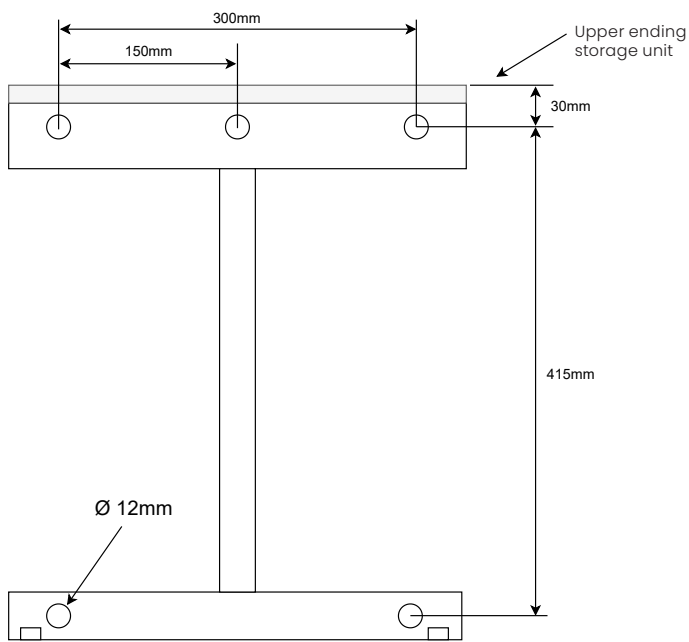

Fig. 13.1 Hole spacing Sax Power Home 5.8kWh

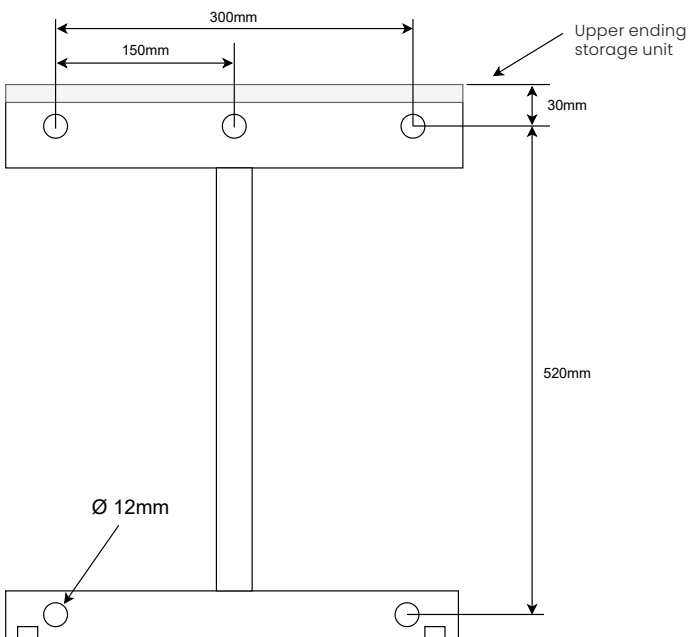

Fig. 13.2 Hole spacing Sax Power Home Plus 7.7kWh

1. Align the wall bracket with a spirit level and observe the mounting distances (Fig. 13.3).

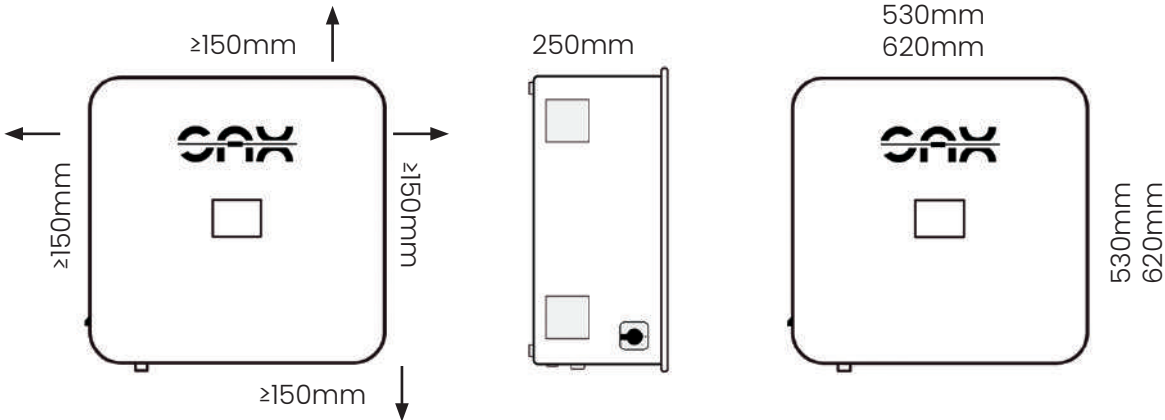

Fig. 13.3 Distance specifications and storage dimensions

2. Drill holes into the wall.

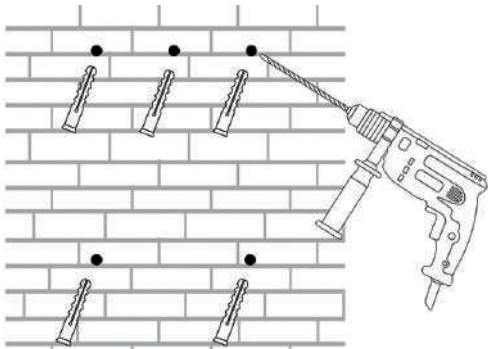

Fig. 14 Wall hole pattern

3. Fix the wall bracket with suitable plugs and screws.

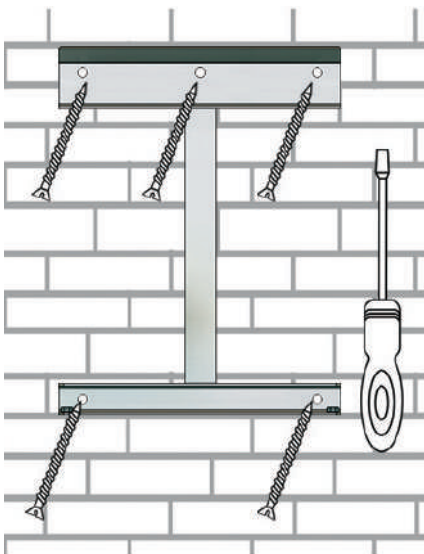

Fig. 16 Fixing the wall bracket

4. Ensure that the screws are fully screwed in.

5. Hang the storage unit on the wall bracket.

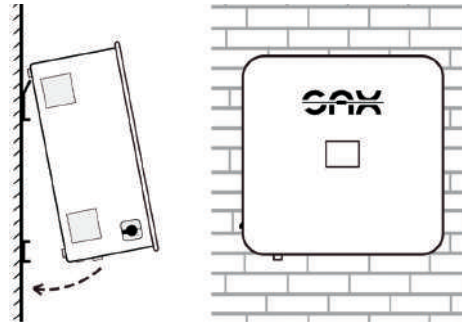

Fig. 15 Mounting procedure

6. Unscrew the screw until the storage unit is braced with the bracket (Fig. 17 & 18).



Fig. 17 Bracing the storage unit



Fig. 18 Fully braced storage unit

Note:



The storage unit is tensioned by unscrewing the screw.

5.2 Mount the storage unit on the stand

1. Fit the tubes to the base plate.
2. Fit the cross struts for the storage bracket to the tubes of the stand.
3. Screw the tubes to the wall (prevents the stand from tipping).
4. Attach the safety screws to the underside of the bracket and screw in completely.
5. Hang the storage unit on the stand base with two people.
6. Unscrew the screw until the storage unit is braced with the bracket. (see chapter 5.1).



Fig. 19 Three 5.8kWh storage units mounted on the stand



Fig. 20 Empty stand (5.8kWh)

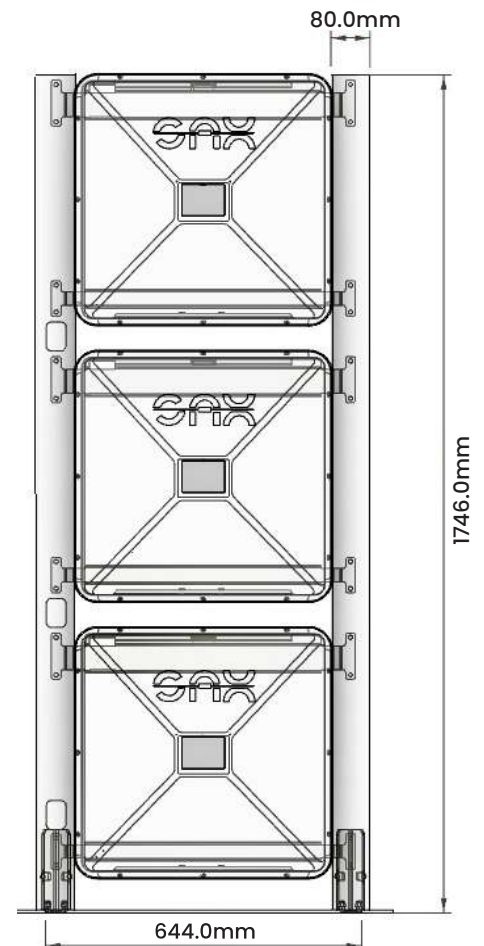

Fig. 21 Dimensions of base (5.8kWh)

1. Cross struts
2. Safety screws
3. Tubes
4. Cable outlet: Cables can be routed here in the inside of the stand and can be guided cleanly to the floor
5. Base plate



Fig. 22 Dimensioning of base plate



Caution: Note the alignment of the base plate. Align the drill holes in the base plate with the rear of the storage unit.

The following applies to the SAX Power Home Plus:

1. Fit the tubes to the base plate.
2. Fit the cross struts for the storage bracket to the tubes of the stand.
3. Screw the tubes to the wall (prevents the stand from tipping).
4. Attach the safety screws to the underside of the bracket and screw in completely.
5. Hang the storage unit on the stand with two people.
6. Unscrew the screw until the storage unit is braced with the bracket. (see chapter 5.1).



Fig. 23 Two 7.7kWh storage units mounted on the stand



Fig. 24 Empty base (7.7kWh)

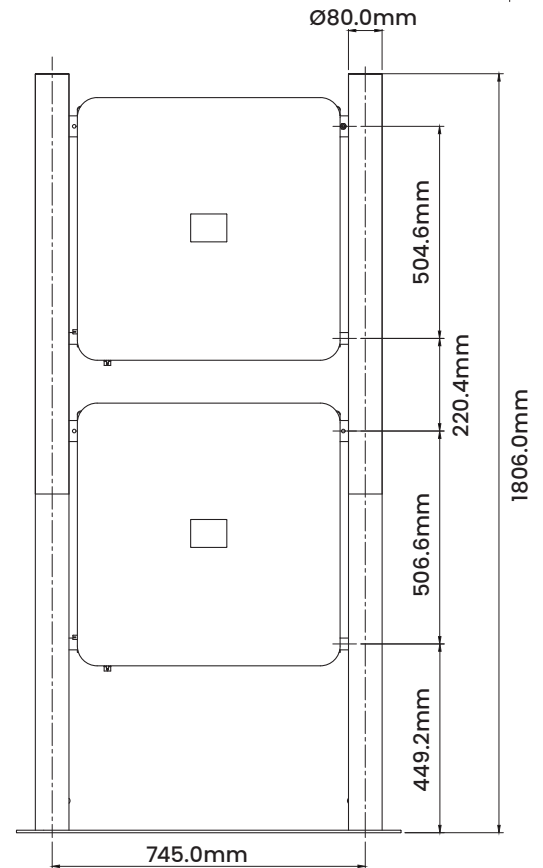

Fig. 25 Dimensions of the base (7.7kWh)

1. Cross struts
2. Safety screws
3. Tubes
4. Cable outlet at the rear: Cables can be neatly routed to the floor inside the stand.
5. Base plate

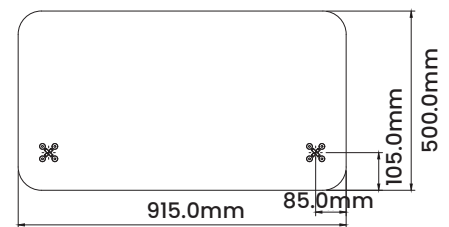

Fig. 26 Dimensioning of base plate



Caution: Note the alignment of the base plate. Align the drill holes in the base plate with the rear of the storage unit.

6 Installation of the smart meter

6.1 Measurement concepts

All prescribed safety regulations, VDE regulations and the valid technical connection conditions (TAB) of the responsible distribution network operator must be observed.

Depending on the desired measuring concept, the smart meter is installed behind the corresponding meter in the customer network. The storage unit is controlled as standard so that the power is removed at this point.

Possible metering concepts are shown below:

Example 1: Measurement concept 4 (one generation system)

SAX Power Home storage system connection diagram

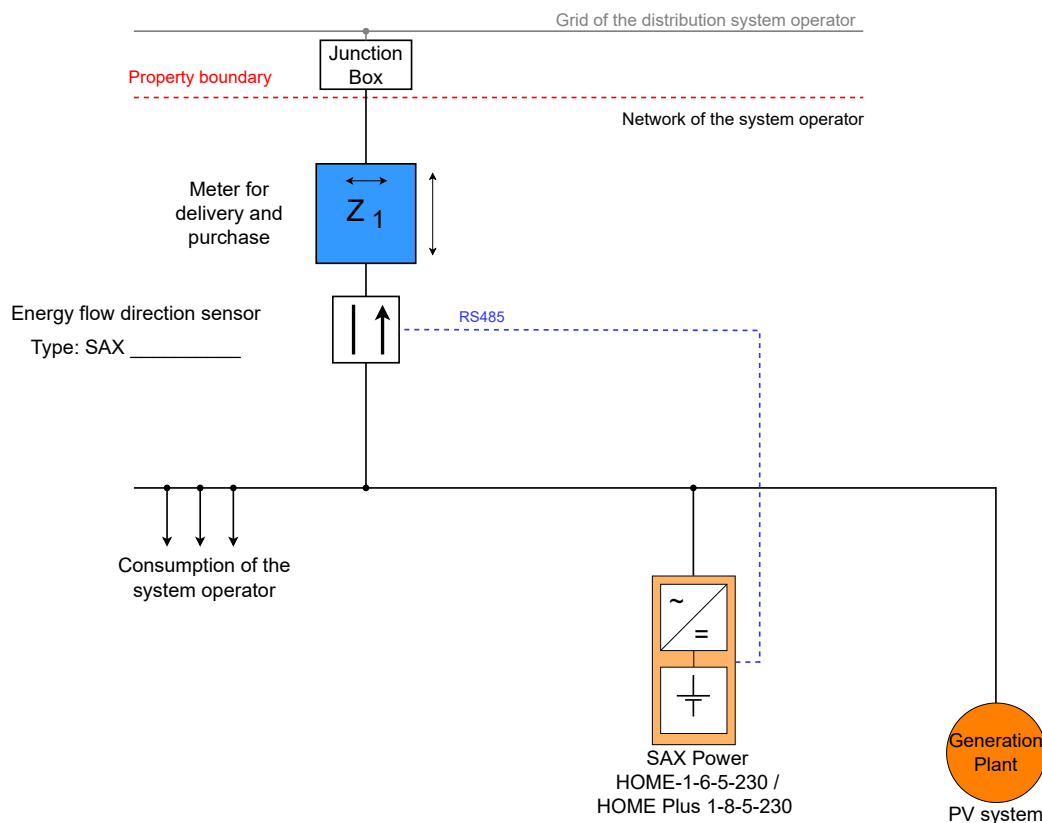

Fig. 27 Measurement concept (one generation system)

Example 2: Measurement concept 4 (two storage units)

SAX Power Home storage system connection diagram

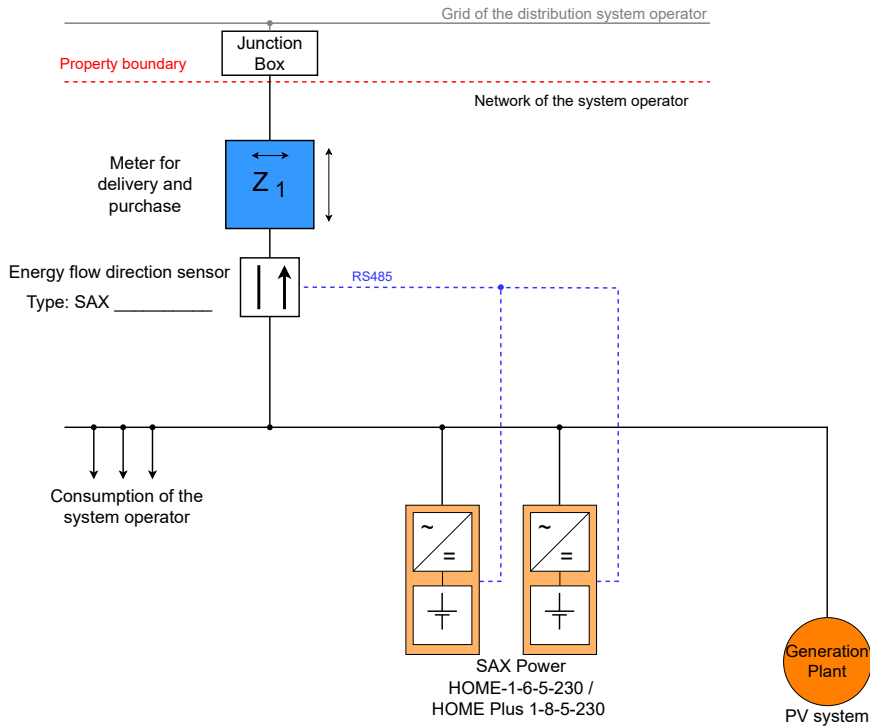

Fig. 28 Metering concept (two storage units, one generation system)

Example 3: Measurement concept 4 (three storage units)

SAX Power Home storage system connection diagram

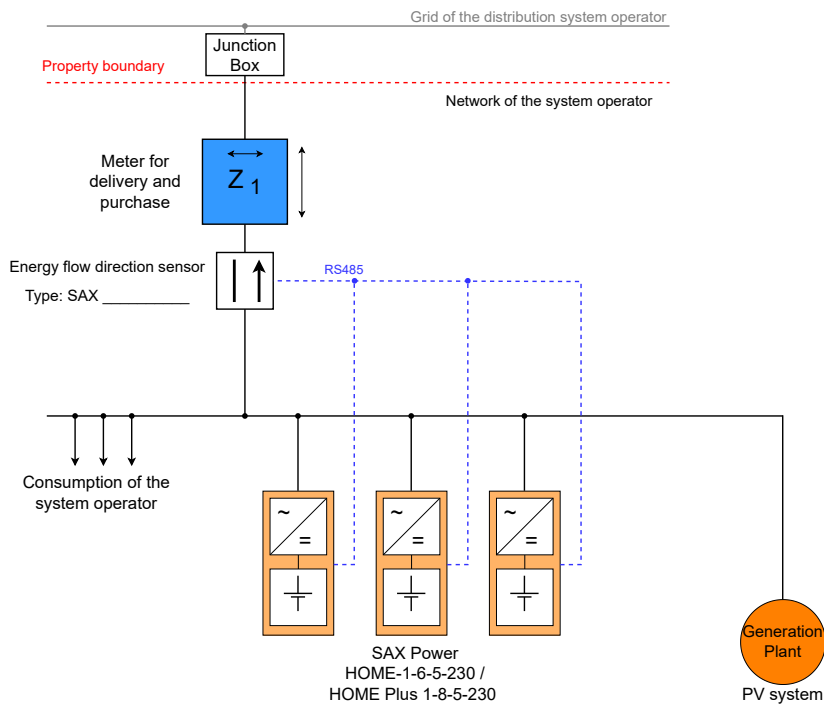

Fig. 29 Measurement concept (three storage tanks)

Example 4: Measurement concept (two generation plants with different energy sources)

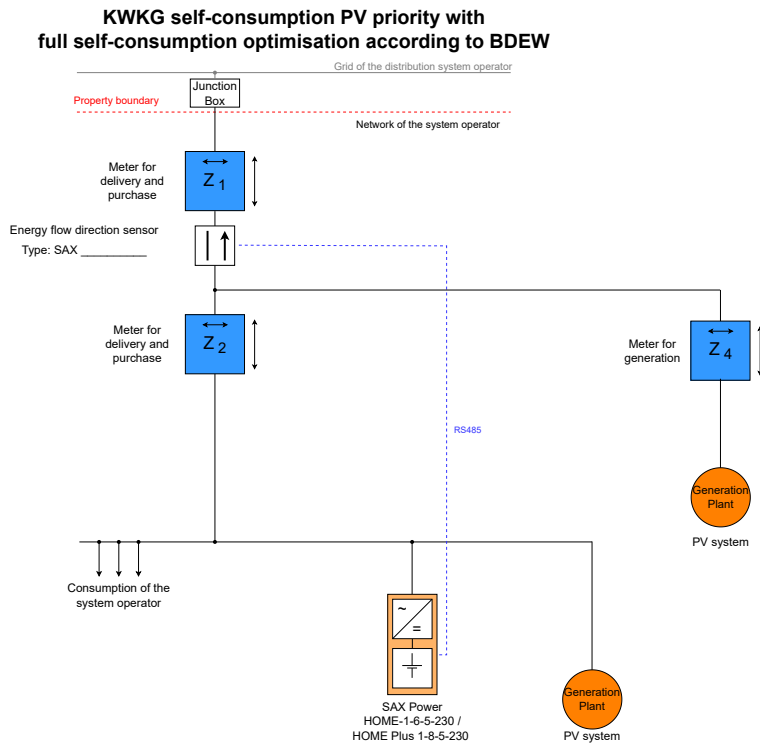

Fig. 30 Metering concept (two generation systems)

Example 5: Measurement concept (two generation plants with different energy sources)

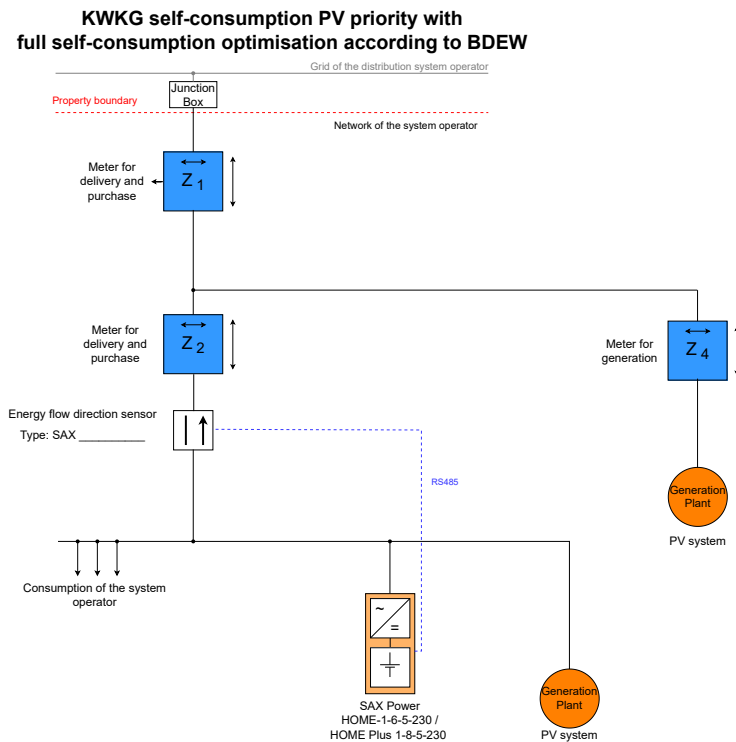

Fig. 31 Metering concept (two generation systems)

6.2 SAX Power Smartmeter ADL400

The ADL400 is a smart meter (energy flow direction sensor) for three-phase power measurement (direct measuring).

Communication takes place by means of an RS485 connection via Modbus RTU (9600 8N1).

The ADL400 is used in the standard installation:



Fig. 32 ADL400: Front view



Fig. 33 ADL400: Bottom view



Fig. 34 ADL400: Top view

6.3 Assembly

Attach the smart meter to the top-hat rail (TH 35mm, 4TE) in the distribution board

1. Connect the connections L1, L2, L3 and N.
2. Tighten all screws.

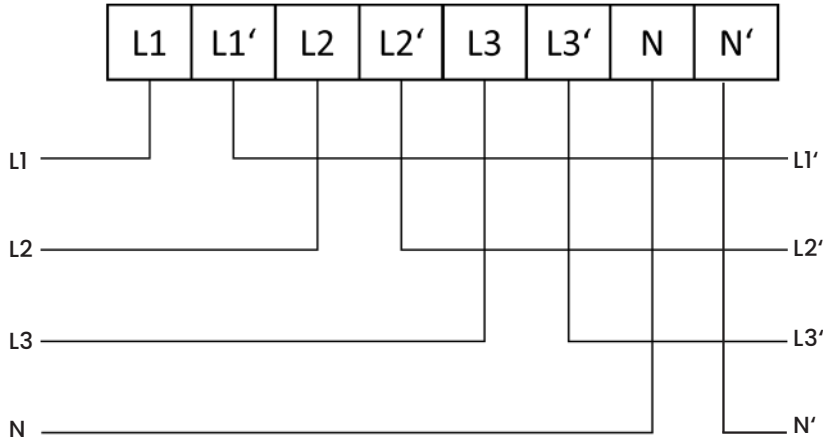

Fig. 35 Direct measurement ADL400 connection diagram

6.4 Communication



The storage system carries out a smart meter test during initial commissioning. The sign of the measurement is determined by feeding it into the grid. The installation direction of the smart meter is therefore not fixed, but may be changed after the test. The device cannot be changed after initial commissioning.



Connections 21 and 22 are used for the RS485 connection. Ensure the correct polarity when connecting the cable to the storage unit!

To prevent accidental contact with grid voltage when connecting the signal cables to the ADL400, you will find a sticker enclosed with the ADL400. This serves as contact protection and must be stuck over the screw holes of the grid connection terminals before connecting the signal cables.



Fig. 36 ADL400 correctly connected

Note:



Correct and professional installation is the responsibility of the specialist carrying out the work. SAX Power GmbH accepts no responsibility for damage caused by improper installation.

When using a bus cable with braided shield, use a shrink sleeve or similar means to ensure that the shield cannot come into contact with live conductors.

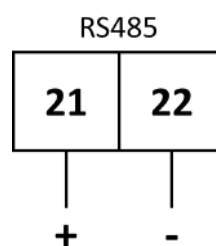

Fig. 37 Correct RS485 polarity

ADL400 - Circuit diagram for the electrical installation

Connection diagram SAX Power Home Series ADL400

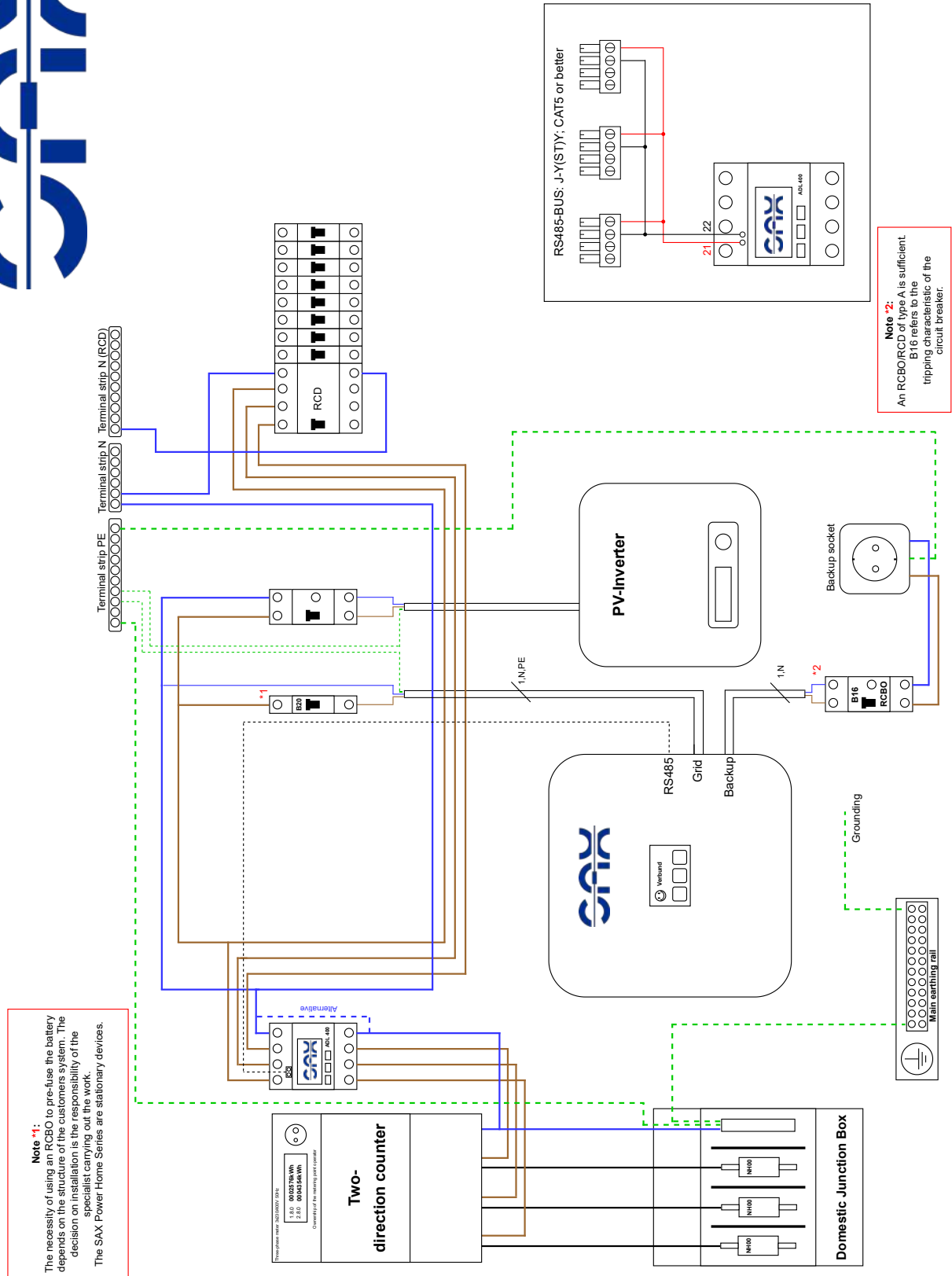

Fig. 38 Connection diagram with ADL400 (standard installation)

6.5 SAX Power Smartmeter ADW200

The ADW200 is a smart meter for three-phase power measurement.

The current measurement is carried out with hinged current transformers up to 100A. (Maximum cable cross-section: 70mm². Inner diameter: 16mm)



Fig. 39 ADW200: Front view

- RUN: Supply voltage is present. If RUN is not flashing slowly: Check SM connection (L,N).
- COM: Flashes when the storage unit is requesting data. If Com is not flashing: Check RS-485 connection!
- PUL: Not used.
- FUN: Not used.



Abb. 40 ADW200: Bottom view

- CH1: Current transformer grid measurement.
- CH2: Current transformer measurement of the generation system.
- CH3: Not used.
- CH4: Not used.

POWER/RS485: LORA module connection.



Attention:
No network connection.
The network hardware and storage unit can be damaged when connected!

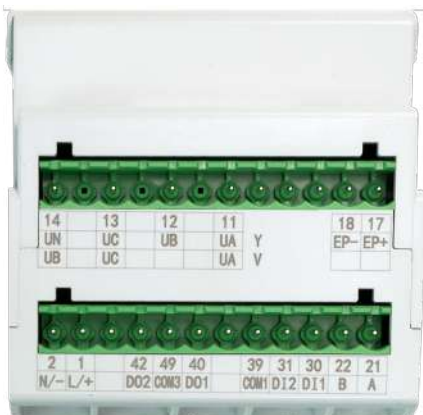

Fig. 41 ADW200: Top view

- 14: N (measurement)
- 13: L3 (measurement)
- 12: L2 (measurement)
- 11: L1 (measurement)
- 2: N (supply)
- 1: L (supply)
- 22: RS485 (-)
- 21: RS485 (+)

Assembly

Attach the ADW200 smart meter to the top-hat rail (DIN 35 mm).



Fig. 42 ADW200 mounted on top-hat rail (DIN 35 mm)

Connections

1. Connect the cables both to terminals 11-14 for voltage measurement and to terminals 1-2 for the auxiliary supply. (Maximum cross-section: 2.5mm²)

Note:

Please note that one terminal between terminals 11-14 is not assigned.

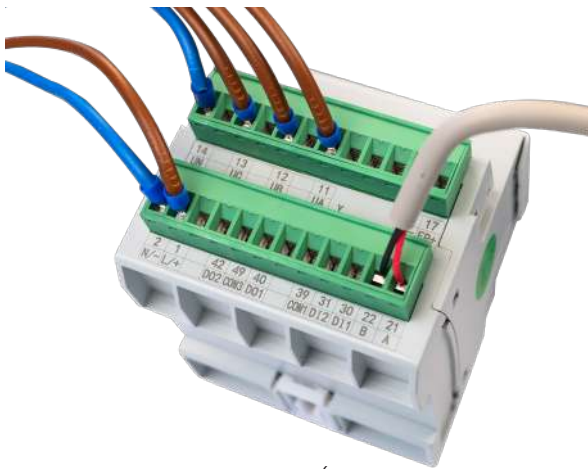

Fig. 43 Connection overview (RS485, voltage measurement, power supply) ADW200

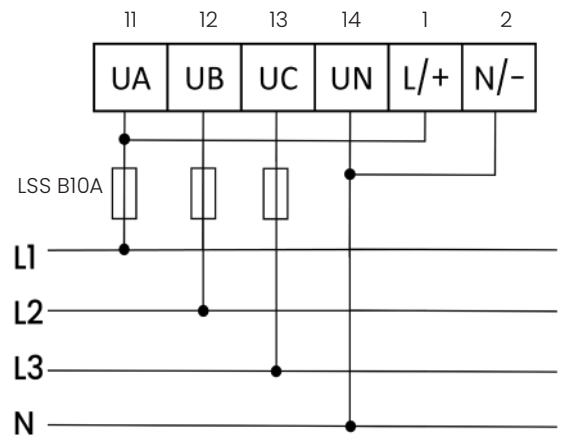

Fig. 44 Connection diagram for voltage measurement and power supply

1.1 If required: Extension of the current transformers

The connection cable of the current transformer for measurement on the grid or at the generation system can be extended under certain conditions.

For short extensions < 5 metres:

- RJ12 modular cable extension type RJ12 6P6C.

Extensions > 5 metres up to a maximum of 100 metres:

- CAT7 S/FTP installation cable.
- Extension is possible using a soldered connection, LSA insulation displacement connectors or spring clips (Wago terminals).
- The assignment of the transducers and the correct polarity must be observed exactly.
- A separate twisted pair of wires must be used for each transducer.
- The pin assignment of the RJ12 connector of the transducers can be found in the figure below
- If a UAE socket is used, it must not be assigned according to TIA-568A/B. The wire pairs must be laid side by side as shown in Fig. 45.



The storage system carries out a smart meter test when it is first put into operation. During this test, the sign of the measurement is determined by feeding it into the grid. The installation direction of the current transformers is therefore not fixed. However, the direction of the arrow must be the same on all transformers. However, it must not be changed after initial commissioning.

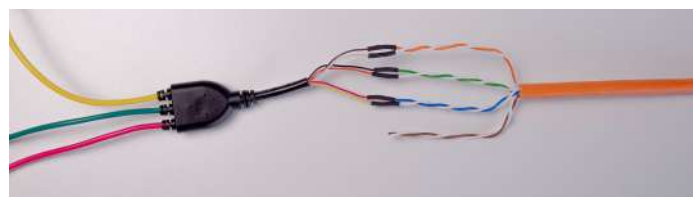

Fig. 45 Extension of the measuring line 5 to a maximum of 100 metres

Assignment of ADW200 folding transformer

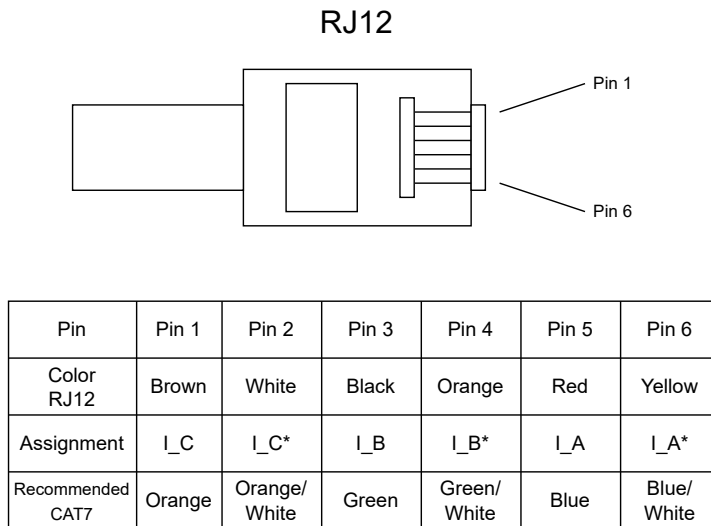

Fig. 46 Folding transformer assignment (ADW200)

- Connect the hinged current transformer to phase L1 (yellow), L2 (green) and L3 (red). Establish connection to CHI. Ensure correct colour assignment and arrow direction!

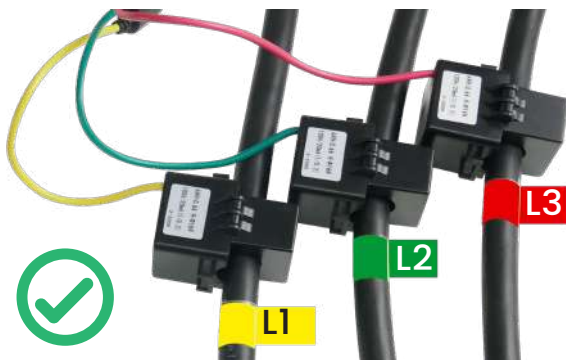

Fig. 47 Same orientation of all transducers

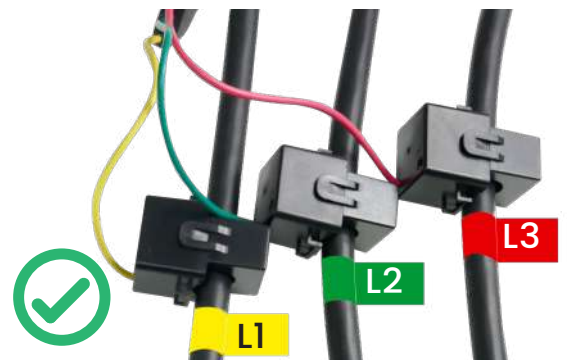

Fig. 48 Same orientation of all transducers

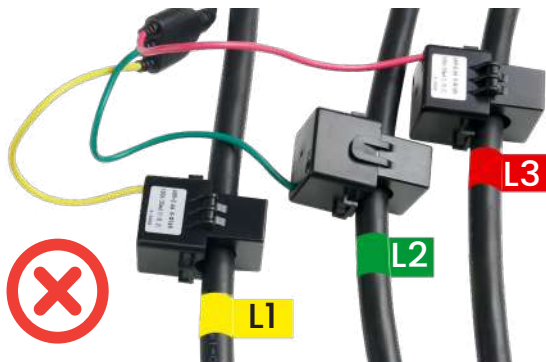

Fig. 49 Incorrect orientation of transducer L2 transformer

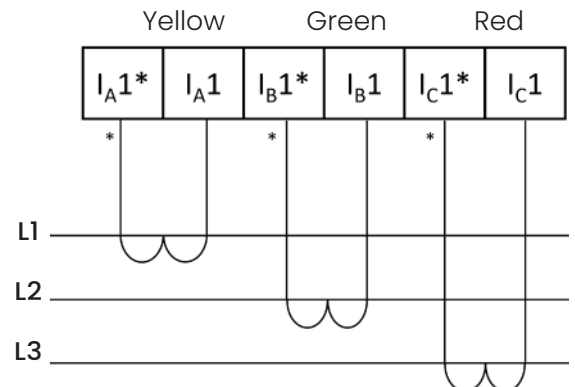

Fig. 50 Connection diagram for hinged current transformer

3. Install a hinged current transformer for each phase of the generation system (correct colour assignment! Phase L1 (yellow), L2 (green) or L3 (red)). Plug the signal cable of the transformer into CH2.

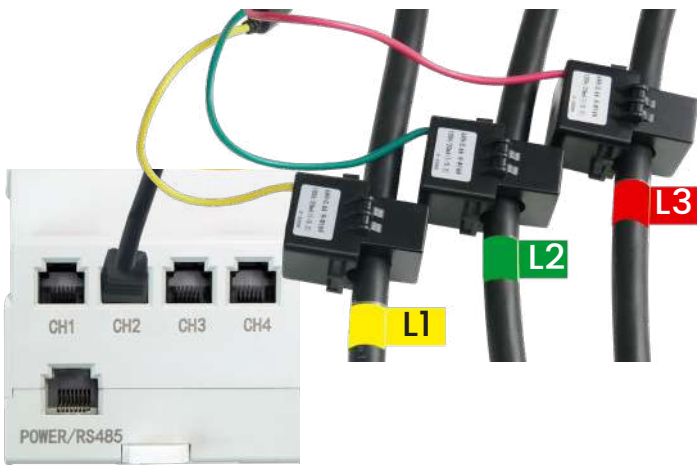

Fig. 51 Connection of the hinged current transformers to the AC side of the generating system

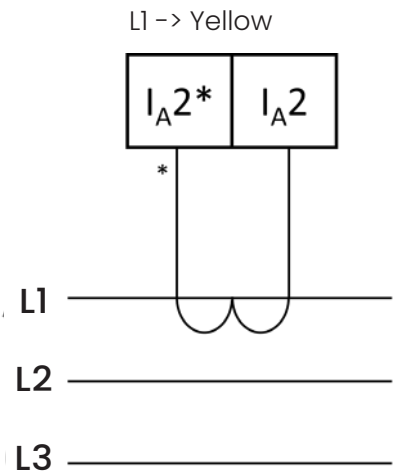

Fig. 52 Measurement diagram of a hinged current transformer in the case of a single-phase inverter on L1



ATTENTION:

Observe the colour assignment! Ensure consistent connection! (Colour assignment as under point 2. for the second phase)

Communication

Cable connection to the SAX Power storage unit: Connections 21 and 22 are used for the RS485 connection. (See Fig. 37)

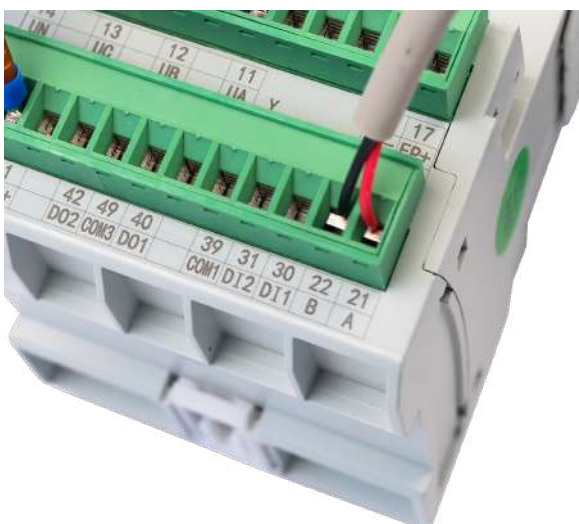

Fig. 53 Pin assignment RS485 on the ADW200 smart meter

Connection diagram SAX Power Home Series ADW200



ADW200 - Circuit diagram for the electrical installation

Tip #1:
The necessity of using an RCBO to pre-fuse the battery depends on the structure of the customer system. The decision on installation is the responsibility of the installer.
The use of individual RCBOs with several batteries will lead to false triggering.
The SAX Power Home series is a stationary device.

It is essential to ensure the correct assignment between the outer conductor and colors!
The phase conductor sequence of the voltage measurement must match the current measurement!

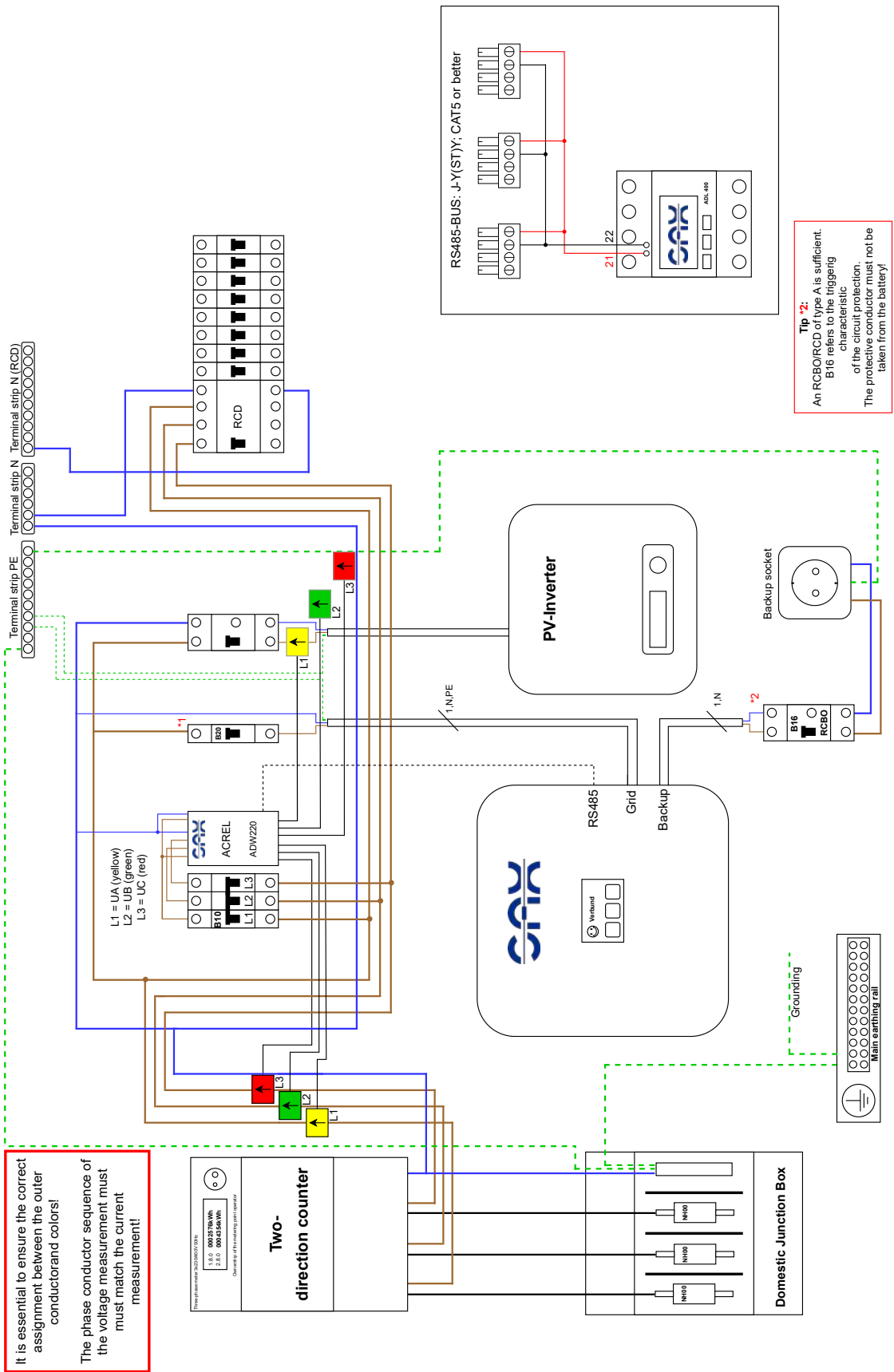

Tip #2:
An RCBO/RCD of type A is sufficient. B16 refers to the triggering characteristic of the circuit protection. The protective conductor must not be taken from the battery!

Fig. 54 Connection diagram with ADW200

7 Connect SAX Power Home (Plus)

7.1 Establish power connection

The connection from the house connection to the SAX Power Home (Plus) must be designed for a current load of 20A. This generally requires a 3 x 2.5mm² cable with a Wieland connection (for the grid connection) and, if necessary, a further 3 x 2.5mm² cable with a Wieland connection

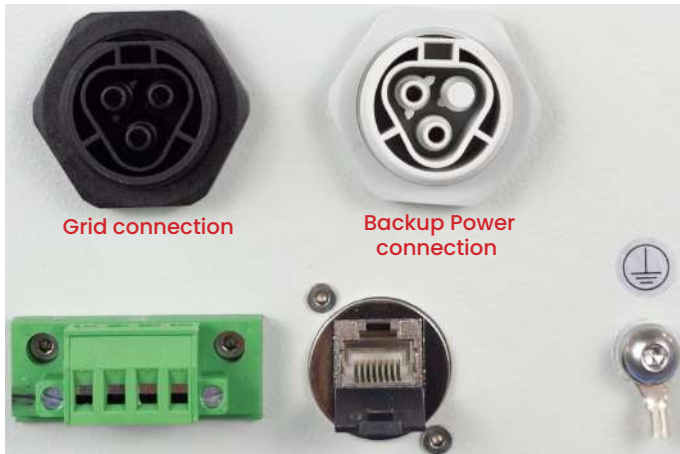

Fig. 55 Connections

for the Backup Power connection (the cables are not included in the scope of delivery). Recommended cable type: YSLY-JZ 3G2.5 or H07RN-F 3G2.5 or H05VV-F 3G2.5.

Use of NYM-J not recommended.

1. Establish grid connection to L1, N and PE in the distributor.
2. Execution and logging of all necessary measurements in accordance with VDE 0100 at the grid connection.
3. Connect the grid cable to the grid connection on the SAX Power Home (Plus).
4. If a second or third SAX Power Home (Plus) storage unit is to be connected, connect the second storage unit to L2, N and PE; connect the third to L3, N and PE.

7.2 Establish Internet connection



Each storage unit must be connected to the Internet via the LAN connection

1. Connect the LAN cable to a free port on a router.
2. Connect the LAN cable to the storage unit.

By connecting the storage unit to the Internet you benefit from the following advantages

- Operating data can be displayed via the web portal.
- Remote diagnosis by SAX Power Support is possible.
- Important software updates can be carried out.
- The SAX Power manufacturer's warranty requires a connection to the Internet.

Note:



- The storage unit works as a DHCP client and obtains its IP address automatically. This requires an active DHCP server in the network (usually the WLAN router). Manual address assignment is possible via a DHCP server. Reservation in the router.
- The Internet connection must be established via a cable connection. If WLAN repeaters, powerline adapters ("DLAN"), or similar devices are used, any resulting connection problems are not covered by SAX-Power Support.

Ports 80 and 5700 are used for communication.

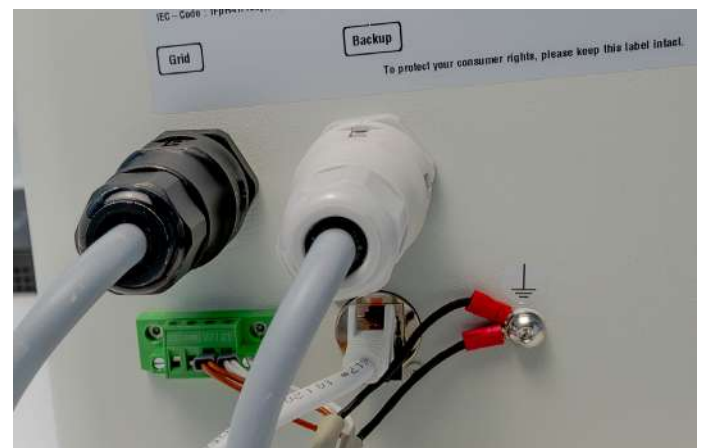

Fig. 56 Wired storage unit

7.3 Establish communication connections

1. Two cores of a communication cable (e.g. J-Y(ST)Y 2 x 2 x 0.8; EIB Y-(ST)Y 2 x 2x 0.8; LiYCY; CAT5) are required. For flexible cables Use tourniquets.
2. Connect output 21 of the smart meter to terminal 21 on the storage unit, connect output 22 of the smart meter to terminal 22 on the storage unit.
3. Tighten the screws on both terminal blocks. (Smartmeter and storage unit)

If several storage units are used, they must be connected as follows (Fig. 57):

RS485 connection via J-Y(ST)Y, CAT5 or better

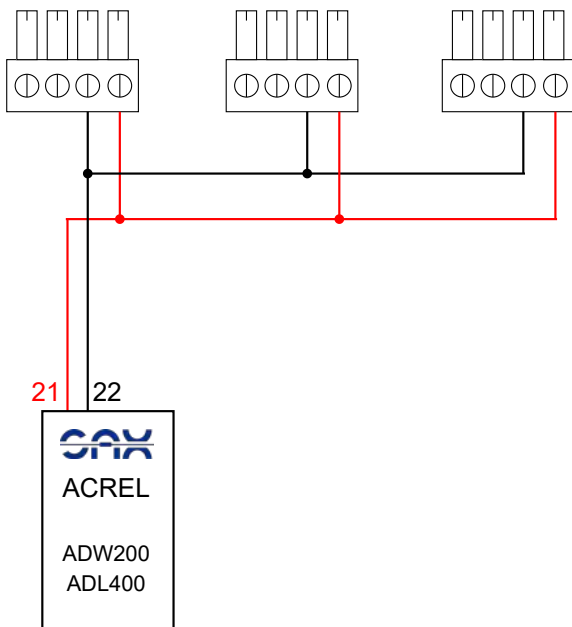

Fig. 57 RS485 parallel connection for a multi-phase system

Note:



When using a communication cable with more than 2 cores, it is important that a double core of the cable is used. (See Fig. 58)

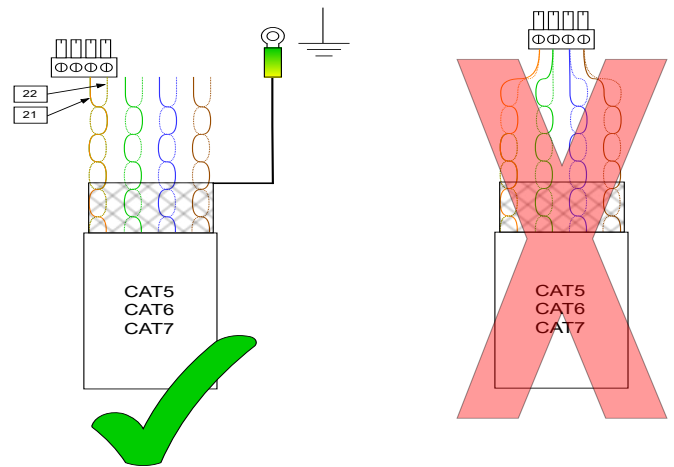

Fig. 58 Communication line assignment

Note:



For cables with braided shielding, the shielding must be connected to the connection point for additional earthing on the storage unit housing.

7.4 Connect several SAX Power Home (Plus) with each other

The SAX Power Home (Plus) is modularly expandable to up to 3 devices. Each storage unit is connected single-phase (see "7.1 Establishing the power connection").

Several storage units are connected as follows:



Fig. 59 Three SAX Power Home (Plus) in a network

1. Establish an RS485 connection between the storage units. To do this, connect terminals 21 and 22 of the storage units in parallel via terminals.
2. Establish an RS485 connection between the storage units. To do this, connect terminals 21 and 22 of the storage units in parallel via terminals.
3. Each storage unit must be connected to the Internet via the LAN connection. See chapter "Establishing an Internet connection".



Fig. 60 RS485 connection for master and 1st slave storage unit in a network of 3 SAX Power Home (Plus)

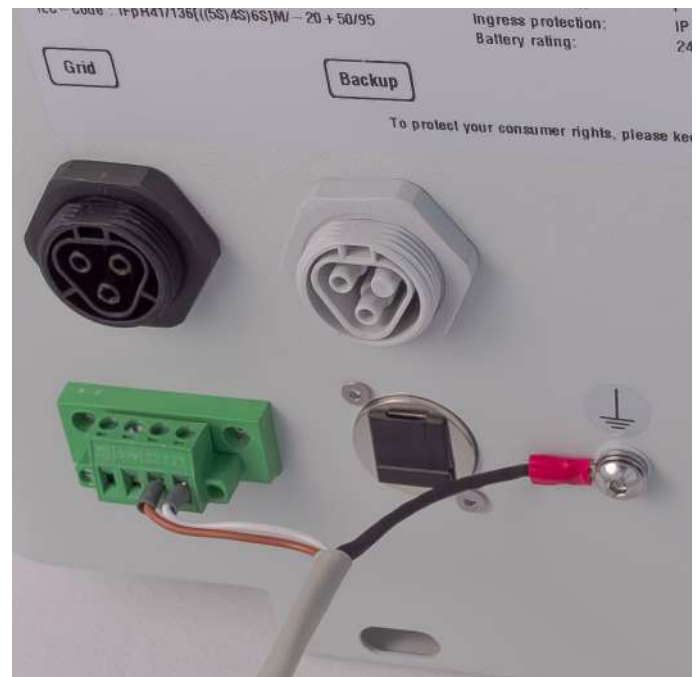

Fig. 61 RS485 connection for individual storage unit or last storage unit in the network

8 Introduction: Emergency Power, Backup Power, and Black Start

With the Emergency Power function enabled, the storage system always keeps a capacity reserve of 9% available for emergency operation. This reserve can also be used without the Black Start option in the event of a grid failure. If this remaining capacity is exhausted, or if the storage system is shut down due to an overload or short-circuit event at the emergency output, it can only be restarted once the grid power is available again or if the Black Start option is installed.

With the help of the Black Start function, however, a completely shut down system can be restarted, ensuring the supply of the house even during extended grid outages.

8.1 Differentiation between Emergency Power and Backup Power

The storage systems keep a capacity reserve of 9%. In the event of a grid outage, the connected Emergency Power socket will continue to be supplied. If a transfer switch is installed, the entire house can continue to be supplied.

Emergency Power:

Variant 1: Black Start option not installed.

The storage supplies the loads until its capacity is exhausted. In the event of an overload, the storage cannot be restarted.

Variant 2: Black Start option installed.

The storage supplies the loads until its capacity is exhausted. In the event of an overload, the storage can be restarted using the Black Start button.

Recharging the storage via the generation unit is not possible in either case!

Backup Power:

Variant 1: Black Start option not installed.

The storage first supplies the loads directly from the generation unit. If its output is not sufficient, the storage supplies the loads until its capacity is exhausted. The storage is then shut down and cannot be restarted—even if the generation unit could provide power again. In the event of an overload, the storage also cannot be restarted.

Variant 2: Black Start option installed.

The storage first supplies the loads directly from the generation unit. If its output is not sufficient, the storage supplies the loads until its capacity is exhausted. The storage is then shut down, but as soon as the generation unit provides enough power again to supply the connected loads, the storage can be restarted using the Black Start button. For this purpose, the residual capacity in the storage is used, which—even at a state of charge of 0%—is still sufficient to start and synchronize the inverter of the generation unit.

In the event of a shutdown caused by an overload, the storage can likewise be restarted using the Black Start button.

Recharging the storage via the generation unit is possible in both cases, provided that all other requirements are met!

8.2 Response to grid outage

If the grid fails, the storage system continues to provide voltage at the emergency power output. If a manual transfer switch is installed, it must now be set to the “Emergency” position. If an automatic transfer switch is installed, it will automatically switch to the “Emergency” position after the preset waiting time has elapsed.

8.3 Response upon grid restoration

When the grid voltage becomes available again, this is indicated with a manual transfer switch by the repeated switching on and off of the storage system’s Emergency Power supply. This behavior is due to the relay test required by standards when the grid returns. The manual emergency transfer switch can then be set back to the “Grid” position.

When using an automatic transfer switch, the system switches back to the “Grid” position automatically—after the grid returns and the preset waiting time has elapsed—without sporadic interruptions. On most models, including the Chint G NXZB-63H, this waiting period is indicated by a flashing red LED.

8.4 Operation of the storage system when using the Black Start function

To restart the shut-down storage system using the Black Start function, the following steps must be carried out:

- Grid voltage is not available: the Black Start button is not illuminated.
- Set the main switch of the storage system to the "On" position.
- Press and hold the Black Start button until it lights up. Depending on the previous shutdown reason, this may take up to 30 seconds.
- The storage system now provides voltage at the emergency output.
- If multiple storage systems are installed: repeat for each system.

The storage systems will display the error message "Island" or "U<<". This indicates the failed grid supply and is part of normal operating behavior.

8.5 Backup Power supply

The SAX Power Home (Plus) provides an IT network Backup Power mode. There is no connection between the neutral conductor and the protective conductor.

A protective contact socket fitted to the back up power outlet must be pre-fused with a circuit breaker. If the storage unit feeds its full power into the household grid, this current is added to the pre-fuse of the storage unit. This means that a current of up to 40A can be drawn without the correct back-up fuse. [This is an acute fire hazard!](#)

8.6 General conditions for backup power switchover

In order to realise a Backup Power switchover in a house, the following framework conditions must first be checked:

8.7 What type of grid network is available?

If the house is supplied by a TT or TN-S system, the switchover can be realised without any problems. In the case of a TN-C system, it is essential to ensure that:

- The PEN conductor is only split once and is not merged again.
- No sub-distribution boards in the house are supplied in the TN-C system.
- The PEN conductor is not switched under any circumstances.

8.8 Usable Loads

This is a Backup Power supply. Therefore, a supply for heavy loads is not always guaranteed!

Examples:

- Powerful induction hobs.
- Air compressors.
- Power tools with high starting current.
- Refrigeration machines of higher capacity (heat pumps, cold rooms).

Single-phase Backup Power supply

If a single-phase Backup Power supply is installed, no three-phase consumers may be operated in the Backup Power supply. In order to avoid overloading the neutral conductor when operating consumers with a 5-pole supply line (e.g. hob, cooker), a circuit breaker with monitoring of the neutral conductor must be used. A 4-pole miniature circuit breaker is not necessarily sufficient for this! The correct designation must be observed.

A 3P+N type miniature circuit breaker only provides complete protection for the neutral conductor's grid disconnection, but does not monitor the neutral conductor.

When using 2 SAX Power Home (Plus) storage units, 2 phases are available in the same way, but 2 phases must still be bridged together. Two SAX Power Home (Plus) storage units in combination then provide two phases, each shifted by 120°.

8.9 Three-phase Backup Power supply

If there are three-phase consumers in the house that are also to be supplied by the Backup Power supply, this can only be realised with 3 SAX Power Home (Plus) storage units. This provides a system with 230V/400V, phase shift 120°, clockwise rotating field.

8.10 Load capacity

A system consisting of SAX Power home storage units can be loaded in Backup Power mode as follows:

- 1 storage unit: 4.6kVA 1-phase (230V, 20A).
- 2 storage units: 9.2kVA 2-phase (230V/400V, 20A), storage unit B phase-shifted by 120° compared to storage unit A.
- 3 Storage units: 13.8kVA 3-phase (230V/400V, 20A), phase shift 120°, clockwise rotating field with phase sequence A-B-C.

8.11 Selection of the grid changeover switch

A suitable changeover switch must be selected to realise the grid changeover. It is important to ensure that the changeover switch fulfils the following properties:

- 4-pole switching.
- Leading closing and lagging disconnection of the neutral conductor.
- Sufficient current carrying capacity in accordance with the distributor's backup fuse (40A or 63A).
- Mechanical interlock between grid and backup position (no simple contactor changeover!).

If manual switching is sufficient, a simple changeover switch with top-hat rail mounting can be installed directly in the distribution board.

Examples:

- Sontheimer ULO63/4T/NS/Z101/F976.
- ABB OT63F4C.

Automatic switching can be realised with an ATS (Automatic Transfer Switch). However, it should be noted that the installation costs are considerably higher, as the automatic transfer switches have significantly larger dimensions and cannot usually be installed in the distribution board. An external switch cabinet with mounting plate may be necessary here. The supply and return cables on the grid side must then be routed into the switch cabinet with a sufficient cross-section (min. 10 mm²). Furthermore, in order to maintain layman's serviceability, sufficient protection against accidental contact must be provided in the switch cabinet.

8.12 Switching elements and arrangement

The arrangement of the switching elements can be found in the circuit diagrams provided. When using multiple SAX Power Home (Plus) storage units, a multi-pole circuit breaker must be used.

The back-up fuse of a multi-phase system with individual RCBOs for each storage unit will lead to false tripping and damage.

If the customer's system requires the use of an RCD upstream of the storage units, selectivity must be maintained. Failure to do so may result in false tripping and/or damage to property.

When using an ADW smart meter, please note that the smart meter's power supply must not be supplied by the Backup Power. The tap for the measurement must therefore be made before the switchover.

8.13 Stand-alone capability and Backup Power Operation

If a PV inverter or other generation system is used in stand-alone operation, additional points must be observed in order to avoid material damage to end consumers, inverters or storage systems.

In order to avoid overproduction in the Backup Power grid, the storage system dynamically regulates the output frequency via the P(f) characteristic of the inverter. The inverter uses this frequency control to reduce the feed-in power and limit the maximum charging power.

The following points must be observed:

- If you have a storage unit with a serial number 1002300xxx, the hardware version and thus the compatibility must be requested from customer service.
- Analogue to the consumers, a 3-phase inverter requires the use of 3 storage units.
- The load must be as symmetrical as possible.
- The generation capacity in the Backup Power grid must be limited to a maximum of 5kVA per phase.



Attention:

A prerequisite for stand-alone operation is the availability of a P(f) characteristic curve in the configured grid connection standard of the inverter. This is available in the standards, among others:

AR-N-4105
TOR generator type A
NIN 2020 & CH standard VSE

Inverters configured in accordance with VDE 0126-1-1- 2006 or earlier are not suitable for stand-alone operation.

Connection diagram for SAX Power Home series emergency power supply in the TN-C network



Tip **:
 The necessity of using an RCBO to pre-fuse the battery depends on the structure of the customer system. The decision on installation is the responsibility of the specialist carrying out the work.
 The use of individual RCBOs with several batteries will lead to 'false triggers'.
 The SAX home storage unit is a stationary device. (see VDE 0100-200).

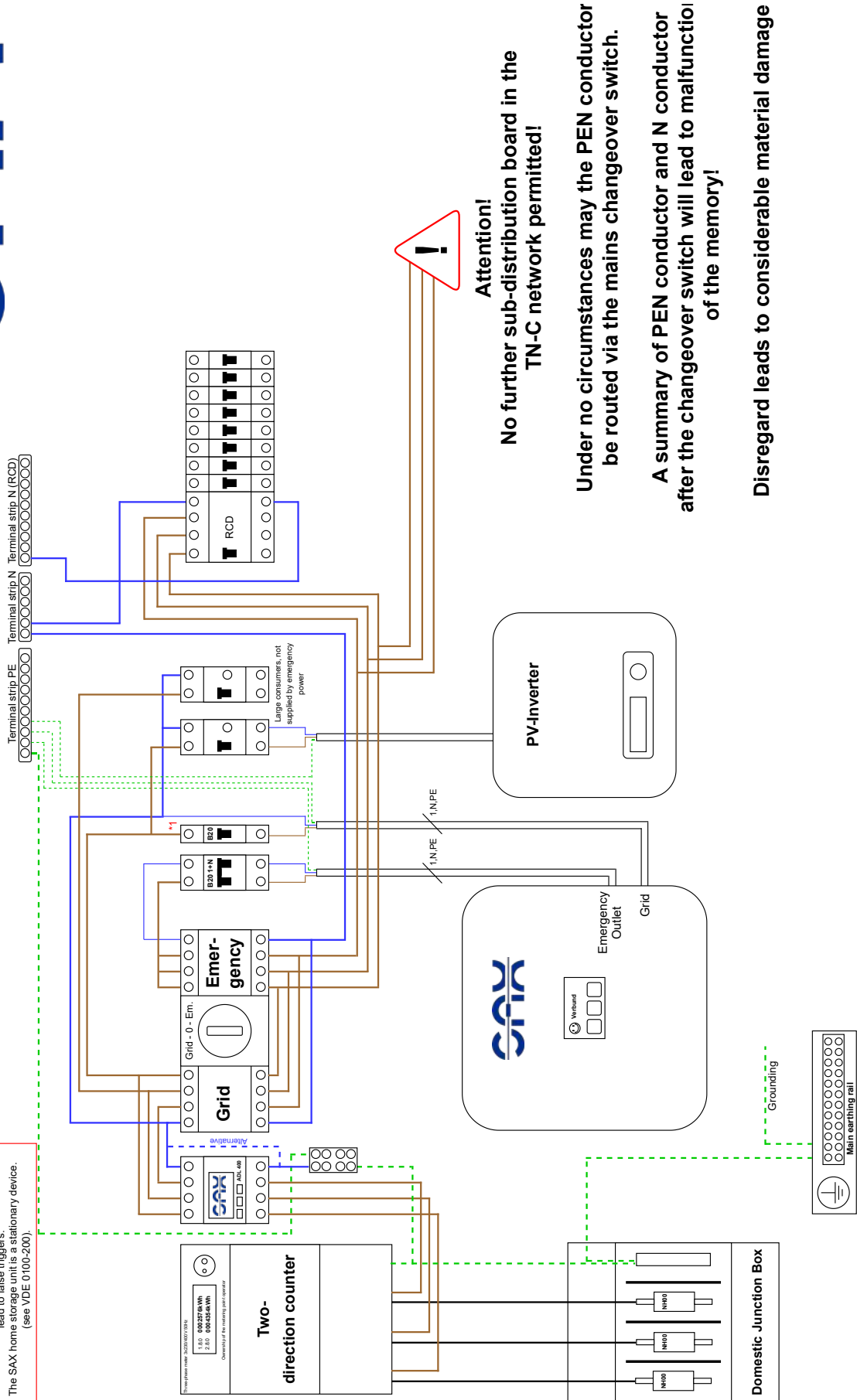

Fig. 62 Connection diagram for Backup Power supply with stand-alone operation in the TN-CS/ TN-S network

Connection diagram for backup power supply with island operation SAX Power Home series in the TN-C-S/TN-S grid



Tip *1:
The necessity of using an RCBO to pre-use the battery depends on the structure of the customer system. The decision on installation is the responsibility of the specialist carrying out the work. The use of individual RCBOs with several batteries will lead to false triggers. The SAX home storage unit is a stationary device. (see VDE 0100-200).

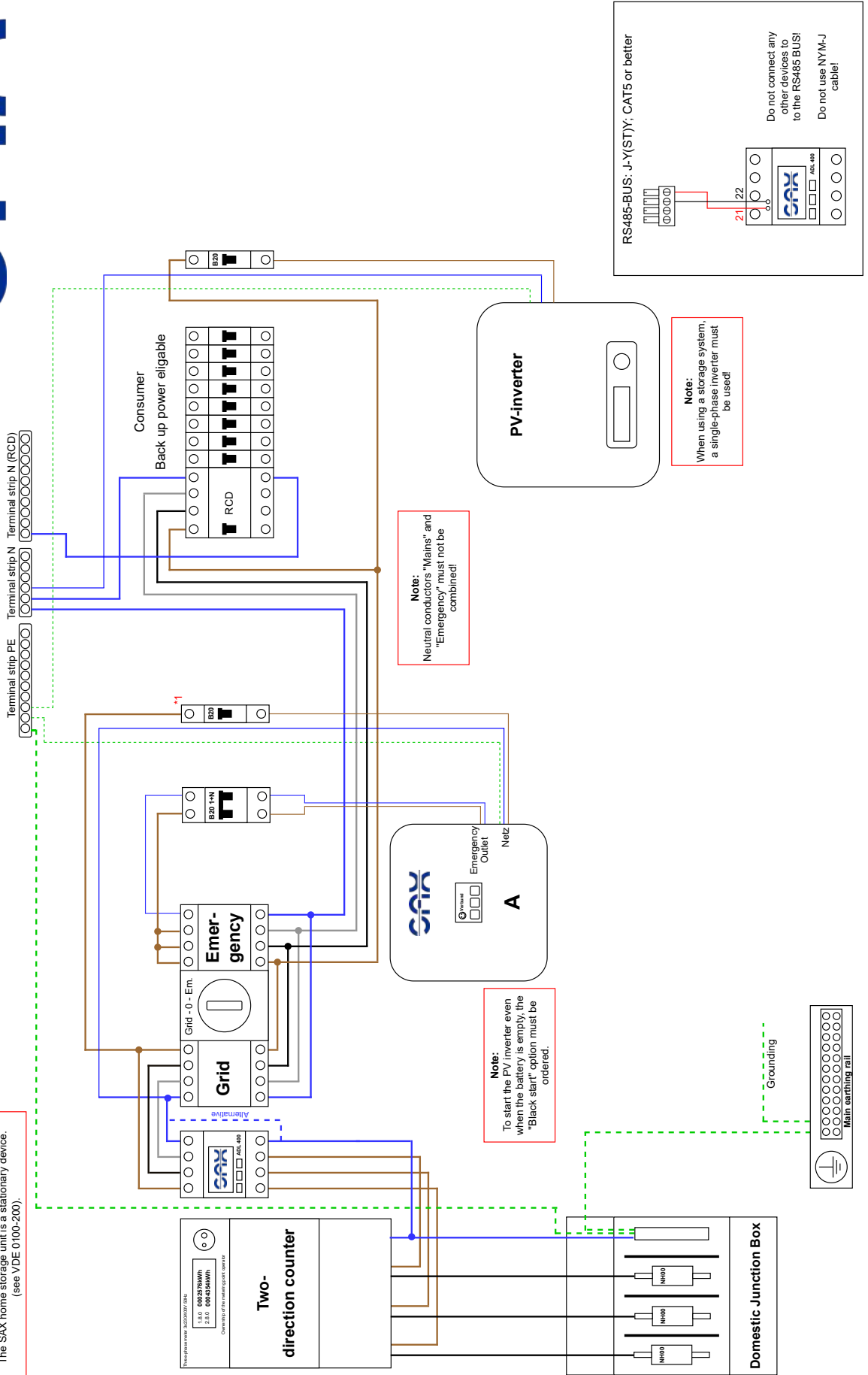

Fig. 63 Connection diagram for Backup Power supply with stand-alone operation in the TN-CS/ TN-S network

Connection diagram for backup power supply with island mode SAX Power Home series in the TT grid



Tip #1:
The necessity of using an RCBO to pre-fuse the battery depends on the structure of the customer system. The decision on installation is the responsibility of the specialist carrying out the work.
The use of individual RCBOs with several batteries will lead to false triggers.
The SAX home storage unit is a stationary device. (see VDE 0100-200).

Tip #2:
Additional protective devices required due to the type of grid, such as an RCD to comply with the switch-off conditions, can be found in the technical connection conditions of the distribution grid operator.
The illustration in this connection diagram is purely exemplary.

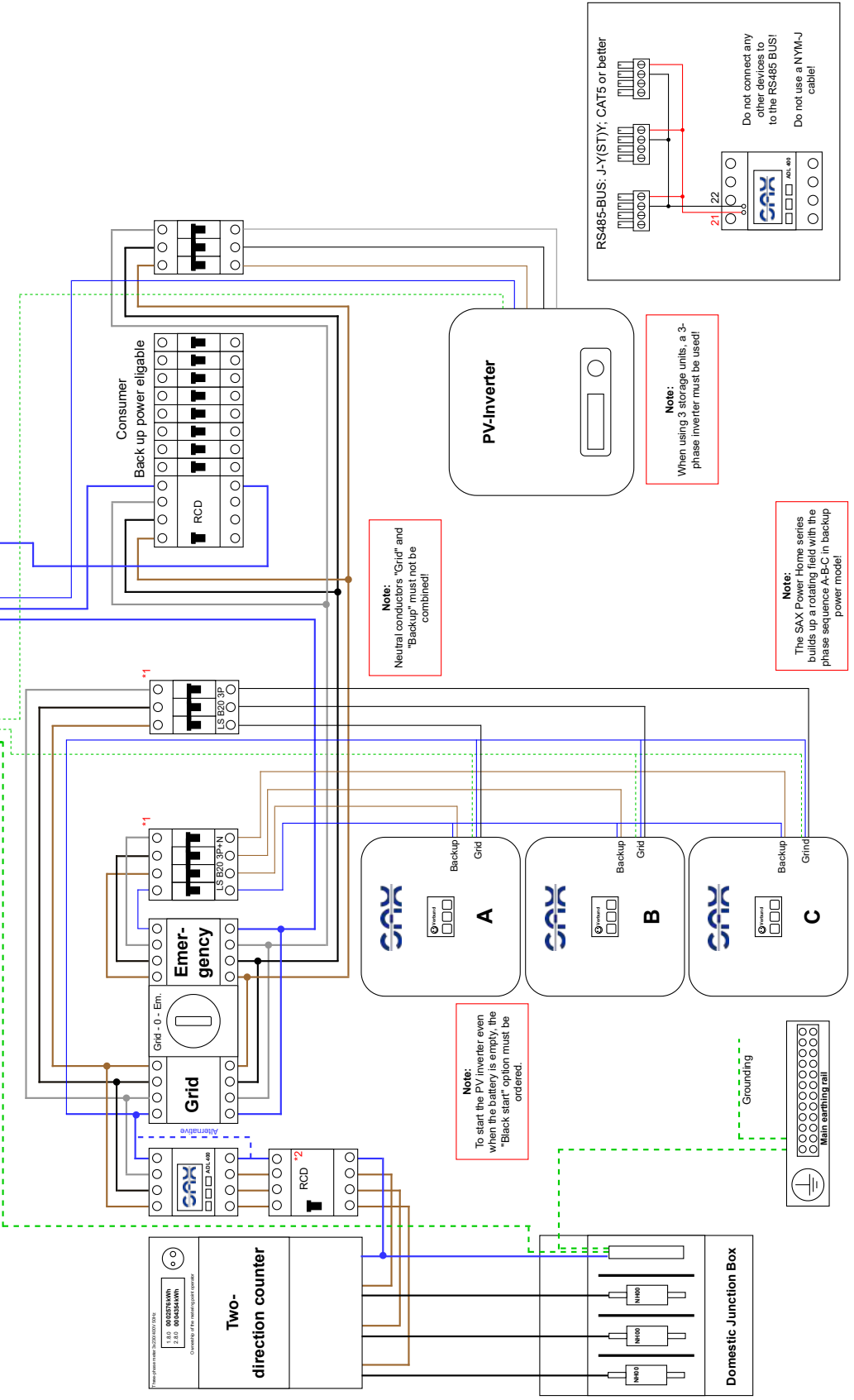
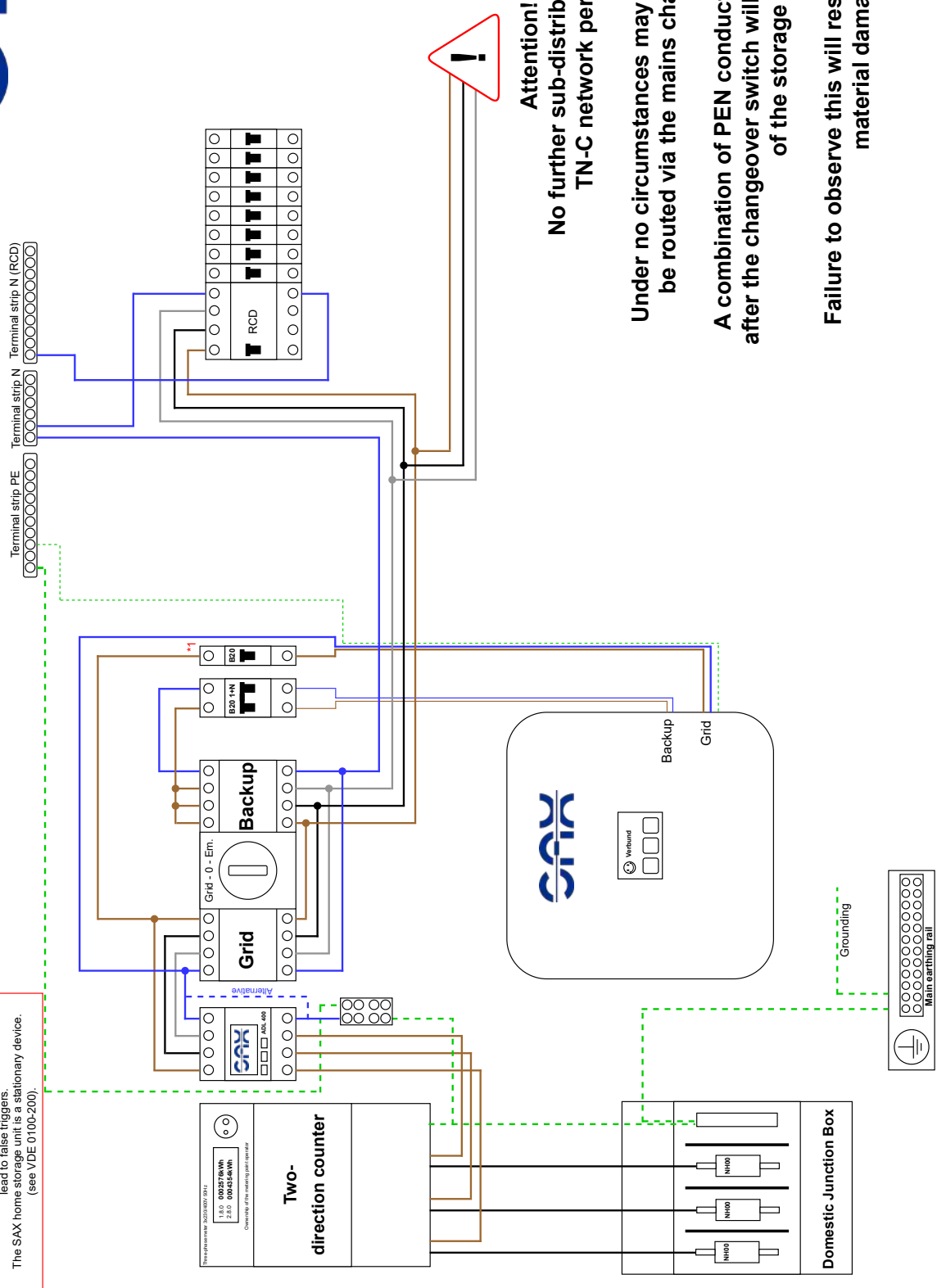

Fig. 64 Connection diagram for Backup Power supply with stand-alone operation in the TT grid

Connection diagram for SAX Power Home series emergency power supply in the TN-C network



Tip *1:
 The necessity of using an RCBO to pre-fuse the battery depends on the structure of the customer system. The decision on installation is the responsibility of the specialist carrying out the work.
 The use of individual RCBOs with several batteries will lead to false triggers.
 The SAX home storage unit is a stationary device. (see VDE 0100-200).



Attention!
 No further sub-distribution in the TN-C network permitted!

Under no circumstances may the PEN conductor be routed via the mains changeover switch.
 A combination of PEN conductor and N conductor after the changeover switch will lead to malfunctions of the storage unit!

Failure to observe this will result in considerable material damage!

Fig. 65 Connection diagram for Backup Power supply with stand-alone operation in the TN-C grid

9 Commissioning

Prerequisite for commissioning: Smartmeter has been installed correctly (correct connection of the hinged current transformers on the ADW200), the storage unit has been installed and the following connections have been checked:

- Grid connection.
- Backup Power connection if necessary.
- Internet connection (see chapter 7.2 Establishing an Internet connection).
- Smart meter connection (see chapter 7.3 Establishing a communication connection).

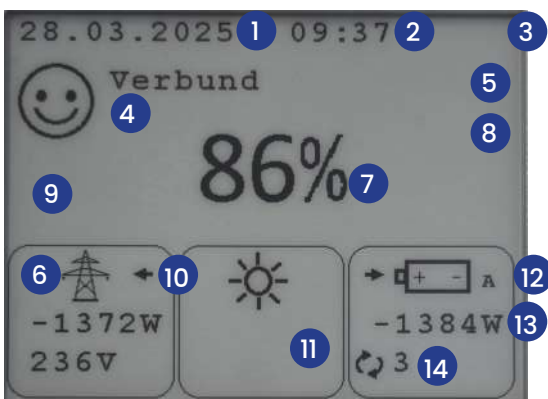

Fig. 66 Display after correct installation

1. Current date
2. Current time
3. Connection status to the web server, without status (LAN = ok)
4. Storage status display
5. Extended status display, without status
6. Display for grid errors (see error code list)
7. Charge level display
8. Display for device errors, without status (see error code list)
9. IP address of the storage
10. →Power consumption from the public grid
←Surplus feed-in to the public grid
11. Display generation system (only with ADW200)
12. Display of the grid phase
13. →Charging power
←Discharging power
14. Charging cycles

9.1 Initial commissioning step by step:

1. Execution and logging of all necessary measurements in accordance with VDE 0100 at the grid connection.
2. Switch on the fuse, the display is updated.
3. Switch on the storage tank at the main switch on the left.
4. Switch-on procedure begins, "Wait 60 seconds" appears.
5. Storage unit performs a relay test (loud clacking).
6. Storage unit switches on.
7. Storage unit starts a "SM test" (smart meter test).
8. If the smart meter test is passed "Connected".



Attention: Once the SM test has been carried out, the installation direction of the smart meter must not be changed

9. Observe error messages on the display; in case of errors, see chapter "Operating messages, problems and solutions".
10. Set up the web app.

Subsequent self-checks for the correct function of the storage unit:

- Switch off the generating plant.
- Switch on loads in the house (>2kW) and check in the web app whether the storage capacity increases by >2kW.
- The grid power should be adjusted to a value between -100W and +100W.
- If the UPS is active and the Backup Power socket is connected, connect the load to the Backup Power output and release the circuit breaker of the storage unit. The load must continue to run!



Calibration Notes:

The storage system performs a calibration charge to improve the accuracy of the state-of-charge display, balance the cell voltages, and maximize the usable capacity of the system. If the storage is not regularly cycled to its full range (0% to 100% state of charge), a calibration cycle will automatically be triggered at 1000 W. During this process, the display shows the message "Calibrate Battery", and the dashboard will indicate a charge or discharge of exactly 1000 W.

Note: On older firmware versions, this calibration message may not appear on the display.

10 Web server and app

You can monitor the storage system via a web interface and an app. The storage system is connected to the SAX Power GmbH web server via the Internet.

Open the following Internet address in your browser:
<https://app.sax-power.net>



10.1 Register in the web server

1. Click on "Create an account" when you log in for the first time. Enter your e-mail address and the registration code, which you will find on the supplementary sheet, and assign a personal password.
2. Click on "Register". You have now created an account and can log in with your e-mail address and password.

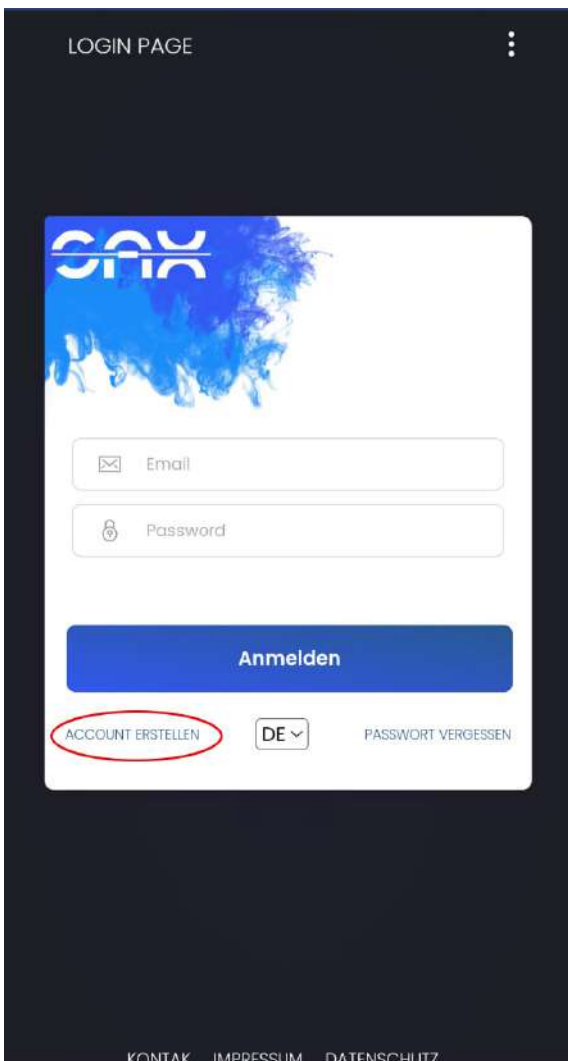

Fig. 67 Web app login page

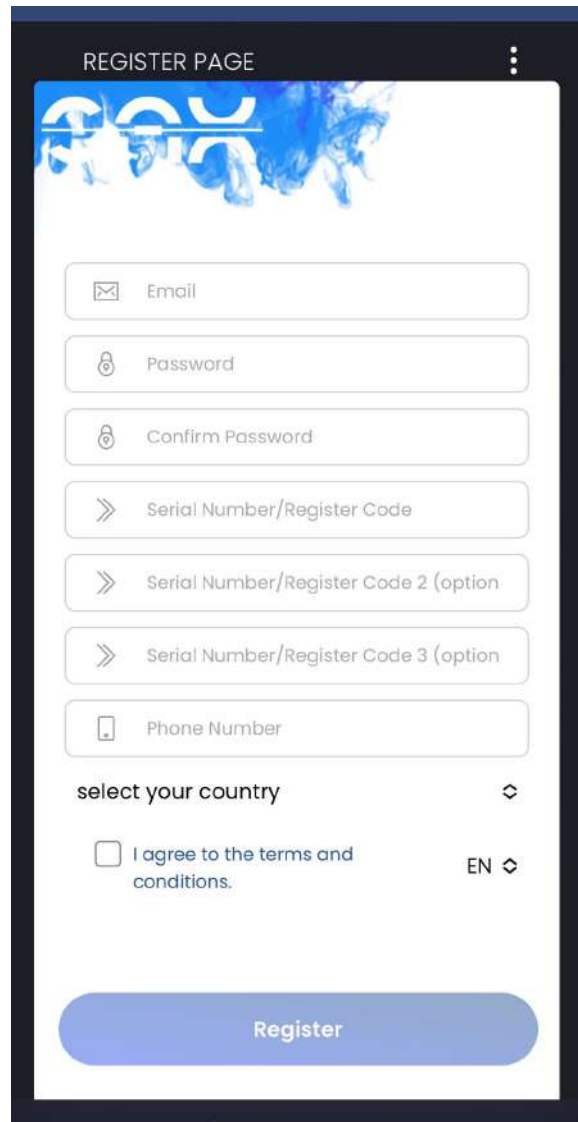

Fig. 68 Web app registration page

10.2 Installing the app for the smartphone (Android)

1. An app can be downloaded to the smartphone via the Internet browser, in which the same data is displayed as in the browser. To do this, navigate to the login page in the browser and install the app via the browser menu.

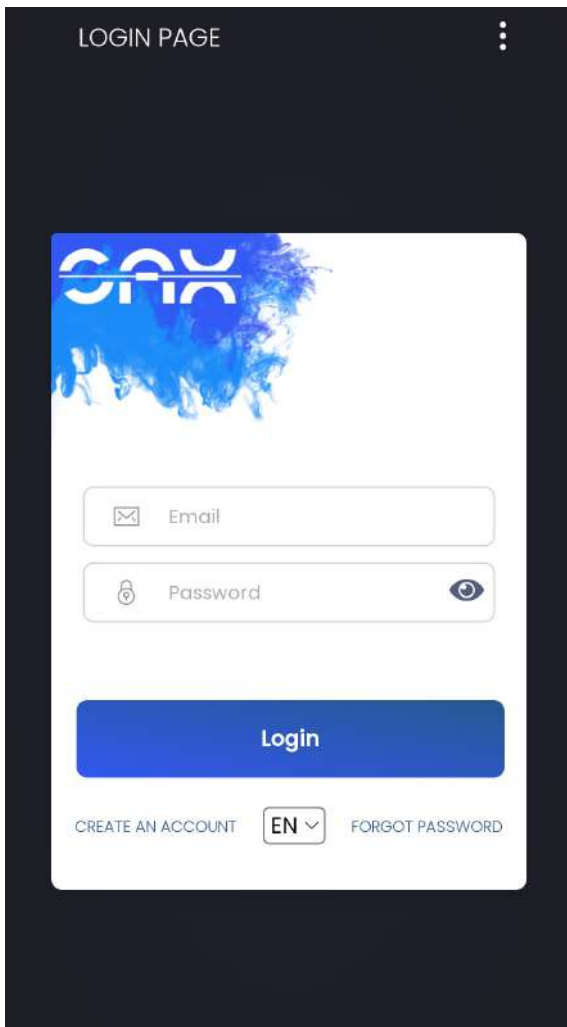

Fig. 69 Web app login page



Abb. 70 Install app

2. After successfully logging in, the SAX Power Dashboard opens.

10.3 Installing the app for the smartphone (Apple iOS)

1. Enter the URL app.sax-power.net in the search bar.
2. Open submenu in Safari.
3. Select the Home screen item in the submenu.

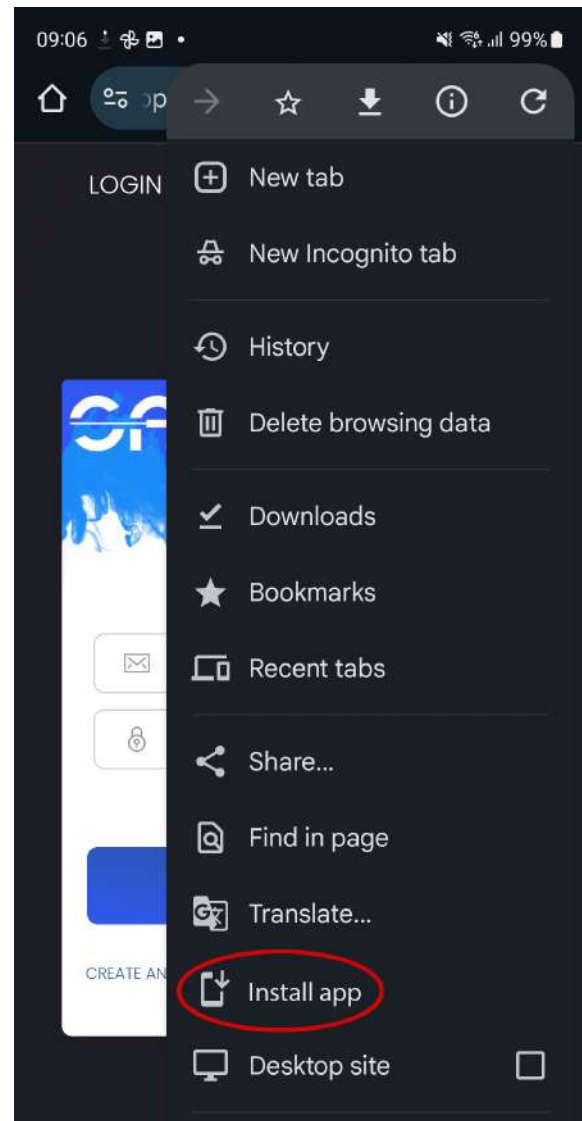
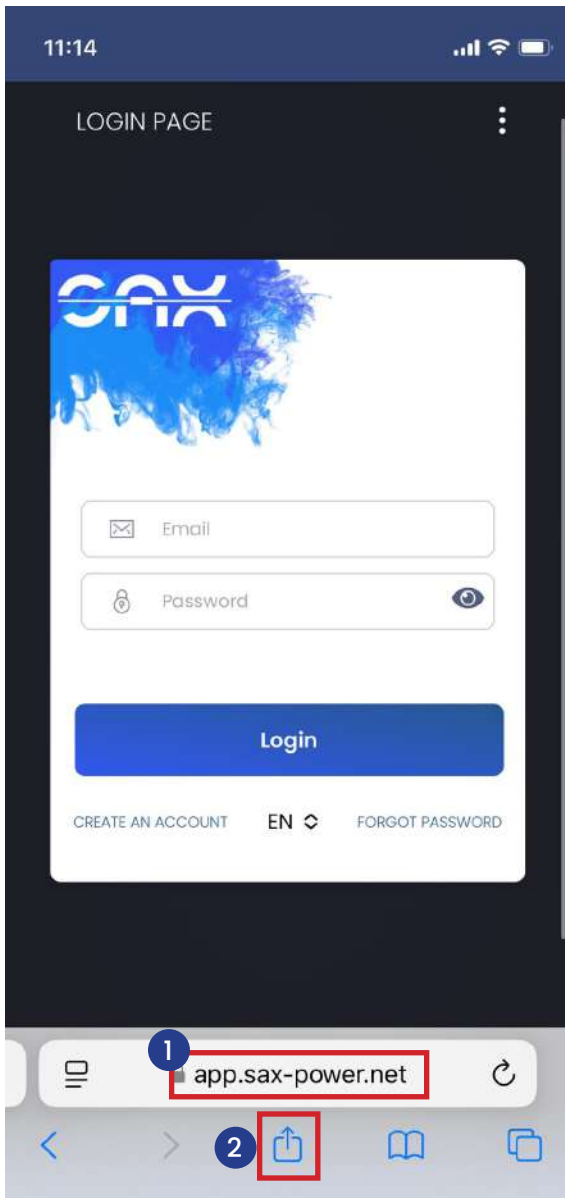

Fig. 71 Apple (iOS) Web app login page

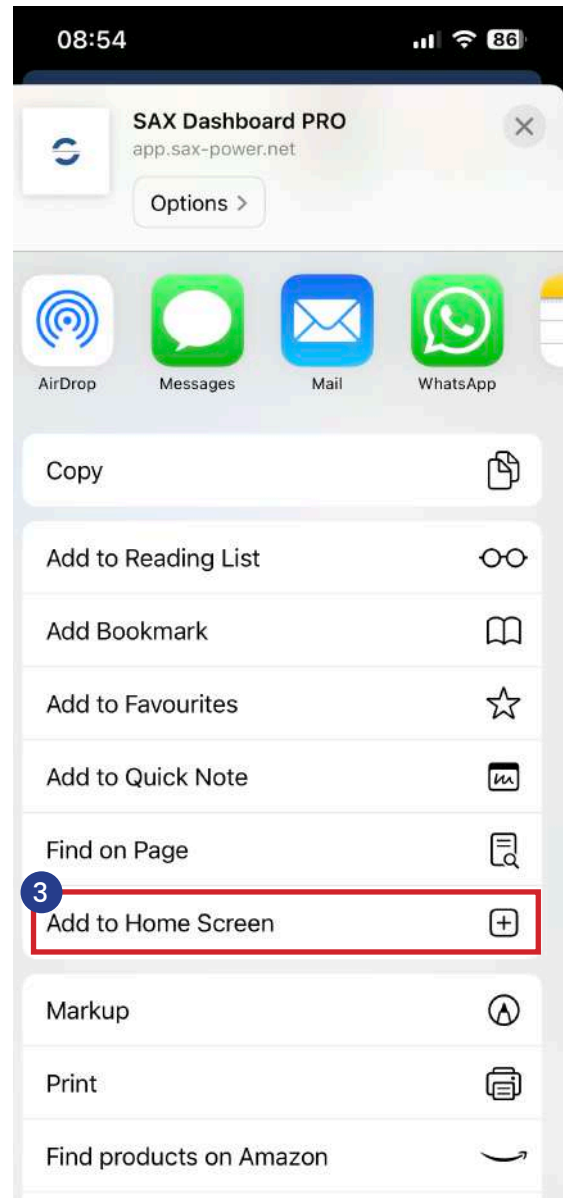

Fig. 72 Add to home screen

4. Enter any name.
5. Press Add to confirm.

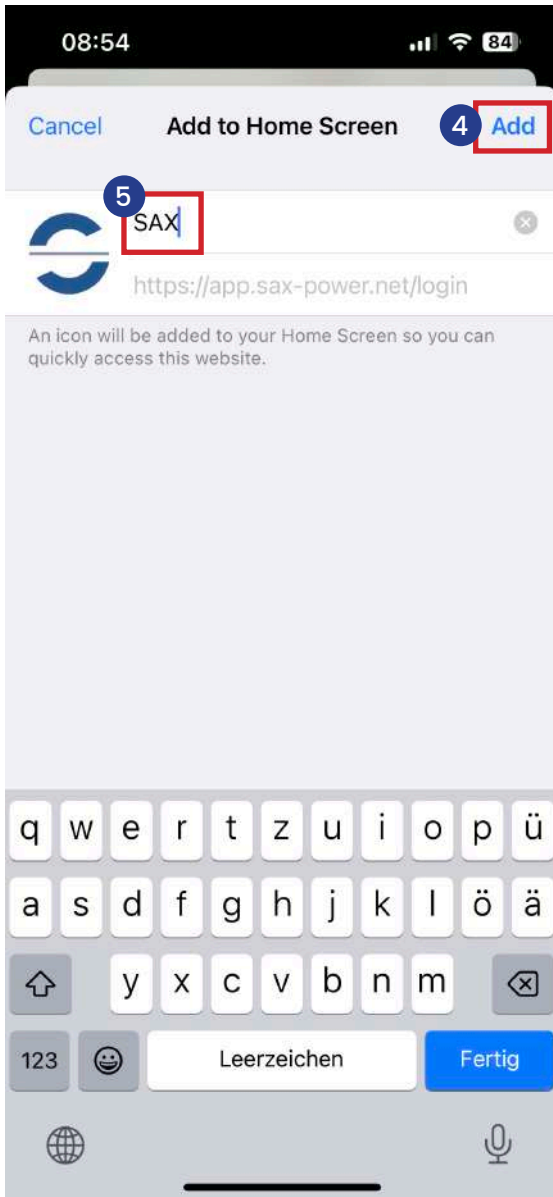

Fig. 73 Naming the web app icon



Fig. 74 Web app icon on home screen

10.4 The SAX Power Dashboard



Abb. 75 Dashboard

Overview of the dashboard:

- | | | | |
|------|---------------------------------------|-----|-------------------------|
| 1. | General settings. | 9. | Error message. |
| 2-5. | Current values. | 10. | Grid power. |
| 6. | Diagram. | 11. | PV power. |
| 7. | Animation of the energy flow. | 12. | Storage capacity. |
| 8. | Operating status of the storage unit. | 13. | State of charge. |
| | | 14. | NA protection messages. |

11 Supported protocols

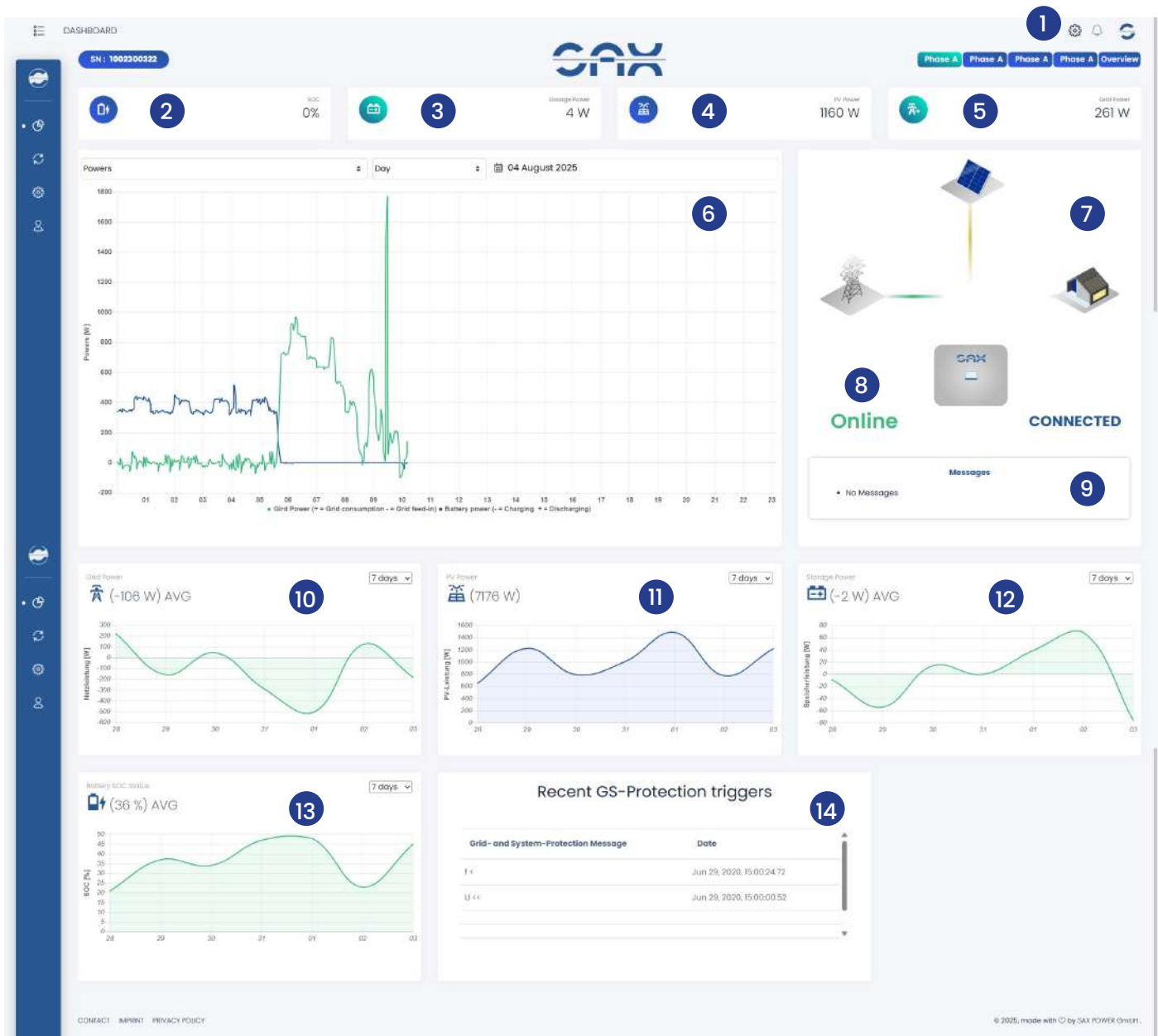
This chapter is relevant for customers who want to configure the backup function in the Smart Home installation, i.e. read out the backup from an external unit. Modbus is an industry standard with which other devices can easily integrate and address the SAX Power Home (Plus). This means that systems from different manufacturers can be easily combined. Set values for active power and limit values for active power can be sent to the storage system. In addition, the state of charge (SOC) and the current output of the storage system can be read out. The protocols used by the storage system are described below.

11.1 Modbus TCP Control

Instructions for using the Modbus TCP interface: The storage unit offers a Modbus TCP interface via which communication is possible. This makes it possible not only to read out data, but also to write data to the storage unit.

Prerequisites

- Network access: The storage unit must be connected to the local network.
- IP address: The IP address of the storage device must be known.
- Modbus client software: A corresponding programme or tool for communication via Modbus TCP is required. (e.g. Modbus Poll, customised control software, etc.)

Establish connection

1. Network connection: Make sure that the storage unit is located in the same network segment as your computer or control system.
2. Configuring the Modbus client
 - Enter the IP address of the storage unit.
 - Select port 502 (standard port for Modbus TCP).
 - Configure the query parameters according to the following table.

Various slave IDs are available for control via Modbus TCP. The corresponding register lists apply depending on the ID used.

Note:



With Modbus TCP, a distinction is made between internal addresses and protocol addresses. If the read/write function is already specified in the client, the internal register address must be used. The register offset for function 03 (Read Holding Registers) is 40001, so to access the protocol address 40042, the internal register address 41 must be read.

11.2 Modbus TCP Basic Mode

Modbus Basic Mode is available to enable integration into energy management systems. This basically distinguishes between two operating modes, which can be selected via the customer service or the configuration software (parameter setting programme).

Smart Meter operating mode (RS485)

- Control of the storage unit is always zero control via the SAX Power Smart Meter.
- Values such as SOC, instantaneous power of the storage system and power at the grid connection point can be read out.
- Limit values for charging / discharging power can be written.

P setpoint operating mode (TCP)

- There is no regulation via the SAX Power Smart Meter. The storage system only works on the basis of the specified setpoints.
- Values such as SOC, instantaneous power of the storage system and power at the grid connection point can be read out.
- Setpoints must be specified to operate the storage unit.
- The power gradient of the setpoint control is 0.27%/s ex works.

The unit-ID in basic mode is always 0x40 (64).

Write commands must be repeated periodically. Repetition is recommended here at least every 5 minutes, but no more than every 5 seconds.

11.3 Slave-ID 64: Values - SAX Power Home (Plus)

Protocol address	Internal address	Designation	Unit	Unit-ID	Hint	Data typ	Access type
40042	41	Setpoint power P	Watt	64	(1)	uint16	Write
40043	42	Setpoint cos(Phi)	-	64	(1)	uint16	Write
40044	43	Power limit value for discharge	Watt	64	(2)	uint16	Write
40045	44	Power limit value for charge	Watt	64	(2)	uint16	Write
40046	45	Switching state of the storage unit	-	64	(3)	uint16	Read/Write
40047	46	SOC of the storage unit (measured value)	Prozent	64		uint16	Read
40048	47	Power P of the storage unit (measured value)	Watt	64		uint16	Read
40049	48	Power of the smartmeter	Watt	64		uint16	Read

(1) Note: Only available in P setpoint (TCP) operating mode.

(2) Note: 43, 44 are only available after activation.

(3) Note: There are two commands for Write: "Off" 01 and "On" 02.
There are three commands for Read: "Off" 01 "On" 02 and "Connected" 03.

11.4 Modbus-TCP Slave Extended Mode

This operating mode enables extended control of the storage unit and the reading of extended parameters from the connected smart meter.

Different slave IDs must be used here; these can be found in the corresponding table.

11.5 Slave-ID 40: Werte - SAX Power Home (Plus)

Protocol address	Internal address	Designation	Unit	Unit-ID	Hint	Data type	Access type
40071	70	SunSpec ID	-	40	-	uint16	Read
40072	71	SunSpec Length	-	40	-	uint16	Read
40073	72	Total phase currents	A	40	-	uint16	Read
40074	73	Current L1	A	40	-	uint16	Read
40075	74	Current L2	A	40	-	uint16	Read
40076	75	Current L3	A	40	-	uint16	Read
40077	76	Current scaling	sunssf	40	Scaling factor: -2	sunssf	Read
40078	77	N.A.	-	40	-	-	Read
40079	78	N.A.	-	40	-	-	Read
40080	79	N.A.	-	40	-	-	Read
40081	80	Voltage L1	V	40	-	uint16	Read
40082	81	Voltage L2	V	40	-	uint16	Read
40083	82	Voltage L3	V	40	-	uint16	Read
40084	83	Voltage scaling	-	40	Scaling factor: -1	-	Read
40085	84	Total power AC (active)	W	40	Scaling factor: 1	int16	Read
40086	85	Scaling total power (active)	sunssf	40	-	int16	Read
40087	86	Grid frequency	Hz	40	-	uint16	Read
40088	87	Grid frequency scaling	sunssf	40	Scaling factor: -1	sunssf	Read
40089	88	Total power AC (apparent)	VA	40	-	int16	Read
40090	89	Scaling total power (apparent)	sunssf	40	Scaling factor: 1	sunssf	Read
40091	90	Total power AC (reactive)	VAr	40	-	int16	Read
40092	91	Scaling total power (reactive)	sunssf	40	Scaling factor: 1	sunssf	Read
40093	92	Power factor	Per cent	40	-	int16	Read
40094	93	Power factor scaling	sunssf	40	Scaling factor: -1	sunssf	Read



Note: The scaling factor is to be regarded as an exponent of 10. A scaling factor of -1 therefore corresponds to a multiplier of 0.1.

11.6 Slave-ID 40: Values – Smartmeter

Protocol address	Internal address	Designation	Unit	Unit-ID	Hint	Data type	Access type
40095	94	N.A.	-	40	-	-	Read
40096	95	Energy fed in	kWh	40	-	uint16	Read
40097	96	Energy related	kWh	40	-	sunssf	Read
40098	97	Energy scaling	sunssf	40	Scaling factor: 1	-	Read
40099	98	Switching state of the memory	-	40	(i)	uint16	Read
40100	99	Current L1	A	40	Scaling factor: -2	int16	Read
40101	100	Current L2	A	40	Scaling factor: -2	int16	Read
40102	101	Current L3	A	40	Scaling factor: -2	int16	Read
40103	102	Active power L1	W	40	-	int16	Read
40104	103	Active power L12	W	40	-	int16	Read
40105	104	Active power L13	W	40	-	int16	Read
40106	105	Power scaling	sunssf	40	Scaling factor: 1	sunssf	Read
40107	106	Voltage L1	V	40	-	int16	Read
40108	107	Voltage L2	V	40	-	int16	Read
40109	108	Voltage L3	V	40	-	int16	Read
40110	109	Total power (active)	W	40	-	int16	Read



Note: The scaling factor is to be regarded as an exponent of 10. A scaling factor of -1 therefore corresponds to a multiplier of 0.1.

11.7 Slave-ID 123: Immediate Controls



Note: Will be supported with future software versions. (As of 03/25 not yet available)

Protocol address	Internal address	Designation	Unit	Unit-ID	Hint	Data type	Access type
40349	348	Power setpoint	%	123	Scaling factor: 100 -10000 ... +10000	int16	Read/Write
40353	352	Control mode (limiting)	-	123	(2)	int16	Read/Write

(1) Note: 1= OFF ; 2= ON ; 3= Connected ; 4= Standby

(2) Note: 0= Control via smart meter

1 = Setpoint control. If no new value is set for 5 minutes, control via smart meter (0) is automatically reactivated.



Note: Both registers must be written at the same time for successful setpoint control.

12 Decommissioning

To decommission, simply switch off the main switch. When switched off the storage unit is below the safety voltage (20V).

Attention:

Only switch off the storage unit for a longer period of time if the remaining charge level is at least 50%. This is necessary to protect the battery cells from deep discharge. Switch on the storage unit at least once **every 6 months** to prevent the battery cells from discharging too deeply.

13 Technical Data

13.1 SAX Power Home System data

Battery type	LiFePO4
Cell data	3.2V; 15Ah
Usable capacity	5.2kWh
Modularly expandable	up to 17.3kWh (3 storage units)
Nominal voltage	230V AC 1 phase
Rated power normal	4.6kVA
Rated current normal	20A
Storage weight	52kg
Storage dimension	530mm x 530mm x 250mm
Standby power / consumption	approx. 4W

13.2 SAX Power Home Operating data

All-in-One	Inverter not necessary
Efficiency for the conversion	98.6%
Backup Power function	Yes
Communication	Modbus-RTU, Modbus-TCP/UDP
Communication connections	RS485, RJ45 (LAN)
Warranty on the battery	10 years > 80%
Ambient temperature (operation)	+5°C to +35°C
Ambient temperature (storage, transport)	-10°C to +40°C
Dust and water protection	IP 30
Certification	DE, AT, CH, FR, BE, PL VDE-AR-N 4105, UN 38.3
Protection class	1 (protective earthing)

13.3 SAX Power Home Plus system data

Battery type	LiFePO4
Cell data	3.2V; 20Ah
Usable capacity	7.0kWh
Modularly expandable	up to 23kWh (3storage units)
Nominal voltage	230V AC, 1 phase
Rated power normal	4.6kVA
Rated current normal	20A
Storage weight	72kg
Storage dimension	620mm x 620mm x 250mm
Standby power / consumption	approx. 4W

13.4 SAX Power Home Plus operating data

All-in-One	Inverter not necessary
Efficiency for the conversion	98.6%
Backup Power function	Yes
Communication	Modbus-RTU, Modbus-TCP/UDP
Communication connections	RS485, RJ45 (LAN)
Warranty on the battery	10 years > 80%
Ambient temperature (operation)	+5°C to +35°C
Ambient temperature (storage, transport)	-10°C to +40°C
Dust and water protection	IP 30
Certification	DE, AT, CH, FR, BE, PL VDE-AR-N 4105, UN 38.3
Protection class	1 (protective earthing)

13.5 SAX Power Smartmeter ADL400

Nominal voltage	3 x 230/400V
Consumption	<10VA (one phase)
Impedance	>2MΩ
Input current	3 x 10(80)A
Electricity consumption	<1VA
Accuracy	±0.2%
Clock accuracy	≤0.5s/d
Pulse bandwidth	80 ± 20ms
Communication - Connection	RS485
Communication - Protocol	Modbus-RTU
Working temperature range	-25°C ~ +55°C
Storage temperature range	-40°C ~ +70°C
Air humidity	≤95% (no condensation)
Height	<2000m

13.6 SAX Power Smartmeter ADW200

Nominal voltage	3 x 230/400V
Reference frequency	50Hz
Consumption	<10VA (one phase)
Input current	3 x 20(100)A
Electricity consumption	<2VA
Communication - Connection	RS485
Communication - Protocol	Modbus RTU, DL/T 645-07
Working temperature range	-25°C ~ +55°C
Storage temperature range	-40°C ~ +70°C
Air humidity	≤95% (no condensation)
Height	<2000m

14 Operational messages, problems and solutions

Typical problems during installation:

Problem	Possible cause	Solution
No connection to the web server	DHCP server not correctly configured	Configure the DHCP server so that sufficient IP addresses are available.

Messages are shown with abbreviations on the display and in the web server. Their meanings with the corresponding actions are described in the following table:

	Abbreviation	Meaning and behaviour	Possible measures
1	OFF	Storage unit is switched off.	Operating status message, no action required.
2	ON	Storage unit is switched on.	Operating status message, no action required.
3	Connected	Storage unit is switched on and connected to the grid.	Operating status message, no action required.
4	Standby	Storage unit is in standby mode and switches on when the solar system feeds power to the grid.	Operating status message, no action required.
5	Wait 60s	Waiting for stable grid conditions.	Operating status message, no action required.
6	SM Test	Automatic test of the smart meter.	Operating status message, no action required.

7	U>>	<p>Grid voltage too high.</p> <p>2nd overvoltage stage is triggered.</p> <p>Storage unit switches off.</p>	<p>Checking the grid connection and grid voltage.</p> <p>Storage unit switches on automatically when the grid voltage is back within the permissible range.</p>
8	U>	<p>Grid voltage too high.</p> <p>1st overvoltage stage is triggered.</p> <p>Storage unit switches off.</p>	<p>Checking the grid connection and grid voltage.</p> <p>The storage unit switches on again automatically when the grid voltage is back within the permissible range.</p>
9	U<<	<p>Grid voltage too low.</p> <p>2nd undervoltage stage is triggered.</p> <p>Storage unit switches off.</p>	<p>Checking the grid connection and grid voltage.</p> <p>The storage unit switches on again automatically when the grid voltage is back within the permissible range.</p>
10	U<	<p>Grid voltage too low.</p> <p>1st undervoltage stage is triggered.</p> <p>Storage unit switches off.</p>	<p>Checking the grid connection and grid voltage.</p> <p>The storage unit switches on again automatically when the grid voltage is back within the permissible range.</p>
11	f >	<p>Grid frequency too high.</p> <p>Storage unit switches off.</p>	<p>Checking the grid voltage.</p> <p>Storage unit switches on again automatically when the grid frequency is back within the permissible range.</p>
12	f <	<p>Grid frequency too low.</p> <p>Storage unit switches off.</p>	<p>Checking the grid voltage.</p> <p>Storage unit switches on again automatically when the grid frequency is back within the permissible range.</p>
13	Island	<p>The storage unit is disconnected from the grid.</p> <p>Storage unit switches off.</p>	<p>Checking the grid connection and grid voltage</p> <p>The storage unit switches on again automatically when the grid voltage is back within the permissible range.</p>
14	HW!	<p>Hardware error in the storage unit. The storage unit switches off or can no longer be switched on.</p>	<p>Switch the grid switch off and on again. If this message is still present, contact the supplier.</p>

15	MR!	Communication error to the gateway Storage unit remains in operation. Display on the display and web server is incorrect.	Switch the main switch off and on again. If this message is still present, contact the supplier. Continued operation of the storage unit is possible. Connection to web server and display is faulty. Measured values and messages may be displayed incorrectly.
16	MT!	Communication error to the gateway Storage unit remains in operation. Display on the display and web server is incorrect	Switch the main switch off and on again. If this message is still present, contact the supplier. Continued operation of the storage unit is possible. Connection to web server and display is faulty. Measured values and messages may be displayed incorrectly.
17	SM!	Communication error with the smart meter The storage unit switches off or can no longer be switched on.	Check the connection cable to the smart meter and storage unit. If the operating mode "Power control according to a setpoint value from RS485" is selected, this error is displayed if the storage unit does not receive a power setpoint value for 10 seconds. Errors may be due to the communication path or Modbus protocol.
18	SM2!	Incorrect switching of the smart meter The storage unit switches off after an automatic test.	Check connections of measuring devices for voltages and currents. The phase assignment of the voltage and current measurements may be incorrect. Folding current transformers may not be closed properly. Once the fault has been rectified, the storage unit can be switched on again using the main switch.
19	I>	Storage unit overload. Storage unit switches off.	The storage unit switches on again automatically when the grid voltage is back within the permissible range. If the error remains after three restarts, the storage unit will no longer switch on automatically. Switch off the storage unit with the main switch, find and rectify the short circuit or overload and then switch it on again.

20	I>>	Short circuit Storage unit switches off.	The storage unit switches on again automatically when the grid voltage is back within the permissible range. If the error remains after three restarts, the storage unit will no longer switch on automatically. Switch off the storage unit with the main switch, find and rectify the short circuit or overload and then switch it on again.
21	!l	Error in current measurement Storage unit switches off.	Switch the main switch off and on again. If this message is still present, contact the supplier.
22	U!	Error in the voltage measurement The storage unit switches off or can no longer be switched on.	Switch the main switch off and on again. If this message is still present, contact the supplier.
23	Rel!	Error of a coupling switch The error after an automatic test when switching on. The storage unit can no longer be switched on.	Switch the main switch off and on again. If this message is still present, contact the supplier.
24	Bat!	Battery voltage too high or too low Battery temperature too high The storage unit switches off or can no longer be switched on.	Switch off the storage unit with the main switch, wait 30 seconds, connect to the grid and switch on again. Switch on. If this message is still pending, contact the supplier.



www.sax-power.net