



Air Cooling Energy Storage System

**AELIO-P50B100 / AELIO-P60B100 /
AELIO-P50B100-AU / AELIO-P60B100-AU**

Installation Manual

Version 7.0

www.solaxpower.com



Printed in the UK, code 07
at www.solaxpower.com

Table of Contents

Safety.....	1
Preparation before Installation	9
Mechanical Installation.....	16
Electrical Connection	20
Power on and off the System	33
LED Indicators	34
System Configuration.....	34

Safety

















General Notice

1. Contents may be periodically updated or revised. SolaX reserves the right to make improvements or changes in the product(s) and the program(s) described in this manual without the prior notice.
2. The installation, maintenance and grid-related setting can only be performed by qualified personnel who:
 - Are licensed and/or satisfy state and local jurisdiction regulations;
 - Have good knowledge of this manual and other related documents.
3. Before installing the device, carefully read, fully understand and strictly follow the detailed instruction of the user manual and other related regulations. SolaX shall not be liable for any consequences caused by the violation of the storage, transportation, installation, and operation regulations specified in this document and the user manual.
4. Use insulated tools when installing the device. Individual protective tools must be worn during installation, electrical connection and maintenance.
5. Please visit the website www.solaxpower.com of SolaX for more information.

Safety Instruction

For safety reasons, installers are responsible for familiarizing themselves with the contents of the Manual and all warnings before performing installation.

Descriptions of Labels

	CE mark of conformity		TUV certification
	RCM mark of conformity		Grounding point
	Additional grounding point		Caution, risk of danger
	The battery module may explode.		Caution, risk of electric shock
	Caution, hot surface		Read the enclosed documentations.
	Keep the battery system away from children.		Do not dispose of the battery module together with household waste.
	Keep the battery system away from open flames or ignition systems.		Do not operate this inverter until it is isolated from mains and on-site PV generation suppliers.
	The battery system must be disposed of at a proper facility for environmentally-safe recycling.		
	Danger of high voltage. Do not touch live parts of the cabinet for 15 minutes after disconnection from the power sources.		
	Danger of high voltage. Do not touch live parts of the inverter for 5 minutes after disconnection from the power sources.		

 **DANGER!**

- According to the local laws and regulations related to high-altitude work, operators must wear PPE, e.g., a helmet, safety belt, or waist harness, when they work at heights, while the other end of the harness must connect to a secure structure to prevent fall incidents.

 **DANGER!**

- Do not connect the positive and negative poles of a battery together. Otherwise, it may be short-circuited. This will result in an excessive flow of current and large quantities of energy for a short time, and then will cause battery leakage, smoke, the emission of flammable gases, thermal runaway, fire, or even an explosion. Therefore, the battery must be powered off before maintenance.
- If a battery is overheated, it will cause leakage, smoke, release of flammable gases, thermal runaway, fire, or even an explosion. Therefore, please ensure that the installation site shall be well ventilated and kept away from high temperatures.
- Do not dismantle, change, shake, drop, crush, impact, cut, penetrate with a sharp object, or any other ways to damage the battery. Otherwise, it may cause leakage, smoke, emission of flammable gases, thermal runaway, fire, or even an explosion.
- Do not mix different types or makes of the battery. Otherwise, it may cause leakage or rupture, resulting in personal injury or property damage.
- The battery electrolyte is toxic and volatile. Never get in contact with the leaked liquids or inhale gases in the case of the battery leakage or odor, and contact professionals immediately. The professional must wear PPE (including but not limited to safety glasses, safety gloves, gas masks, and protective clothing) before powering off the device, and then contact our company at once after removing the damaged battery.
- Normally, the battery will not release any gases. However, in the following situations: burnt, needle-pricked, squeezed, struck by lightning, overcharged, or subject to other adverse conditions that may cause battery thermal runaway, the battery may be damaged or an abnormal chemical reaction may occur inside the battery, resulting in electrolyte leakage or production of gases. If the battery needs to exhaust flammable gas, safe emission measures must be taken to prevent fire and device corrosion.
- Do not use damaged batteries, and ensure that the installation site must be well ventilated.

 **DANGER!**

- Exposure to sunlight can result in the generation of high DC voltage by PV modules, which can lead to electric shock causing severe injuries or even death.
- Never touch the positive or negative poles of the PV connecting device, and avoid touching both poles simultaneously.
- Do not ground the positive or negative poles of the PV modules.
- Only qualified personnel can perform the wiring of the PV modules.

 **DANGER!**

- Only operate the inverter if it is in a technically faultless condition. Operating a faulty inverter may lead to electric shock or fire.
- Do not attempt to open the enclosure without authorization from SolaX. Unauthorized opening of the enclosure will void the warranty and can result in lethal danger or serious injury due to electric shock.
- Make sure that the inverter is reliably grounded before any operation to prevent the risk of electric shock causing lethal danger or serious injury.
- Only qualified personnel can perform the installation, wiring, maintenance of the inverter by following this document and the related regulations.

 **DANGER!**

- Please make sure that the unit is free from any damage before the electrical connection.
- Do not modify, change, or dismantle the device, do not change the power-on and power-off sequences and the installation procedure written in the document, and please properly and correctly operate it.
- Do not power on the device during installation. Otherwise, it may cause a fire, personal injury, or device damage.
- Must remove earrings, rings, bracelets, watches, and any other metal jewelry before operation, to avoid electrical shock, burns, or even death.
- During operation, special insulated tools must be used to avoid electric shock or short circuit failure. The insulated tools' voltage ratings must exceed the system voltage ratings. Please refer to "Technical Data" for system information.

 **WARNING!**

- Please prepare tools that meet the requirements before installation, and check the number of tools after installation, to avoid leaving them inside the equipment.
- Please ensure that the cabinet has been thoroughly secured before operating it. Otherwise, it may cause personal injury or equipment damage due to tilting or collapsing the cabinet.
- Please ensure that the cabinet's vents and cooling system are working properly when it is running. If the vents are blocked, it will lead to overheating, and even equipment damage or fire hazard.
- Please ensure that the cabinet's vents and cooling system are kept away from heat sources.
- Do not drill holes in the device to avoid equipment failure.
- If the circumstances that may cause personal injury or equipment failure occur, such as, fluid flowing into the equipment, stop operation and power off immediately. Otherwise, it may cause a short circuit or damage.
- Do not open the cabinet doors on a rainy or high humid day ($\geq 80\%$ humidity). If the doors have to be opened on such days, please take proper protective measures.

 **WARNING!**

- Please read the document carefully before installation, operation and maintenance.
- Must arrange fire-fighting equipment in advance according to the local laws, regulations, and standards while installing and commissioning the device.
- Please check that there is no damage to the outer packaging before and after unpacking, and in the process of storage and transportation. The battery shall be correctly placed or stacked in accordance with the requirements stipulated on the labels to prevent damaging or scrapping the battery resulting from crushing or falling.
- Must tighten screws securing cables and on the copper bars according to the torque information specified in the document, and check whether they are tightened periodically. For instance, whether there is any rust, corrosion, or any other foreign object on it, and then clean it up if any. Because the loose screw connections may result in excessive voltage drops and large currents, leading to generating a lot of heat and burning the battery.
- The battery should be charged in time after discharge, to prevent battery damage due to overdischarge. If a battery pack is stored for a long time, please periodically recharge it to protect it from damage according to the storage requirements specified in the document.
- Please charge the battery within the specific temperature range because the low temperature may result in a short circuit. Hence, do not charge it when the temperature is below the low limit of the operating temperature.
- Do not use the battery when you find a bulge, or dents on the battery housing, and contact the installer or professional maintenance personnel to dismantle and replace it. The damaged battery must be kept away from other devices and flammable and explosive articles, and do not contact it except for professionals.
- Before operation, ensure that there are no irritating or burning smells around the battery.
- Do not weld or grind near a battery. Because electric sparks or arcs may cause fires.
- Do not step, lead, stand, or set on the battery.

 **WARNING!**

- Overvoltage protection with surge arresters should be provided when the PV system is installed. The grid connected inverter is fitted with SPDs on both PV input side and MAINS side.
- Please consult professionals before installing SPDs.
- Make sure that the input DC voltage does not exceed the maximum DC input voltage specified for the inverter. Overvoltage can cause irreversible damage to the inverter, and such damage is not covered by the warranty.
- PV modules should have an IEC61730 class A rating.

 WARNING!

- Operators must wear PPE while installation and maintenance of the device.
- During operation, avoid touching any parts of the inverter other than the DC switch and LCD panel.
- Never connect or disconnect the AC and DC connector while the inverter is running.
- Prior to conducting any maintenance, turn off the AC and DC power and disconnect them from the inverter. Wait for 15 minutes to fully discharge the energy.
- Avoid touching the inverter while it is running, as it becomes hot during operation and may cause personal injuries.

 WARNING!

- Please wear PPE, such as, protective clothing, insulating shoes, goggles, safety helmets, insulating gloves, etc., when conducting electrical wiring.
- Do not touch the power supply equipment directly, or through conductors or damp objects.
- Do not touch the parts of the equipment of which warning signs are attached, to avoid personal injury or device damage.

 CAUTION!

- Do not use a straight ladder. When electrical work is involved, a wooden ladder or an insulated ladder shall be used.
- The equipment shall not be used to provide a backup power source in the following circumstances:
 - a. Equipment related to life;
 - b. Sensitive precision instruments;
 - c. Home appliances will be faulty in the case of a power failure during operation.

 CAUTION!

- Make sure that children are supervised to prevent them from playing with the inverter.
- Pay attention to the weight of the inverter and handle it properly to avoid personal injuries.

 CAUTION!

- Do not power on the device until it has been installed and confirmed by professionals.
- In the event of a fire, evacuate immediately and call the local fire services.

NOTICE!

- The signs and messages on the labels and nameplates attached to the device need to be visible and clear.

NOTICE!

Transportation requirements for battery:

- Relevant qualifications for the transport of dangerous goods must be obtained by the forwarding agent engaged in such businesses, and they must strictly abide by the local regulations for the transport of dangerous goods.
- Please check the battery before transportation. If a battery leaks, smells, or is damaged, do refuse to transport it.
- Please handle gently in the process of loading and unloading, transportation, and moving a battery to prevent bumping, and take effective moisture-proof measures to prevent personal injuries and battery damage.
- Unless otherwise specified, do not transport the batteries, which are classified as dangerous goods, together with food, medicine, or other additives on the same means of transport.

If the battery leaks electrolyte or any other chemical materials, the electrolyte leakage can lead to toxic gases. Therefore, do not contact with them at all times. In case of accidentally coming into contact with them, please do as follows:

- In case of inhalation: Leave the contaminated area immediately, and seek medical attention at once;
- In case of contact with eyes: Rinse eyes with running water for at least 15 minutes, and seek medical attention;
- In case of contact with skin: Wash the contact area thoroughly with soap, and seek medical attention;
- In case of ingestion: Induce vomiting, and seek medical attention.

NOTICE!

If a fire breaks out where the battery is installed, please do as follows:

- In case a battery is charging when the fire breaks out, provided it is safe to do so, press the emergency stop button and unplug the power cable;
- In case a battery is not on fire yet, use a water-based fire extinguisher or a carbon dioxide extinguisher to extinguish the fire;
- In case a battery catches fire, do not try to put it out, and evacuate immediately;
- A battery may catch fire when it is heated above 150°F/60°C. If the battery catches fire, please evacuate immediately since it will generate noxious and poisonous gases.

Recovery of damaged or wasted battery:

- Dispose of the damaged or wasted batteries according to local laws and regulations instead of placing them in the household trash or curbside recycling bins. Otherwise, it may cause environmental pollution or explosions.
- Ensure that the damaged or wasted batteries are not exposed to the following situations: high temperatures, high humidity, direct sunlight, corrosive environments.
- Contact a battery recycling company to scrap the battery, which leaks electrolytes, or is damaged or expired.
- Please take protective steps to prevent battery short circuits before moving batteries.
- Please keep away from flammable material storage areas, residential areas, and other population centers when transporting and storing the damaged battery.

NOTICE!

- Only connect the inverter to the grid with the permission of the local utility grid company.

NOTICE!

- The inverter has an integrated Residual Current Monitoring Unit (RCMU). If an external Residual Current Device (RCD) is required by local regulations, verify the type of RCD required. It is recommended to use a Type-A RCD with a rating of 300 mA unless a lower value is required by the specific local electric codes. When required by local regulations, the use of an RCD type B is permitted.
- Keep all product labels and the nameplate on the inverter clearly visible and well-maintained.

NOTICE!

- Please operate according to the safety code for power station.
- Before installation, it is necessary to set up temporary safety fences or warning lines and hang warning signs in the operation area, to prohibit non-staff from entering here.
- Please make sure that the equipment and its associated switches are off before connecting and disconnecting power cables.
- Please check whether the protective housing and insulating sleeve for an electrical component have been installed correctly after finishing installation, to avoid electric shock.
- Must turn off the output switch of the power supply equipment when maintaining its electrical terminal device and power distribution device.
- If the device is required to be powered off during troubleshooting and diagnosis, please do as the following procedure: power off > electricity testing > connecting grounding cable > hanging warning signs and setting up guardrails.
- Must hang up "Do Not Switch On" warning signs on the relevant switches or circuit breakers before completing maintenance, to prevent power connection. Do not switch on before the fault is solved.
- Do not use water, alcohol, oil, or other solvents when cleaning electrical components inside and outside the device.

NOTICE!

Grounding Requirements:

- The device's grounding impedance shall meet the requirements of local electrical safety standards.
- The equipment shall be permanently connected to a grounding wire within the building's electrical system. Please check whether the device is reliably grounded before operation. The grounding cable should be removed last while dismantling and maintaining the device.
- Do not start the device if it is not fitted with a grounding conductor.
- All acts against the grounding conductor are prohibited.
- If the device is equipped with a three-pronged socket, make sure that the ground prong is reliably grounded.
- For the device that may generate large contact currents, please make sure that the grounding terminal on the housing has been grounded before powering on, to avoid electric shock.

NOTICE!

Cable Requirements:

- When deciding the wire diameter, and connecting or wiring cables, follow the local laws, regulations, and codes to ensure safety.
- When external conditions (e.g., placement method, ambient temperature, etc.) change, the cable type must be verified according to IEC-60364-5-52 or local laws, regulations and standards. For instance, whether the cable's current-carrying capacity meets the requirements.
- Before connecting power cables, please make sure that the cable labels are correctly labelled and the cable terminals are well insulated.
- Do not loop and twist cables while conducting electrical wiring. If the length of the power cable is not enough, please replace it instead of joining or welding. Ensure that all the cables of the correct type and size are fully connected and well insulated, and the edges of cable slots and crossing holes are smooth.
- It is recommended to bundle similar cables with cable ties, to ensure that the inside of the device is neat and tidy and to avoid cable jacket damage.
- Please use fireproof mud to seal the threading openings immediately after finishing wiring, to avoid the entry of water vapour or small animals.
- Cables should be kept away from heaters or other heat sources, because a high temperature environment may result in aging and damage to cable insulation.

Preparation before Installation

Packing List

- Battery cabinet

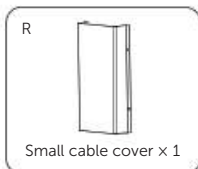
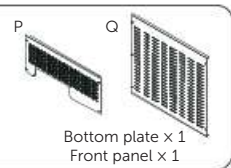
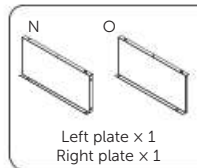
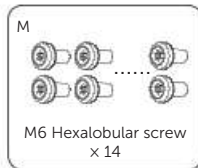
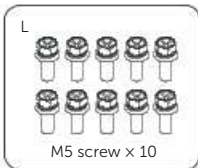
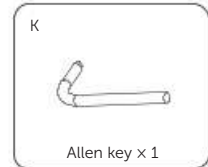
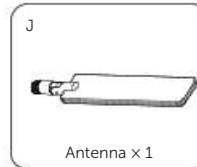
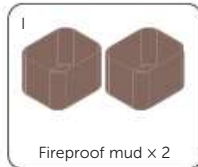
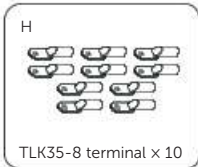
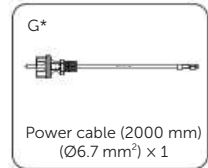
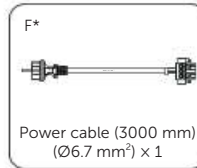
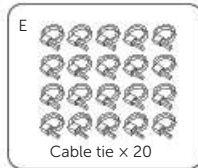
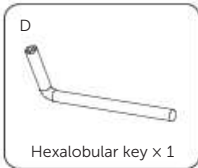
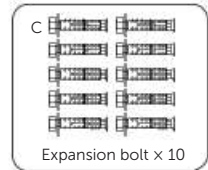
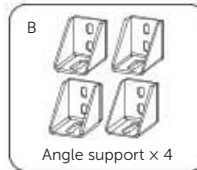
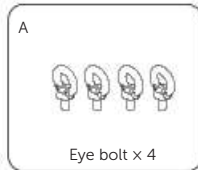
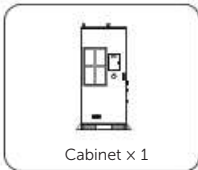

NOTICE!

- The mark "*" indicates that if one of the cables connecting the high-voltage box AC input and AC power is damaged, the power cable (3000 mm) can be used as a replacement cable to connect to the AC input and the power cable (2000 mm) can be used as a replacement cable to connect to the AC power.

• Accessory kit for capacity expansion (optional)

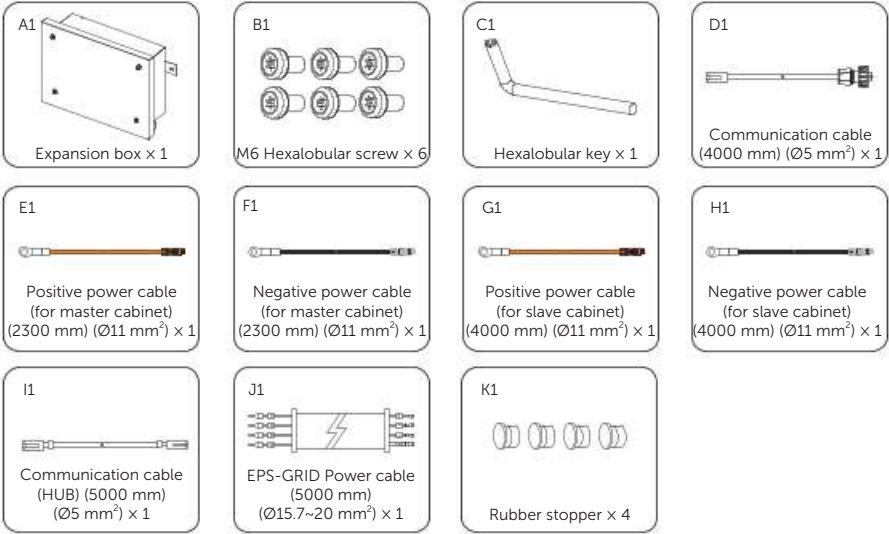

NOTICE!

- When the system needs capacity expansion, the accessory kit for capacity expansion is standard.
- For specific capacity expansion procedures, please refer to the User Manual.
- The cable diameter in the above tables refers to the outer diameter.

• Inverter



NOTICE!

- Refer to the actual delivery for the optional accessories.
- The mark "*" indicates that the positive and negative PV connector & pin contact is 10 pairs for X3-AELIO-50K, 12 pairs for X3-AELIO-60K, and the positive and negative dustproof buckles is 10 pcs for X3-AELIO-50K, 12 pcs for X3-AELIO-60K.

Installation Carrier

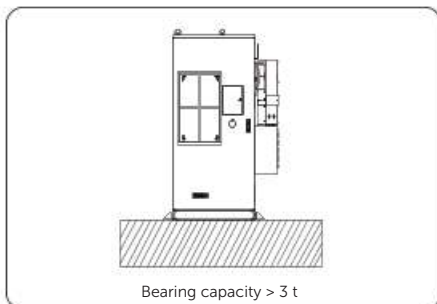

Dimension



Installation Foundation

- Plan a: Concrete foundation

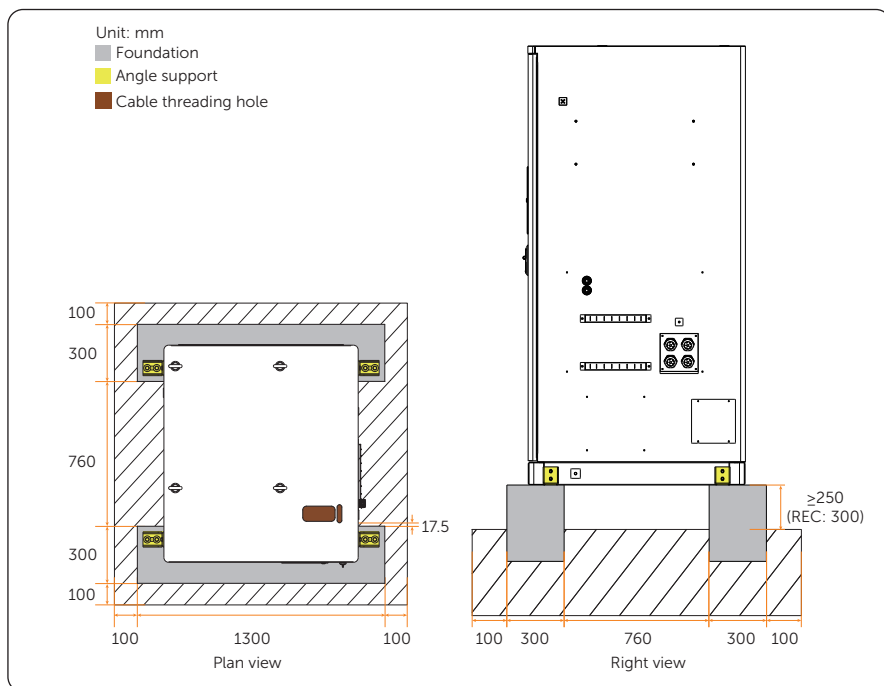
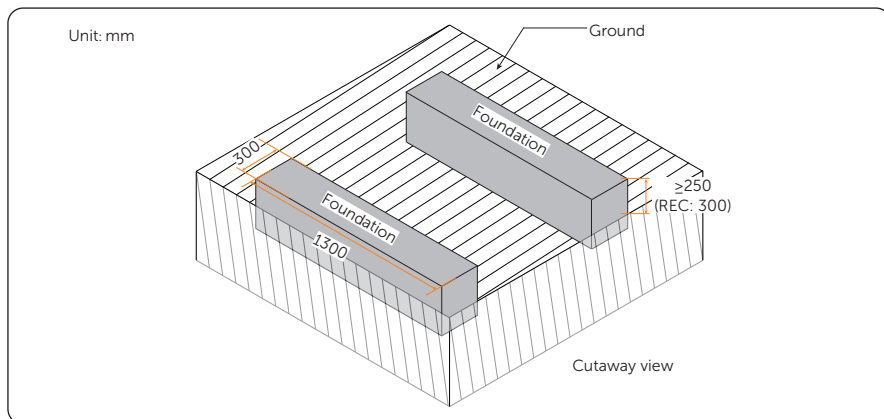

- Plan b: Steel foundation

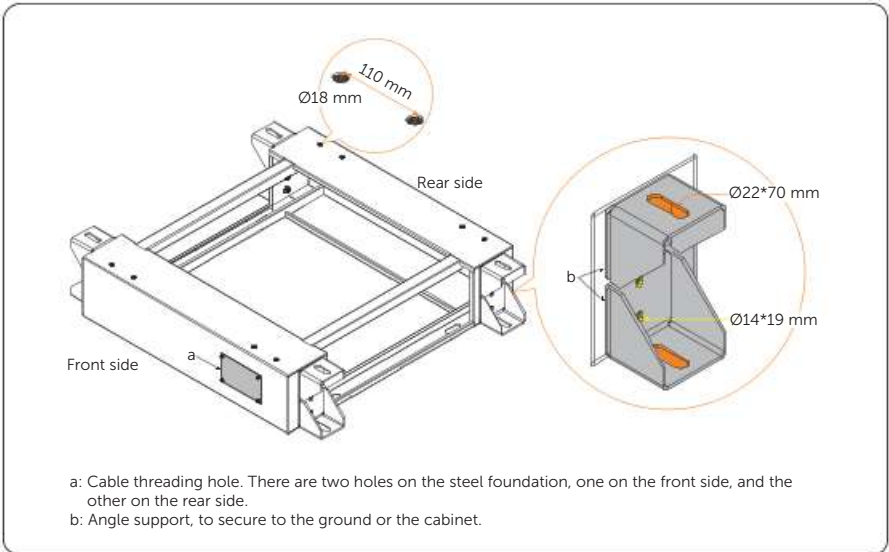
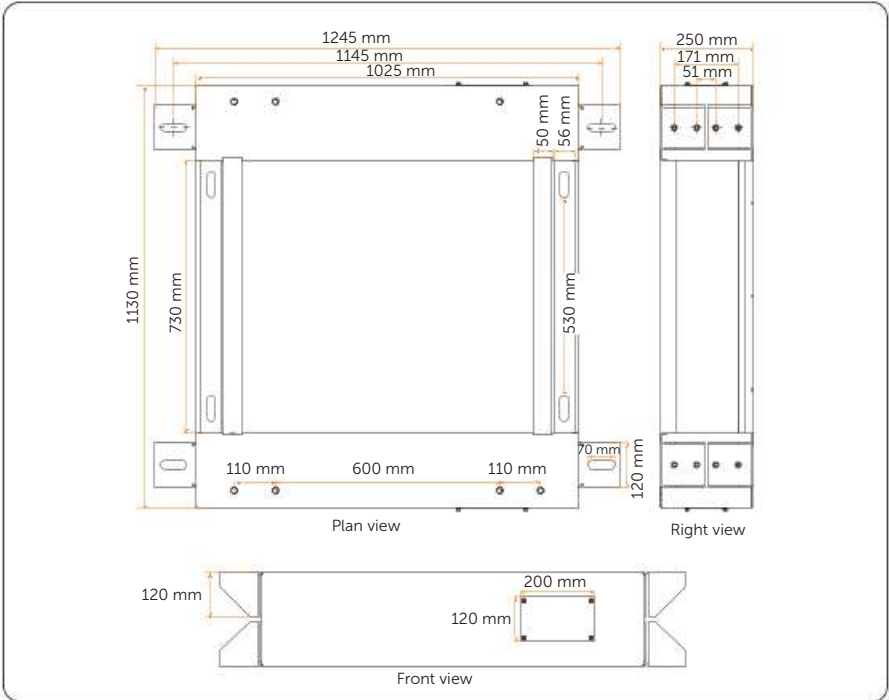

Unit: mm

■ Foundation

■ Angle support

■ Cable threading hole

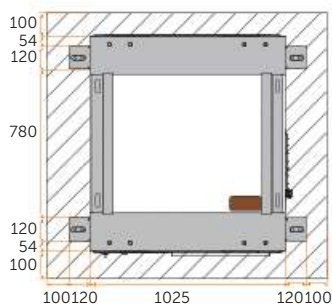

Upward view

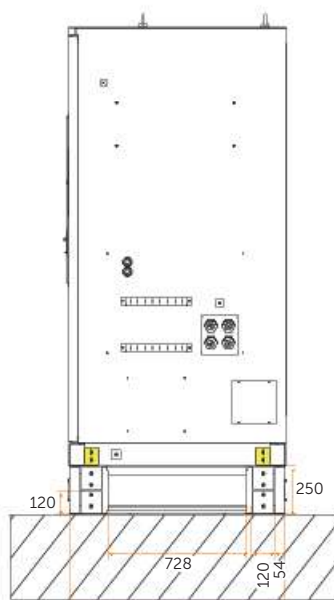

Right view

Note!

After completing construction of the steel foundation, please strictly comply with the following steps:

1. Install the bottom angle support first to secure the foundation to the ground;
2. Install the top angle support;
3. Finally, install the cabinet onto the steel foundation.

Installation Space

Single system
Unit: mm

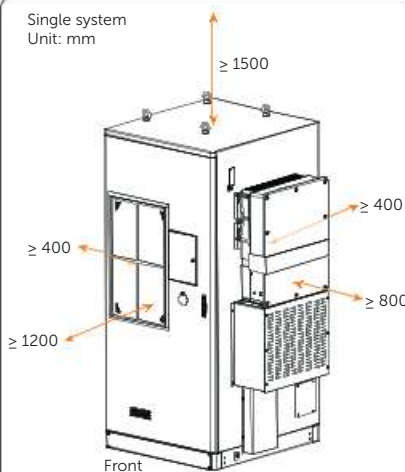

Front

Capacity expansion system
Unit: mm

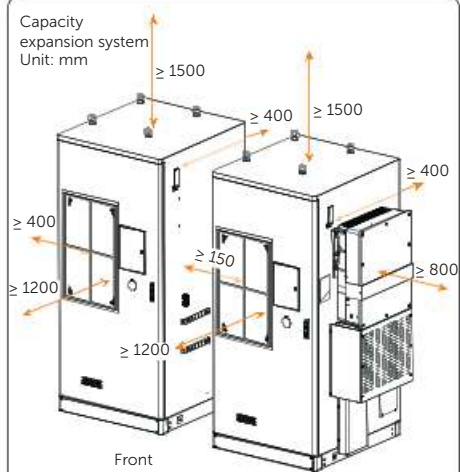

Front

Mechanical Installation

Handling

- Plan a: Hoisting

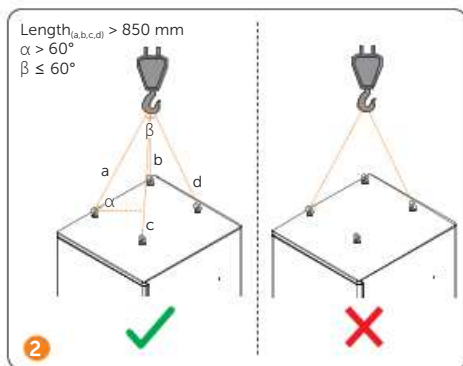
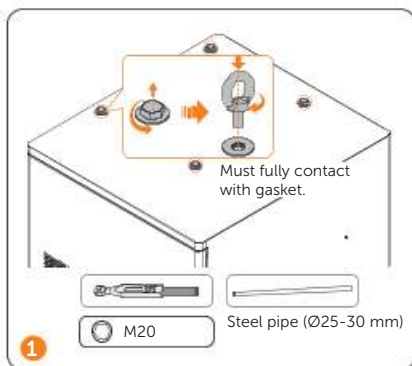

- Plan b: Forklift

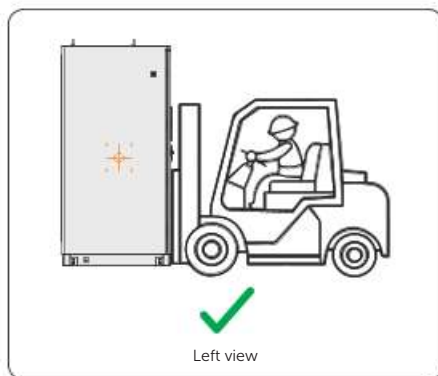
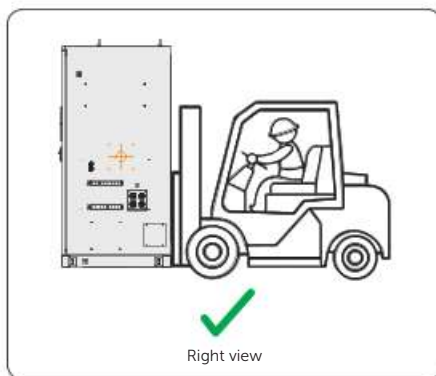

Installation Procedure for Angle Support and Cover

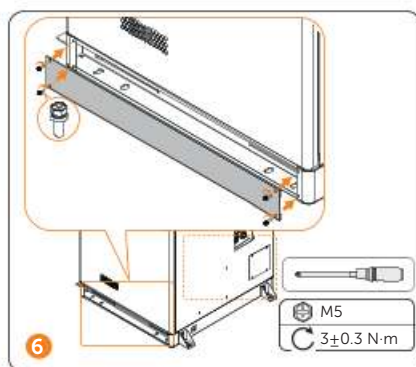
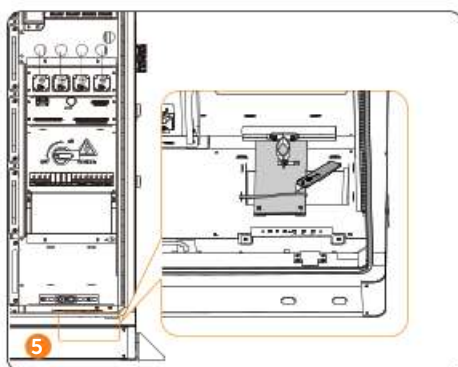
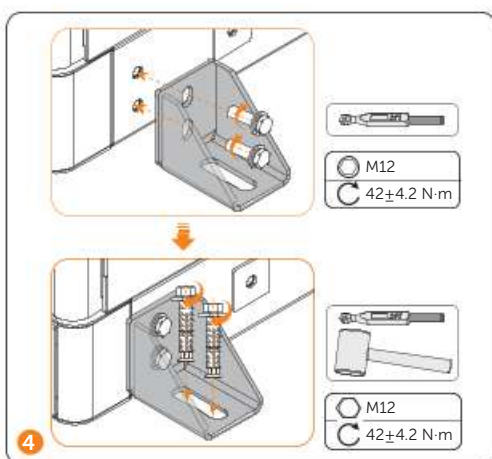
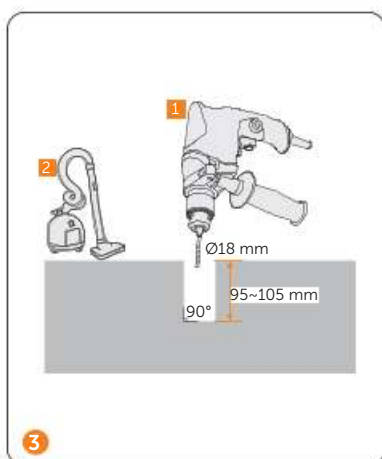
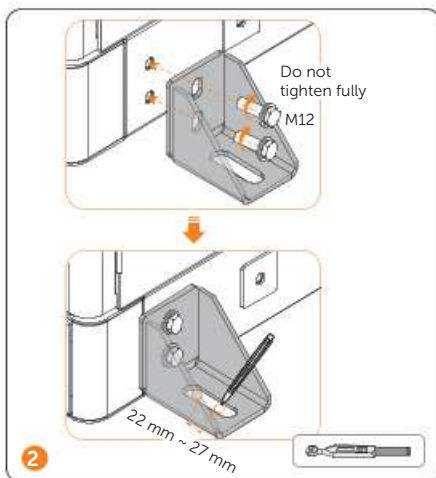
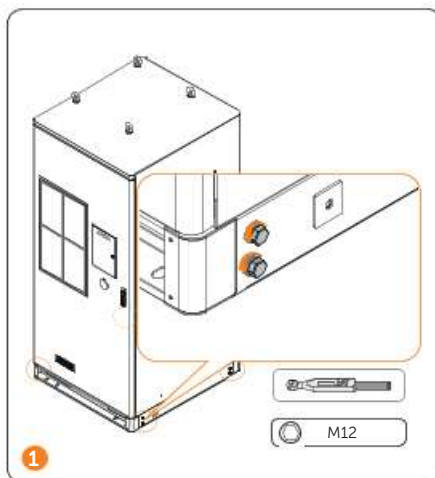

Installation of Inverter

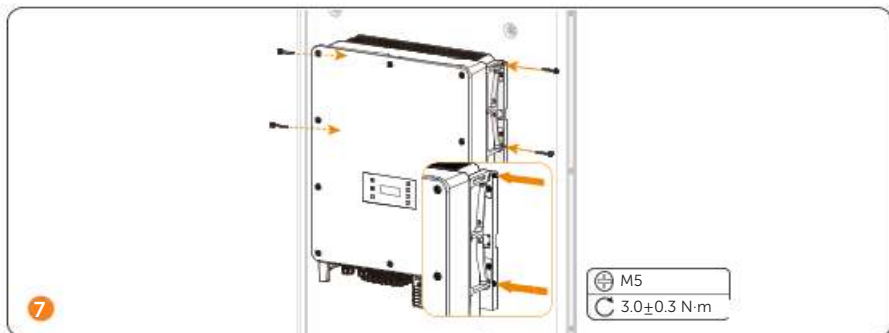
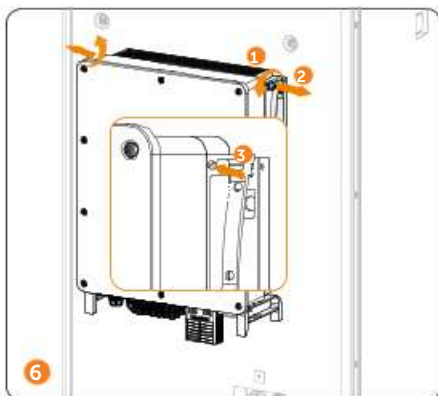
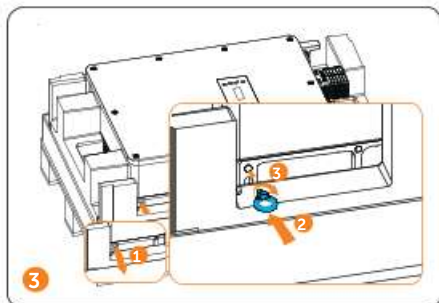
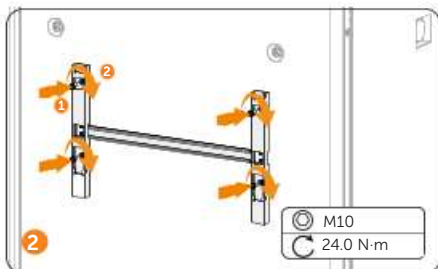
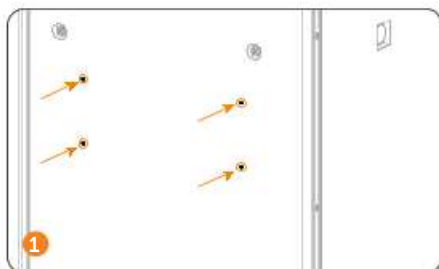

Installation of Antenna

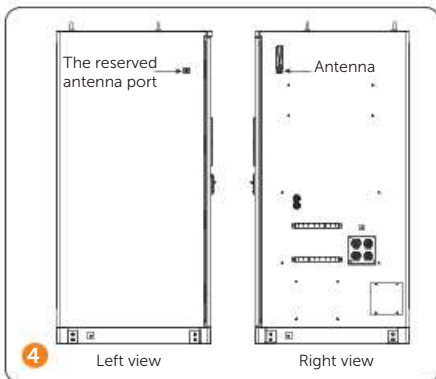
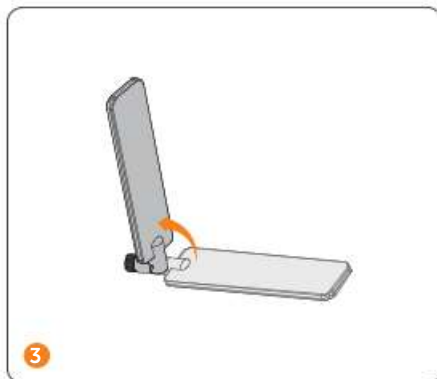
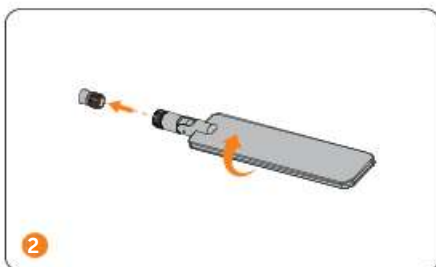
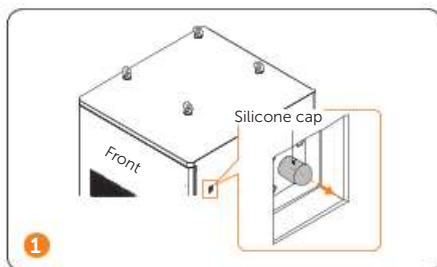

NOTICE!

- The user can decide whether the reserved port connects an antenna based on the actual situation.
- Regarding the other antenna port (the right one), the antenna is delivered with the accessories kit.
- The antenna shall be installed after finishing installation of the inverter.

Removing Covers of Smoke Detector and Temperature Sensor

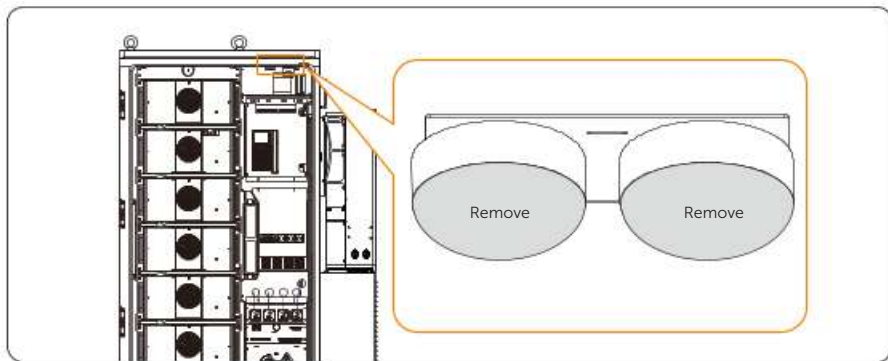

Electrical Connection

System Diagram

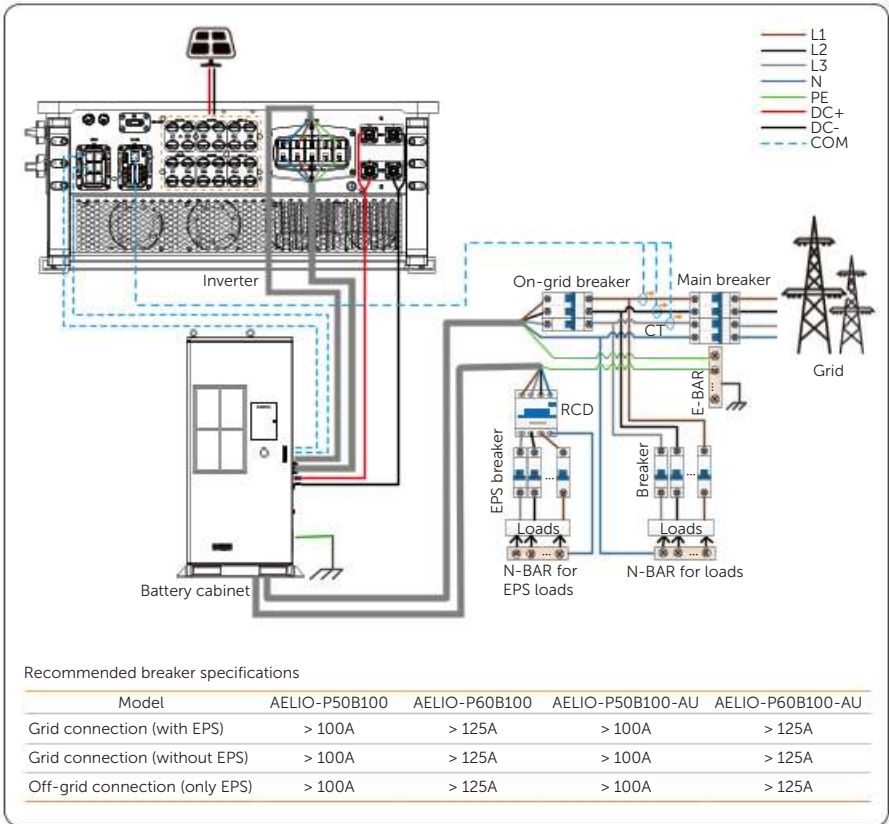

Cabinet Grounding

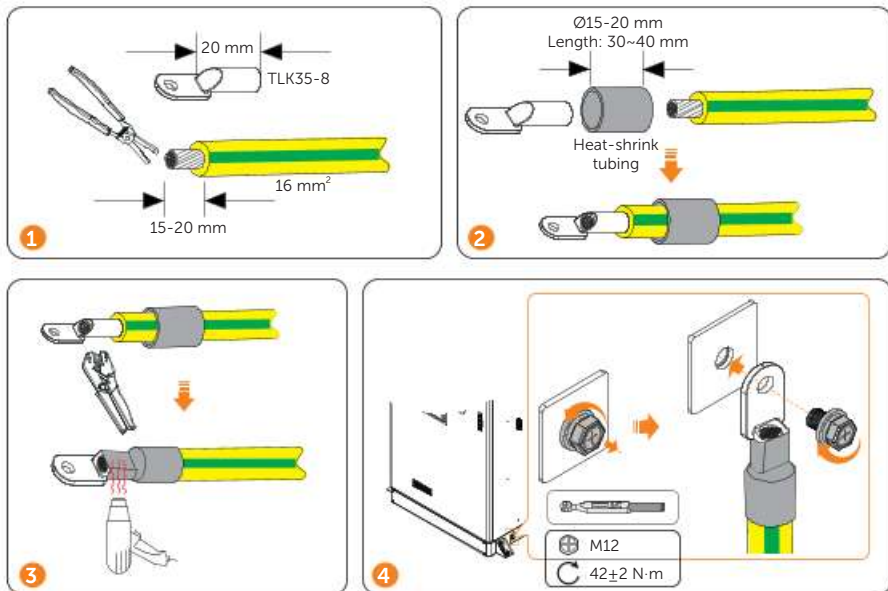

Prefabricated Inverter Cables in Battery Cabinet

NOTICE!

- The cables connecting to the inverter, such as Grid cable, EPS cable, battery cables, COM1 (EMS and BMS) communication cables are prefabricated in the cabinet side.

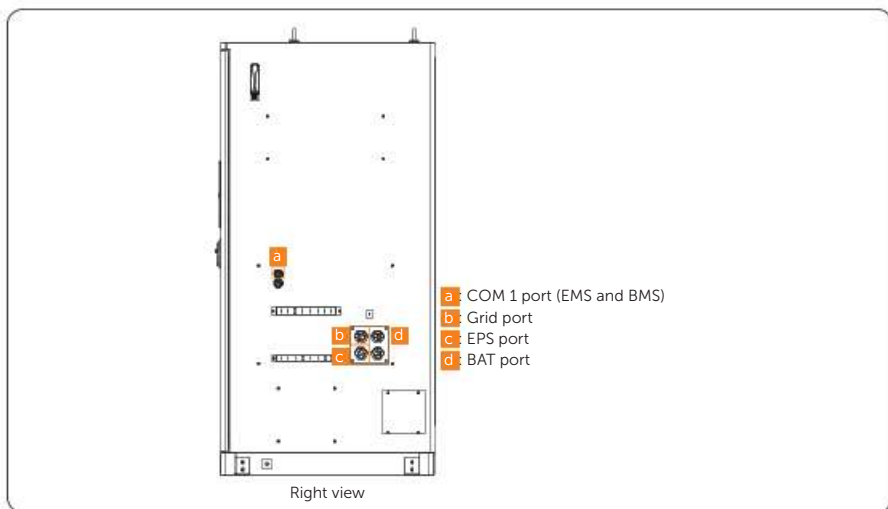

Inverter AC Side Connection

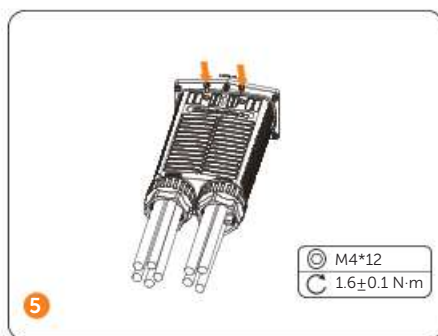
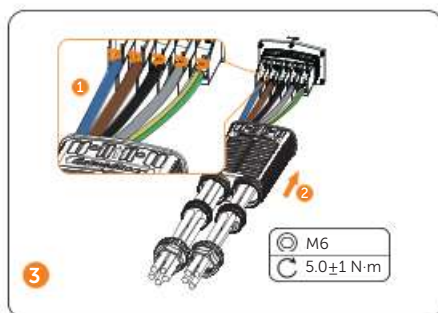
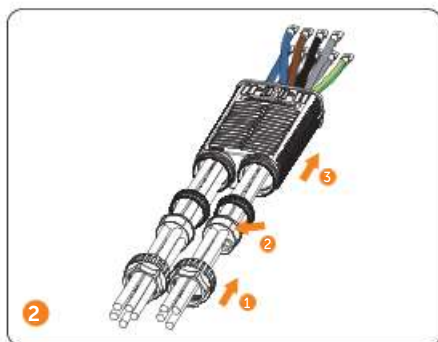
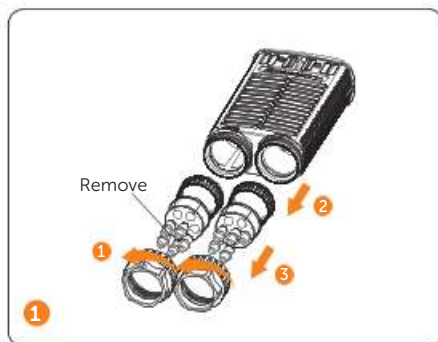

Inverter PV Connection

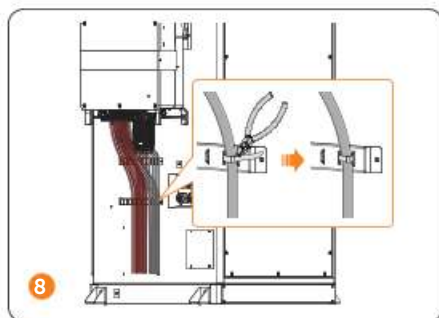
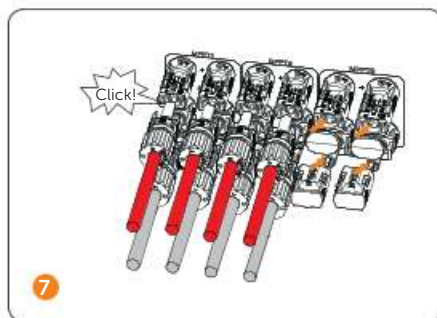
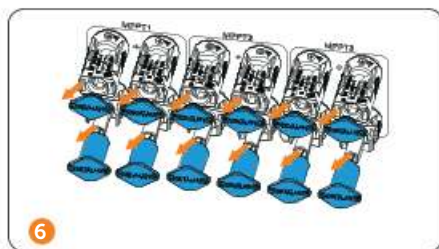
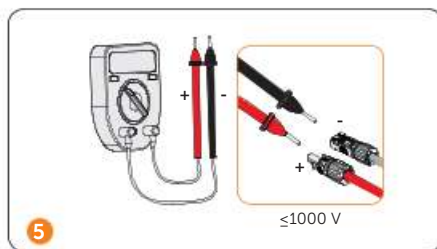
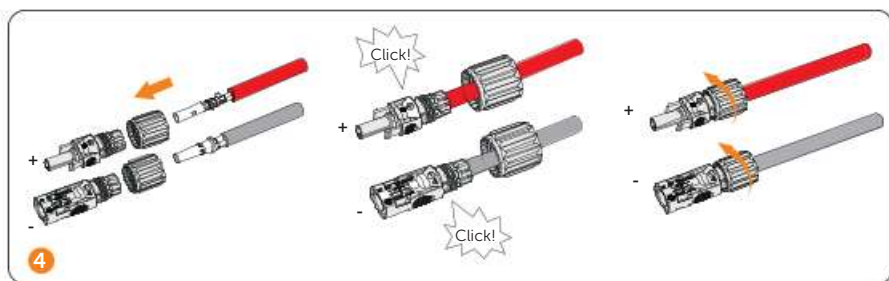
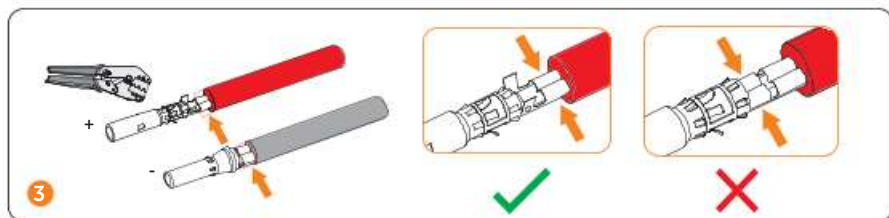
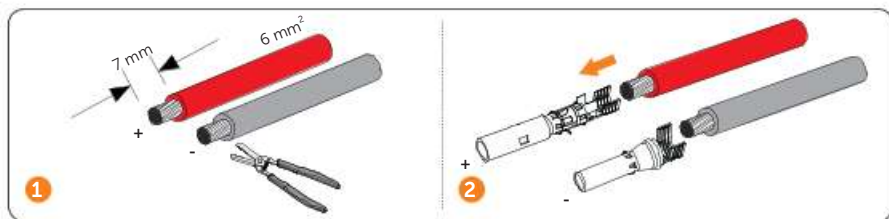

Battery Connection

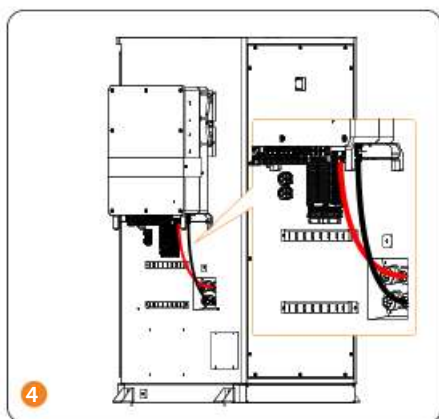
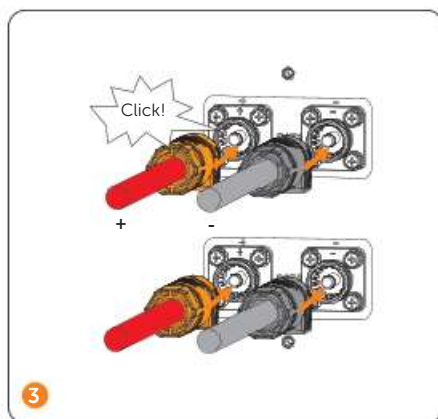
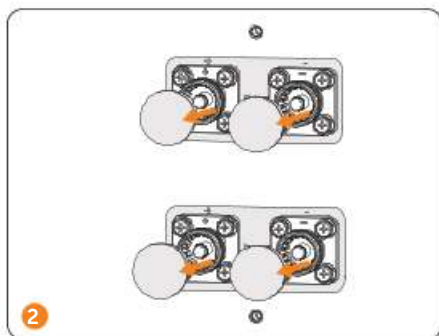
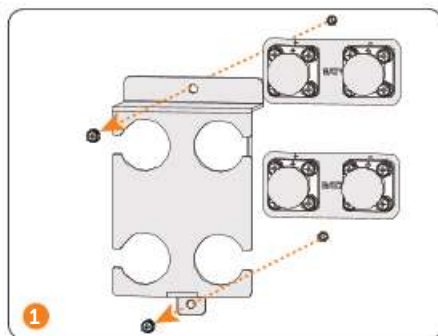

Inverter Communication Connection

Pin assignment of BMS, DRM, meter/CT and DIO

Please connect the EMS communication cable of the cabinet to PARALLEL 1 of COM1, and connect the BMS communication cable of the cabinet to BMS 1 of COM1

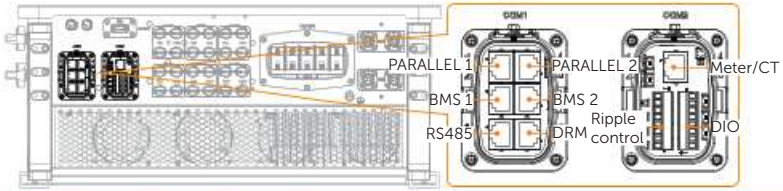

Assignment	Pin 1	Pin 2	Pin 3	Pin 4	Pin 5	Pin 6	Pin 7	Pin 8
BMS1	BAT_TEMP	GND_COM	GND_COM	BMS1_CANH	BMS1_CANL	BAT_WAKEUP_POWER	BMS1_485A	BMS1_485B
BMS2	BAT_TEMP	GND_COM	GND_COM	BMS2_CANH	BMS2_CANL	BAT_WAKEUP_POWER	BMS2_485A	BMS2_485B
DRM	DRM1/5	DRM2/6	DRM3/7	DRM4/8	+3.3V_COM	COM/DRM0	GND_COM	GND_COM
Meter/CT	CT_R1_CON	CT_S1_CON	CT_T1_CON	METER_485A	METER_485B	CT_T2_CON	CT_S2_CON	CT_R2_CON
DIO	DO_1	DO_2	DI_1+	DI_1-	DI_2+	DI_2-	GND_COM	EPSBOX_RELAY_VCC

*For pin assignment of other communication ports, refer to the user manual.

Wiring diagram of connecting a direct-connected meter

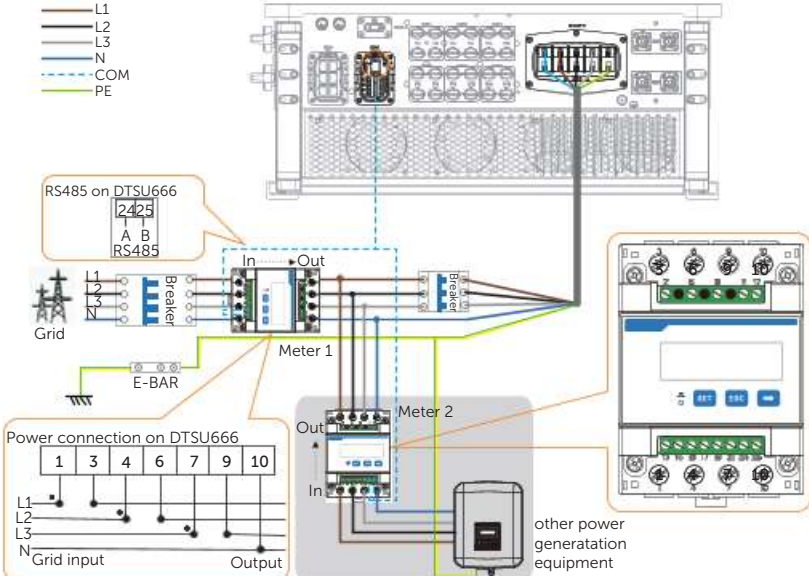

Wiring diagram of connecting a batch of CTs

- L1
- L2
- L3
- N
- COM
- PE

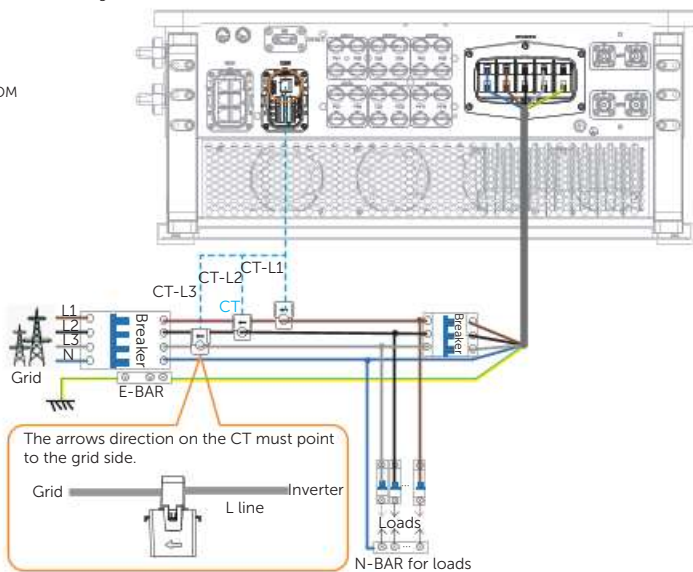

Wiring diagram of connecting a CT-connected meter

- L1
- L2
- L3
- N
- COM
- PE

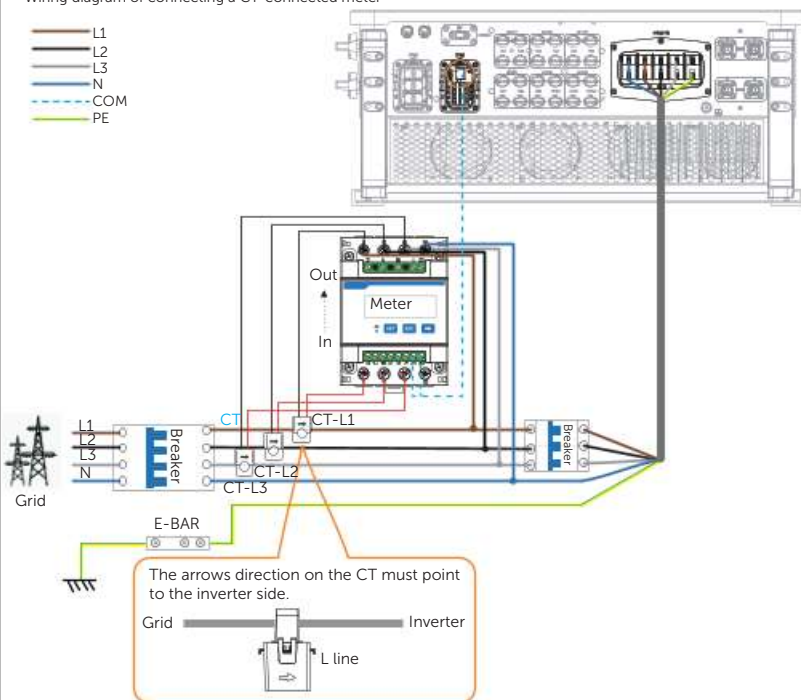

* Refer to user manual for other communication connections.

* Connect the cables according to the actual function requirements.

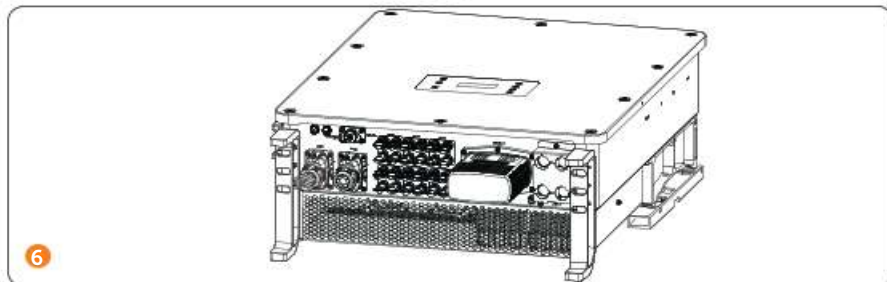
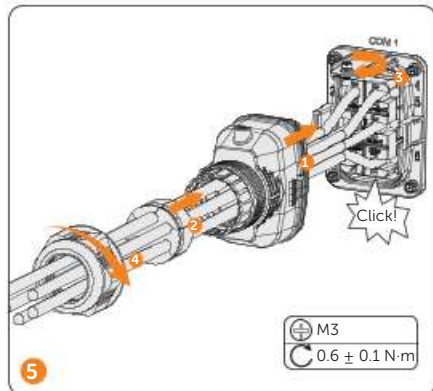
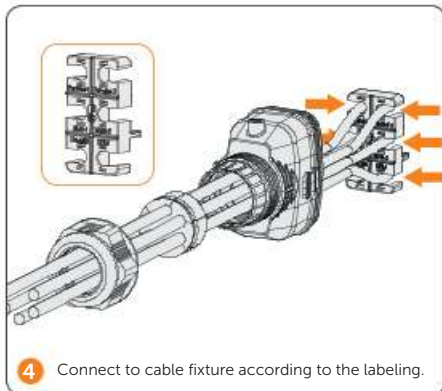
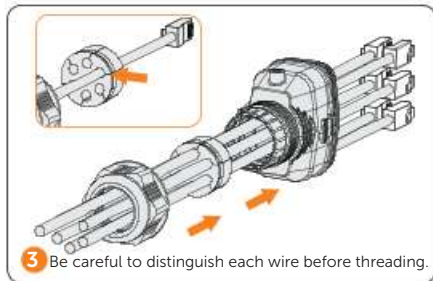
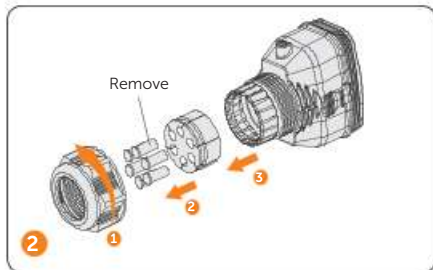
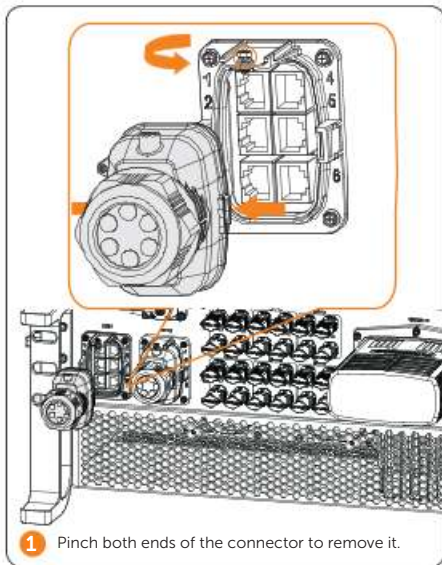

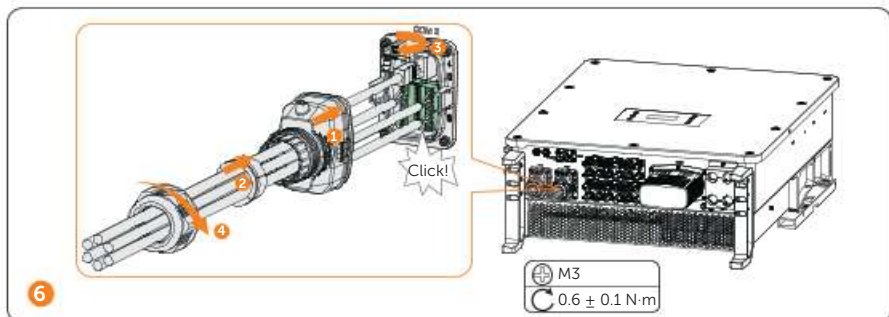
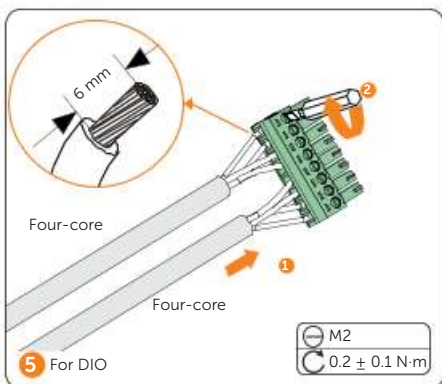
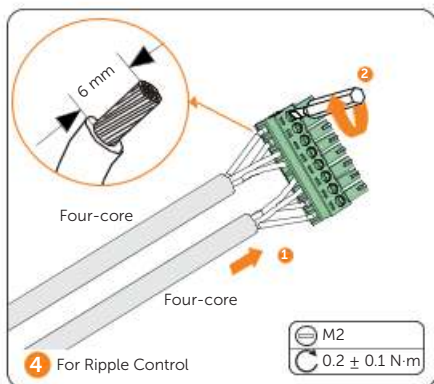
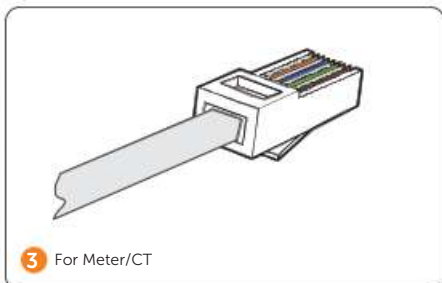
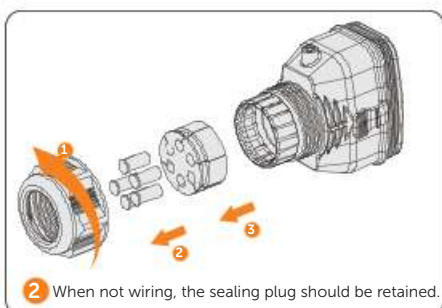
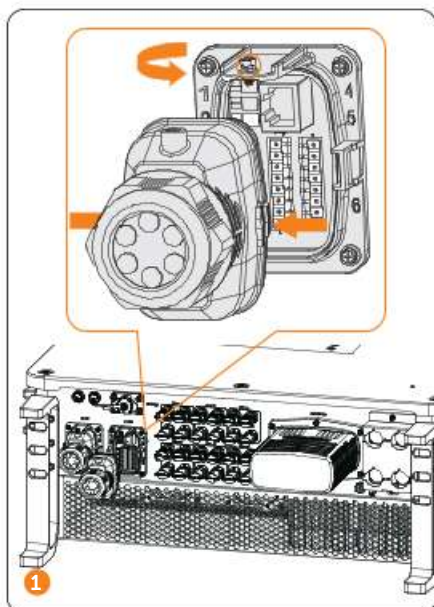

Making Grid and EPS Cables

1 The figures in this section take the Grid cable for example.

No.	Cable	Cross-sectional area	Strip length
A	Five-core cable	/	350~450 mm
B	L1/L2/L3/N	35 mm ²	20~30 mm
C	PE	16 mm ²	15~20 mm

No.	Cable	Cross-sectional area	Strip length
A	Four-core cable	/	350~450 mm
B	L1/L2/L3/N	35 mm ²	20~30 mm

2

No.	Cable	Heat shrink tubing Diameter	Heat shrink tubing Length	Terminal
A	L1/L2/L3/N	Ø17~25 mm	50~60 mm	TLK35-8
B	PE	Ø10~15 mm	30~40 mm	TLK16-8

No.	Cable	Heat shrink tubing Diameter	Heat shrink tubing Length	Terminal
A	L1/L2/L3/N	Ø17~25 mm	50~60 mm	TLK35-8

3 Take L1 wire for instance.

4

Opening/Closing the Cabinet Doors

Open the door

$\alpha \geq 130^\circ$

Close the door

NOTICE!

- Take out the underground electrical wiring which is buried beneath the ground.

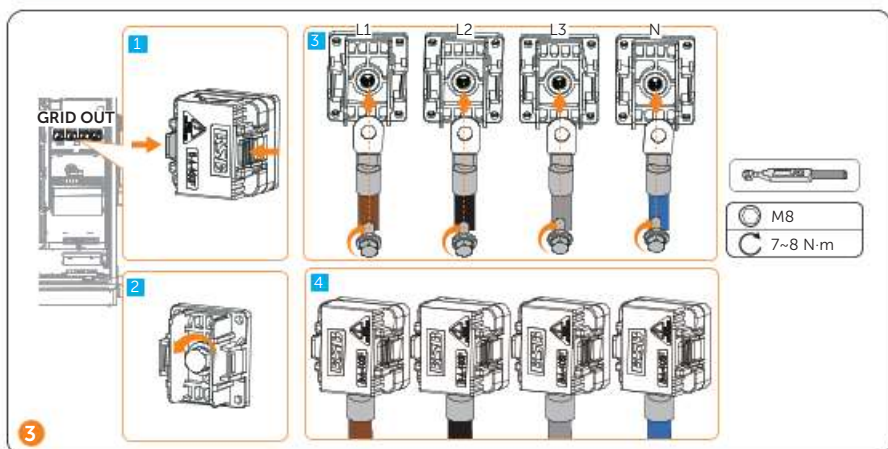
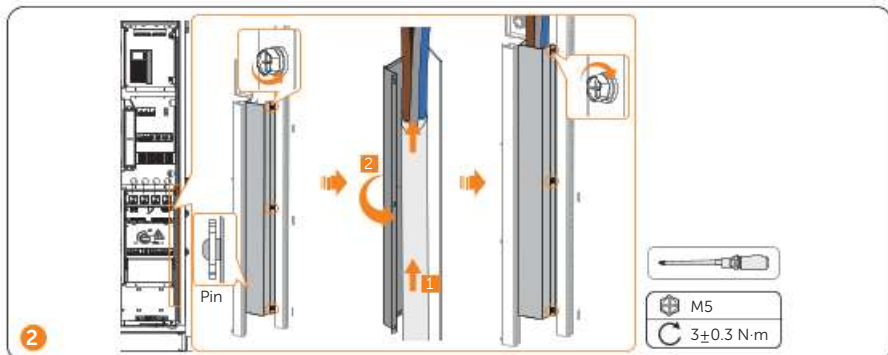
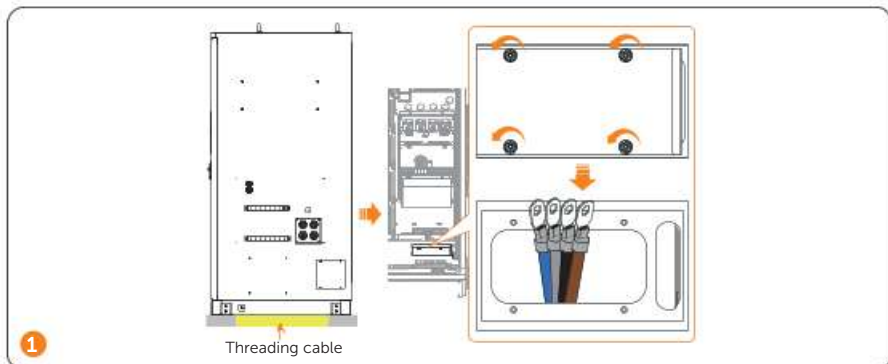

Grid Connection

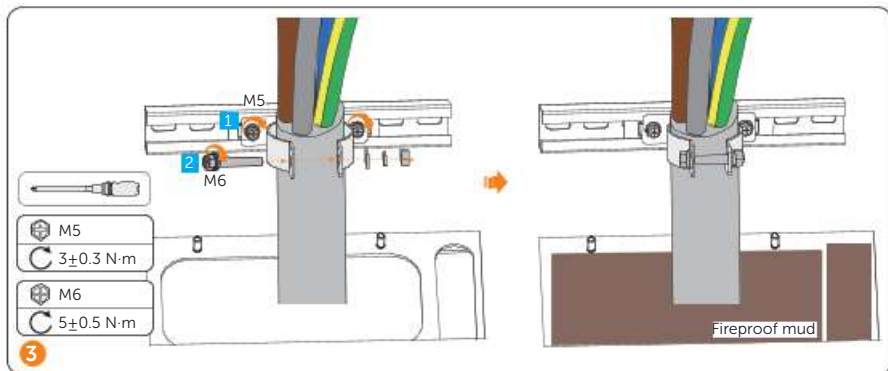
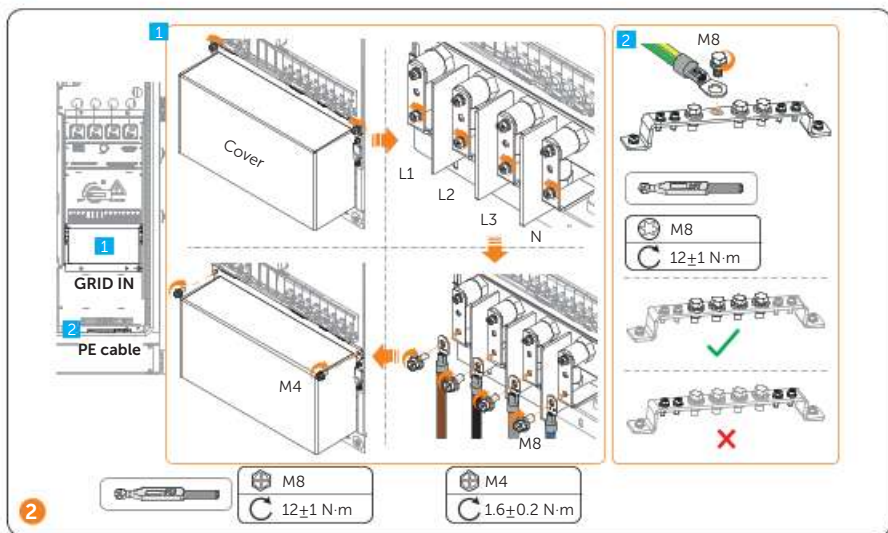
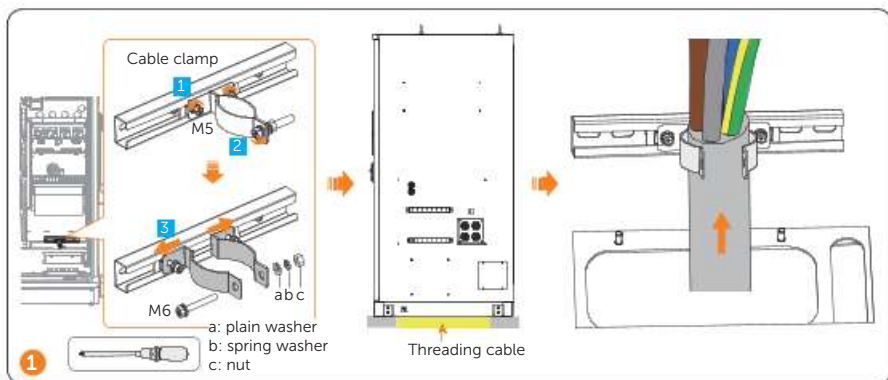

Installation of Cable Cover

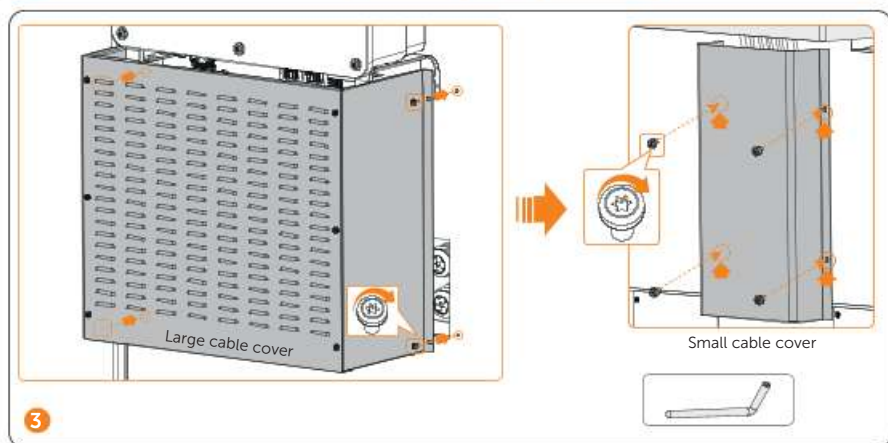
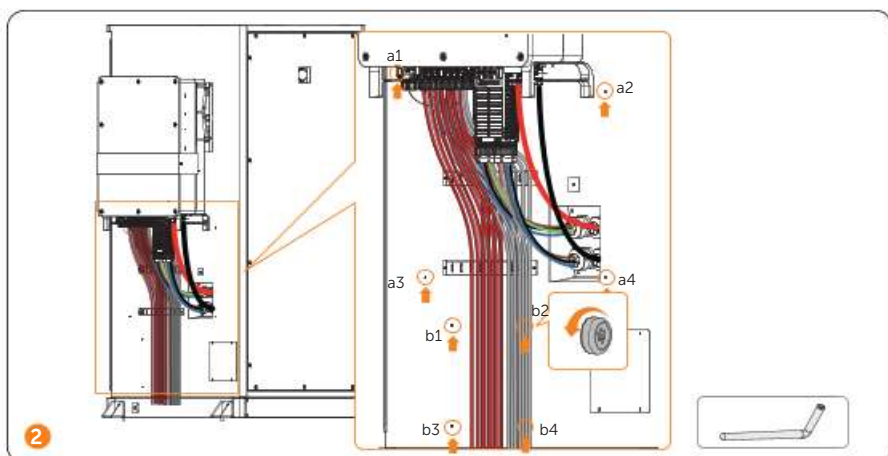
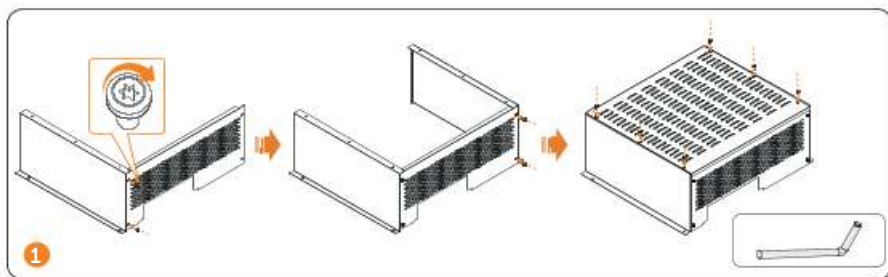

Power on and off the System

Power on: 1 > 2 1 2 > 3 > 4 > 5 1 2 > 6 > 7 > 8 > 9 1 2

Power off: 9 2 > 7 > 8 > 9 1 > 1 > 3 > 5 2 1 > 4 > 2 2 1 > 6

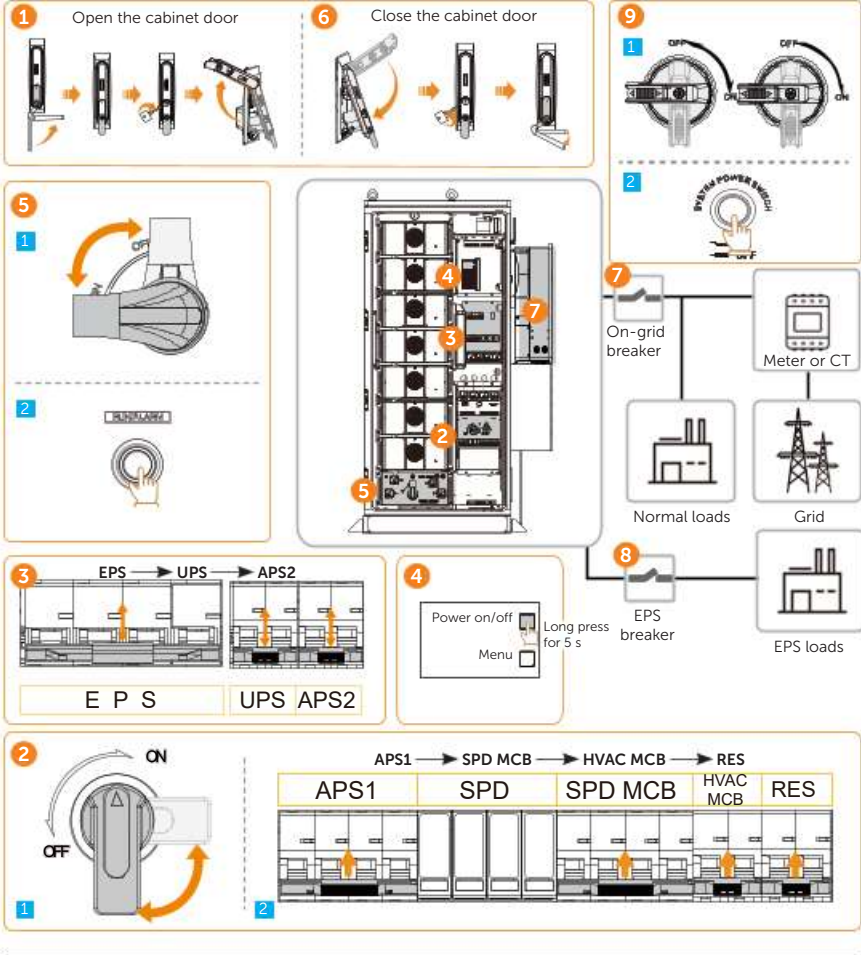

Emergency power off

WARNING!

- Do not press the emergency stop button except for emergencies.
- Some modules inside the cabinet may still have power after pressing the emergency stop button, therefore, non-professionals are not allowed to operate them.

NOTICE!

If it has been pressed, the emergency stop button must be reset before starting the equipment. The reset steps are shown as follows:

- a. Rotate the cover;
- b. Rotate the button according to the arrow direction shown on the button. Then the button will spring back to its original position.

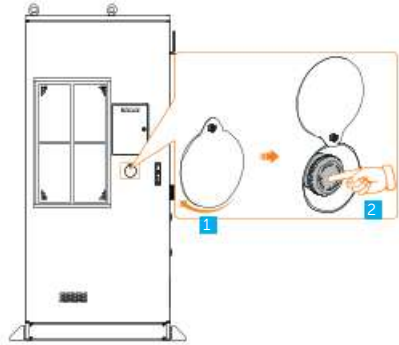

LED Indicators

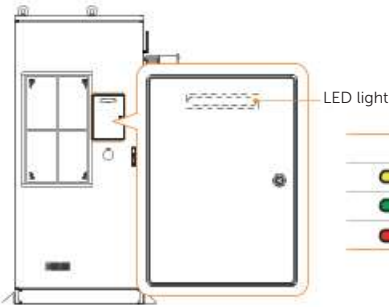

LED light	Description
	Solid yellow In standby
	Solid green In operation
	Solid red System failure

System Configuration

Inverter Configuration

1 User Settings



The initial password is 0 0 0 0 which should be changed for the consideration of account security.

- Data&Time, Language

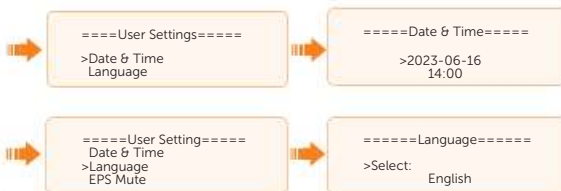

2 Advance Settings

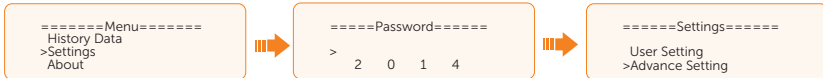

The initial password is 2014 which should be changed for the consideration of account security.

- Safety Code



Set the corresponding safety standards according to different countries

- Export Control



Set the control power to 0 for the countries with zero export control limit

- Meter / CT Setting-if CT is connected

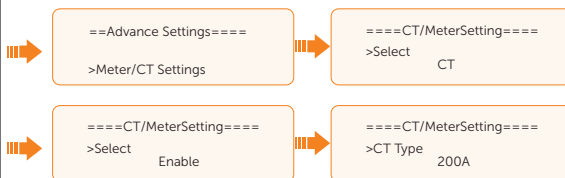

- Meter / CT Setting-if Meter is connected

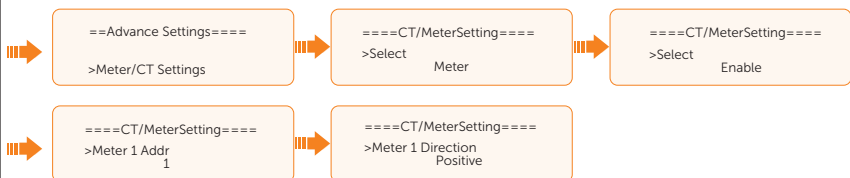

- Internal485 Settings



Set the Internal485 to EMS, check whether the baud rate is the same as EMS.

- Shut Down



The Shut Down function needs to be set for areas with NS protection devices.

Inverter Screen Cover Installation

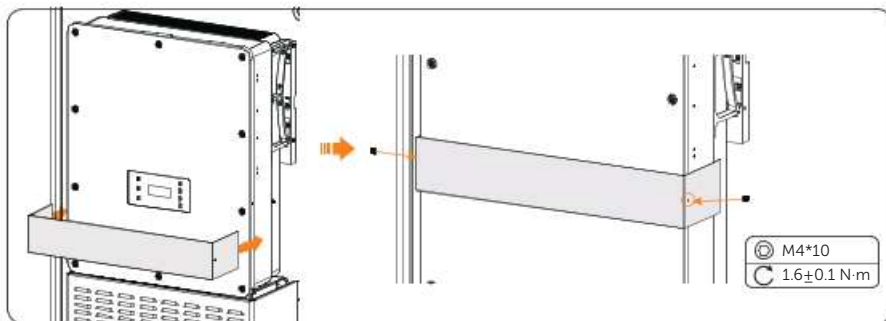

EMS Configuration

1 Unlocking screen door

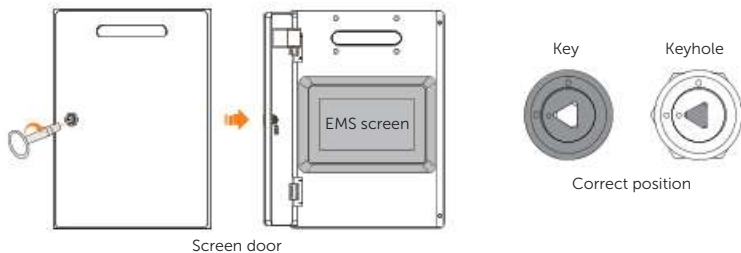

2 Log in to the screen

Username	Password	Remarks
user	123456 by default	The password can be modified on EMS1000 webpage.

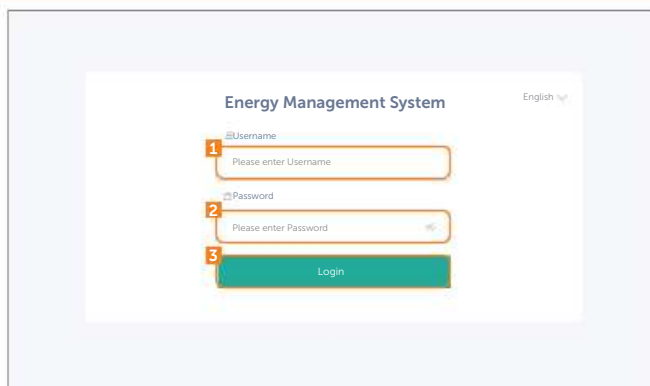

6 Set inverter parameters

Device type	COM method	COM port	Connected device qty	Address allocation
Inverter	Modbus RTU	COM 7	1	Auto

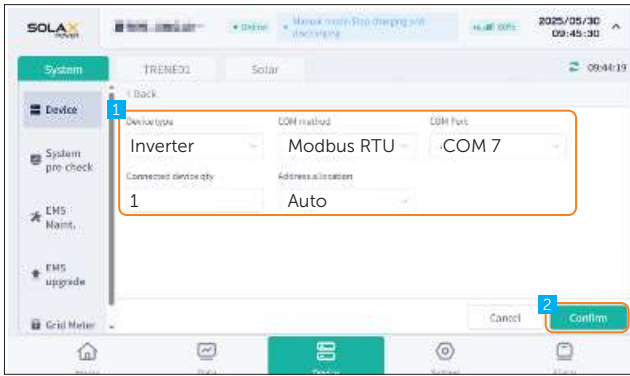

7 Pairing device

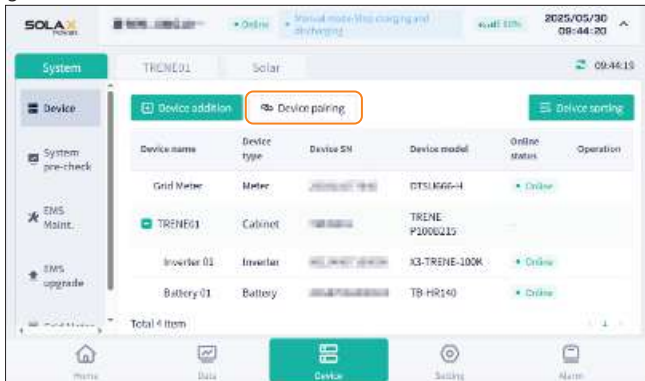

8 Save and pre-check

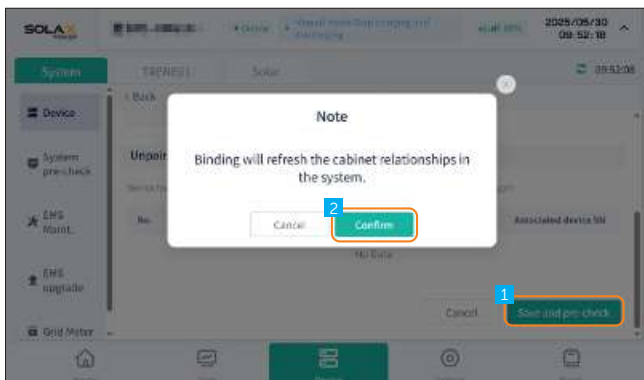

- 9 Remote settings: The initial password is 2014. For your account security, change it after the first setting.

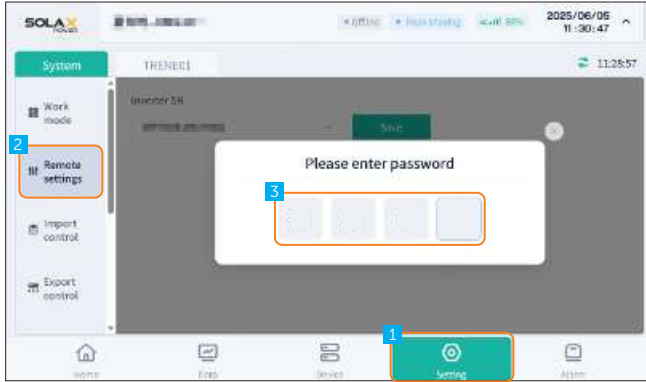

SolaXCloud Download

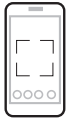

SolaXCloud

Scan the QR code to download SolaXCloud App. Follow the tutorial or online documents on the SolaXCloud App to complete the configuration.

Warranty Registration

Please visit the website: <https://www.solaxcloud.com/user-center/> to complete the warranty registration. For more detailed warranty terms, please visit SolaX official website: www.solaxpower.com.



SolaX Power Network Technology (Zhejiang) Co., Ltd.

Add.: No. 278, Shizhu Road, Chengnan Sub-district, Tonglu County,
Hangzhou, Zhejiang, China
E-mail: info@solaxpower.com