



Air Cooling Energy Storage System

AELIO-P50B200 / AELIO-P60B200

User Manual

Version 4.0

www.solaxpower.com



QR Manual in the left corner of
at www.solaxpower.com

STATEMENT

Copyright

Copyright © SolaX Power Network Technology (Zhejiang) Co., Ltd. All rights reserved.

No part of this manual may be reproduced, transmitted, transcribed, stored in a retrieval system, or translated into any language or computer language, in any form or by any means without the prior written permission of SolaX Power Network Technology (Zhejiang) Co., Ltd.

Trademarks



SOLA X and other symbol or design (brand name, logo) that distinguishes the products or services offered by SolaX has been trademark protected. Any unauthorized use of the above stated trademark may infringe the trademark right.

Notice

Please note that certain products, features, and services mentioned in this document may not be within the scope of your purchase or usage. Unless otherwise specified in the contract, the contents, information, and recommendations presented in this document are provided "as is" by SolaX. We do not provide any warranties, guarantees, or representations, whether express or implied.

The content of the documents is reviewed and updated as needed. However, occasional discrepancies may occur. SolaX retains the right to make improvements or changes in the product(s) and the program(s) described in this manual at any time without prior notice.

The images included in this document are solely for illustrative purposes and may differ based on the specific product models.

For more detailed information, kindly visit the website of SolaX Power Network Technology (Zhejiang) Co., Ltd. at www.solaxpower.com.

SolaX retains all rights for the final explanation.

About This Manual

Scope of Validity

This manual is an integral part of AELIO-P50B200 and AELIO-P60B200. It describes the transportation, storage, installation, electrical connection, commissioning, maintenance and troubleshooting of the product. Please read it carefully before operating.

AELIO-P50B200 and AELIO-P60B200 system includes a X3-AELIO series inverter and a AELIO-B200 battery cabinet.

X3-AELIO series inverter model list:

Model	X3-AELIO-50K	X3-AELIO-60K
-------	--------------	--------------

Battery cabinet model list:

Model	AELIO-B200
-------	------------

Model description

AELIO-P50B200



No.	Definition	Description
1	Product name	AELIO: Refer to the name of hybrid energy storage system.
2	Power	P50: Indicate that the rate power of the inverter is 50 kW.
3	Battery capacity	B200: Indicate that the battery capacity is 200 kWh.



Target Group

The installation, maintenance and grid connection setting can only be performed by qualified personnel who

- Are licensed and/or satisfy state and local jurisdiction regulations.
- Have good knowledge of this manual and other related documents.
- A medium-voltage operator is required to obtain any Certifications for High-voltage Electrician.

Conventions

The symbols that may be found in this manual are defined as follows.

Symbol	Description
 DANGER	Indicates a hazardous situation which, if not avoided, will result in death or serious injury.
 WARNING	Indicates a hazardous situation which, if not avoided, could result in death or serious injury.
 CAUTION!	Indicates a hazardous situation which, if not avoided, could result in minor or moderate injury.
NOTICE!	Provides tips for the optimal operation of the product.

Change History

Version 04 (2025-12-09)

1. Added ["6.5 Smoke Detector and Temperature Sensor Covers Removal"](#).
2. Upgraded the structure of the distribution box, updated relevant figures.

Version 03 (2025-11-06)

1. Packaging material changed from carton to wooden crate, updated ["3.1 Transportation"](#) and ["5.1.1 Unpacking"](#).
2. Added ["14.5 Capacity Expansion"](#).

Version 02 (2025-04-08)

Updated ["2.5 Parts Description"](#), added the description about the air conditioner working mode

Updated ["Steel foundation"](#).

Updated ["7.3 EPS Connection"](#) and ["7.4 Grid Connection"](#).

Updated AC side technical data in ["13 Technical Data"](#).

Version 01 (2024-12-30)

Updated safety regulation in ["1 Safety"](#), ["3 Transportation and Storage"](#) and ["4 Preparation before Installation"](#).

Updated AC side technical data in ["13 Technical Data"](#).

Version 00 (2024-09-09)

Initial release

Table of Contents

- 1 Safety 1
 - 1.1 General Safety 1
 - 1.2 Device Safety 2
 - 1.2.1 Cabinet Safety 2
 - 1.2.2 Battery Safety 3
 - 1.2.3 Inverter Safety 5
 - 1.2.4 Utility Grid Safety 7
 - 1.3 Electrical Safety 7
- 2 Product Overview 10
 - 2.1 System Overview 10
 - 2.2 Product Introduction 11
 - 2.3 Supported Power Grid 12
 - 2.4 Appearance and Dimension 13
 - 2.5 Parts Description 14
 - 2.6 Indicator 26
 - 2.7 Symbols 29
 - 2.8 Working Mode 30
 - 2.8.1 Self-use Mode (Priority: Loads > Battery > Grid) 30
 - 2.8.2 Feed-in Priority (Priority: Loads > Grid > Battery) 32
 - 2.8.3 Backup Mode (Priority: Loads > Battery > Grid) 33
 - 2.8.4 Peak Shaving Mode 35
 - 2.8.5 TOU Mode 36
 - 2.8.6 EPS Mode (Priority: Loads > Battery) 37
 - 2.8.7 Manual Mode 38
 - 2.8.8 Export Control Function 38
 - 2.9 Application Schemes 40
 - 2.10 Operating Principle 42
- 3 Transportation and Storage 43
 - 3.1 Transportation 43
 - 3.1.1 Battery Cabinet Transportation 43
 - 3.1.2 Inverter Transportation 46
 - 3.2 Storage 46
 - 3.2.1 Cabinet Storage 46
 - 3.2.2 Inverter Storage 48

- 4 Preparation before Installation..... 49
 - 4.1 Installation Site Selection49
 - 4.1.1 Installation Foundation Requirements..... 51
 - 4.1.2 Clearance Requirement56
 - 4.2 Tools Requirement.....57
 - 4.3 Additionally Required Materials58
- 5 Unpacking and Inspection 60
 - 5.1 Battery Cabinet Unpacking.....60
 - 5.1.1 Unpacking60
 - 5.1.2 Packing List61
 - 5.2 Inverter Unpacking.....64
 - 5.2.1 Unpacking64
 - 5.2.2 Packing List65
- 6 Mechanical Installation 67
 - 6.1 Battery Cabinet Installation Dimensions68
 - 6.2 Battery Cabinet Handling.....70
 - 6.2.1 Hoisting70
 - 6.2.2 Forklift.....73
 - 6.3 Installation Procedure for Angle Support and Cover74
 - 6.4 Antenna Installation77
 - 6.5 Smoke Detector and Temperature Sensor Covers Removal.....78
 - 6.6 Inverter Installation.....79
 - 6.6.1 Inverter Installation Dimensions80
 - 6.6.2 Installation Procedures81
- 7 Electrical Connection 85
 - 7.1 Cabinet Grounding Connection.....86
 - 7.2 Inverter Electrical Connection.....89
 - 7.2.1 Terminals of Inverter.....90
 - 7.2.2 AC Connection91
 - 7.2.3 PV Connection.....95
 - 7.2.4 Battery Power Cable Connection99
 - 7.2.5 COM 1 Communication Connection.....103
 - 7.2.6 COM 2 Communication Connection113
 - 7.3 EPS Connection.....121
 - 7.4 Grid Connection129
 - 7.5 Fireproof Mud138
 - 7.6 Installation Procedure for Cable Cover.....139

- 8 System Commissioning 141**
 - 8.1 Checking before Power-on 141
 - 8.2 Power ON 142
 - 8.3 Checking after Power-on 146
 - 8.4 Operation of Lockable DC Switch (for Australia Version Only) 147
- 9 System Configuration 150**
 - 9.1 Operation on Inverter LCD 150
 - 9.1.1 Introduction of Control Panel 150
 - 9.1.2 Introduction of Menu Interface 151
 - 9.1.3 Setting 151
 - 9.2 Inverter Screen Cover Installation 155
 - 9.3 Operation on Cabinet Screen 156
 - 9.3.1 Logging in 156
 - 9.3.2 Adding Inverter 158
 - 9.3.3 Pairing Inverter and Cabinet 160
- 10 SolaXCloud App 162**
 - 10.1 Introduction of SolaXCloud 162
 - 10.2 Operation Guide on SolaXCloud App 162
 - 10.2.1 Downloading and Installing App 162
 - 10.2.2 Operation on the SolaXCloud App 163
- 11 Troubleshooting and Maintenance 164**
 - 11.1 Power Off 164
 - 11.2 Troubleshooting 169
 - 11.2.1 Battery Cabinet Troubleshooting 169
 - 11.2.2 Inverter Troubleshooting 173
 - 11.3 Maintenance 181
 - 11.3.1 Disassembly and Clean of Air Conditioner Filter 184
- 12 Decommissioning 186**
 - 12.1 Disposing of the Wasted and Damaged Battery Pack 186
 - 12.2 Disposing of the Wasted and Damaged Inverter 186
- 13 Technical Data 187**
- 14 Appendix 189**
 - 14.1 Requirements for OT/DT Terminal 189
 - 14.2 How to Repaint the Cabinet 191
 - 14.2.1 Light Scratches & Small Areas of Stubborn Stains 191
 - 14.2.2 Deep Scratches and Large Areas of Stubborn Stains 193

14.2.3	Logo & Pattern damaged, Dents or Dings.....	196
14.3	Micro-grid Application	197
14.3.1	Introduction of Micro-grid Application.....	197
14.3.2	Wiring Connection Diagram.....	197
14.3.3	Working Modes.....	198
14.3.4	Cable Connection (Hybrid inverter).....	200
14.3.5	Cable Connection (On-grid Inverter).....	200
14.3.6	Cable Connection (Meter).....	200
14.4	CT/Meter Connection Scenarios	203
14.4.1	Connection of CT.....	203
14.4.2	Connection of Direct-connected Meter	206
14.4.3	Connection of CT-connected Meter	209
14.4.4	Connection of Two Meters	212
14.5	Capacity Expansion.....	217
14.5.1	Capacity Expansion of Two AELIO-B200 Cabinets.....	217
14.5.2	Capacity Expansion of AELIO-B200 Cabinet and AELIO-B100 Cabinet 231	
14.5.3	Pairing device after capacity expansion	240

1 Safety

1.1 General Safety

Before transporting, storing, installing, operating, using and/or maintaining the device, please carefully read and understand the document, and strictly follow the instructions and safety precautions given herein, as well as symbols affixed on the device. The safety instructions herein are only supplements to local laws and regulations.

The operator should not only abide by all safety precautions provided in the document, including but not limited to the "Danger" sign, "Warning" sign, "Caution" sign, and "Notice" sign, but also comply with relevant international, national and local laws, regulations, standards, guidelines and industry rules in the process of transportation, storage, installation, operation, and maintenance. SolaX will not assume any responsibilities for the loss caused by improper operation, or violation of safety standards for design, production and equipment suitability.

SolaX will not be liable for maintenance for possible device failure, device malfunction, or parts damage, nor will the company assume any liability to pay compensation for the possible physical and property damage resulting from the installation environment that does not meet the design requirements.

The device is well designed and tested to meet all applicable state and international safety standards. However, like all electrical and electronic equipment, safety precautions must be observed and followed during the installation of the device to reduce the risk of personal injury and to ensure a safe installation.

SolaX will not assume any responsibilities if any of the following circumstances occur, including but not limited to:

- Device damage due to force majeure, such as earthquake, flooding, thunderstorm, lighting, fire hazard, volcanic eruption, war, typhoon, tornado, etc.
- Device damage due to human cause.
- Device damage caused by strong vibrations from external factors before, during and after installation.
- Device used or operated against local policy or regulations.
- Failure to follow the operation instructions and safety precautions on the product and in this document.
- Installation and use under improper environment or electrical condition.
- Unauthorized modifications to the product or software.
- Device damage caused during transportation by the customer or the third party.
- Storage conditions that do not meet the requirements specified in this document
- Use of incompatible inverters or devices.

- Installation and commissioning operated by unauthorized personnel who are not licensed and /or satisfy state and local jurisdiction regulations.

1.2 Device Safety

To prevent personal injury or property damage from improper operation, please carefully read the following installation precautions before installation.

1.2.1 Cabinet Safety

DANGER!

- According to the local laws and regulations related to high-altitude work, operators must wear PPE, e.g., a helmet, safety belt, or waist harness, when they work at heights, while the other end of the harness must connect to a secure structure to prevent fall incidents.

WARNING!

- Please prepare tools that meet the requirements before installation, and check the number of tools after installation, to avoid leaving them inside the equipment.
- Please ensure that the cabinet has been thoroughly secured before operating it. Otherwise, it may cause personal injury or equipment damage due to tilting or collapsing the cabinet.
- Please ensure that the cabinet's vents and cooling system are working properly when it is running. If the vents are blocked, it will lead to overheating, and even equipment damage or fire hazard.
- Please ensure that the cabinet's vents and cooling system are kept away from heat sources.
- Do not drill holes in the device to avoid equipment failure.
- If the circumstances that may cause personal injury or equipment failure occur, such as, fluid flowing into the equipment, stop operation and power off immediately. Otherwise, it may cause a short circuit or damage.
- Do not open the cabinet doors on a rainy or high humid day ($\geq 80\%$ humidity). If the doors have to be opened on such days, please take proper protective measures.

CAUTION!

- Do not use a straight ladder. When electrical work is involved, a wooden ladder or an insulated ladder shall be used.
- The equipment shall not be used to provide a backup power source in the following circumstances:
 - a. Equipment related to life;
 - b. Sensitive precision instruments;
 - c. Home appliances will be faulty in the case of a power failure during operation.

NOTICE!

- The signs and messages on the labels and nameplates attached to the device need to be visible and clear.

1.2.2 Battery Safety** DANGER!**

- Do not connect the positive and negative poles of a battery together. Otherwise, it may be short-circuited. This will result in an excessive flow of current and large quantities of energy for a short time, and then will cause battery leakage, smoke, the emission of flammable gases, thermal runaway, fire, or even an explosion. Therefore, the battery must be powered off before maintenance.
- If a battery is overheated, it will cause leakage, smoke, release of flammable gases, thermal runaway, fire, or even an explosion. Therefore, please ensure that the installation site shall be well ventilated and kept away from high temperatures.
- Do not dismantle, change, shake, drop, crush, impact, cut, penetrate with a sharp object, or any other ways to damage the battery. Otherwise, it may cause leakage, smoke, emission of flammable gases, thermal runaway, fire, or even an explosion.
- Do not mix different types or makes of the battery. Otherwise, it may cause leakage or rupture, resulting in personal injury or property damage.
- The battery electrolyte is toxic and volatile. Never get in contact with the leaked liquids or inhale gases in the case of the battery leakage or odor, and contact professionals immediately. The professional must wear PPE (including but not limited to safety glasses, safety gloves, gas masks, and protective clothing) before powering off the device, and then contact our company at once after removing the damaged battery.
- Normally, the battery will not release any gases. However, in the following situations: burnt, needle-pricked, squeezed, struck by lightning, overcharged, or subject to other adverse conditions that may cause battery thermal runaway, the battery may be damaged or an abnormal chemical reaction may occur inside the battery, resulting in electrolyte leakage or production of gases. If the battery needs to exhaust flammable gas, safe emission measures must be taken to prevent fire and device corrosion.
- Do not use damaged batteries, and ensure that the installation site must be well ventilated.

 WARNING!

- Please read the document carefully before installation, operation and maintenance.
- Must arrange fire-fighting equipment in advance according to the local laws, regulations, and standards while installing and commissioning the device.
- Please check that there is no damage to the outer packaging before and after unpacking, and in the process of storage and transportation. The battery shall be correctly placed or stacked in accordance with the requirements stipulated on the labels to prevent damaging or scrapping the battery resulting from crushing or falling.

 **WARNING!**

- Must tighten screws securing cables and on the copper bars according to the torque information specified in the document, and check whether they are tightened periodically. For instance, whether there is any rust, corrosion, or any other foreign object on it, and then clean it up if any. Because the loose screw connections may result in excessive voltage drops and large currents, leading to generating a lot of heat and burning the battery.
- The battery should be charged in time after discharge, to prevent battery damage due to overdischarge. If a battery pack is stored for a long time, please periodically recharge it to protect it from damage according to the storage requirements specified in the document.
- Please charge the battery within the specific temperature range because the low temperature may result in a short circuit. Hence, do not charge it when the temperature is below the low limit of the operating temperature.
- Do not use the battery when you find a bulge, or dents on the battery housing, and contact the installer or professional maintenance personnel to dismantle and replace it. The damaged battery must be kept away from other devices and flammable and explosive articles, and do not contact it except for professionals.
- Before operation, ensure that there are no irritating or burning smells around the battery.
- Do not weld or grind near a battery. Because electric sparks or arcs may cause fires.
- Do not step, lead, stand, or set on the battery.

NOTICE!

Transportation requirements for battery:

- Relevant qualifications for the transport of dangerous goods must be obtained by the forwarding agent engaged in such businesses, and they must strictly abide by the local regulations for the transport of dangerous goods.
- Please check the battery before transportation. If a battery leaks, smells, or is damaged, do refuse to transport it.
- Please handle gently in the process of loading and unloading, transportation, and moving a battery to prevent bumping, and take effective moisture-proof measures to prevent personal injuries and battery damage.
- Unless otherwise specified, do not transport the batteries, which are classified as dangerous goods, together with food, medicine, or other additives on the same means of transport.

If the battery leaks electrolyte or any other chemical materials, the electrolyte leakage can lead to toxic gases. Therefore, do not contact with them at all times. In case of accidentally coming into contact with them, please do as follows:

- In case of inhalation: Leave the contaminated area immediately, and seek medical attention at once;
- In case of contact with eyes: Rinse eyes with running water for at least 15 minutes, and seek medical attention;
- In case of contact with skin: Wash the contact area thoroughly with soap, and seek medical attention;
- In case of ingestion: Induce vomiting, and seek medical attention.

NOTICE!

If a fire breaks out where the battery is installed, please do as follows:

- In case a battery is charging when the fire breaks out, provided it is safe to do so, press the emergency stop button and unplug the power cable;
- In case a battery is not on fire yet, use a water-based fire extinguisher or a carbon dioxide extinguisher to extinguish the fire;
- In case a battery catches fire, do not try to put it out, and evacuate immediately;
- A battery may catch fire when it is heated above 150°F/60°C. If the battery catches fire, please evacuate immediately since it will generate noxious and poisonous gases.

Recovery of damaged or wasted battery:

- Dispose of the damaged or wasted batteries according to local laws and regulations instead of placing them in the household trash or curbside recycling bins. Otherwise, it may cause environmental pollution or explosions.
- Ensure that the damaged or wasted batteries are not exposed to the following situations: high temperatures, high humidity, direct sunlight, or corrosive environments.
- Contact a battery recycling company to scrap the battery, which leaks electrolytes, or is damaged or expired.
- Please take protective steps to prevent battery short circuits before moving batteries.
- Please keep away from flammable material storage areas, residential areas, and other population centers when transporting and storing the damaged battery.

1.2.3 Inverter Safety

PV safety



- Exposure to sunlight can result in the generation of high DC voltage by PV modules, which can lead to electric shock causing severe injuries or even death.
- Never touch the positive or negative poles of the PV connecting device, and avoid touching both poles simultaneously.
- Do not ground the positive or negative poles of the PV modules.
- Only qualified personnel can perform the wiring of the PV modules.

 **WARNING!**

- Overvoltage protection with surge arresters should be provided when the PV system is installed. The grid connected inverter is fitted with SPDs on both PV input side and MAINS side.
- Please consult professionals before installing SPDs.
- Make sure that the input DC voltage does not exceed the maximum DC input voltage specified for the inverter. Overvoltage can cause irreversible damage to the inverter, and such damage is not covered by the warranty.
- PV modules should have an IEC61730 class A rating.

Inverter Safety

 **DANGER!**

- Only operate the inverter if it is in a technically faultless condition. Operating a faulty inverter may lead to electric shock or fire.
- Do not attempt to open the enclosure without authorization from SolaX. Unauthorized opening of the enclosure will void the warranty and can result in lethal danger or serious injury due to electric shock.
- Make sure that the inverter is reliably grounded before any operation to prevent the risk of electric shock causing lethal danger or serious injury.
- Only qualified personnel can perform the installation, wiring, maintenance of the inverter by following this document and the related regulations.

 **WARNING!**

- Operators must wear PPE while installation and maintenance of the device.
- During operation, avoid touching any parts of the inverter other than the DC switch and LCD panel.
- Never connect or disconnect the AC and DC connector while the inverter is running.
- Prior to conducting any maintenance, turn off the AC and DC power and disconnect them from the inverter. Wait for 15 minutes to fully discharge the energy.
- Avoid touching the inverter while it is running, as it becomes hot during operation and may cause personal injuries.

 **CAUTION!**

- Make sure that children are supervised to prevent them from playing with the inverter.
- Pay attention to the weight of the inverter and handle it properly to avoid personal injuries.

NOTICE!

- The inverter has an integrated Residual Current Monitoring Unit (RCMU). If an external Residual Current Device (RCD) is required by local regulations, verify the type of RCD required. It is recommended to use a Type-A RCD with a rating of 300 mA unless a lower value is required by the specific local electric codes. When required by local regulations, the use of an RCD type B is permitted.
- Keep all product labels and the nameplate on the inverter clearly visible and well-maintained.

1.2.4 Utility Grid Safety

NOTICE!

- Only connect the inverter to the grid with the permission of the local utility grid company.

1.3 Electrical Safety

 DANGER!

- Please make sure that the unit is free from any damage before the electrical connection.
- Do not modify, change, or dismantle the device, do not change the power-on and power-off sequences and the installation procedure written in the document, and please properly and correctly operate it.
- Do not power on the device during installation. Otherwise, it may cause a fire, personal injury, or device damage.
- Must remove earrings, rings, bracelets, watches, and any other metal jewelry before operation, to avoid electrical shock, burns, or even death.
- During operation, special insulated tools must be used to avoid electric shock or short circuit failure. The insulated tools' voltage ratings must exceed the system voltage ratings. Please refer to "12 Technical Data" for system information.

 WARNING!

- Please wear PPE, such as, protective clothing, insulating shoes, goggles, safety helmets, insulating gloves, etc., when conducting electrical wiring.
- Do not touch the power supply equipment directly, or through conductors or damp objects.
- Do not touch the parts of the equipment of which warning signs are attached, to avoid personal injury or device damage.

 CAUTION!

- Do not power on the device until it has been installed and confirmed by professionals.
- In the event of a fire, evacuate immediately and call the local fire services.

NOTICE!

- Please operate according to the safety code for power station.
- Before installation, it is necessary to set up temporary safety fences or warning lines and hang warning signs in the operation area, to prohibit non-staff from entering here.
- Please make sure that the equipment and its associated switches are off before connecting and disconnecting power cables.
- Please check whether the protective housing and insulating sleeve for an electrical component have been installed correctly after finishing installation, to avoid electric shock.
- Must turn off the output switch of the power supply equipment when maintaining its electrical terminal device and power distribution device.
- If the device is required to be powered off during troubleshooting and diagnosis, please do as the following procedure: power off > electricity testing > connecting grounding cable > hanging warning signs and setting up guardrails.
- Must hang up "Do Not Switch On" warning signs on the relevant switches or circuit breakers before completing maintenance, to prevent power connection. Do not switch on before the fault is solved.
- Do not use water, alcohol, oil, or other solvents when cleaning electrical components inside and outside the device.

NOTICE!

Grounding Requirements:

- The device's grounding impedance shall meet the requirements of local electrical safety standards.
- The equipment shall be permanently connected to a grounding wire within the building's electrical system. Please check whether the device is reliably grounded before operation. The grounding cable should be removed last while dismantling and maintaining the device.
- Do not start the device if it is not fitted with a grounding conductor.
- All acts against the grounding conductor are prohibited.
- If the device is equipped with a three-pronged socket, make sure that the ground prong is reliably grounded.
- For the device that may generate large contact currents, please make sure that the grounding terminal on the housing has been grounded before powering on, to avoid electric shock.

NOTICE!**Cable Requirements:**

- When deciding the wire diameter, and connecting or wiring cables, follow the local laws, regulations, and codes to ensure safety.
 - When external conditions (e.g., placement method, ambient temperature, etc.) change, the cable type must be verified according to IEC-60364-5-52 or local laws, regulations and standards. For instance, whether the cable's current-carrying capacity meets the requirements.
 - Before connecting power cables, please make sure that the cable labels are correctly labelled and the cable terminals are well insulated.
 - Do not loop and twist cables while conducting electrical wiring. If the length of the power cable is not enough, please replace it instead of joining or welding. Ensure that all the cables of the correct type and size are fully connected and well insulated, and the edges of cable slots and crossing holes are smooth.
-
- It is recommended to bundle similar cables with cable ties, to ensure that the inside of the device is neat and tidy and to avoid cable jacket damage.
 - Please use fireproof mud to seal the threading openings immediately after finishing wiring, to avoid the entry of water vapour or small animals.
 - Cables should be kept away from heaters or other heat sources, because a high temperature environment may result in aging and damage to cable insulation.

2 Product Overview

2.1 System Overview

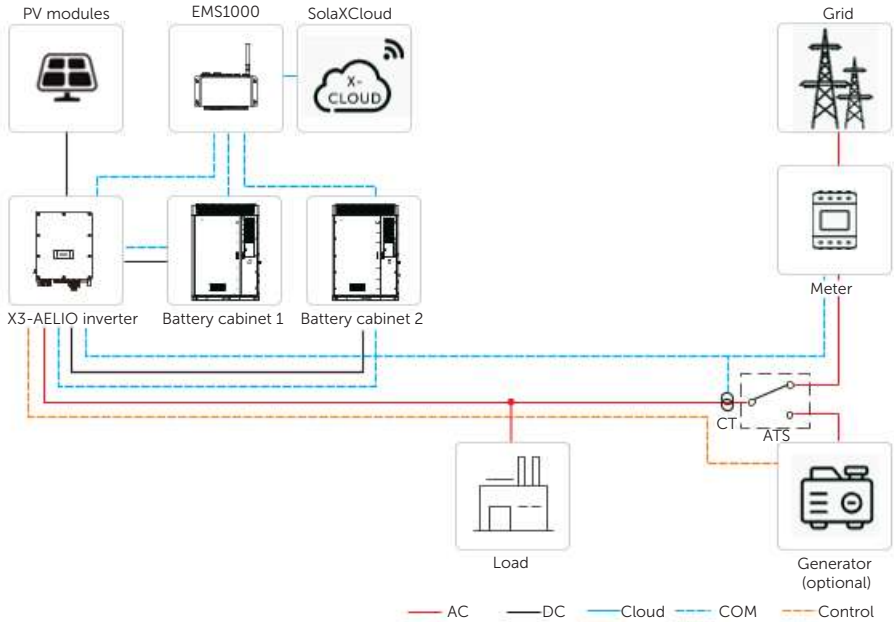

Figure 2-1 System overview diagram

Table 2-1 System item description

Item	Description
X3-AELIO series inverter	The X3-AELIO series inverter manages battery and system energy.
PV modules	PV modules work in MPPT mode. The maximum number of PV MPP tracker is five for 50 kW inverter and six for 60 kW inverter.
Battery cabinet	The AELIO-B200 cabinet integrates high-performance 280Ah LFP battery cells, high voltage box, fire supression system, air cooling system and optional EMS1000 and screen.

Item	Description
CT/Meter	The CT/meter is used by the inverter for import / export or consumption readings, and manages the battery charge / discharge accordingly for smart energy management applications.
Generator (optional)	SolaX PV-Genset solution ensures optimum interaction between the photovoltaics and diesel generator, which saves fuel, lowers energy costs and ensures a stable and reliable power supply.
Grid	380 / 220 V, 400 V / 230 V and 415 / 240 V grid are supported. Power grid TT, TN-S, TN-C-S can be supported.
EMS1000	EMS1000 is an all-in-one device for photovoltaic energy management. It integrates multiple functions involving the energy system, such as data acquisition, transmission and storage, and real-time interaction with SolaXCloud.
SolaXCloud	SolaXCloud is an intelligent, multifunctional monitoring platform that can be accessed either remotely or through a hard wired connection. With the SolaXCloud, the operators and installers can always view key and up-to-date data. There are two SolaXCloud platforms. Commercial platform can be connected through EMS1000 connection.

2.2 Product Introduction

The product "AELIO-P50B200" and "AELIO-P60B200", a smart outdoor energy storage system with easy installation and convenient expansion, integrates high-capacity battery packs, a high-performance inverter, EMS1000, high-voltage box, and fire extinguishing system in a cabinet based on the design concept of "ALL-IN-ONE". The industrial and commercial scenarios are designed to be broadly applicable.

The entire system consists of X3-AELIO series inverter, cabinet, battery packs, high-voltage box, distribution box, IO module, EMS1000, switch, and UPS.

2.3 Supported Power Grid

There are different ways of wiring for different grid systems. TT / TN-S / TN-C-S are shown below:

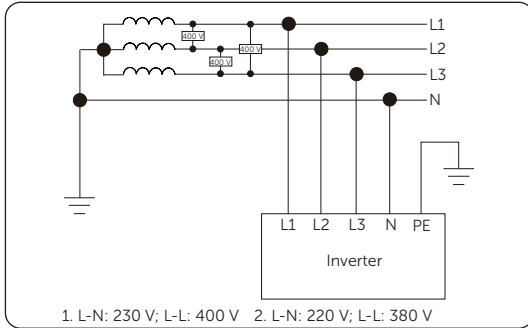

Figure 2-2 Supported power grid-TT

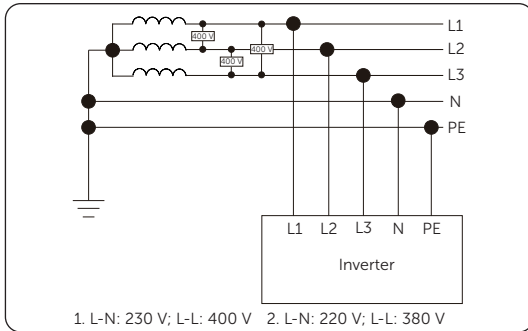

Figure 2-3 Supported power grid-TN-S

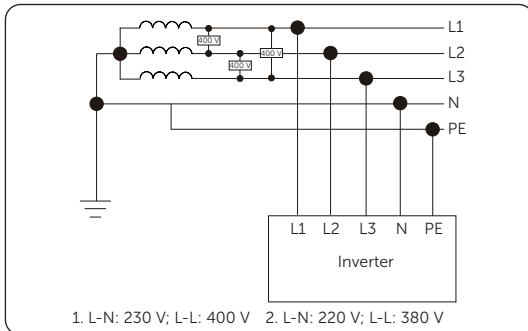

Figure 2-4 Supported power grid-TN-C-S

NOTICE!

- If a different power grid is required, please consult our SolaX after-sales team for confirmation.

2.4 Appearance and Dimension

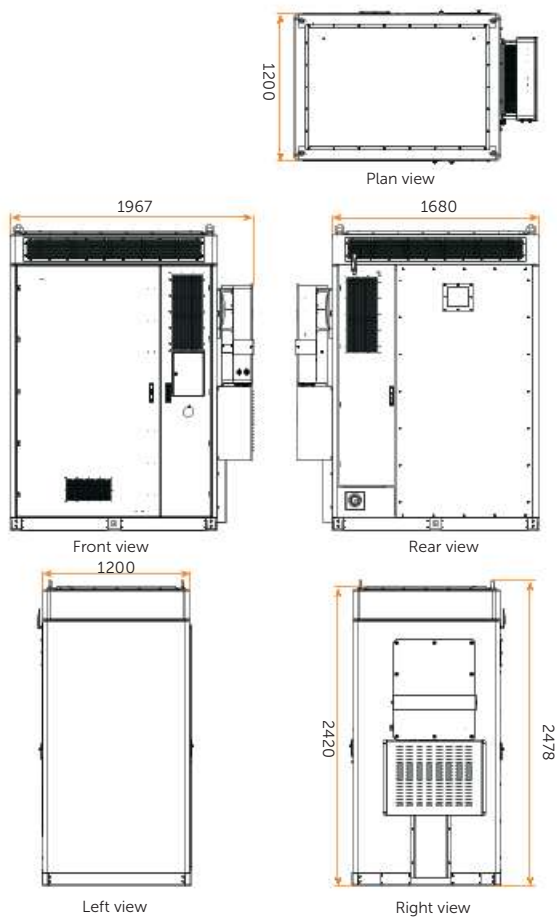

Figure 2-5 Dimension (unit: mm)

2.5 Parts Description

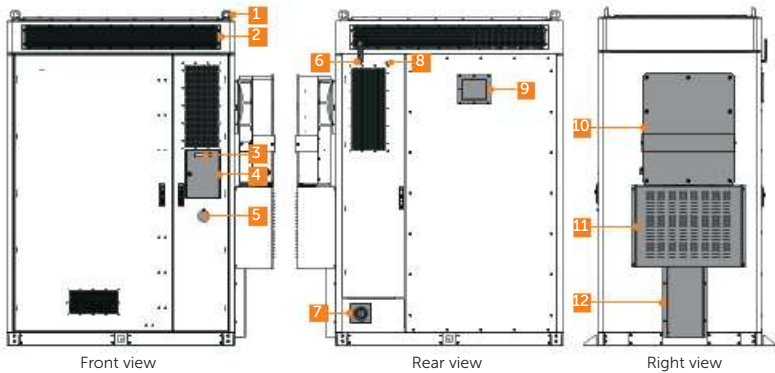

Figure 2-6 Parts description (in the closed state)

Table 2-2 Parts description

No.	Item	Description
1	Eye bolt	Material lifting applications.
2	Air conditioner	Energy storage system air conditioner.
3	LED light	To display status information of all processes running on the system.
4	Display screen	To display information of the whole system (The screen can be seen after opening the screen door).
5	Emergency stop button	To shut down the system in emergency circumstances.
6	Antenna	A 4G antenna, to connect EMS1000.
7	Fire hose nozzle	To connect the water supply sources.
8	A reserved antenna port	To connect wireless meter.
9	Expansion-proof valve	To exhaust the combustable gas out of the cabinet.
10	Inverter	SolaX's X3-AELIO inverter which is not delivered with the cabinet.
11	Large cable cover	To protect and secure cables.
12	Small cable cover	To protect and secure cables.

Inverter

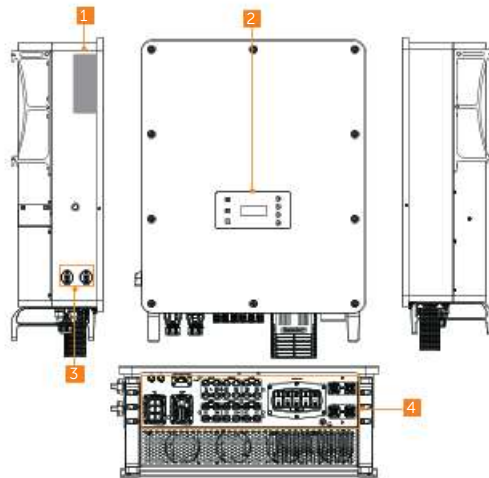

Figure 2-7 Parts description

Table 2-3 Parts description

No.	Item	Description
1	Type label	Type label clearly identifies the device type, serial number, specific DC / AC parameters, certification, etc.
2	LCD panel	Including screen, indicators and keys. Screen displays the information; indicators indicate the status of inverter. Keys are used to perform the parameter setting.
3	DC switch	Disconnect the PV DC input when necessary. DC switch 1 controls MPPT 1, 2 and 3, DC switch 2 controls MPPT 4, 5 and 6.
4	Electrical connection area	Including PV terminals, battery terminals, Grid and EPS terminals, communication terminals, etc.

Battery cabinet

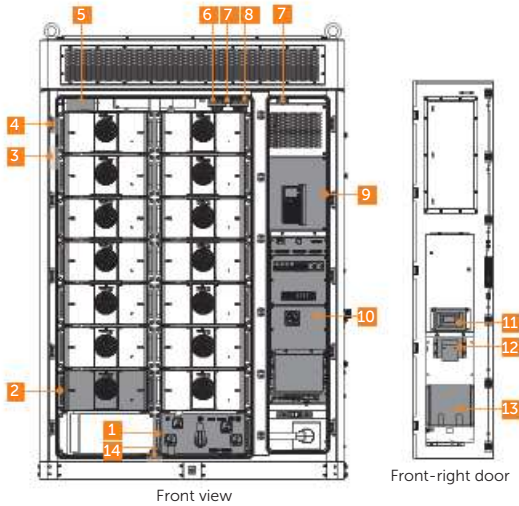
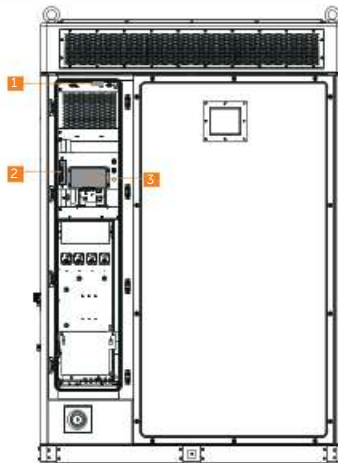

Figure 2-8 Parts description (in the opened state)

Table 2-4 Parts description

No.	Item	Description
1	High-voltage box	To collect current and voltage information on battery tower, and control the charge and discharge of battery pack.
2	Battery pack	/
3	Temperature and humidity sensor	To measure temperature and humidity.
4	CO detector	To detect CO gases.
5	Aerosol fire extinguisher	To control or suppress the spread of fire
6	Smoke detector	To detect smoke.
7	Door sensor	To alert you when the door is open.
8	Temperature sensor	To detect smoke.
9	Control area	Including IO module, UPS, etc. See "Figure 2-7" for details.
10	Distribution box	To distribute AC power for the energy storage system.
11	Control panel of air conditioner	To monitor the air conditioner and show relevant parameter.

No.	Item	Description
12	Audible and visible alarm	To alert you when the abnormal conditions occur, such as temperature, smoke.
13	File pocket	To put documents.
14	Water sensor	To detect water level based on the principle of potential difference between the two electrodes.



Rear view

Figure 2-9 Parts description (in the opened state)

No.	Item	Description
1	Door sensor	To alert you when the door is open.
2	Switch	/
3	EMS1000	A energy management system.

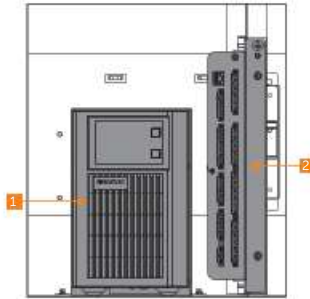

Figure 2-10 Parts description (control area)

Table 2-5 Parts description

No.	Item	Description
1	UPS	To provide backup power to ensure that the device is in a normal operating condition.
2	IO module	To collect signal and control other modules.

High-voltage box

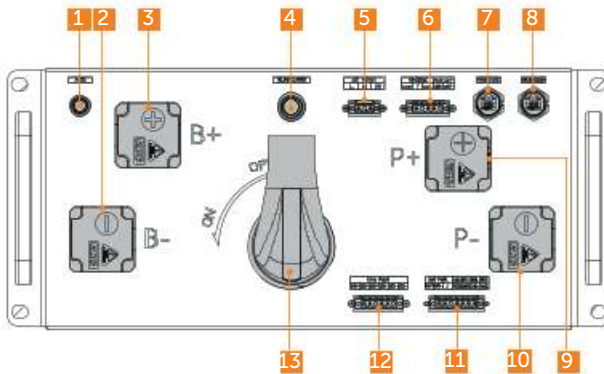

Figure 2-11 Front panel

Table 2-6 Description of front panel

No.	Item	Description
1	ADD button	To assign address.
2	Negative output port	To connect battery pack's negative terminal.
3	Positive output port	To connect battery pack's positive terminal.

No.	Item	Description
4	Power button / status light	To start up or shut down system.
5	AC220V input terminal block	To connect distribution box's CZ1.
6	Communication terminal block (for IO module)	To connect the IO module's CAN port and dry contact of the inverter.
7	Communication port (for inverter)	To connect inverter's communication port.
8	Communication port (for EMS1000)	To connect EMS1000's communication port.
9	P+ port	To connect inverter's positive terminal.
10	P- port	To connect inverter's negative terminal.
11	Terminal block (for battery pack)	To connect battery pack's communication cable and power cable.
12	Terminal block (for fan)	To connect fan's power cable.
13	Disconnect switch	To disconnect the device on the DC side.

Battery pack

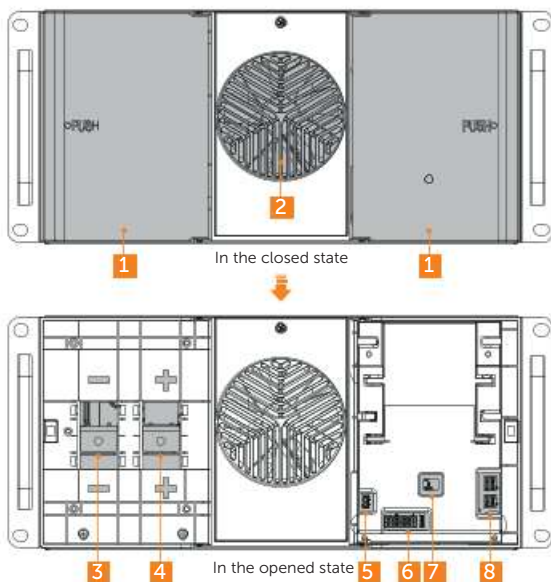

Figure 2-12 Front panel

Table 2-7 Description of front panel

No.	Item	Description
1	Left/right door	Please open the door while wiring.
2	Fan	To keep components cool in the cabinet.
3	Negative terminal	To connect negative terminal of high-voltage box or battery pack.
4	Positive terminal	To connect positive terminal of high-voltage box or battery pack.
5	Connection port (for fan)	To connect the fan.
6	Power connector (for fan)	To provide power to the fan.
7	BMS's status light	To display the running status of BMS.
8	Communication port	To connect communication cable.

Distribution box

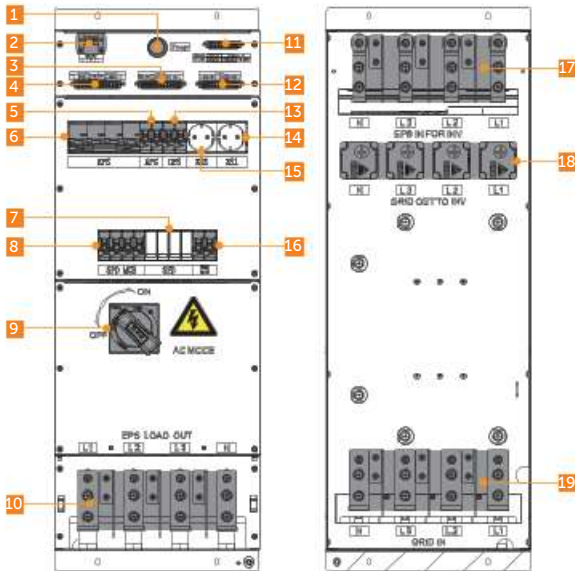

Figure 2-13 Front panel

Table 2-8 Description of front panel

No.	Item	Description
1	LED light	To display the operation state.
2	Power supply port for air conditioner	To connect to the air conditioner.
3	24V DC power supply terminal +	Positive terminal for 24V DC power supply of other devices in the cabinet.
4	220 V AC power supply terminal	Terminals for 220V AC power supply of other devices in the cabinet.
5	APS breaker	Breaker for XS2 reserved power socket.
6	EPS breaker	Breaker for EPS protection.
7	SPD	Surge protection device
8	SPD MCB breaker	SPD maintenance breaker
9	Breaker handle	Main switch for AC side.
10	EPS LOAD OUT	Copper busbars for EPS load connections.
11	Signal & control terminal	For MCCB electrical control and feedback, SPD feedback signal
12	24V DC power supply terminal -	Negative terminal for 24V DC power supply of other devices in the cabinet.
13	UPS breaker	Switch for UPS power.
14	XS1	UPS power socket.
15	XS2	Reserved power socket.
16	HVAC MCB breaker	A reserve circuit breaker for the air conditioner.
17	EPS IN For INV	Copper busbars for inverter EPS connections.
18	Grid OUT To INV	Terminals for inverter grid connections.
19	Grid IN	Copper busbars for grid connections.

Air conditioner

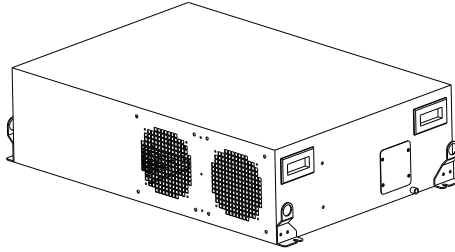

Figure 2-14 Appearance of air conditioner

The air conditioner is capable of temperature control and humidity adjustment, with two modes: automatic mode and forced mode.

- Automatic mode

Table 2-9 Information on automatic mode

Type	Description
Cooling settings	<p>Includes the cooling point temperature and cooling return difference. The air conditioner will turn on cooling when the cabinet temperature exceeds their sum, and turn off cooling when the temperature falls below their difference.</p> <p>For example, you can set the cooling point temperature to 26°C, and the cooling return difference to 2°C, and then the air conditioner will turn on cooling when the cabinet temperature exceeds 28°C (26°C+2°C), and turn off cooling when the temperature falls below 24°C (26°C-2°C).</p>
Heating settings	<p>Includes the heating point temperature and heating return difference. The air conditioner will turn on heating when the cabinet temperature falls below the their difference, and turn off heating when the temperature exceeds their sum.</p> <p>For example, you can set the heating point temperature to 15°C, and the heating return difference to 2°C, and then the air conditioner will turn on heating when the cabinet temperature falls below 13°C (15°C-2°C), and turn off heating when the temperature exceeds 17°C (15°C+2°C).</p>

Type	Description
Dehumidification settings	<p>Includes humidity setting, humidity difference, humidity dead zone and dehumidification temperature. Dehumidification starts when both conditions are met: the cabinet temperature is at least 2°C higher than the dehumidification temperature, and the cabinet humidity is higher than the sum of the humidity setting value and humidity difference. Dehumidification stops when any of the conditions are met: The cabinet temperature is lower than the dehumidification temperature, or the cabinet humidity is lower than the sum of humidity setting value and humidity dead zone.</p> <p>For example, if you set these values respectively to 50%RH, 10%RH, 5%RH and 20°C, then dehumidification starts when the cabinet temperature exceeds 22°C (20°C+2°C) and humidity exceeds 60%RH (50%+10%), and dehumidification stops when the cabinet temperature is lower than 20°C, or the humidity is lower than 55%RH (50%+5%).</p>

- Forced mode

The air conditioner can be set through the upper computer to enter the forced mode.

Table 2-10 Information on forced mode

Value	Definition
0	Automatic mode
1	Forced refrigeration
2	Forced heating
3	Forced air supply
4	Forced standby

NOTICE!

- Please refer to when "11.4.1 Disassembly and Clean of Air Conditioner Filter" it's time to clean or replace the air conditioner filter.

EMS1000

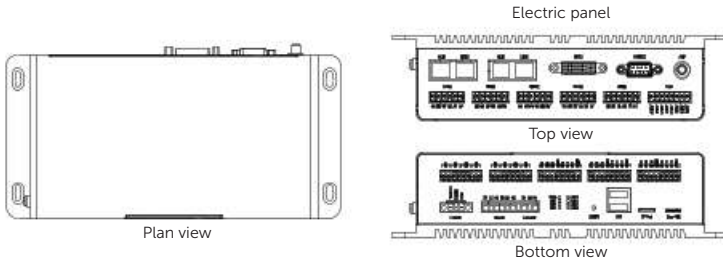

Figure 2-15 EMS1000

IO module

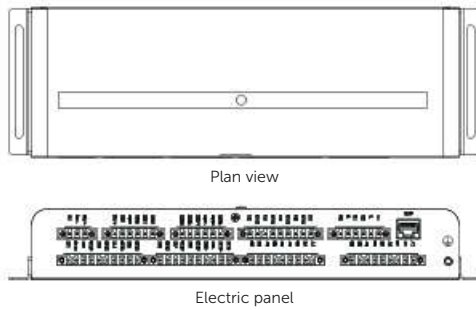

Figure 2-16 IO module

Other parts



Figure 2-17 Appearance of aerosol fire extinguisher

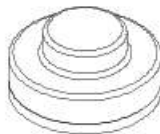

Figure 2-18 Appearance of temperature sensor

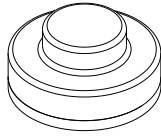

Figure 2-19 Appearance of smoke detector

NOTICE!

- A cover has been fitted on the temperature sensor and smoke detector, respectively, at the factory. Therefore, the please remove covers before using them.

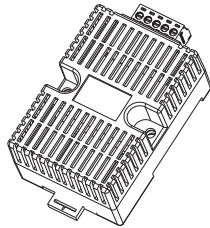

Figure 2-20 Appearance of temperature and humidity sensor

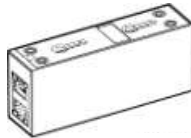

Figure 2-21 Appearance of CO detector

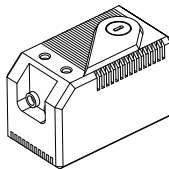

Figure 2-22 Appearance of temperature sensor

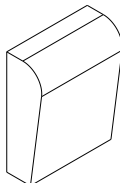

Figure 2-23 Appearance of audible and visible alarm



Figure 2-24 Appearance of water sensor



Figure 2-25 Appearance of door sensor

2.6 Indicator

Cabinet's LED light

The cabinet is equipped with a tri-colour indicator (green/yellow/red) to show the system operating status.

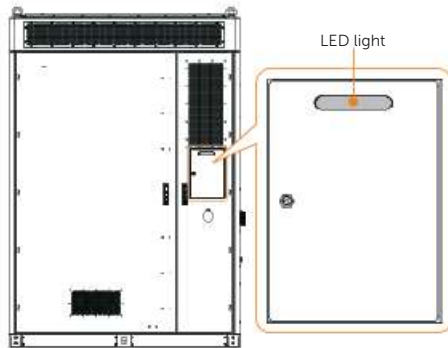





Figure 2-26 LED light

Table 2-11 Description

Status		Description
Light on		In standby
Light on		In operation
Light on		System failure

High-voltage box's indicator light

The box is equipped with a bi-colour indicator (green/red) to show its operating status.

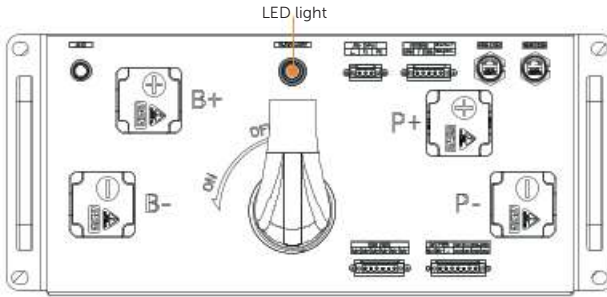

Figure 2-27 LED light

Table 2-12 Description

Status		Description
Blinking		In operation
Light on		Rely in off state
Light on		System failure

Battery pack's LED light

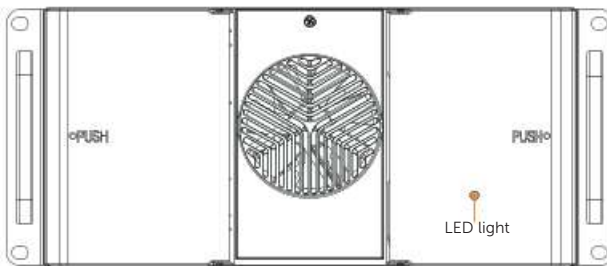

Figure 2-28 LED light

Table 2-13 Description

Status		Description
Blinking		In operation

Inverter control panel

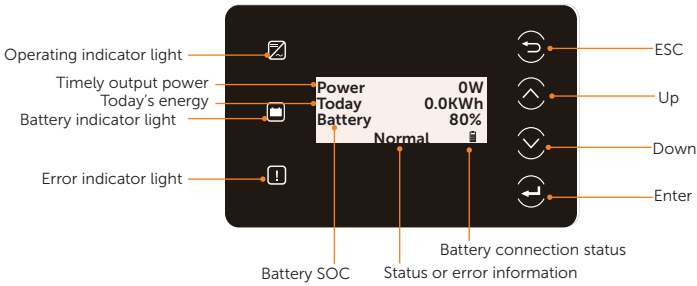

























Figure 2-29 Control Panel

Table 2-14 Description

LED indicator	Status	Definition
 Operating	Light on	 The inverter is in a normal state.
	Blinking	 The inverter is in a waiting or checking state.
 Error	Light on	 The inverter is in a fault state.
	 Battery	Light on
Blinking		 Both of the battery terminals are connected are in an idle state.
 Battery connection status	Solid display	 One of the battery terminals is connected normally at least.
	Blinking	 Both of the battery terminals are disconnected.

2.7 Symbols

Table 2-15 Description of symbols

Symbol	Description
	CE mark of conformity.
	TUV certification.
	RCM mark of conformity
	Protective grounding point.
	Grounding point.
	Caution, hot surface. The enclosure temperature may be high while running. Therefore, do not contact to avoid scalding.
	Danger, electric shock. Do not touch the device after it is powered on. Otherwise, an electric shock may occur.
	Danger. Due to possible risks, do not touch the device after it is powered on.
	Observe enclosed documentation.
	The device cannot be disposed together with the household waste.
	Do not operate the inverter until it is isolated from mains and on-site PV generation suppliers.
	Danger of high voltage. Do not touch live parts of the cabinet for 15 minutes after disconnection from the power sources.
	Danger of high voltage. Do not touch live parts of the inverter for 5 minutes after disconnection from the power sources.
	The battery system must be disposed of at a proper facility for environmentally-safe recycling.



The battery module may explode.
The rechargeable battery can become hot during operation. Avoid touch during operation.



Keep the device away from children.



Keep the device from open flames or ignition sources.

2.8 Working Mode

Six working modes are available for you to choose in on-grid status, i.e Self use, Feed-in priority, Backup, Peak shaving, Schedule and Manual. You can choose the working modes according to your lifestyle and environment.

When the power supply from the electric power company is stopped due to a power outage, it automatically switches to EPS mode and connects to the distribution board for a specific load, thereby providing power to important electrical appliances.

For how to set the working mode, please refer to the X3-AELIO Series User Manual.

2.8.1 Self-use Mode (Priority: Loads > Battery > Grid)

The self-use mode is suitable for areas with low feed-in subsidies and high electricity prices. The power of PV will supply the loads first, and the surplus power will charge the battery, then the remaining power will feed into the grid.

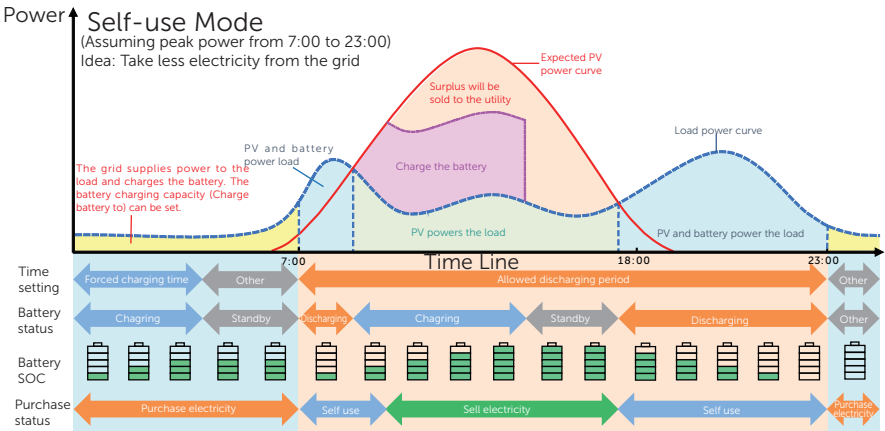

Figure 2-30 Self-use mode

Table 2-16 Description of self-use mode

Time period	Inverter working status
Forced charging period	<ul style="list-style-type: none"> Charge the battery firstly until the battery SOC reaches the specified Charge battery to value. You can configure the inverter to either draw power from the grid or not.
Allowed discharging period	PV is sufficient (PV → load → battery → grid) <ul style="list-style-type: none"> The power generated from PV prioritizes supplying the load. Any excess power is then directed towards charging the battery, and if there is still surplus electricity, it can be sold to the grid. In the event that the local utility restricts the sale of electricity to the grid, the export control value can be set on the inverter.
	PV is insufficient (PV+battery → load) <ul style="list-style-type: none"> The battery discharges power to the load, and once its capacity reaches Min SOC, it automatically ceases discharging.

Note:

Charge battery to: The battery SOC charged from grid. 10% by default, the settable range is 10%~100%.

Min SOC: Minimum SOC of the battery under grid connection. 10% by default, the settable range is 10%~100%.

Charge & Discharge period

You can set two configurable working periods: forced charging period and allowed discharging period. The interval not in the charging & discharging period belongs to other time periods.

- Forced charging period (Default period: 00:00~00:00, closed by default)

The priority of forced charging period is higher than all working modes. In the forced charging period, the inverter will charge the battery first until the battery SOC reaches the specified **Charge battery to** value set in each working mode. You have the option to configure the inverter to either draw power from the grid or not.

- Allowed discharging period (Default period: 00:00~23:59)

In the allowed discharging period, the inverter will allow the battery to discharge and charge power in accordance with the working mode and load conditions.

- Period not set as forced charging or allowed discharging period

In this period, the inverter will allow the battery to charge but can not discharge power.

NOTICE!

- The charging and discharging period is only applicable for self-use mode, feed-in priority and backup mode.

2.8.2 Feed-in Priority (Priority: Loads > Grid > Battery)

The feed-in priority mode is suitable for areas with high feed-in subsidies, but has feed-in power limitation. The power generated from PV is directed towards supplying the loads. Any excess power beyond the load requirements will be fed into the grid.

Note: If the amount of electricity sold to the grid is limited, the remaining power will be utilized to charge the battery.

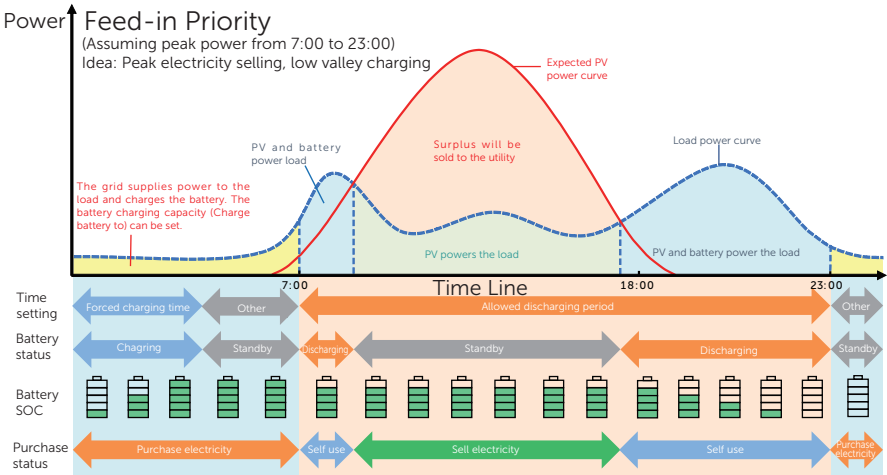

Figure 2-31 Feed-in priority

Table 2-17 Description of feed-in priority

Time period	Inverter working status
Forced charging period	<ul style="list-style-type: none"> Charge the battery firstly until the battery SOC reaches the specified Charge battery to value. You can configure the inverter to either draw power from the grid or not.
Allowed discharging period	PV is sufficient (PV → load → grid) <ul style="list-style-type: none"> The power generated from PV is directed towards supplying the loads. Any excess power beyond the load requirements will be fed into the grid,
	PV is insufficient (PV+battery → load) <ul style="list-style-type: none"> PV and battery supply power to the load at the same time, and once the battery capacity reaches Min SOC, it automatically ceases discharging.

Note:

Charge battery to: The battery SOC charged from grid. 50% by default, the settable range is 10%~100%.

Min SOC: Minimum SOC of the battery under grid connection. 10% by default, the settable range is 10%~100%.

NOTICE!

- You can set two configurable working periods: forced charging period and allowed discharging period in feed-in priority mode. Please refer to "Charge & Discharge period" for details.

2.8.3 Backup Mode (Priority: Loads > Battery > Grid)

The backup mode is suitable for areas with frequent power outages.

This mode will maintain the battery capacity at relatively high level to ensure that the emergency loads can be used when grid is off. Same working logic with self-use mode.

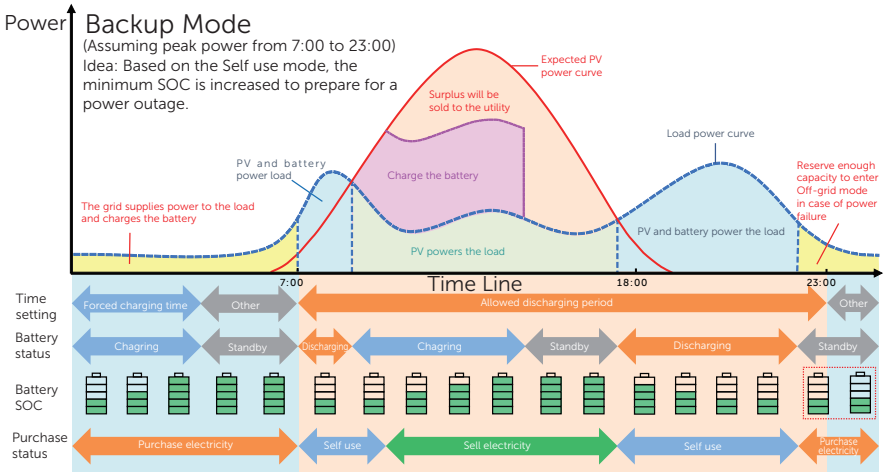

Figure 2-32 Backup mode

Table 2-18 Description of backup mode

Time period	Inverter working status
Forced charging period	<ul style="list-style-type: none"> Charge the battery firstly until the battery SOC reaches the specified Charge battery to value. You can configure the inverter to either draw power from the grid or not.
Allowed discharging period	<ul style="list-style-type: none"> The working logic remains the same as for self-use mode, but it enters a standby state when PV input is not available and the battery SOC reaches Min SOC (on-grid min SOC). In the event of a grid outage, it will switch to EPS mode until the battery discharges to Min SOC (Off-grid min SOC).

Note:

Min SOC (on-grid min SOC): Minimum SOC under grid connection. 30% by default, the settable range is 30%~100%.

Min SOC (off-grid min SOC): Minimum SOC under off-grid conditions. 10% by default, the settable range is 10%~100%.

NOTICE!

- You can set two configurable working periods: forced charging period and allowed discharging period in backup mode. Please refer to ["Charge & Discharge period"](#) for details.

2.8.4 Peak Shaving Mode

Peak shaving mode is set for leveling out peaks in electricity use. The system is intelligently controlled to ensure charging takes place during off-peak hours and discharging occurs during peak hours.

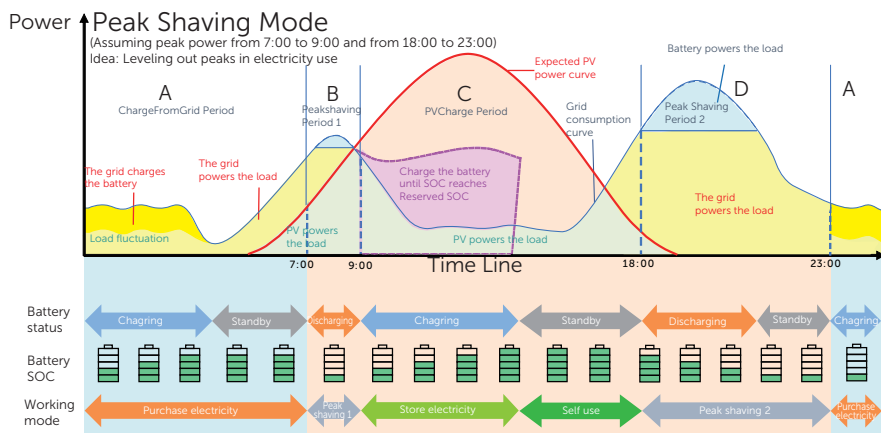

Figure 2-33 Peakshaving mode

Table 2-19 Description of peakshaving mode

Time Period	Inverter working status
Period A	<ul style="list-style-type: none"> The grid can charge the battery to MaxSOC within the set ChargePowerLimits. In this period, the battery will not discharge power.
Period B & D	<p>Grid consumption power < PeakLimits (PV+grid → load)</p> <ul style="list-style-type: none"> The PV and grid will power the load. The battery will not charge or discharge power.
Period C	<p>Grid consumption power > PeakLimits (PV + battery+grid → load)</p> <ul style="list-style-type: none"> The battery will discharge energy for loads and thus reduce the amount of energy purchased from the grid. <p>(PV → battery → load → grid)</p> <ul style="list-style-type: none"> The battery does not discharge power. The PV charges the battery up to the Reserved SOC before supplying power to the loads. Any excess power beyond the load requirements is fed into the grid.

Note:

MaxSOC: The energy taken from grid to charge the battery. 50% by default, the settable range is 10%-100%.

ChargePowerLimits: The charging power from grid. 1000 W by default, the settable range

is 0-60000 W

PeakLimits: The load consumption from grid side. 0 W by default, the settable range: 0-60000 W.

Reserved SOC: The lower limit of battery SOC required for later peak shaving period. 50% by default, the settable range is 10~100%.

2.8.5 TOU Mode

In the TOU mode, different working modes, i.e Self-use, Feedin-priority, Peaking shaving, Charging and Discharging can be set for different time periods in accordance with actual needs and environment conditions through SolaXCloud App or Web.

The day can be divided into up to 24 time slots, and the minimum time slot is 15 minutes, independent working mode can be set for each time slot. Please refer to Web Guide or App Guide for details about how to set the TOU mode.

Time Slot	Working Mode
x:xx~x:xx (e.g 0:00~0:15)	Choose one mode from Self-use / Feedin-priority / Peaking shaving / Charging / Discharging

Note:

Self-use: Same working logic with "Self-use Mode", but it is not limited by the charging and discharging time slots. The priority of PV: Loads > Battery > Grid.

Feedin-priority: Same working logic with "Feedin-priority Mode", but it is not limited by the charging and discharging time slots. The priority of PV: Loads > Grid > Battery.

Peak Shaving: The working logic is that when the power consumption from the grid exceeds the set **PeakLimit** value, the battery is allowed to discharge power. The excess power beyond the limit is provided by the combination of photovoltaic and battery to ensure that the maximum power purchased from the grid does not exceed the set limit. You need to set the **PeakLimit** value through Web or App when choosing Peak Shaving mode.

Charging: The power of PV will charge the battery as much as possible to the set SOC of **Charge BAT to** (%). You can set whether to Charge from grid. The default value of **Charge BAT to** (%) is 100%. When the battery reaches the set SOC, the surplus power will perform "Self-use Mode" or supply to the grid (based on the system setup), at this point, **Charge from grid** is not allowed.

Discharging: If allowed by the battery, the system outputs a specified power from the grid based on the set output percentage, controlling the power at the AC port. You need to set the **RatePower** (%) through Web or App when choosing Discharging mode. When the battery **Discharge to** (%) reaches the set SOC, the inverter performs "Self-use Mode".

2.8.6 EPS Mode (Priority: Loads > Battery)

During a power failure, the system will provide uninterrupted power supply to the EPS loads using the power from PV and the battery. It is important to ensure that a battery is installed, and the EPS loads should not exceed the maximum output power of the battery.

The power generated by PV will prioritize supplying power to the loads, while any surplus power will be utilized to charge the battery.

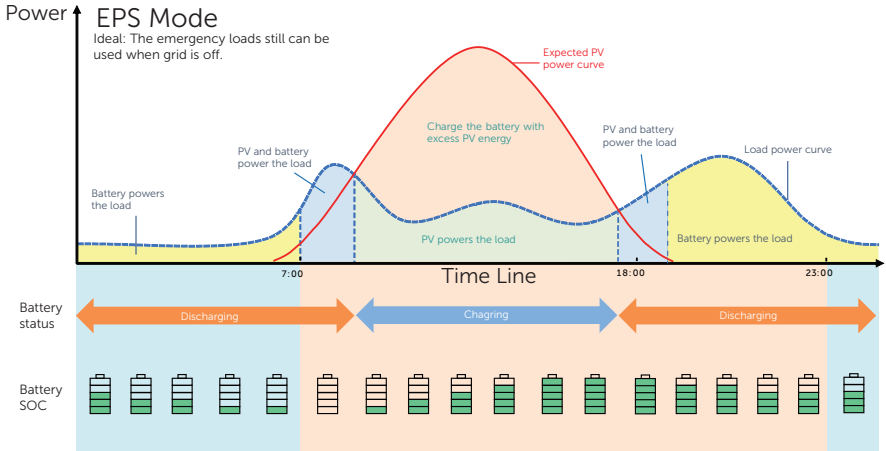

Figure 2-34 EPS mode

Table 2-20 Description of EPS mode

Battery SOC	Inverter working status
Battery SOC > Min SOC (off-grid min SOC)	<p>PV is sufficient (PV → load → battery)</p> <ul style="list-style-type: none"> The PV prioritizes supplying power to the load, with any excess energy being directed towards charging the battery.
Battery SOC ≤ Min SOC (off-grid min SOC)	<p>PV is insufficient (PV+battery → load)</p> <ul style="list-style-type: none"> The PV prioritizes supplying power to the load. If the energy is not enough, the battery will discharge power until the battery SOC reaches Min SOC and then error of BatPowerLow will be reported. <p>The inverter reports BatPowerLow. When there is PV, it will charge the battery first. After charging to the set Min ESC SOC value, it will be automatically recovered and enter EPS mode again.</p>

Note:

Min SOC: Minimum SOC of the battery under off-grid conditions. 10% by default, the settable range: 10%-100%.

Min ESC SOC: The minimum SOC of the battery to enter EPS mode. 30% by default, the settable range: 15%-100%.

2.8.7 Manual Mode

This working mode is only for the after-sales team to do after-sales maintenance. It includes **Forced Discharge**, **Forced Charge** and **Stop chrg&dischrg**. The system will restore to the original working mode after six hours Manual mode set.

2.8.8 Export Control Function

Solar export control is a limit on the amount of energy that your solar system can export into the grid. You have a set limit on how much energy you can export to the grid.

How export control works

- CT/meter required
- Correct setting of the limit value of **Export Control** through inverter. (For parallel system, set on the master inverter)

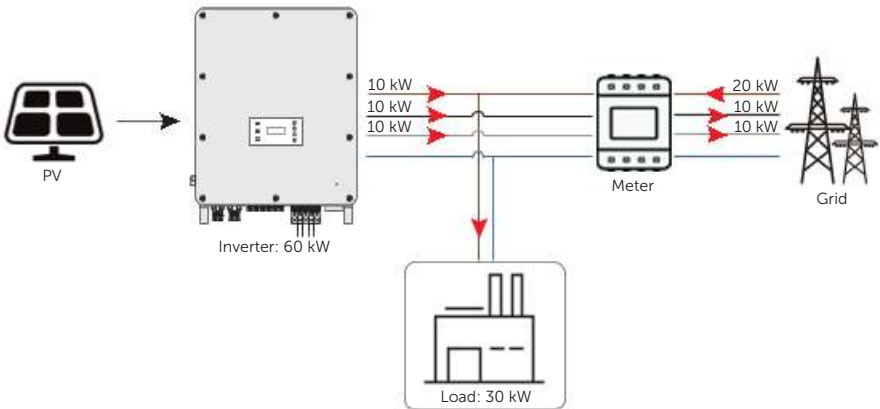

Figure 2-35 Zero export control with **Phase Unbalance** disabled

NOTICE!

- The power taken from the grid is equal to the power fed into the grid.

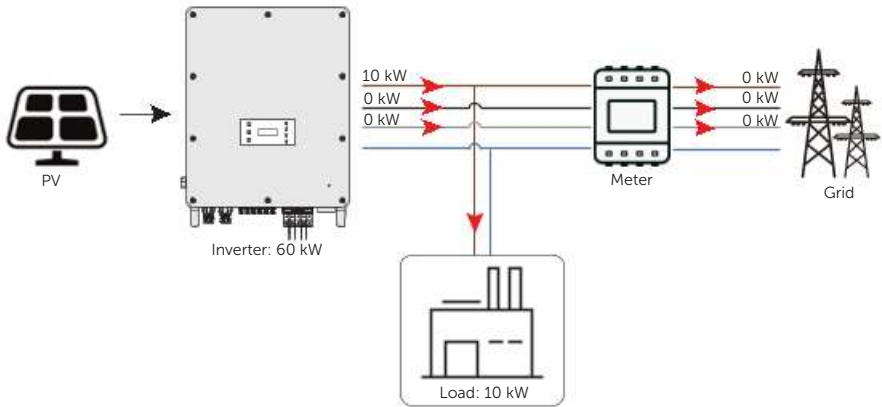

Figure 2-36 Zero export control with **Phase Unbalance** enabled

Note:

Export Control value can be set from 0W to more than the rated output power.

2.9 Application Schemes

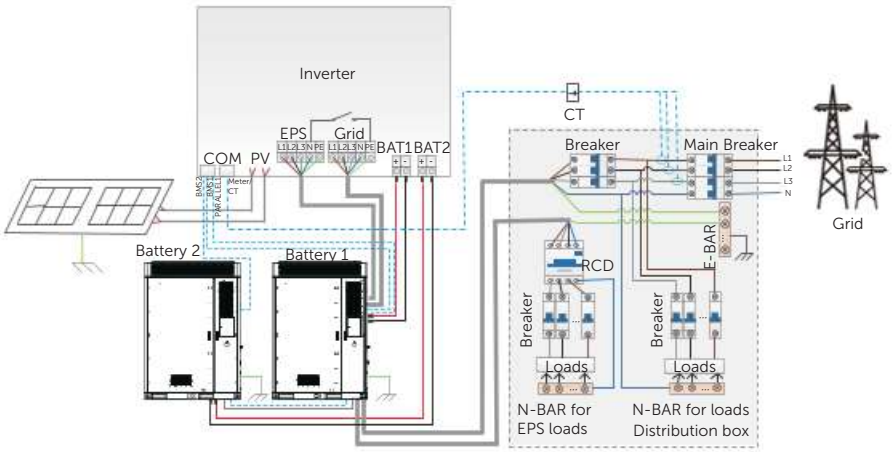

Figure 2-37 Partial load backup for Europe

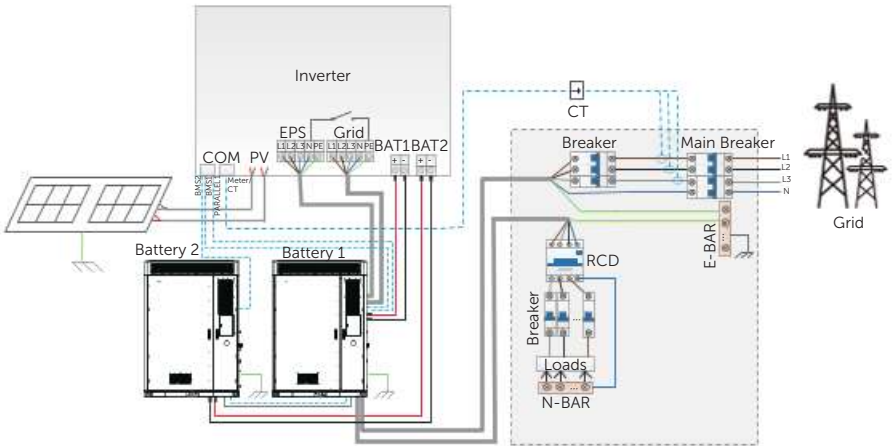

Figure 2-38 Whole load backup for Europe

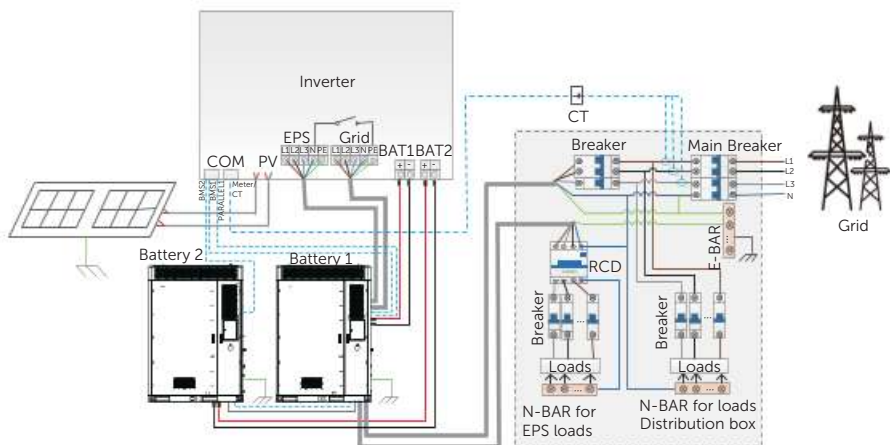

Figure 2-39 Partial load backup for Australia

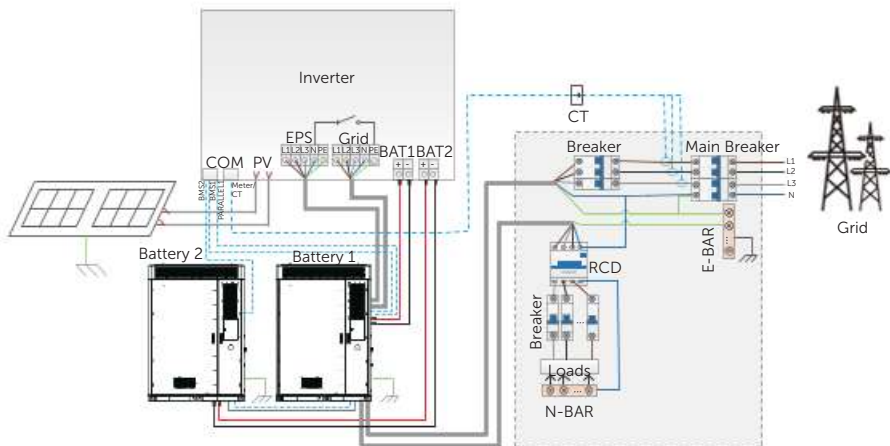

Figure 2-40 Whole load backup for Australia

NOTICE!

- The BAT 1 and BAT2 terminals of the inverter are positioned vertically, with the positive pole on the left side and the negative pole on the right side. The battery terminals shown in the figure above are for illustrative purposes only, please refer to the actual product for accurate information.

2.10 Operating Principle

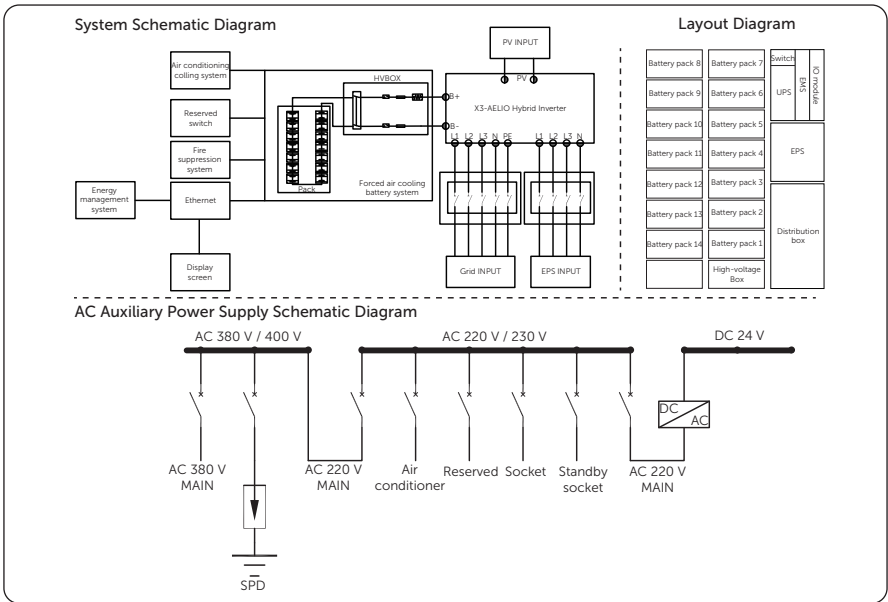

Figure 2-41 Electrical block diagram

NOTICE!

- In an off-grid situation, the current will vary due to the types of electrical loads. The common electrical load can be classified into following types, resistive load, inductive load, capacitive load, half-wave load, etc. Therefore, the types of electrical loads shall be fully considered when designing and configuring a system. In the case of a half-wave load, the load power shall not exceed 1 kW; in the case of an uncertain electrical load, please contact the supplier for evaluation of output supply to special loads.

3 Transportation and Storage

3.1 Transportation

3.1.1 Battery Cabinet Transportation



- Please be careful to avoid physical collisions during transportation. Do not place the equipment upside down, be exposed to water, etc., which may result in equipment damage, or even a fire or an explosion.

NOTICE!

- Please strictly comply with the transportation requirements of the warning signs on the packaging and equipment.
- To reduce product damage caused by shocking, tilting or impacting during transportation, it is recommended to consider sea or road (with better conditions) transport instead of rail and air transports.
- Relevant qualifications for the transport of dangerous goods must be obtained by the forwarding agent engaged in such businesses, and they must strictly abide by the local regulations for the transport of dangerous goods. Please check the battery before transportation. If a battery leaks, smells, or is damaged, do refuse to transport it.

Forklift

- Please confirm that the forklift's load-bearing capacity shall be ≥ 5 t before using it.
- The forklift should meet the following requirements: length of fork blade > 1400 mm, width of fork blade between 610 mm and 860 mm, and thickness of fork blade between 20 mm and 90 mm.

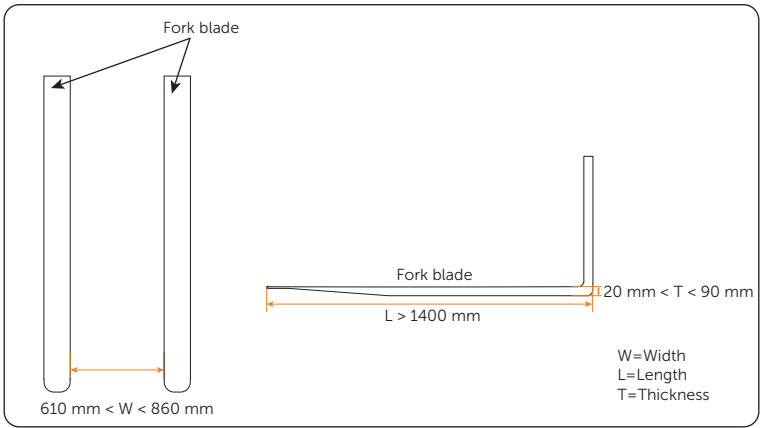

Figure 3-1 Forklift requirements

- Before moving the device, please pay attention to the center of gravity position of the load, and fully secure the load on the forklift by securing measures, such as ropes or bindings. In addition, please designate a person to supervise for safety concerns during transportation.
- The equipment can only be transported by forklift before unpacking, please accurately insert the fork blade into the fork holes on the wooden crate when moving the device.

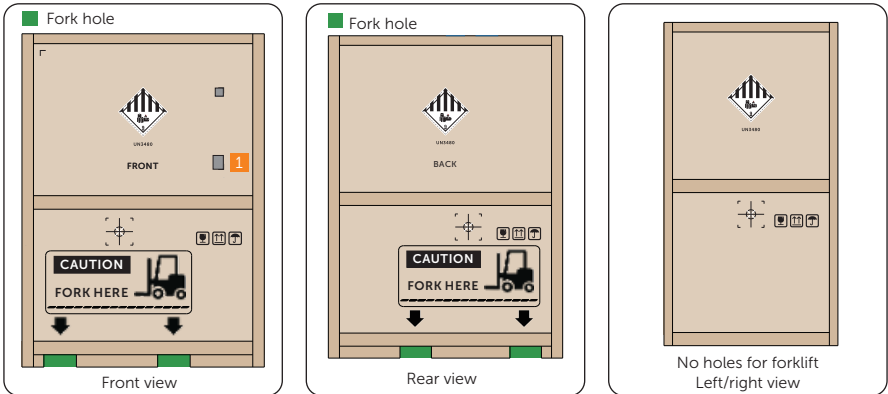

Figure 3-2 Wooden crate fork holes

- During transportation, the inclination angle of the cabinet before and after unpacking shall be: $\alpha \leq 15^\circ$. Before unpacking, if you see the red indicator on the label ($\alpha > 75^\circ$) during transportation, the tipping has occurred.

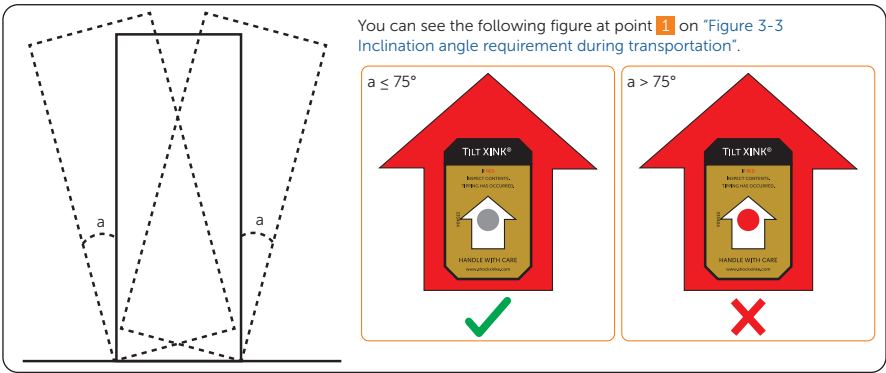

Figure 3-3 Inclination angle requirement during transportation

WARNING!

- In the case of $a > 15^\circ$, the cabinet must be left to settle for 4~24 hours after delivery to the destination, to avoid the return of lubricating oil in the compressor and the incorrect flow direction of refrigerant. Otherwise, the compressor might not be operating smoothly or even be damaged due to the lubricating oil flowing into the cylinder or coil cavity, or the compressor would not be operating smoothly due to the abnormal return of the refrigerant.

- For specific fork holes after unpacking, please refer to "6.2 Battery Cabinet Handling".

Hoisting

- A hoist operator with good operational skills and safety awareness, who must be trained and certified, shall be operated according to the local laws and regulations.
- After unpacking, the following requirements must be met when working with cranes and lifting ropes: crane hoisting capacity ≥ 5 t, hoisting operating radius ≥ 2 m.
- Before hoisting, please check:
 - » Lifting tools are complete, tested and fully secured.
 - » The device door is closed and locked to avoid accidental opening.
 - » The lifting rope's quality must meet standards, and it shall be fully secured, to avoid falling and fraying.
- Do not hoist outdoors in rain, snow, wind and other bad weather.
- It is recommended to hoist devices in sequence and to ensure that the hoist moves in the same direction.

3.1.2 Inverter Transportation

If the inverter is not put into use immediately, the transportation and storage requirements needs to be met:

- The inverter must be transported in its original packaging. SolaX will not be held responsible for any damage to the inverter caused by improper transportation or by transportation after it has been installed.
- Observe the caution signs on the packaging of inverter before transportation.
- Pay attention to the weight of inverter. Be cautious to avoid injury when carrying X3-AELIO (gross weight: 130 kg). Lifting device is recommended.
- The inverter with a package should be transported by forklift to the location where it needs to be placed.

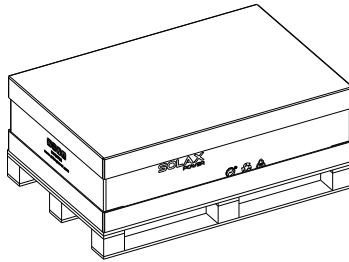

Figure 3-4 Caution signs on the packaging

3.2 Storage

3.2.1 Cabinet Storage

- For long-term storage, do not remove the original packaging and check the packaging regularly.
- Please strictly comply with the storage requirements of the warning signs and other information on the packaging to avoid device damage.
- Storage temperature: $-20^{\circ}\text{C} \sim +60^{\circ}\text{C}$.
- Relative humidity for device storage: $5\% \sim 95\%$.

NOTICE!

- Since the batteries have been installed in the cabinet in the factory, the storage requirements for the battery must also be abided by when storing the cabinet.

Battery storage



- The battery must be stored indoors, which the environment should meet the following requirements: 1. Avoiding direct sunlight and keeping out of rain; 2. Dry and well-ventilated; 3. Keeping away from heat and fire sources; 4. Keeping away from radiation; 5. Keeping away from chemicals; 6. Keeping away from dust and metal conductive dust; 7. Being equipped with fire facilities.
- Batteries must be stored in accordance with the requirements of the warning signs and other information on the packaging.
- Do not store with any other electronic equipment, chemicals, or other items that may cause interference or danger.
- Please pay attention to the height when stacking batteries to avoid deforming or damaging the battery at the bottom.

NOTICE!

- Do not store the batteries for a long time. If long periods of storage are unavoidable, please recharge it periodically to avoid battery damage. For details, see the table below.

Table 3-1 Maintenance of battery pack

Circumstance	Measure
If the ambient temperature for storage is between 30°C and 50°C	Recharge the battery packs at least once every 6 months
If the ambient temperature for storage is between -20°C and 30°C	Recharge the battery packs at least once every 12 months.
In the first installation	The interval among manufacture dates of battery packs shall not be exceed 3 months.
If a battery module is replaced or added for capacity expansion	Each battery's SOC should be consistent. The max. SOC difference should be $\pm 5\%$.
If users want to increase their battery system capacity	Ensure that the SOC of the existing system capacity is about 40%. The manufacture date of the new battery pack shall not exceed 6 months. If the manufacture date of the new one exceeds 6 months, please charge it to around 40%.

- Regarding with the storage information, see the following table:

Table 3-2 Storage information

Storage temperature range	Storage time
50°C to 60°C	3 months
30°C to 50°C	6 months
-20°C to 30°C	12 months

- Relative humidity for device storage: 5% ~ 95%.
- If the battery has been stored for more than 1 year, it must be checked and tested by professionals before use.

3.2.2 Inverter Storage

- The inverter must be stored indoors.
- Do not remove the original packaging material and check the outer packaging material regularly.
- The storage temperature should be between -40°C and +70°C . The humidity should be between 0% and 65%.
- Stack the inverter in accordance with the caution signs on the inverter carton to prevent their falling down and device damage. Do not place it upside down.

4 Preparation before Installation

4.1 Installation Site Selection

The installation site is critical to the safety, service life, and performance of the device, and it should be convenient for electrical connections, operation, and maintenance. Therefore, the installation site should be selected according to the *NFPA 855 Standard for the Installation of Stationary Energy Storage Systems* and the local laws and regulations.

The installation site shall meet the following requirements:

- Laws, regulations and industry standards: The selection of installation sites must strictly comply with local laws, regulations, and related industry standards.
- Fire safety: Fire extinguishers must be configured at the installation site according to the local fire codes, and a port for the water fire extinguishing system shall be reserved.
- Installation location: It is recommended to install the device outdoors.
- Safety spacing:
 - » The installation distance between the device and residential areas, population centers, or production buildings should meet the requirements of the local fire codes and standards.
 - » If the safety spacing cannot be met, a firewall that meets the requirements of the local fire codes must be built between the device and adjacent buildings. During the planning phase, it is crucial to consider the space for transportation, installation and maintenance of the device.
- Flood and waterlogging prevention:
 - » Avoid low-lying and flood-prone areas. The installation site that the device is to be located must be at least 250 mm higher than the highest water level in history.
 - » Since winds and wind-driven waves from rivers, lakes, and seas can affect the device, the foundation must be built at least 0.6 m higher than the maximum wave height in history.
 - » If a large amount of water flows in or through the energy storage power station, drainage facilities should be set up.
 - » If the installation site is prone to water accumulation, take waterproof measures, including but not limited to installing water baffles, configuring a drainage system, or raising the height of the foundation to prevent device damage.
- Avoid liquid intrusion: The installation area should be far away from the area where liquid is likely to be generated or leaked to avoid device failure.

- Good transportation: Good transportation for the installation site.
- Reserve space: During the planning phase, please consider the space for capacity expansion or connection in parallel in the future.
- Avoiding bad soil: Do not install devices on the undesirable soil that are prone to deformation and settlement.
- Keeping away from salt-damaged and polluted areas: Since the salt-damaged and polluted areas may corrode the device, the installation site must meet the following requirements:

Table 4-1 Installation spacing requirements

	Safety Distance
Distance from coastal areas	> 2000 m
Distance from heavy pollution sources, such as smelters, coal mines, thermal power plants	> 1500 m
Distance from moderate pollution sources, such as chemical plants, rubber plants, and electroplate factory	> 1000 m
Distance from light pollution sources, such as food processing plants, leather processing plants, heating boiler factory, slaughter houses, dumping sites, and sewage treatment stations	> 500 m

- Additional fence: For security reasons, the installation area should be surrounded by locking fences or walls accessible to qualified persons only.
- Installation environment requirements:
 - » Temperature: -30°C ~ +50°C.
 - » Relative humidity: 0 ~ 100% RH.
 - » Altitude: Below 3000 meters.
 - » Good ventilation.
 - » Keep away from sandy and dusty environments.
 - » Keep away from high temperature environment such as heat source and fire source, etc.
 - » Keep away from flammable and explosive materials and areas with dust.
 - » Keep away from corrosive substances.
 - » Keep away from strong electromagnetic fields and antenna.
 - » Keep away from strong vibration and noise sources.
 - » Keep away from areas with radiation.
 - » Keep away from areas with metal conductive and magnetic dust.
 - » Keep away from areas that produce or have toxic and harmful gases.
 - » Keep away from environments that are prone to microbial growth.

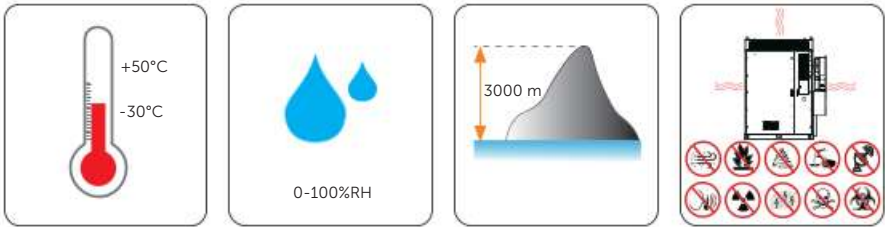

Figure 4-1 Installation environment requirements

NOTICE!

When the installation site fails to meet above requirements, please contact SolaX.

4.1.1 Installation Foundation Requirements

The requirements for foundation are shown as follows:

- Type of foundation material: 1. Non-combustible materials such as solid bricks or concrete; 2. Steel.
- The bottom of the foundation pit must be strengthened and filled. The surface of the foundation shall be solid, flat and level (horizontal error $\leq 3\text{mm}$, tilt angle $\leq 5^\circ$). Sunken or tilted foundation is not acceptable.
- The foundation's bearing capacity shall exceed 5 t. Otherwise, a retest is required.

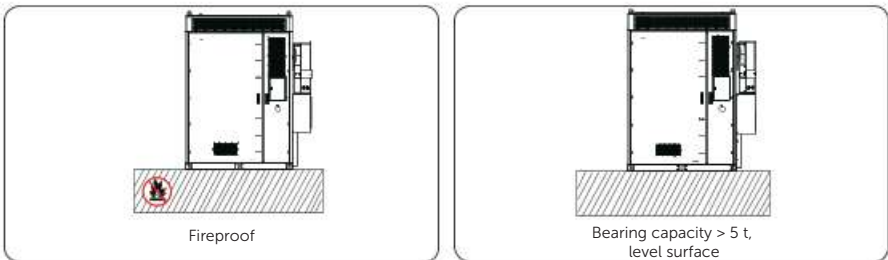

Figure 4-2 Foundation requirement

- A qualified drainage facility, of which the drainage capacity meets the requirements of the heaviest rain records in local history, shall be established according to the local geological conditions and municipal drainage standards.
- Reserve a trench or cable entry hole during the design phase.
- Avoid cables buried underground when constructing the foundation.
- The foundation drawing is only for reference. Operators shall recheck and revise it according to the environment, geological conditions, seismic requirements, etc. of the installation site.

Concrete foundation

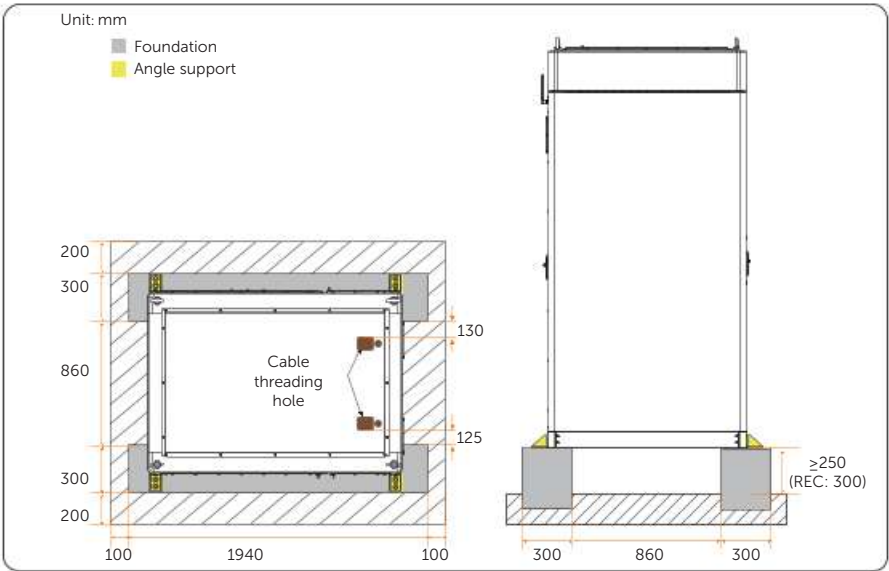

Figure 4-3 Foundation requirements for angle supports installed at front and rear sides

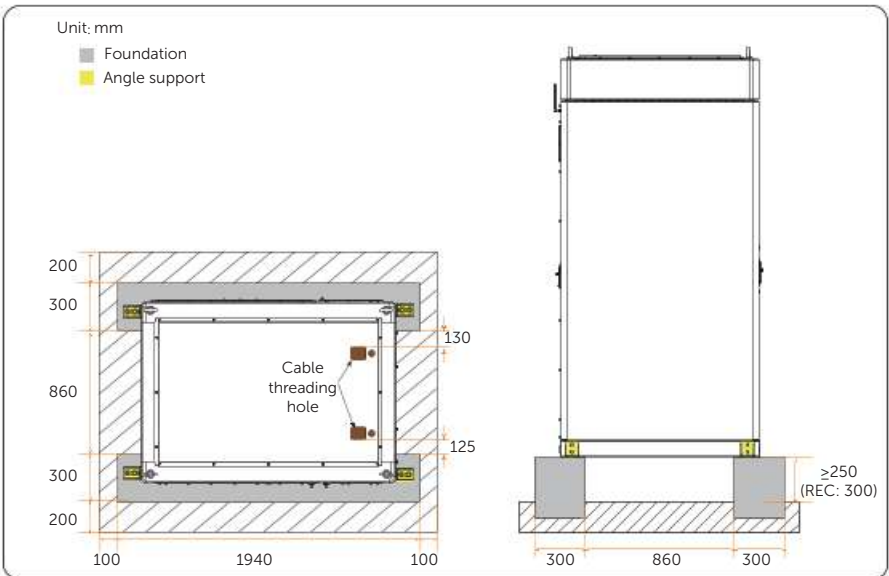

Figure 4-4 Foundation requirements for angle supports installed at left and right sides

Steel foundation

If users want the foundation to be made of steel, the foundation must meet the following requirements:

- Bearing capacity: > 5 t;
- Corrosion resistance: it is recommended to be subjected to a 720 hrs salt spray test;
- Dimension and others: see the following figures.

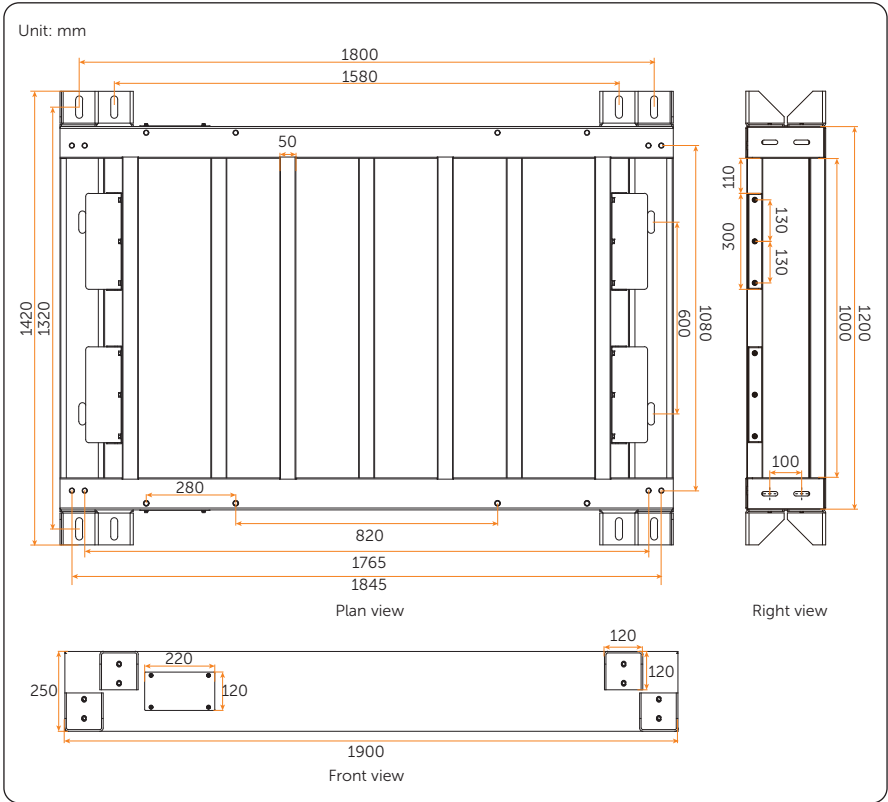

Figure 4-5 Dimension of steel foundation

Preparation before Installation

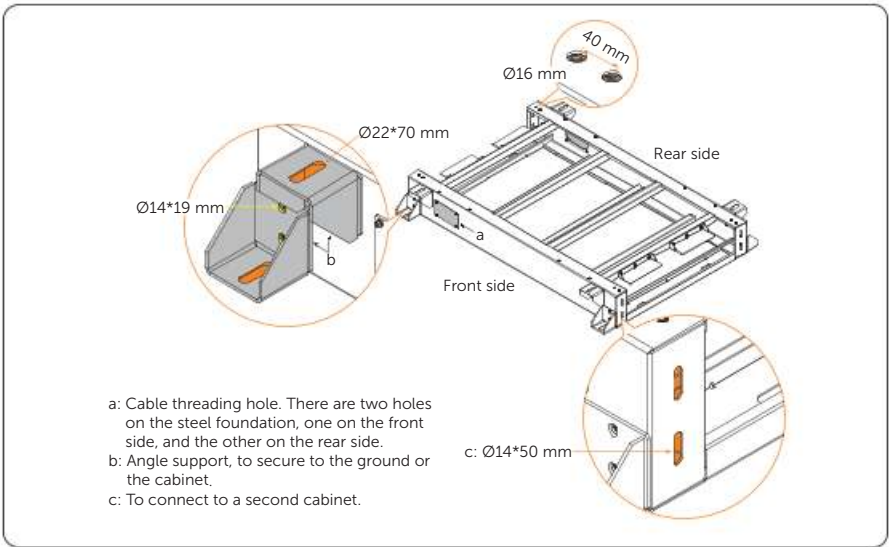

Figure 4-6 Detail description of steel foundation

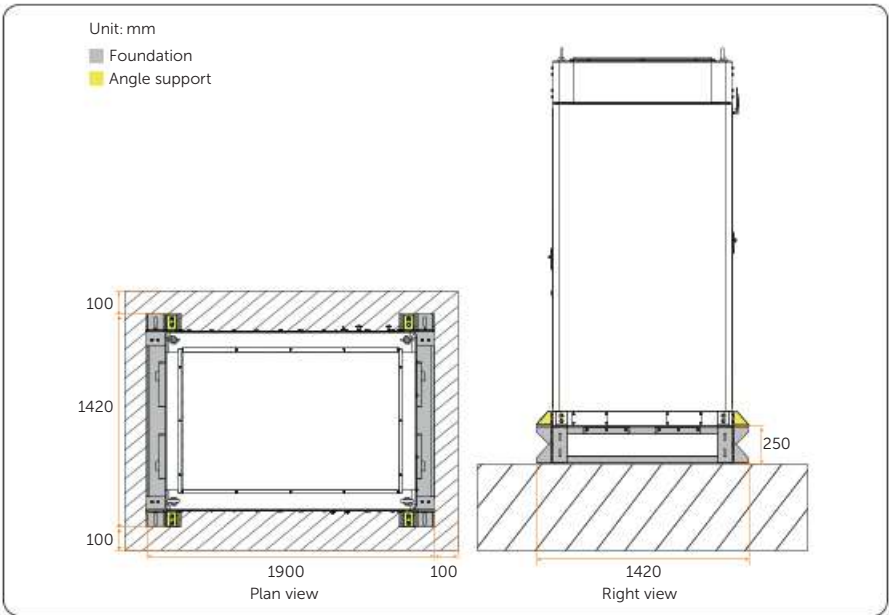

Figure 4-7 Angle supports at front and rear sides

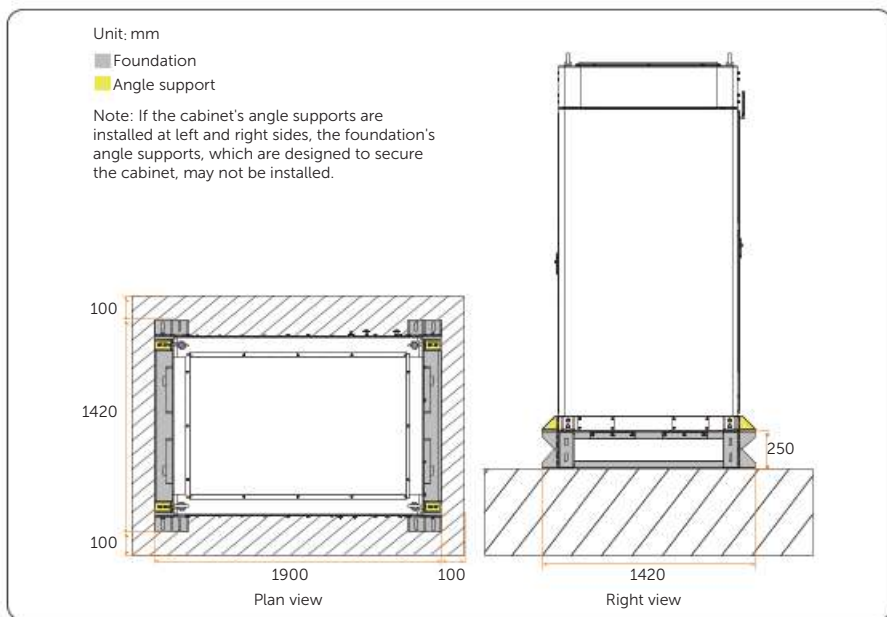

Figure 4-8 Angle supports at left and right sides

NOTICE!

After completing construction of the steel foundation, please strictly comply with the following steps:

- a. Install the bottom angle support first to secure the foundation to the ground;
- b. Install the top angle support (if any);
- c. Finally, install the cabinet onto the steel foundation.

After the steel foundation is finished, the installation procedure for cabinet can be referred to “[6 Mechanical Installation](#)”.

4.1.2 Clearance Requirement

This device has multiple installation methods:

- Single cabinet (see Figure 4-9)
- Multiple cabinets (see Figure 4-10 and Figure 4-11)

In order to ensure the heat dissipation of the inverter and facilitate disassembly, the minimum space to be reserved around the cabinet must meet the following standards.

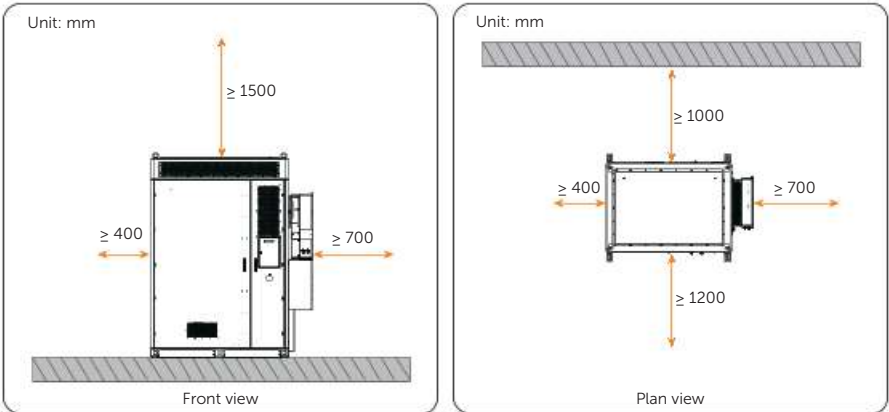

Figure 4-9 Single cabinet

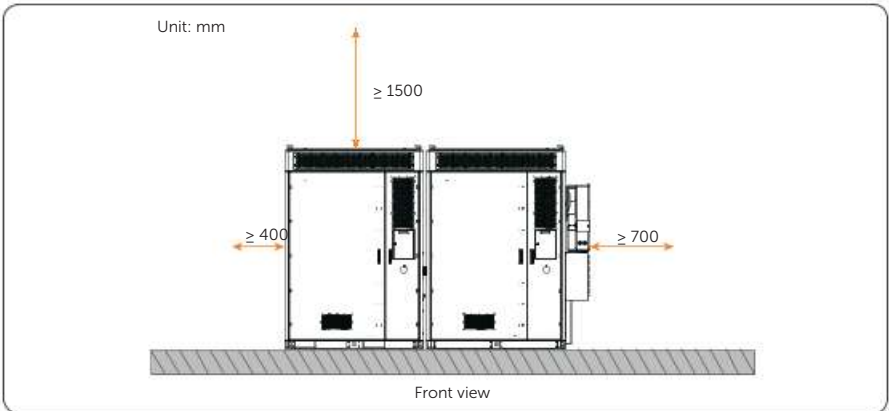

Figure 4-10 2 and more cabinets

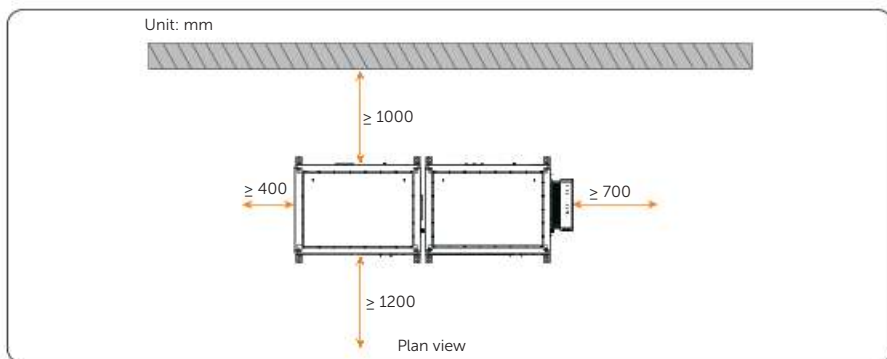
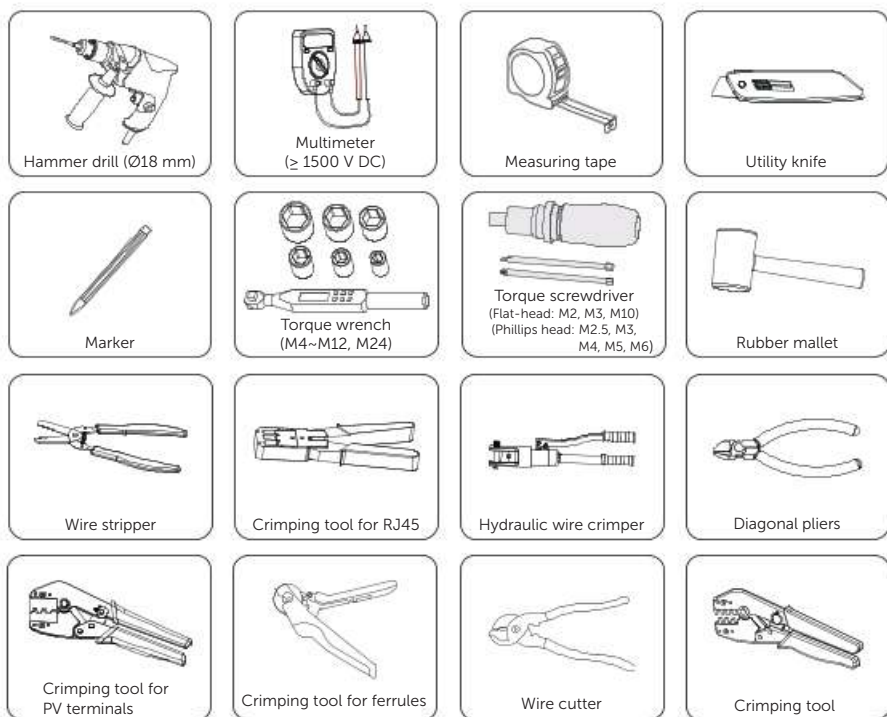

Figure 4-11 2 and more cabinets

4.2 Tools Requirement

Installation tools include but are not limited to the following recommended ones. If necessary, use other auxiliary tools on site.









Preparation before Installation



4.3 Additionally Required Materials

Table 4-2 Additionally required wires

No.	Required Material	Type	Conductor Cross-section
1	PV cable	 Dedicated PV cable with a voltage rating of 1000 V, a temperature resistance of 105 C , a fire resistance grade of VW-1	6 mm ²

No.	Required Material	Type	Conductor Cross-section
2	Communication wire 1	 Network cable CAT5E	/
3	Communication wire 2	 Four-core signal cable	0.25 mm ² -0.3 mm ²
4	Grid wire	 Five-core copper cable * The conductor cross-section of copper cables connecting to the distribution box (a total of 4 copper cables) is 35 mm ² , as well as 16 mm ² for a copper cable that is connected to the grounding.	35 mm ² * 4 + 16 mm ² * 1
5	EPS wire	 Four-core copper cable * The conductor cross-section of copper cables connecting to the cabinet (a total of 4 copper cables) is 35 mm ² .	35 mm ² * 4
6*	Grounding plate	 Galvanized iron plate	Width: 40 mm Depth: 4mm
7*	Additional PE wire	 Conventional yellow and green wire	> 25 mm ²

NOTICE!

The device supports grounding plate connection and PE connection, please prepare the grounding plate or the additional PE wire according to the actual needs.

Table 4-3 Additionally required materials

No.	Required Material	Type
1	Ring terminal	 TLK16-8 ring terminal

5 Unpacking and Inspection

5.1 Battery Cabinet Unpacking

5.1.1 Unpacking

- The device undergoes 100% testing and inspection before shipping from the manufacturing facility. However, transport damage may still occur. Before unpacking the rechargeable battery, please verify that the model and outer packing materials for damage, such as holes and cracks.
- Due to the cabinet height exceeding 2m, please take necessary precautions for working at heights when removing the outer packaging. The unpacking procedure can be referred to the following Figure.

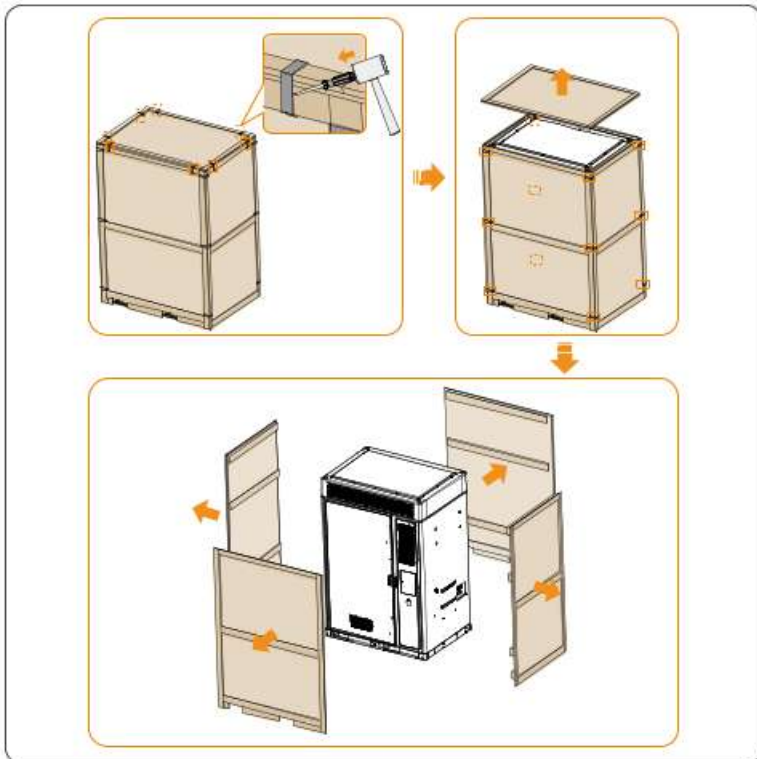

Figure 5-1 Unpacking

- When unpacking, please handle all packaging materials properly for future storage or relocation of this device.
- After unpacking, please check if the device is intact and if all accessories are complete. If there is any damage or missing accessories, please contact your dealer immediately for assistance.

5.1.2 Packing List

Battery cabinet

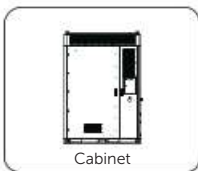
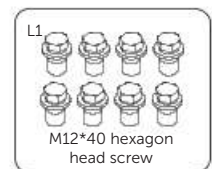
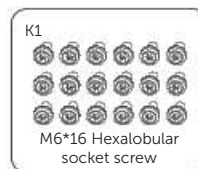
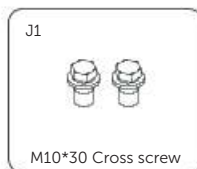
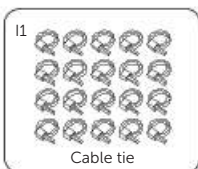
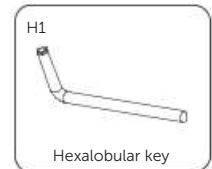
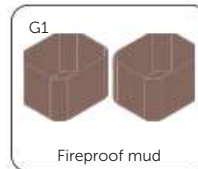
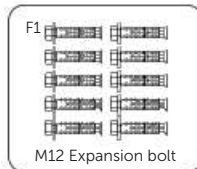
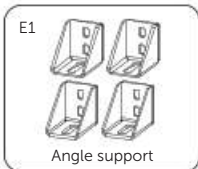
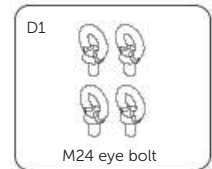
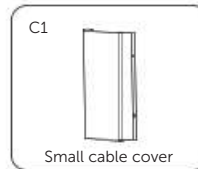
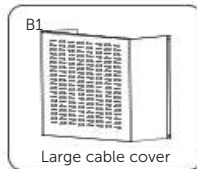
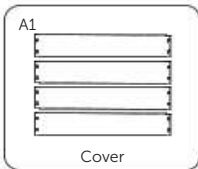

Table 5-1 Packing list

Item No.	Items	Quantity
/	Cabinet	1 pc

Accessory pack



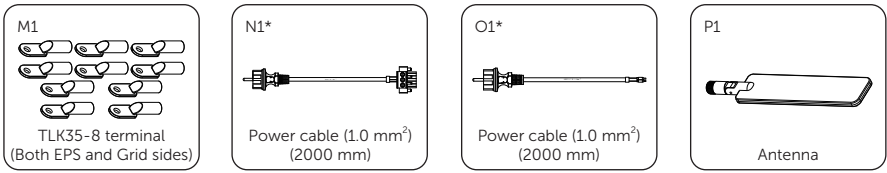

Table 5-2 Packing list

Item No.	Items	Quantity
A1	Cover	4 pcs
B1	Large cable cover	1 pc
C1	Small cable cover	1 pc
D1	M24 eye bolt	4 pcs
E1	Angle support	4 pcs
F1	M12 Expansion bolt	10 pcs
G1	Fireproof mud	2 pcs
H1	Hexalobular key	1 pc
I1	Cable tie	20 pcs
J1	M10*30 Cross screw (for grounding port)	2 pcs
K1	M6*16 Hexalobular socket screw	18 pcs
L1	M12*40 hexagon head screw (for angle support)	8 pcs
M1	TLK35-8 Terminal (Both EPS and Grid sides)	10 pcs
N1*	Power cable (1.0 mm ²) (2000 mm)	1 pc
O1*	Power cable (1.0 mm ²) (2000 mm)	1 pc
P1	Antenna	1 pc

NOTICE!

- The mark "*" indicates that if one of the cables connecting the high-voltage box AC input and AC power is damaged, the power cable (2000 mm) can be used as a replacement cable to connect to the AC input and the power cable (2000 mm) can be used as a replacement cable to connect to the AC power.
- Before installing the cabinet, you should check whether all the accessories and their respective quantities are complete and correct.

Accessory kit for capacity expansion

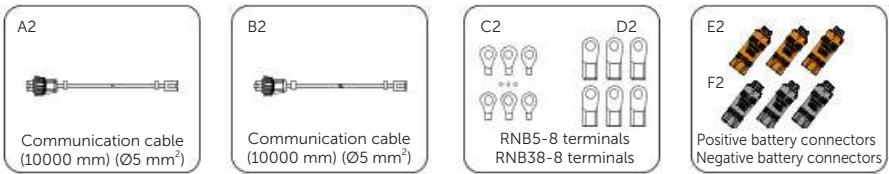

Table 5-3 Packing list

Item No.	Items	Quantity
A2	Communication cable (10000 mm) ($\varnothing 5 \text{ mm}^2$)	1 pc
B2	Communication cable (10000 mm) ($\varnothing 5 \text{ mm}^2$)	1 pc
C2	RNB5-8 terminals	18 pc
D2	RNB38-8 terminals	6 pcs
E2	Positive battery connectors	3 pcs
F2	Negative battery connectors	3 pcs

NOTICE!

- The cable diameter in the above tables refers to the outer diameter.
- For specific capacity expansion wiring steps, please refer to "14.5 Capacity Expansion".

5.2 Inverter Unpacking

5.2.1 Unpacking

- The inverter undergoes 100% testing and inspection before shipping from the manufacturing facility. However, transport damage may still occur. Before unpacking the inverter, please check the outer packing materials for damage, such as holes and cracks.
- Unpacking the inverter according to the following figure.

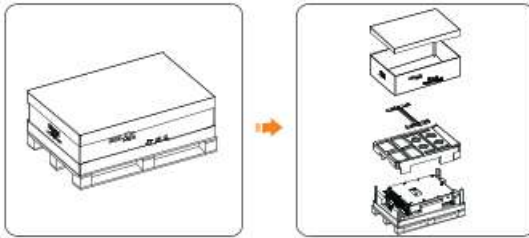











Figure 5-2 Unpacking the inverter

- Be careful when dealing with all package materials which may be reused for storage and relocation of the inverter in the future.
- Upon opening the package, check whether the appearance of the inverter is damaged or lack of accessories. If any damage is found or any parts are missing, contact your dealer immediately.

5.2.2 Packing List

 Inverter	 A3 Mounting bracket	 B3 M5 screws	 C3 Cable clamp
 D3 OT terminal	 E3 RJ45 terminals	 F3 8-pin terminal blocks	 G3 H3 Positive battery connectors Negative battery connectors
 I3 Positive PV connectors & pin contacts	 J3 Negative PV connectors & pin contacts	 K3 M10*100 expansion bolts	 L3 Eye Bolts
 M3 Removal tool for PV connectors	 N3 AC terminals	 O3 P3 AC connector Five-hole sealing plugs	 Q3 R3 M6 flange nuts M4*12 screws
 S3 T3 Negative & positive PV dustproof buckles	 U3 V3 M4*10 screws Inverter screen cover	 W3 X3 RJ45 connector CT	 Y3 Documents
 Meter (optional)	 Dongle (optional)		

* Refer to the actual delivery for the optional accessories.

Table 5-4 Packing list

Item	Description	Quantity
/	Inverter	1 pc

Unpacking and Inspection

Item	Description	Quantity
A3	Mounting bracket	1 pc
B3	M5 screw	4 pcs
C3	Cable clamp	1 pc
D3	OT terminal	1 pc
E3	RJ45 terminal	7 pcs
F3	8-pin terminal block	2 pcs
G3	Positive battery connector	2 pcs
H3	Negative battery connector	2 pcs
I3	Positive PV connector & pin contact	10 pairs for X3-AELIO-50K
J3	Negative PV connector & pin contact	12 pairs for X3-AELIO-60K
K3	M10*100 expansion bolt	4 pcs
L3	Eye bolt	2 pcs
M3	Removal tool for PV connectors	1 pc
N3	AC terminal	10 pcs
O3	AC connector	1 pc
P3	Five-hole sealing plug	2 pcs
Q3	M6 screw	10 pcs
R3	M4*12 screw	2 pcs
S3	Negative PV dustproof buckle	10 pcs for X3-AELIO-50K
T3	Positive PV dustproof buckle	12 pcs for X3-AELIO-60K
U3	M4*10 screws	2 pcs
V3	Inverter screen cover	1 pc
W3	RJ45 connector	1 pc
X3	CT	1 pc
Y3	Documents	/
/	Meter (optional)	1 pc
/	Dongle (optional)	1 pc

6 Mechanical Installation

After determining the installation site, please take out the required underground cables.

WARNING!

- Avoid installing, operating and maintaining the device or cables outdoors under severe weather conditions such as lightning, rain or snow.
- The device must be installed by professionals in accordance with local regulations and standards.
- Before drilling, please check and ensure that the area is free of pipes, light switches, sockets, and wires, and safe to drill into.
- Please wear PPE, and take steps to cover the device to prevent debris from entering it while drilling holes.
- After drilling, clean up the site in time.





CAUTION!

- Pay attention to the weight of the equipment at all times during transportation and installation, improper lifting or dropping of the equipment may cause personal injury.

6.1 Battery Cabinet Installation Dimensions

Angle supports installed at front and rear sides

Unit: mm

-  Installation position for eye bolt
-  Fork position,
-  Angle support
-  Foundation

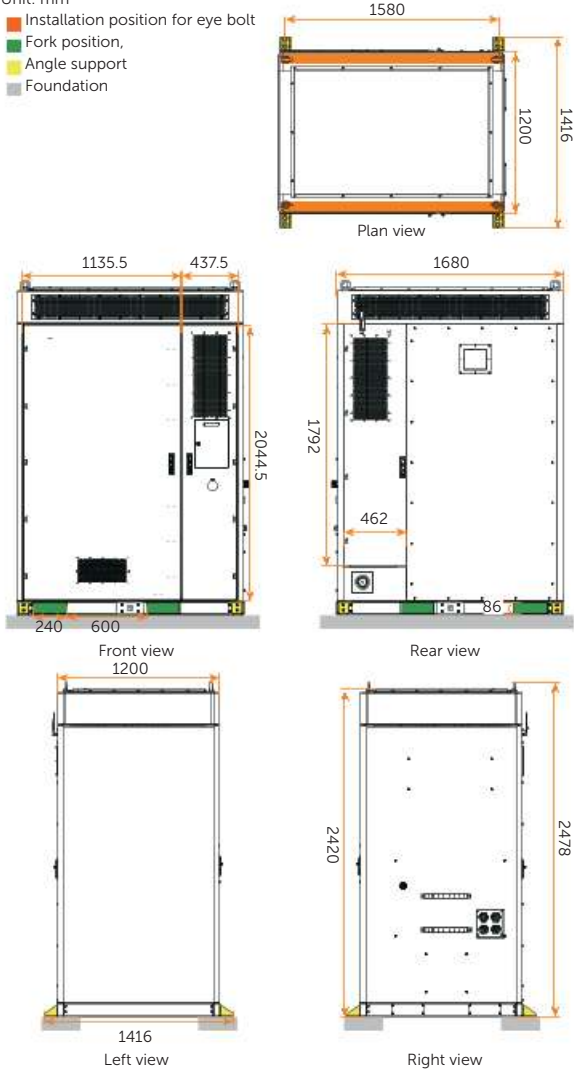

Figure 6-1 Dimension of battery cabinet

Angle supports installed at left and right sides

Unit: mm

- Installation position for eye bolt
- Fork position
- Angle support
- Foundation

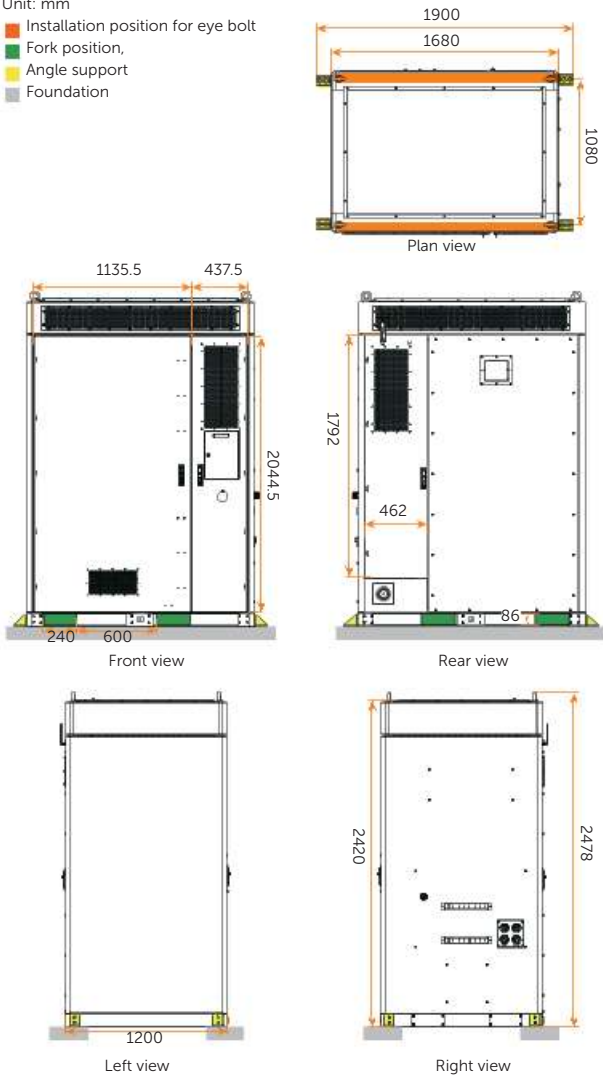

Figure 6-2 Dimension of battery cabinet

6.2 Battery Cabinet Handling

NOTICE!

- There are two ways to move a cabinet: using a crane or a forklift. Please refer to “3.1.1 Battery Cabinet Transportation” for related handling precautions.

6.2.1 Hoisting

NOTICE!

When hoisting:

- Temporary warning signs or fences should be set up in the hoisting area, and only the qualified persons can access it.
- Never stand and walk under or near the device being lifted or lowered.
- For safety reasons, avoid long-distance hoisting operations.
- Please be careful when hoisting and placing the device, and do not remove the ropes before it is seated on the foundation. Please make sure that the boom lift moves level and the cabinet's tilt angle is $\leq 5^\circ$ during hoisting.
- The angle in both the diagonal ropes shall be $\leq 60^\circ$.
- Do not lift the next one before the previous cabinet has been installed on the foundation.

Installation of eye bolt

Step 1: Remove the M24 screws (with a total of 4 pieces) inside the top eye bolt holes using a torque wrench.

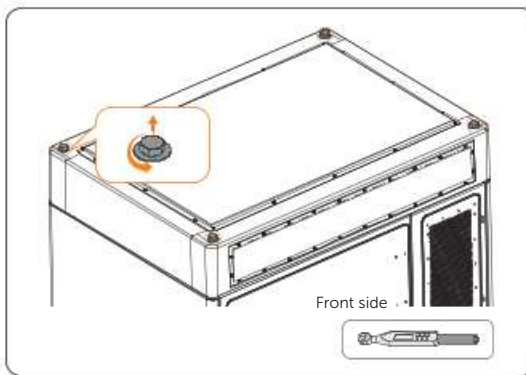

Figure 6-1 Unscrewing M24 screws

Step 2: Insert and clockwise the M24 eye bolts (part G) through a steel pipe. There are a total of 4 pieces of eye bolts shall be installed.

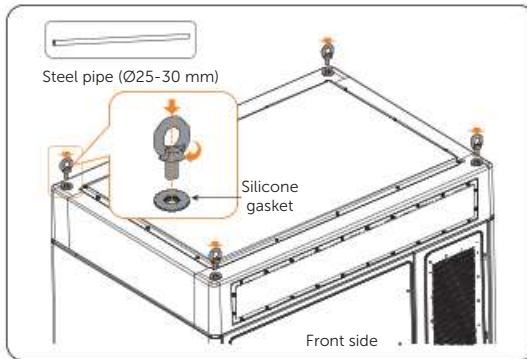

Figure 6-2 Tightening eye bolts

NOTICE!

- Put the silicone gaskets in place before inserting the eye bolts.
- Please ensure that the eye bolt's shoulder makes total contact with the silicone gasket.

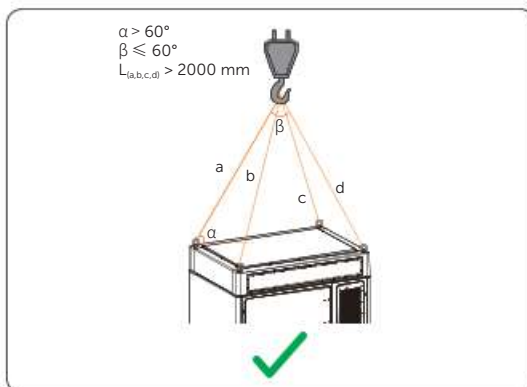

Figure 6-3 Proper way of hoisting

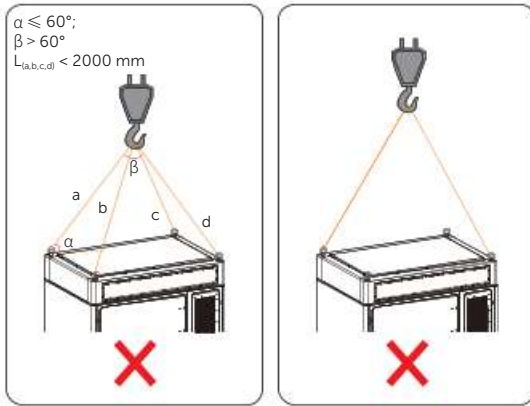

Figure 6-4 Improper way of hoisting

NOTICE!

- It is not recommended to use other hoisting methods which are not written in the user manual.
- Before lifting, please prepare sufficient length of lifting ropes according to the actual situation.
- L=Length

6.2.2 Forklift

NOTICE!

- When using a forklift to move the cabinet, please secure it according to the actual situation to ensure that the cabinet does not pose a risk of tipping over.

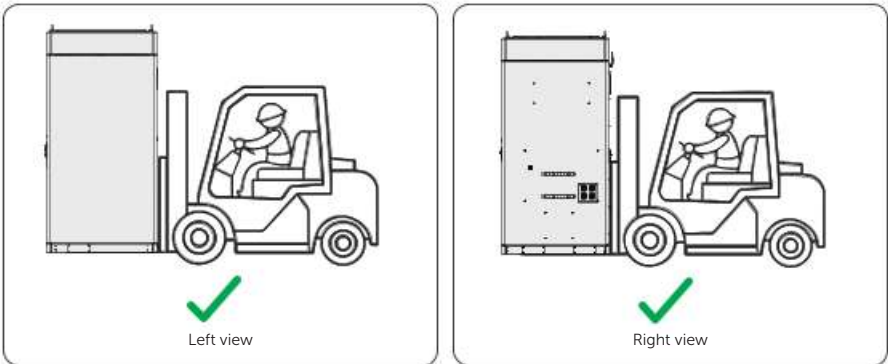

Figure 6-5 Right positions

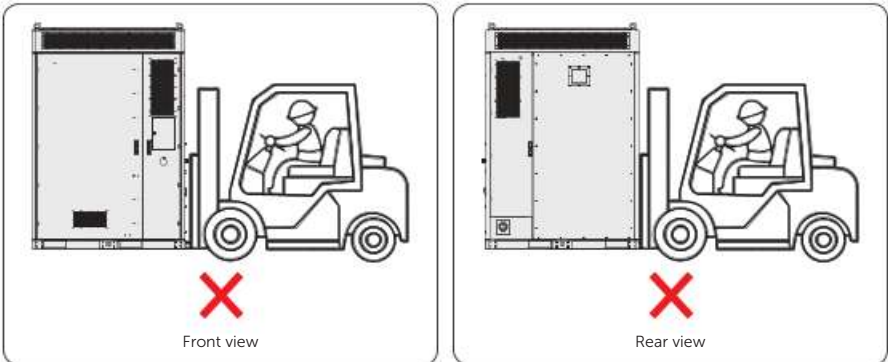

Figure 6-6 Wrong positions

NOTICE!

- For installation space requirements, please refer to "4.1.2 Clearance Requirement".
- For foundation requirements, please refer to "4.1.1 Installation Foundation Requirements".

6.3 Installation Procedure for Angle Support and Cover

The cabinet allows the angle supports to be installed at the front and-rear sides or at the left and-right sides. Since the installation procedure for the angle support is the same, take the angle support installed at the front and-rear sides, for instance.

Step 1: After determining the installation position of the cabinet, attach the angle supports (part E1) to the cabinet and draw a circle on the bottom of the angle support. The distance between two holes should be: $40\text{ mm} \leq D < 50\text{ mm}$. There are totalling 4 angle supports for a cabinet.



Figure 6-7 Installation position

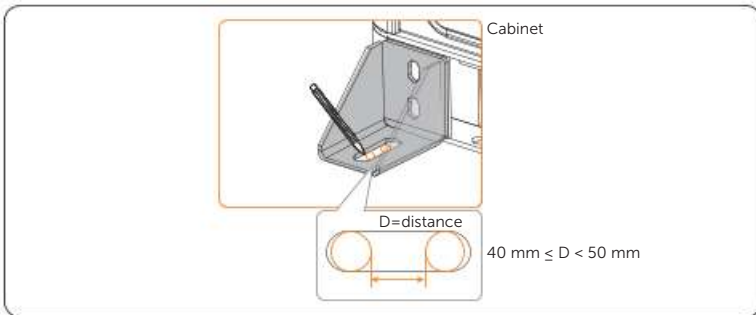

Figure 6-8 Marking hole position

Step 2: Drill holes at the previously marked positions (drill bit: $\text{\O}18$ mm; hole depth: 95~105 mm). After drilling, clean the foundation surface with a vacuum cleaner.

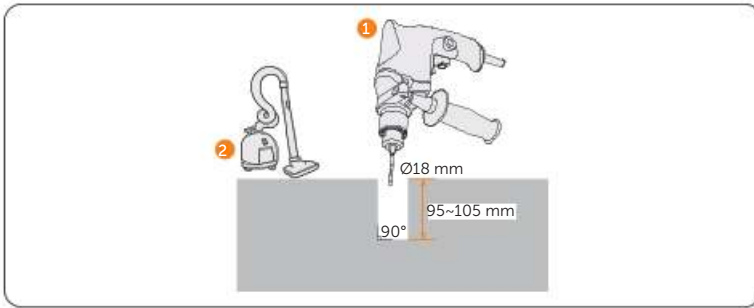

Figure 6-9 Drilling

Step 3: Reattach the angle supports to the cabinet, and insert M12 screws (part L1) and tighten them clockwise using a torque wrench (torque: 42 ± 4.2 N·m). Each angle support has two screws, with a total of four angle supports.

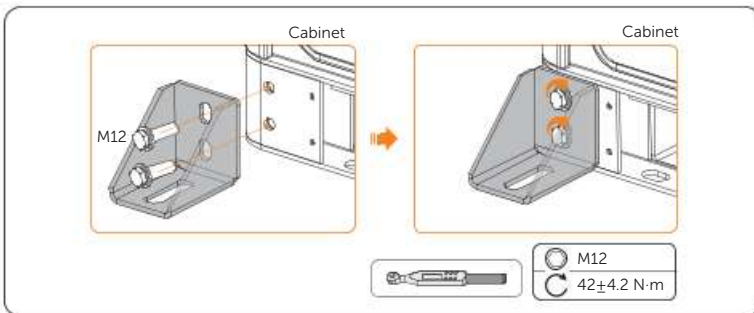

Figure 6-10 Tightening M12 screws

NOTICE!

- Reinstall the angle supports, ensuring that the screw holes on the angle support align with the screw holes on the cabinet and foundation.

Step 4: Use a rubber hammer to drive the M12 expansion bolts (part F1) into the foundation screw holes, and then tighten them clockwise with a torque wrench (M12) (torque: 42 ± 4.2 N·m). Each angle support has 2 expansion bolts, with a total of 8 expansion bolts.

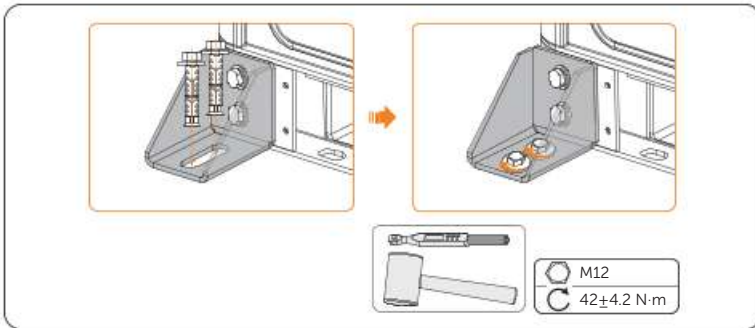

Figure 6-11 Tightening expansion bolts

Step 5: After the angle supports have been installed, take out the covers (part A1) to seal the forklift hole and tighten the M6 hexalobular screws (part K1) with the hexalobular key (part H1). Each cover has 4 screws, with a total of 4 covers.

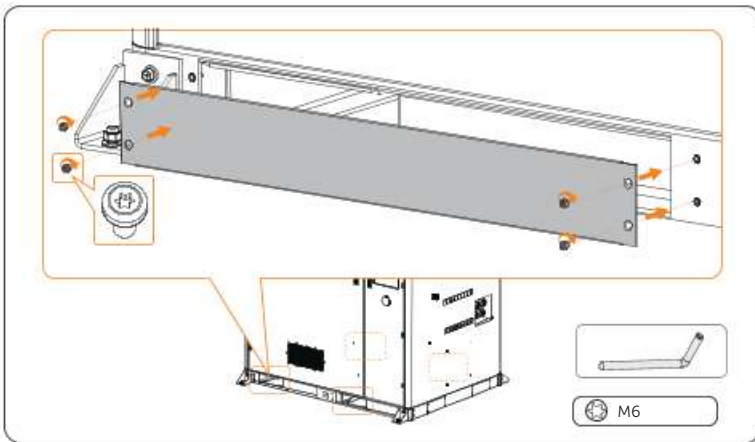

Figure 6-12 Fixed covers

NOTICE!

- The above-mentioned installation steps also apply to the angle supports, which are installed on both the left and right sides.

6.4 Antenna Installation

NOTICE!

- The user can decide whether the reserved port connects an antenna based on the actual situation.
- Regarding the other antenna port, the antenna is delivered with the accessories kit.

There are two antenna ports on the rear side of the cabinet. The left one shall be connected to an antenna, and the right one is a reserved port. Regarding the antenna installation steps, please do as follows.

Step 1: Remove the silicone cap.

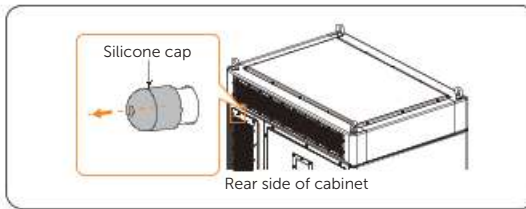

Figure 6-13 Removing silicone cap

Step 2: Correctly insert and tighten the antenna (part P1) by turning it clockwise.

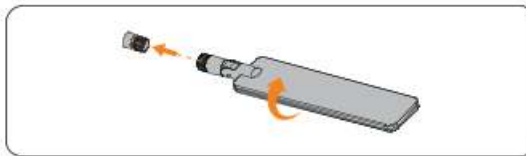

Figure 6-14 Installing antenna

Step 3: Fold the antenna up 90°.

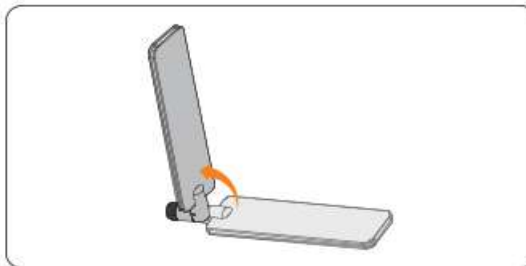

Figure 6-15 Folding the antenna

After installing the antenna, see following figure.

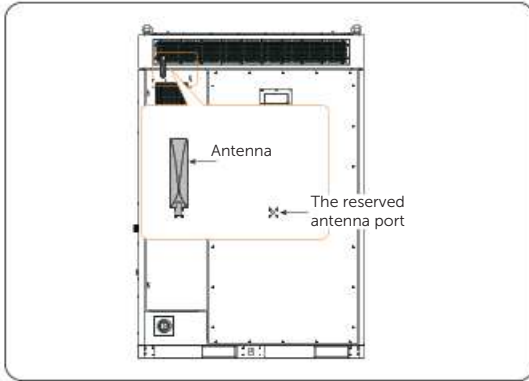

Figure 6-16 Installing an antenna

6.5 Smoke Detector and Temperature Sensor Covers Removal

A cover has been fitted on the temperature sensor and smoke detector, respectively, at the factory. Therefore, the please remove covers before using them.

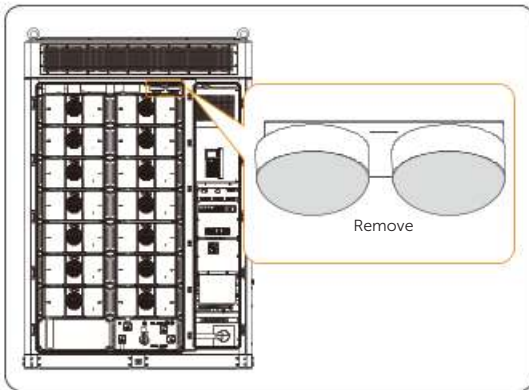

Figure 6-17 Removing smoke detector and temperature sensor covers

6.6 Inverter Installation

WARNING!

- Only the qualified personnel can perform the mechanical installation following the local standards and requirements.

CAUTION!

- Always be aware of the weight of the inverter. Personal injuries may result if the inverter is lifted improperly or dropped while being transported or mounted.
- Use insulated tools when installing the inverter. Personal protective equipment must be worn during installation and maintenance.

NOTICE!

- Install the inverter at a maximum back tilt of 5 degrees and avoid forward tilted, side tilted, or upside down.

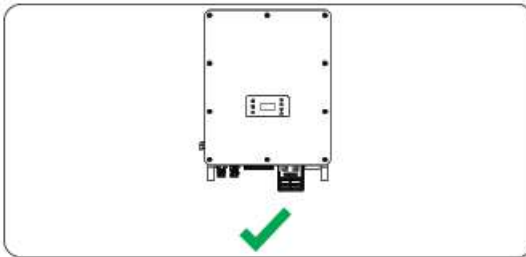

Figure 6-18 Correct installation

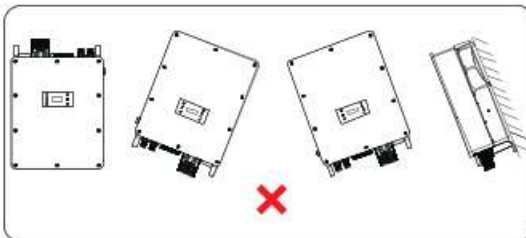

Figure 6-19 Incorrect installation

6.6.1 Inverter Installation Dimensions

Check the dimensions of the wall mounting bracket before mounting and reserve sufficient space for heat dissipation and installation of the whole system.

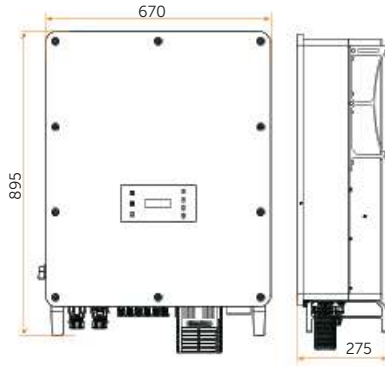

Figure 6-20 Dimensions (Unit: mm)

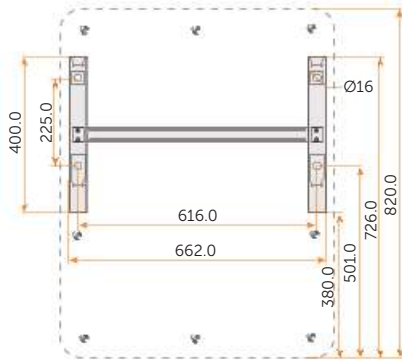

Figure 6-21 Dimensions 2 (Unit: mm)

6.6.2 Installation Procedures

Step 1: Confirm the four holes for the position of the mounting bracket on the battery cabinet.

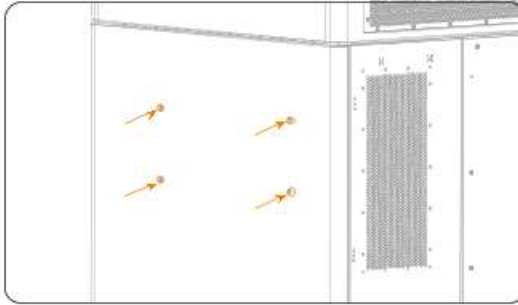

Figure 6-22 Confirming the position of the mounting bracket

Step 2: Take out the mounting bracket (part A3) from the carton. Attach the mounting bracket on the battery cabinet. Knock the expansion screws (part E3) into the holes and secure it to the cabinet by torque wrench. (Torque: 24 N·m)

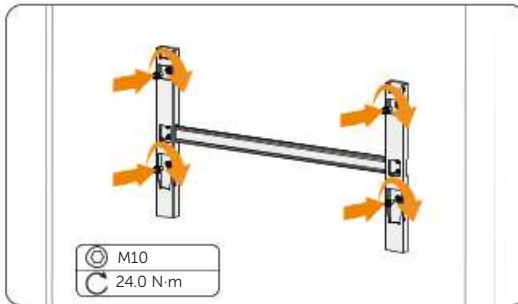

Figure 6-23 Securing the mounting bracket

Step 3: Open the anti-static bag and take out the machine.

NOTICE!

- If the inverter is temporarily needed to be placed on the ground, use foam or other protective materials to prevent any damage to the inverter.

Step 4: Remove the carton, pull out the plugs on the sides of the inverter. Tighten the two eye bolts (part L3) on the two sides of the inverter and tie them with a sling. Lift up the inverter with a crane and hang the device on the mounting bracket. The keyways of the inverter must be hooked into the buckles of the mounting bracket.

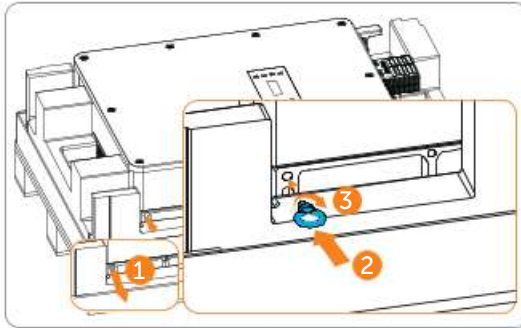

Figure 6-24 Installing the eye bolts

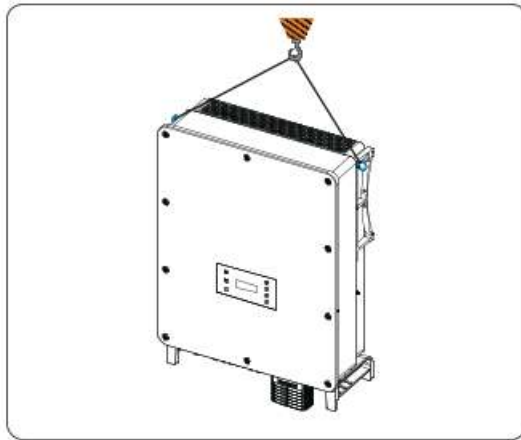

Figure 6-25 Hanging the inverter

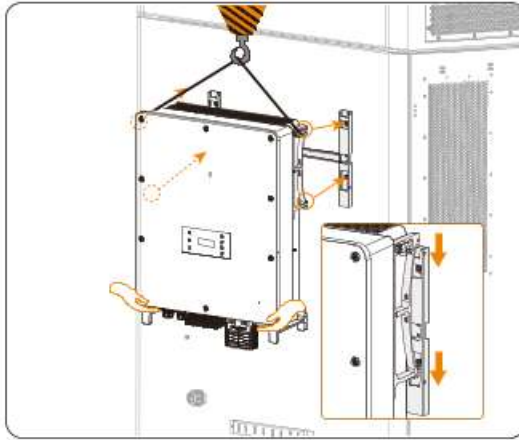

Figure 6-26 Hooking the inverter on the bracket

NOTICE!

- When the inverter is lifted up from the carton or the inverter is close to the mounting bracket, use hands to adjust the inverter position to prevent any damage to the inverter.
- Ladders will be helpful for installers to stand in a proper position and adjust the inverter position.

Step 5: Remove the eye bolts when the inverter is hooked on the mounting bracket and put the plug back in.

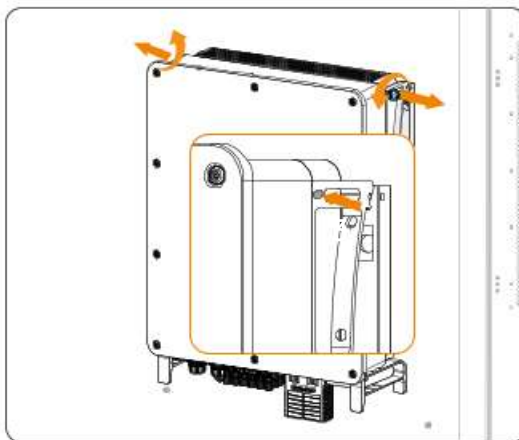

Figure 6-27 Removing the eye bolts

NOTICE!

- After removing the eye bolts from the inverter, keep them in a safe place. They are needed when the inverter is relocated or disassembled.

Step 6: Secure the inverter to the mounting bracket with M5 screws (part B3). (Torque: 3 ± 0.3 N·m)



Figure 6-28 Securing the inverter

7 Electrical Connection

NOTICE!

- Before wiring, operators are required to learn which parts need to be conducted wiring. For details, please refer to Figure 7-1.

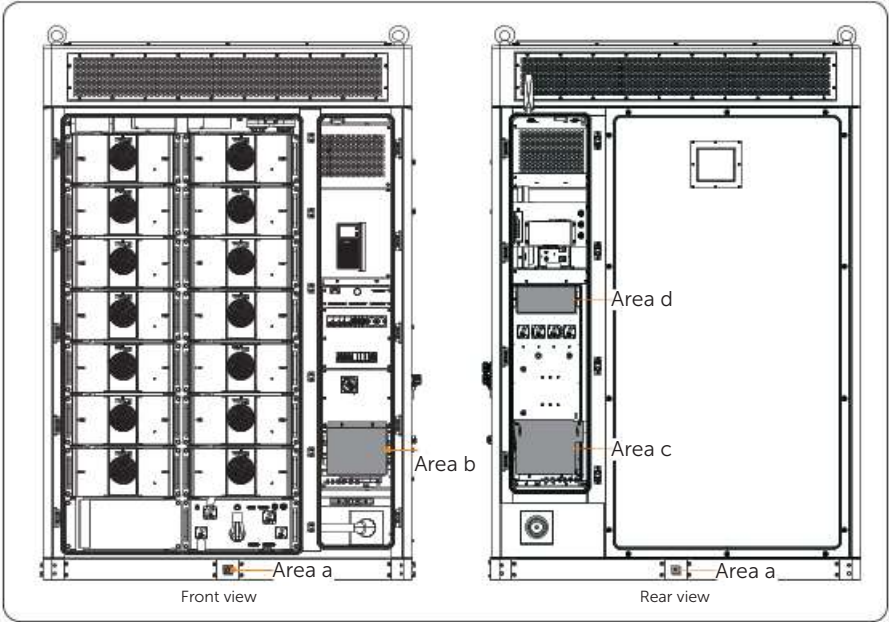

Figure 7-1 Wiring area

Table 7-1 Introduction of wiring area

Wiring area	Description
Area a	To connect grounding plate or PE wire.
Area b	To connect EPS wires.
Area c	To connect GRID wires.
Area d	To connect cables for parallel connection.

7.1 Cabinet Grounding Connection

The device supports grounding plate connection and PE connection. Either of them can be connected to the wiring area "Area a". Please strictly follow the steps below.

NOTICE!

- There are two GND ports on the cabinet. Either of them can be connected.
- The grounding plate or the PE wire is prepared by the user self. For details, please refer to "4.3 Additionally Required Materials".

Grounding Plate Connection

Step 1: Insert and tighten M10 screw (part J1) to secure grounding plate (torque: 24 ± 2 N·m).

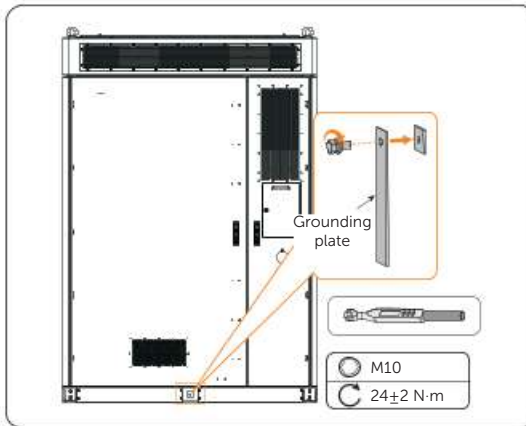

Figure 7-2 Tightening M10 screws

PE Connection

Step 1: Strip the cable jacket about 20 mm from the end.

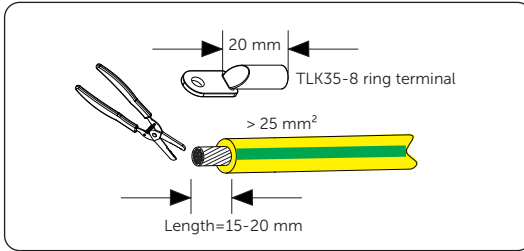

Figure 7-3 Stripping cable jacket

Step 2: Cut the heat-shrink tubing (Ø15-20 mm) to about a length of 30 mm to 40 mm, carefully slide it onto the end of the cable, and then carefully slip the wires all the way into the grounding terminal (part M1).

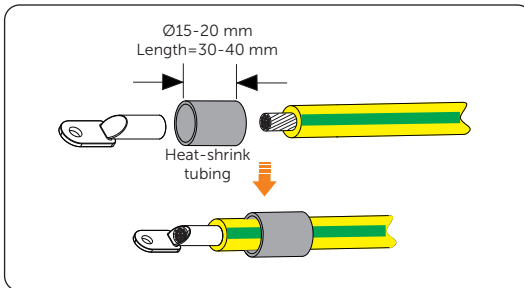

Figure 7-4 Cutting heat-shrink tubing

Step 3: Crimp the terminal, and heat the heat-shrink tubing after it wraps the end of terminal.

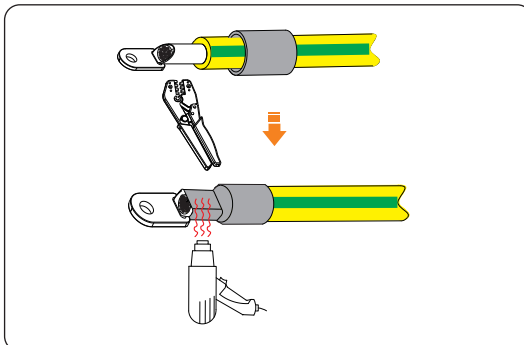

Figure 7-5 Crimping and heating

Step 4: Connect the assembled grounding cable to the grounding port of the cabinet, and then tighten M10 screw (part J1) (torque: 24 ± 2 N·m).

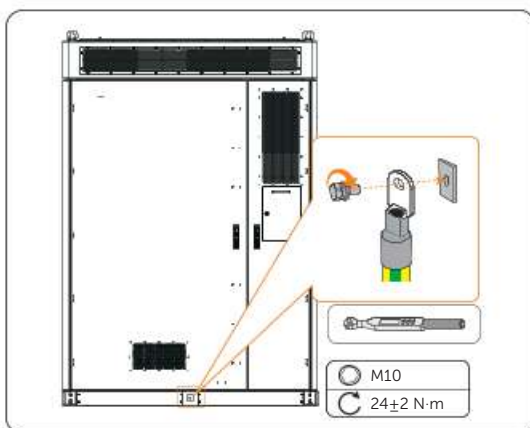

Figure 7-6 Tightening M10 screw

7.2 Inverter Electrical Connection

DANGER!

- Before electrical connection, make sure the DC switches and AC breakers are disconnected. Otherwise, electrical shock may be caused by high voltage, resulting in serious personal injury or death.

WARNING!

- Only the qualified personnel can perform the electrical connection following the local standards and requirements.
- Follow this manual or other related document to wire connection. The inverter damage caused by incorrect cabling is not in the scope of warranty.
- Use insulated tools and wear personal protective equipment throughout the electrical connection process.

NOTICE!

- The Grid cable, EPS cable, battery cables, COM1 (EMS and BMS1) communication cables of the inverter are prefabricated in the battery cabinet, the cable outlets as shown below:

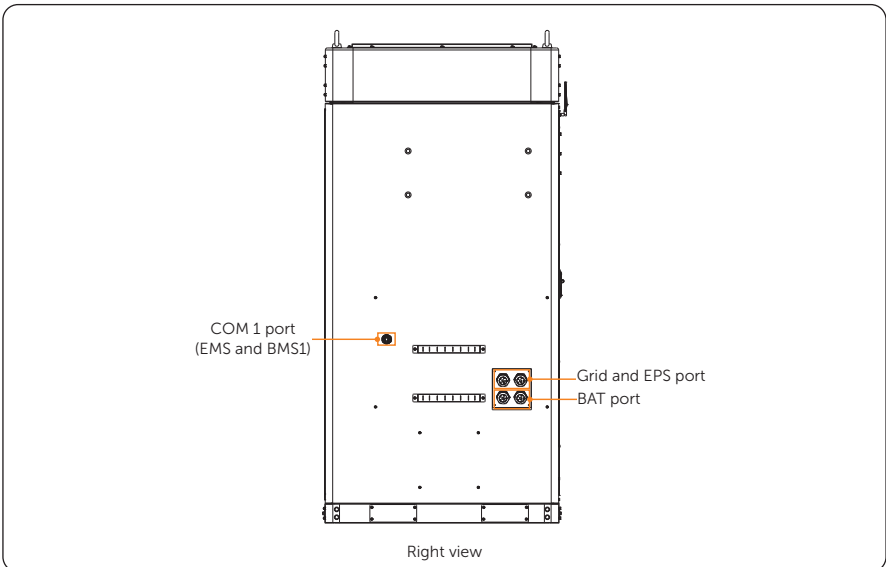

Figure 7-7 Prefabricated inverter cables in battery cabinet

7.2.1 Terminals of Inverter

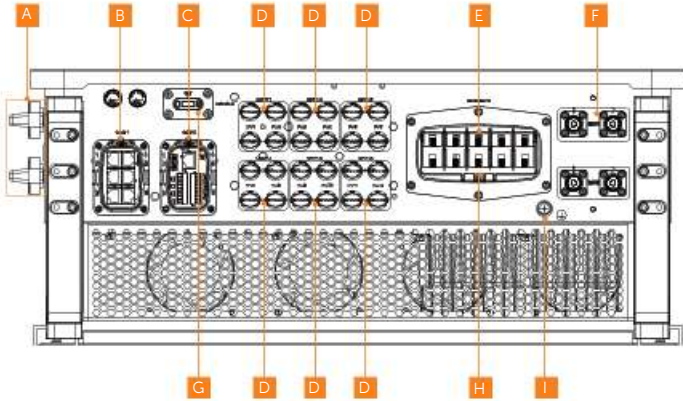

Figure 7-8 Terminals of Inverter

Table 7-1 Description of terminals

Item	Description	Decisive voltage class
A	DC switch (including DC switch 1 and DC switch 2)	-
B	COM 1 communication terminal (including Parallel-1, Parallel-2, BMS-1, BMS-2, RS485, DRM)	DVC-A
C	COM 2 communication terminal (including Ripple control, DIO, Meter/CT)	DVC-A
D	PV connection terminal (PV1~PV5 terminals for X3-AELIO-50K; PV1~PV6 terminals for X3-AELIO-60K)	DVC-C
E	EPS connection terminal	DVC-C
F	Battery connection terminal (including BAT 1 and BAT 2)	DVC-C
G	Dongle terminal	DVC-A
H	Grid connection terminal	DVC-C
I	Ground connection point	-

7.2.2 AC Connection

NOTICE!

- Before connecting the inverter to the grid, approval must be received by local utility as required by national and state interconnection regulations.

The inverter has an EPS function. When the grid is connected, the inverter outputs go through the Grid terminal, and when the grid is disconnected, the inverter outputs go through the EPS terminal.

Requirements for AC connection

- Grid voltage requirement
 - » The grid voltage must be within the permissible range. The inverter is suitable for rated voltage 400V/230V, 380/220V, frequency 50/60Hz. Other technical requests should comply with the requirement of the local public grid.
- RCD requirement
 - » The inverter does not require an external residual-current device when operating. If an external RCD is required by local regulations, it is recommended to use a Type-A RCD with the value of 300 mA. When required by local regulations, the use of an RCD type B is permitted.
- AC breaker requirement
 - » An AC breaker that matches the power of the inverter must be connected between the inverter output and the power grid, and each inverter must be equipped with an independent breaker or other load disconnection unit to ensure the safe disconnection from the grid. Refer to "[4.3 Additionally Required Materials](#)" for specific data of AC breaker of Grid and EPS.
- Load requirement
 - » It is prohibited to connect any load between inverter and AC switch that directly connects to the inverter.
- EPS load requirement
 - » Do not connect sensitive precision instruments or medical device to the EPS terminal.
 - » Ensure that the EPS load rated power is within the EPS rated output power range. Otherwise, the inverter will report an **Overload Fault** warning. When **Overload Fault** occurs, turn off some loads to make sure it is within the EPS rated output power range, and the inverter will return to normal after **ESC** key on the LCD screen pressed.
 - » For inductive load such as fridge, air conditioner, washing machine, etc., ensure that the start power does not exceed the EPS peak power.

Table 7-2 EPS load information

Type of load	Device	Start power
Resistive load	Lamp	Equal to rated power
	Fan	Equal to rated power
	Hairdryer	Equal to rated power
	Fridge	3-5 times rated power
Inductive load	Air conditioner	3-6 times rated power
	Washing machine	3-5 times rated power
	Microwave oven	3-5 times rated power

* Please refer to the nominal current of the device for the actual start current.

Wiring procedures

NOTICE!

The Grid and EPS cables of the inverter outlet from the **Grid and EPS port** in "Figure 7-7 Prefabricated inverter cables in battery cabinet", please strictly follow the steps below.

Step 1: Anti-clockwise loosen the swivel nut and pull out the sealing plugs to disassemble the AC connector (part O3) as below. Keep the sealing plugs still in the cable support sleeve if you choose not to connect the cable. Replace the original sealing plugs with the five-hole sealing plugs (part P3).



Figure 7-9 Disassembling the AC connector

Step 2: Thread the Grid and EPS cable through the AC connector.

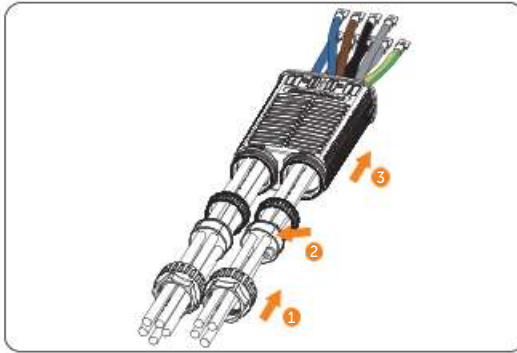

Figure 7-10 Threading cables through the AC connector

Step 3: Secure the L1, L2, L3, N and grounding conductors of the assembled Grid cable with M6 screws. (Torque: 5.0 ± 1.0 N·m) Make sure the conductors are correctly assigned and firmly seated in the terminals.

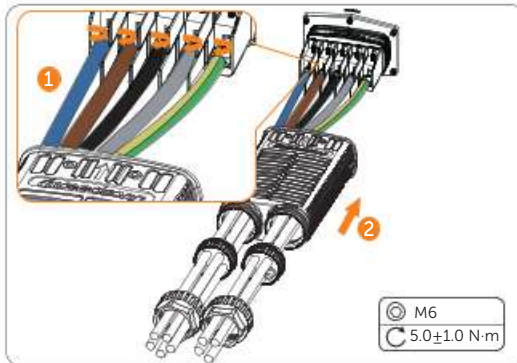

Figure 7-11 Connecting the Grid cable

Step 4: Secure the L1, L2, L3, N conductors of the assembled EPS cable with M6 screws (part Q3). (Torque: 5.0 ± 1.0 N·m) Make sure the conductors are correctly assigned and firmly seated in the terminals. Connect the enclosure of the AC connector to the inverter, insert the waterproof seals into the AC connector, and tighten the swivel nuts of the connector.

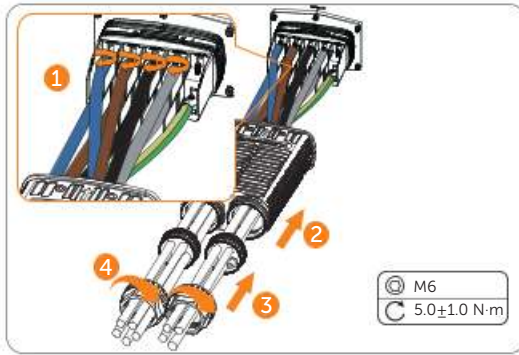

Figure 7-12 Connecting the EPS cable

Step 5: Connect the assembled AC connector to the AC port of the inverter, tighten the two M4*12 screws (part R2) on the AC connector enclosure (Torque: 1.6 ± 0.1 N·m) and tighten the swivel nuts clockwise.

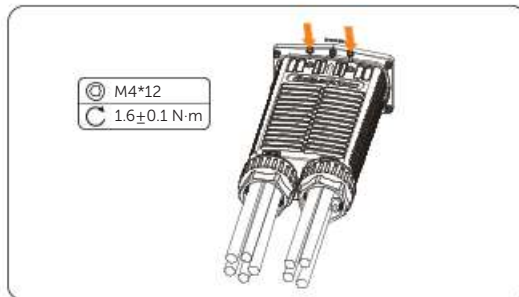

Figure 7-13 Securing the AC connector on the inverter

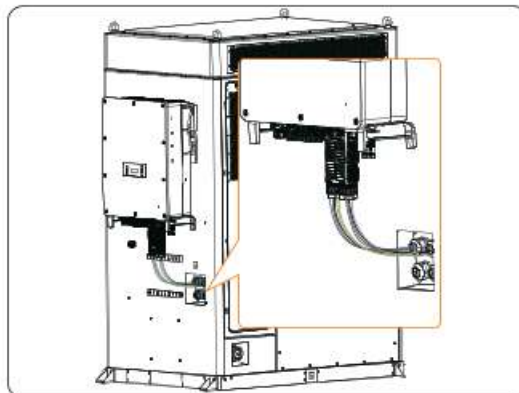

Figure 7-14 Well connected AC connector

 DANGER!

- Before powering on the inverter, make sure the AC connector has been installed correctly on the Grid and EPS terminal even if the EPS terminal is not wired. Otherwise, electrical shock may be caused by high voltage, resulting in serious personal injury or death.

 WARNING!

- Reinstall AC terminal caps immediately after removing the connectors from terminals.

7.2.3 PV Connection

 DANGER!

- High DC voltage will be generated by PV modules when exposed to sunlight. Death or lethal injuries will occur due to electric shock.
- Make sure the DC switch and AC breaker are disconnected from the inverter before connection.
- Make sure that the PV module output is well insulated to ground.

 CAUTION!

- Power is fed from more than one source and more than one live circuit.

Requirements for PV connection

- Open circuit voltage and working voltage
 - » The open circuit voltage of the module array should be less than the maximum PV input voltage (1000 V) of the inverter. Otherwise the inverter may be damaged.
 - » The working voltage should be within the MPPT voltage range (160-950 V). Otherwise, the inverter will prompt **PV Volt Fault**. Consider the impact of low temperature on the voltage of the photovoltaic panels, as lower temperatures tend to result in higher voltages.
 - » The working voltage should be within the full load MPPT range (320-800V). Otherwise, the inverter will prompt derating protection.
- PV module
 - » The PV modules within the same MPPT channel are of the same brand. Additionally, the strings within the same channel should have identical quantities, and be aligned and tilted identically.

- » The positive or negative pole of the PV modules is not grounded.
- » The positive cables of the PV modules must be connected with positive DC connectors.
- » The negative cables of the PV modules must be connected with negative DC connectors.

Wiring procedures

Step 1: Strip approx. 7 mm of the cable insulation.

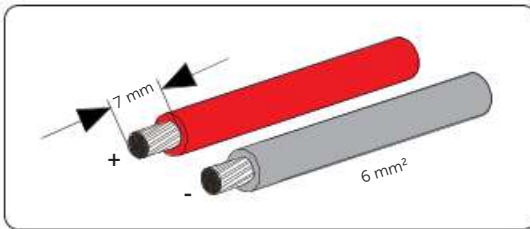

Figure 7-15 Stripping the PV cable

Step 2: Insert the stripped cable into the PV pin contact (part I3 and Part J3). Ensure that the stripped cable and the PV pin contact are of the same polarity. Crimp it with a crimping tool for PV terminal.

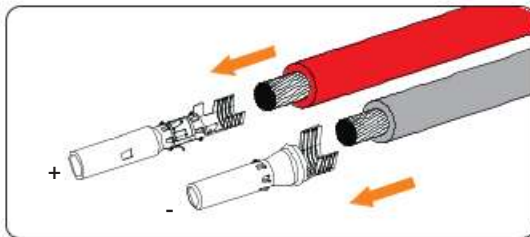

Figure 7-16 Inserting the PV pin contact

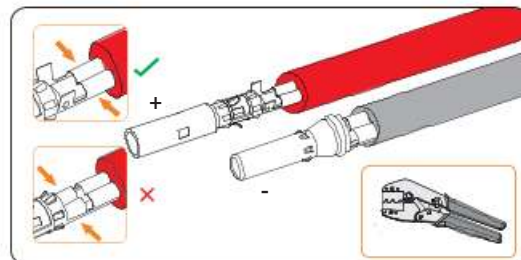

Figure 7-17 Crimping the terminal

 **WARNING!**

- To mitigate the risk of fire, it is crucial to utilize a dedicated crimping tool specifically designed for PV installations to ensure secure and reliable connections.

Step 3: Thread the PV cable through the swivel nut and insert the cable into the PV connector until a "Click" is heard. Gently pull the cable backward to ensure a firm connection. Tighten the swivel nut clockwise. Verify that the PV connectors have the correct polarity before connection.

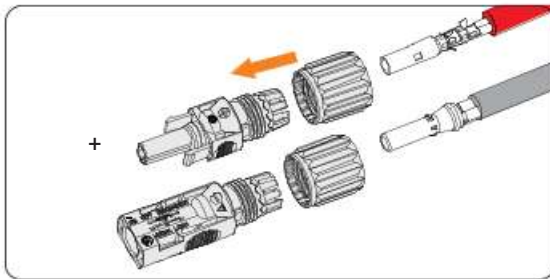

Figure 7-18 Threading the PV cable

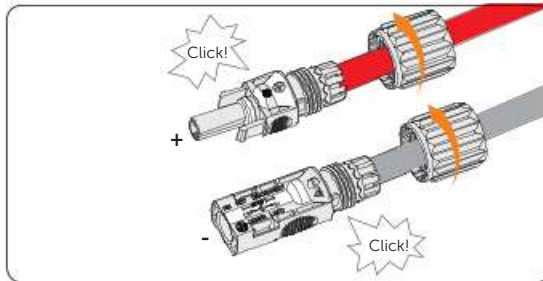

Figure 7-19 Securing the PV cable

Step 4: Use a multimeter to measure the positive and negative voltage of the assembled PV connectors. Make sure the open circuit voltage does not exceed the input limit of 1000 V.

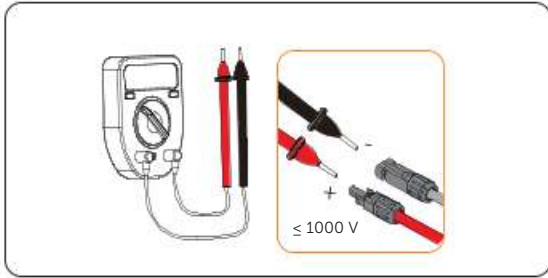

Figure 7-20 Measuring the voltage of PV connectors

NOTICE!

- If the voltage reading is negative, it indicates an incorrect DC input polarity. Please check if the wiring connections on the multimeter is correct or PV connectors are not mistakenly connected.

Step 5: Remove the PV terminal caps and connect the assembled PV connectors to corresponding terminals until there is an audible "Click". The PV+ on the string side must be connected to the PV+ on the inverter side, and the PV- on the string side must be connected to the PV- on the inverter side.

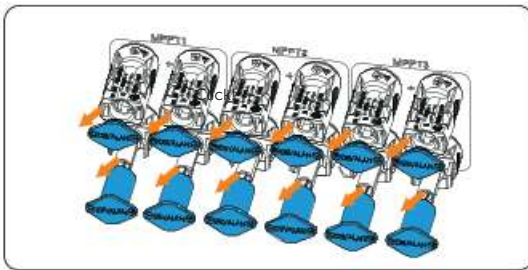

Figure 7-21 Connecting the PV cable

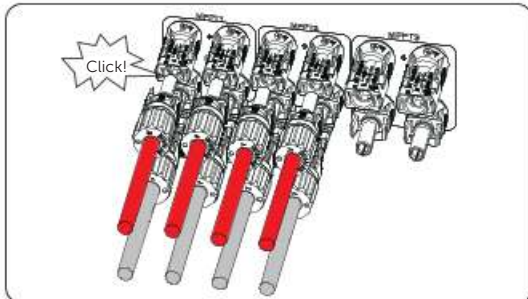

Figure 7-22 Connecting assembled PV cables to the inverter

- Step 6:** Seal the unused positive and negative PV terminals with corresponding PV dustproof buckles (part S3 and Part T3). Reinstall them immediately after removing the connectors from terminals.

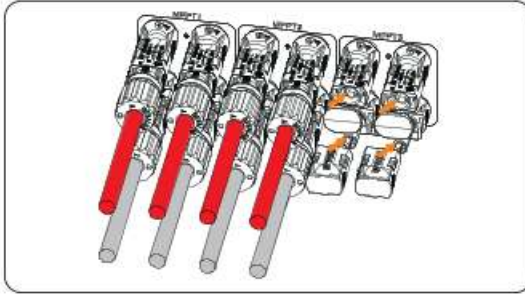

Figure 7-23 Installing PV dustproof buckles

- Step 7:** Secure the PV cables to the bracket with cable ties.

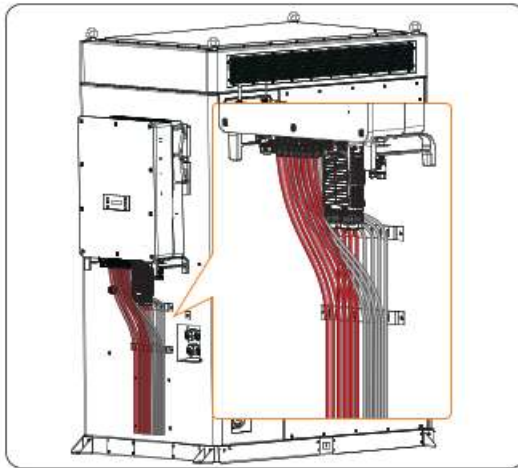

Figure 7-24 Well connected PV cables

7.2.4 Battery Power Cable Connection



- Make sure the breaker of battery is in OFF position.
- Always ensure correct polarity. Never reverse the polarity of the battery cables as this will result in inverter damage.

Requirements for battery connection

- Required battery
 - » The inverter is equipped with two independent battery terminals, allowing for connection to two battery cabinets. Max charge and discharge current is 160 (80*2) A for each BAT terminal.
 - » Make sure the input voltage of each BAT terminal is higher than minimum voltage 180 V and lower than maximum input voltage 820 V.
- Micro circuit breaker (MCB)
 - » If local regulations mandate the use of a DC MCB between the battery and the inverter, install a non-polar DC MCB.
 - » Nominal voltage of DC MCB should be larger than maximum voltage of battery.

Wiring procedures

NOTICE!

- The Grid and EPS cables of the inverter outlet from the Grid and EPS port in “[Figure 7-7 Prefabricated inverter cables in battery cabinet](#)”, please strictly follow the steps below.
- When the battery capacity requires expansion, BAT2 can be connected to AELIO-B100 or AELIO-B200 battery cabinets with the same wiring method.

Step 1: Loosen the screws on the battery protective cover and remove the cover. Pull out the battery caps.

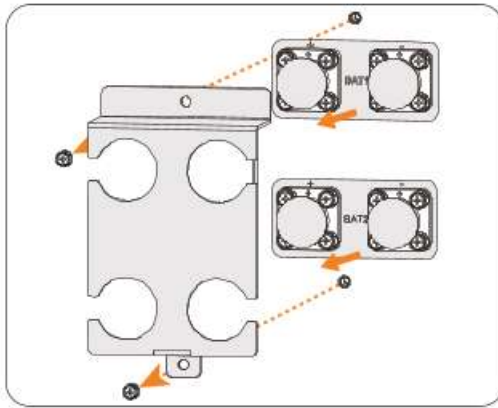

Figure 7-25 Removing the battery protective cover

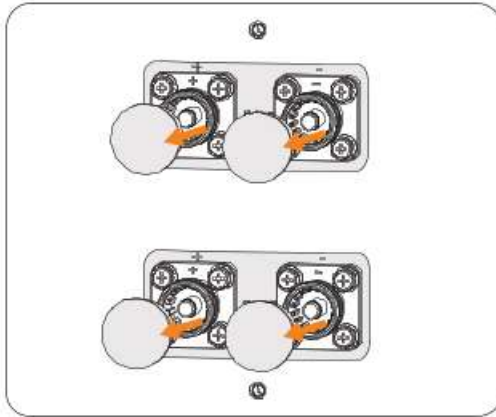

Figure 7-26 Removing battery caps

- Step 2:** Connect the battery connectors to corresponding terminals until there is an audible "Click". The BAT+ on the string side must be connected to the BAT+ on the inverter side, and the BAT- on the string side must be connected to the BAT- on the inverter side. Gently pull the cable backward to ensure firm connection.

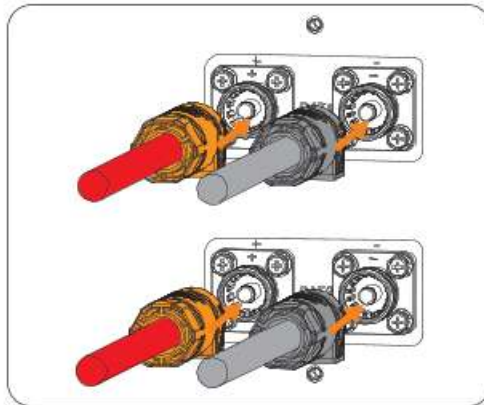

Figure 7-27 Connecting assembled battery cables

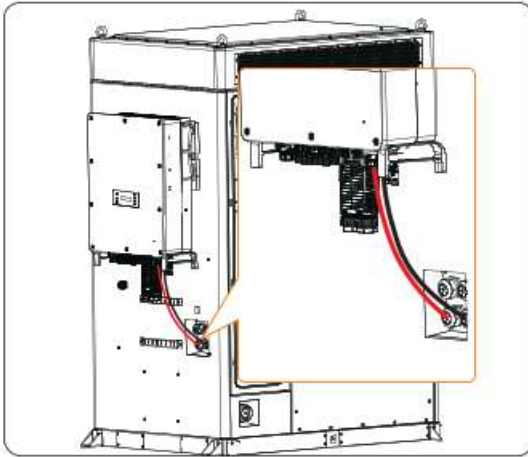

Figure 7-28 Well connected battery cables

 **WARNING!**

- Seal the unused battery terminals with original terminal caps.
- Keep the terminal caps in a safe place if battery cables are connected to the inverter.
- Reinstall it immediately after removing the connectors from terminals.

7.2.5 COM 1 Communication Connection

Pin assignment of COM 1 terminal

The COM 1 terminal is used for cabinet and inverter communication via PARALLEL-1 communication terminal, parallel connection and via PARALLEL-1 and PARALLEL-2 communication terminal, battery communication via BMS-1 and BMS-2 terminal, external device communication via RS485 and DRM function.

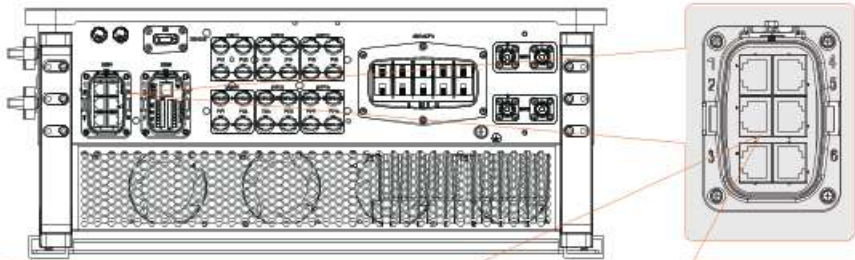

PARALLEL 1
 1: PARALLEL_485A
 2: PARALLEL_485B
 3: DATA_BUS
 4: PARALLEL_CANH
 5: PARALLEL_CANL
 6: GND_COM
 7: PARALLEL_SYNC1
 8: PARALLEL_SYNC2



PARALLEL 2
 1: PARALLEL_485A
 2: PARALLEL_485B
 3: DATA_BUS
 4: PARALLEL_CANH
 5: PARALLEL_CANL
 6: GND_COM
 7: PARALLEL_SYNC1
 8: PARALLEL_SYNC2



BMS1
 1: BAT_TEMP
 2: GND_COM
 3: GND_COM
 4: BMS1_CANH
 5: BMS1_CANL
 6: BAT_WAKEUP_POWER
 7: BMS1_485A
 8: BMS1_485B



BMS2
 1: BAT_TEMP
 2: GND_COM
 3: GND_COM
 4: BMS2_CANH
 5: BMS2_CANL
 6: BAT_WAKEUP_POWER
 7: BMS2_485A
 8: BMS2_485B



RS485
 1: REMOTE_485A
 2: REMOTE_485B
 3: NC
 4: PARALLEL_485AA
 5: PARALLEL_485BB
 6: NC
 7: REMOTE_485A
 8: REMOTE_485B



DRM
 1: DRM1/5
 2: DRM2/6
 3: DRM3/7
 4: DRM4/8
 5: +3.3V_COM
 6: COM/DRM0
 7: GND_COM
 8: GND_COM



NOTICE!

The COM 1 cables of the inverter outlet from the **COM 1 port** in “Figure 7-7 Prefabricated inverter cables in battery cabinet”, please strictly follow the steps below.

Cabinet and inverter communication and parallel communication connection

The inverter provides the parallel connection function. One inverter will be set as the “Master inverter” to control the other “Slave inverters” in the system.

- Parallel connection wiring procedure

Step 1: Loosen the screws on the COM 1 terminal. Pinch the tabs on the sides of the COM 1 connector enclosure and pull it at the same time to disassemble it.

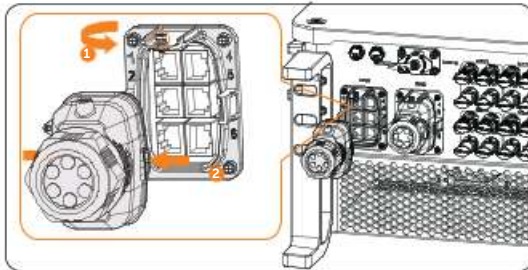

Figure 7-29 Removing the connector enclosure

Step 2: Anti-clockwise loosen the swivel nut and pull out the sealing plugs. Keep the sealing plugs still in the cable support sleeve if you choose not to connect the cable.

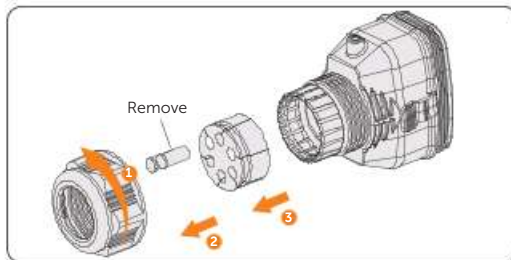

Figure 7-30 Disassembling the connector

Step 3: Thread the network cables.

- » Method 1: If your network cable has already been connected with RJ45 terminal (part E3), you can directly thread the cable through the swivel nut, cable support sleeve and connector enclosure in sequence.

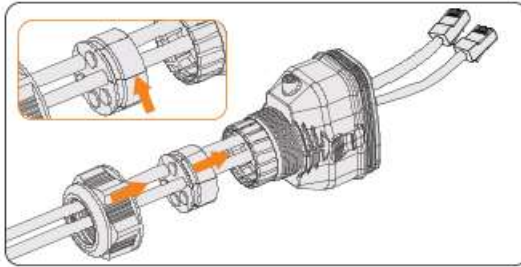

Figure 7-31 Threading the cables with RJ45 terminal

- » Method 2: If your network cable is not connected to an RJ45 terminal, you will need to assemble the cable before proceeding.

Thread the cables without RJ45 terminal through the swivel nut, cable support sleeve, and connector enclosure in sequence. Strip approx. 15 mm of the cable insulation.

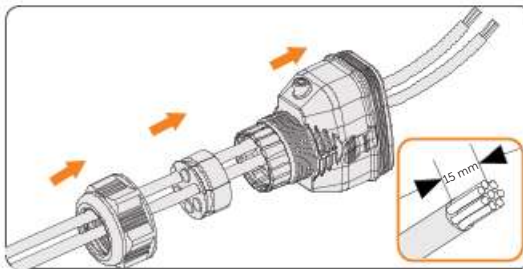

Figure 7-32 Threading the cables and stripping the insulation

Insert the stripped section into the RJ45 terminal. Crimp it tightly with a crimping tool for RJ45. Pay attention to pin order of RJ45 terminal.

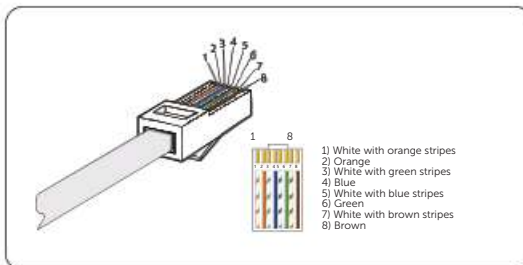

Figure 7-33 Crimping the communication cable

NOTICE!

- Use network cable tester to test the crimped cable before connecting to the inverter.

Step 4: Install the network cables with a crimped RJ45 terminal to Parallel-1 and Parallel -2 of cable clamp (part C3) according to the labeling.

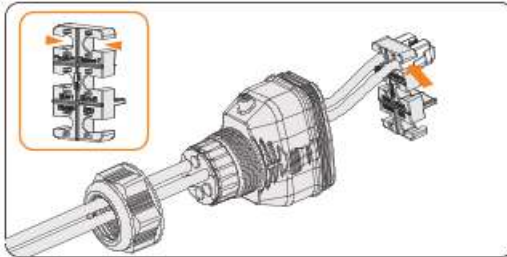

Figure 7-34 Installing the cable to the cable clamp

Step 5: Connect the assembled connector to COM 1 terminal. Ensure the cable clamp tongue is well inserted into the slot of terminal. You will hear an audible "Click" if it is connected securely. Lightly pull the cable for double check its connection.

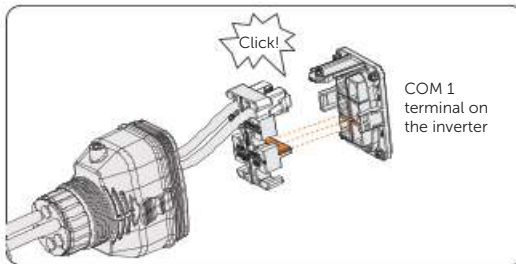

Figure 7-35 Inserting the connector to COM 1

- Step 6:** Secure the assembled connector on COM 1 terminal.
- Install the connector enclosure back into the COM 1 terminal.
 - Install the cable support sleeve into the enclosure.
 - Tighten M3 screw to secure it. (Torque: 0.6 ± 0.1 N·m)
 - Clockwise tighten the swivel nut to finish the COM 1 wiring connection.

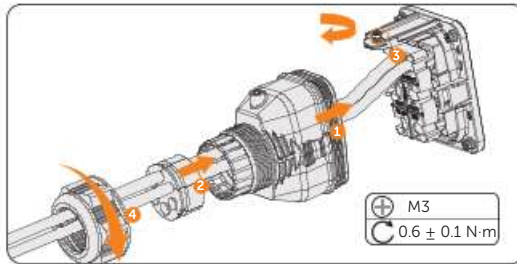

Figure 7-36 Securing the connector

BMS communication connection

Through BMS 1 and BMS 2 communication terminal, the inverter can be connected to two AELIO-B200 battery cabinet.

- BMS connection diagram

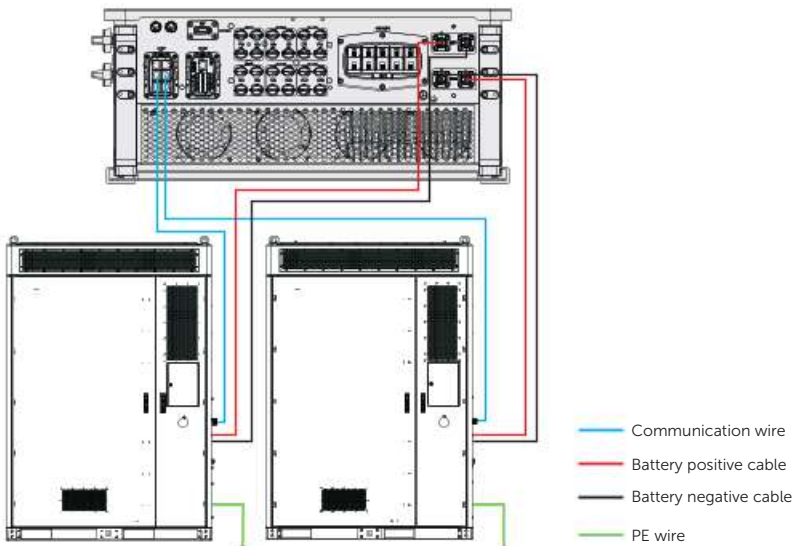

Figure 7-37 BMS connection diagram

- BMS wiring procedure

- Step 1:** Loosen the screws on the COM 1 terminal. Pinch the tabs on the sides of the COM1 connector enclosure and pull it at the same time to remove it.
- Step 2:** Anti-clockwise loosen the swivel nut and pull out the sealing plugs. Keep them still in the cable support sleeve if you choose not to connect the cable.
- Step 3:** Thread the cables through the swivel nut, cable support sleeve, and connector enclosure in sequence.
- Step 4:** Install the network cables to BMS-1 and BMS -2 of cable clamp according to the labeling.

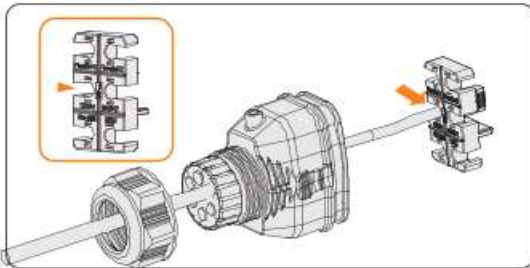

Figure 7-38 Installing RJ45 terminal to the cable clamp

- Step 5:** Connect the assembled connector to COM 1 terminal. Make sure the cable clamp tongue is well inserted into the slot of terminal. You will hear an audible "Click" if it is connected securely. Lightly pull the cable backward for double check its connection.
- Step 6:** Secure the assembled connector on COM 1 terminal.
- a. Install the connector enclosure back into the COM 1 terminal.
 - b. Install the cable support sleeve into the enclosure.
 - c. Tighten M3 screw to secure it. (Torque: 0.6 ± 0.1 N·m)
 - d. Clockwise tighten the swivel nut to finish the COM 1 wiring connection.

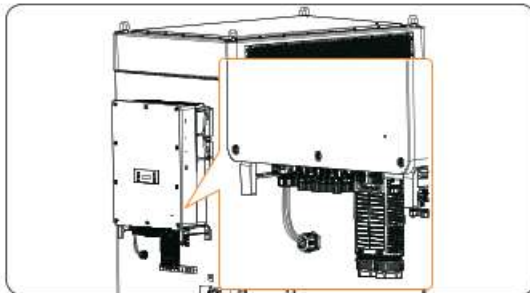

Figure 7-39 Well connected COM 1 cables

RS485 communication connection

NOTICE!

- Not all devices are compatible with 8 pin Network cables. In cases where 8 pin Network cables are not supported, it is required to re-crimp the RJ45 terminal according to the pin assignment.

- External device wiring procedure

Step 1: Loosen the screws on the COM 1 terminal. Pinch the tabs on the sides of the COM 1 connector enclosure and pull it at the same time to remove it.

Step 2: Anti-clockwise loosen the swivel nut and pull out the sealing plugs. Keep the sealing plugs still in the cable support sleeve if you choose not to connect the cable.

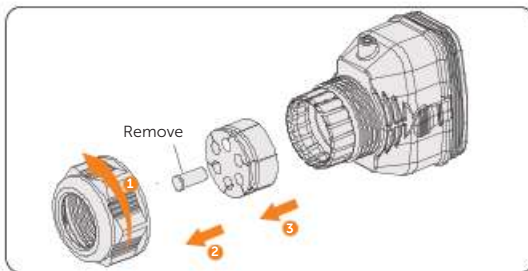

Figure 7-40 Disassembling the connector

Step 3: Thread the cables without RJ45 terminal through the swivel nut, cable support sleeve, and connector enclosure in sequence. Strip approx. 15 mm of the cable insulation.

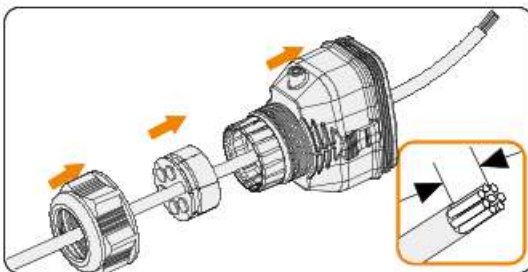

Figure 7-41 Threading the cables and stripping the insulation

Step 4: Insert the stripped section into the RJ45 terminal. Crimp it tightly with a crimping tool for RJ45. Pay attention to pin order of RJ45 terminal.

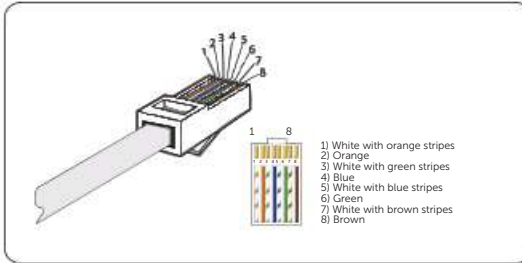

Figure 7-42 Crimping the communication cable

NOTICE!

- Use network cable tester to test the crimped cable before connecting to the inverter.

Step 5: Install the network cable of the crimped RJ45 terminal to RS485 of cable fixture according to the labeling.

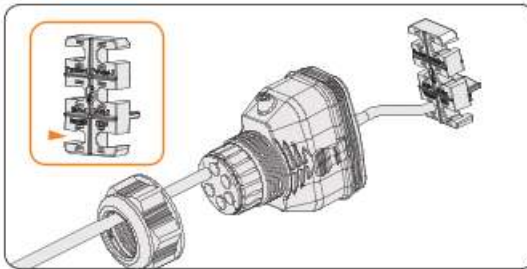

Figure 7-43 Installing RJ45 terminal to the cable fixture

Step 6: Connect the assembled connector to COM 1 terminal. Make sure the cable fixture tongue is well inserted into the slot of terminal. You will hear an audible "Click" if it is connected securely. Lightly pull the cable backward for double check its connection.

Step 7: Secure the assembled connector on COM 1 terminal.

- Install the connector enclosure back into the COM 1 terminal.
- Install the cable support sleeve into the enclosure.
- Tighten M3 screw to secure it. (Torque: 0.6 ± 0.1 N·m)
- Clockwise tighten the swivel nut to finish the COM 1 wiring connection.

DRM connection (applicable to AS/NZS 4777)

According to AS/NZS 4777, the inverter needs to support the function of demand response mode (DRM). With the use of an external control box, active or reactive power regulation can be realized in a timely and fast manner, and the inverter can be operated stably during the process of regulation.

DRM 0, DRM 1 and DRM 5 are available now.

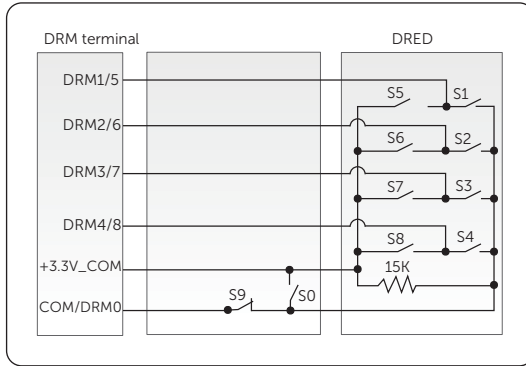

Figure 7-44 DRED connection diagram

Table 7-3 Descriptions of DRM

Mode	Pin	Requirement
DRM 0	Pin 6	<ul style="list-style-type: none"> When S0 is turned on, the inverters shut down. When S0 is turned off, the inverters restore grid connection.
DRM 1	Pin 1	<ul style="list-style-type: none"> When S1 is turned on, the inverters do not input active power.
DRM 5	Pin 1	<ul style="list-style-type: none"> When S5 is turned on, the inverters do not output active power.

- DRM connection wiring procedure

- Step 1:** Loosen the screws on the COM 1 terminal. Pinch the tabs on the sides of the COM 1 connector enclosure and pull it at the same time to remove it.
- Step 2:** Anti-clockwise loosen the swivel nut and pull out the sealing plugs. Keep them still in the cable support sleeve if you choose not to connect the cable.
- Step 3:** Thread the cable through the swivel nut, cable support sleeve, and connector enclosure in sequence.
- Step 4:** Install the network cable of the crimped RJ45 terminal to RS485 of cable fixture according to the labeling.

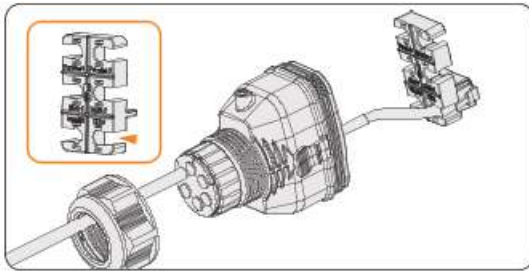

Figure 7-45 Installing RJ45 terminal to the cable fixture

- Step 5:** Connect the assembled connector to COM 1 terminal. Make sure the cable fixture tongue is well inserted into the slot of terminal. You will hear an audible "Click" if it is connected securely. Lightly pull the cable backward for double check its connection.
- Step 6:** Secure the assembled connector on COM 1 terminal.
- a. Install the connector enclosure back into the COM 1 terminal.
 - b. Install the cable support sleeve into the enclosure.
 - c. Tighten M3 screw to secure it. (Torque: 0.6 ± 0.1 N·m)
 - d. Clockwise tighten the swivel nut to finish the COM 1 wiring connection.

7.2.6 COM 2 Communication Connection

Pin assignment of COM 2 terminal

The COM 2 terminal is used for Meter/CT connection, ripple control and DIO function.

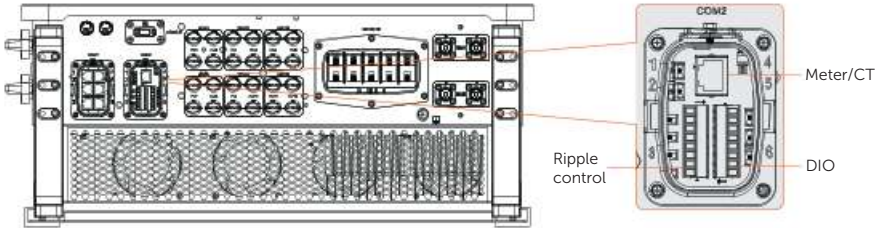

Table 7-4 Pin assignment of COM 2 terminal

Pin	Pin assignment
Meter/CT	
1	CT_R1_CON
2	CT_S1_CON
3	CT_T1_CON
4	METER_485A
5	METER_485B
6	CT_T2_CON
7	CT_S2_CON
8	CT_R2_CON
Ripple control	
1	RP_K4
2	GND_COM
3	RP_K3
4	GND_COM
5	RP_K2
6	GND_COM
7	RP_K1
8	GND_COM

Pin	Pin assignment
DIO port	
1	DO_1
2	DO_2
3	DI_1+
4	DI_1-
5	DI_2+
6	DI_2-
7	GND_COM
8	EPSBOX_RELAY_VCC

CT/Meter connection

The inverter should work with an electric meter or current transformer (CT for short) to monitor household electricity usage. The electricity meter or CT can transmit the relevant electricity data to the inverter or platform.

This section only introduces the wiring of the CT/Meter port of the inverter. For wiring procedures of the CT and meter side, see [“14.4 CT/Meter Connection Scenarios”](#).



- Compatible meters and CTs must be properly connected to the inverter, otherwise, the inverter will shut down and prompt a **Meter Fault** alarm.
- Meters and CTs that will be connected to the inverter must be authorized by SolaX. Unauthorized meters and CTs might be incompatible and cause damages to the inverter. SolaX will not be responsible for the impact caused by the use of other appliances.

Table 7-5 CT/Meter pin definition

	Pin	Pin assignment
For CT connection	1	CT_R1_CON
	2	CT_S1_CON
	3	CT_T1_CON
For Meter connection	4	METER_485A
	5	METER_485B

For CT connection	6	CT_T2_CON
	7	CT_S2_CON
	8	CT_R2_CON

- CT/Meter wiring procedure

Step 1: Loosen the screws on the COM 2 terminal. Pinch the tabs on the sides of the COM 2 connector enclosure and pull it at the same time to remove it.

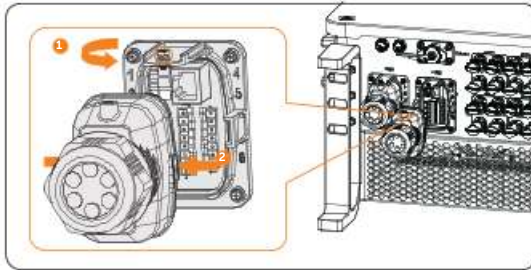

Figure 7-46 Disassembling the COM 2 terminal

Step 2: Loosen the swivel nut and pull out the sealing plugs. Keep them still in the cable support sleeve if you choose not to connect the cable.

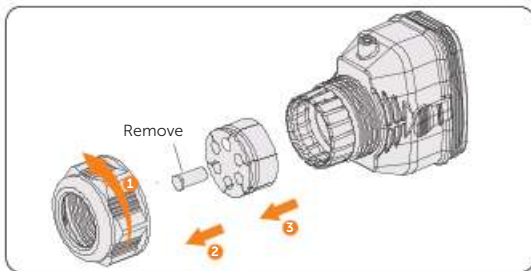

Figure 7-47 Disassembling the connector

Step 3: Directly thread the cable through the swivel nut, cable support sleeve and connector enclosure in sequence.

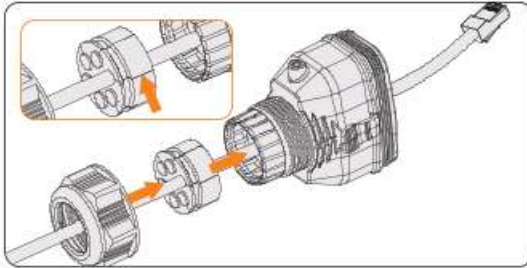

Figure 7-48 Threading the cable with RJ45 terminal

NOTICE!

- Use network cable tester to test the crimped cable before connection.

Step 4: Connect the assembled communication cable into the COM 2 terminal. Secure the assembled connector on COM 2 terminal.

- » Install the connector enclosure back into the COM 2 terminal.
- » Install the cable support sleeve into the enclosure.
- » Tighten M3 screw to secure it. (Torque: 0.6 ± 0.1 N·m)
- » Clockwise tighten the swivel nut to finish the COM 2 wiring connection.

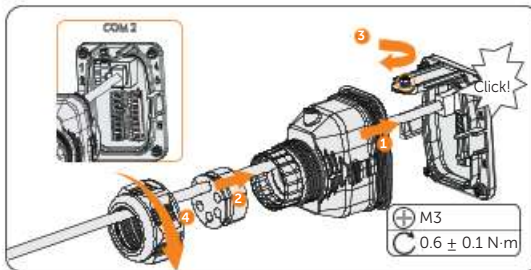

Figure 7-49 Connecting to COM 2

Ripple control communication connection

Ripple Control is a common form of grid management. Its communication is based on superimposing a very high frequency signal onto the 50 / 60 Hz mains power. The inverter supports to connect a digital signal source (e.g. ripple control receiver) to the digital input.

- Requirements for Ripple control
 - » The signal source must be technically suitable for connection to the digital inputs. (see technical data)
 - » The connected digital signal source has a safe separation to the grid potential.
- Connection diagram for ripple control

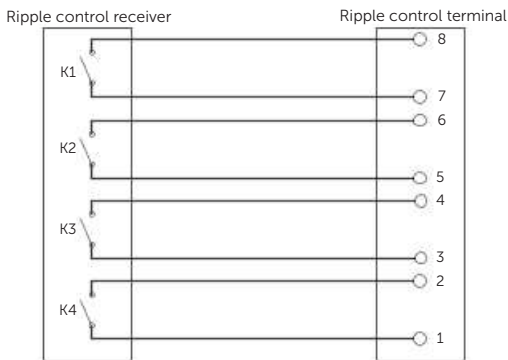

Figure 7-50 Connection diagram for ripple control

- Ripple control wiring procedure
- Step 1:** Loosen the screws on the COM 2 terminal. Pinch the tabs on the sides of the COM 2 connector enclosure and pull it at the same time to remove it.

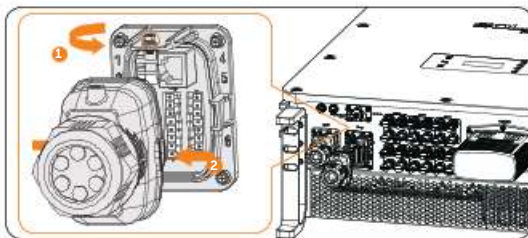

Figure 7-51 Disassembling the COM 2 terminal

Step 2: Loosen the swivel nut and pull out the sealing plugs. Keep them still in the cable support sleeve if you choose not to connect the cable.

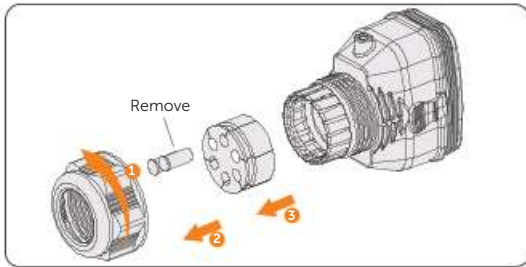

Figure 7-52 Disassembling the connector

Step 3: Prepare two four-core signal cables. Thread the cables through the swivel nut, cable support sleeve, and connector enclosure in sequence.

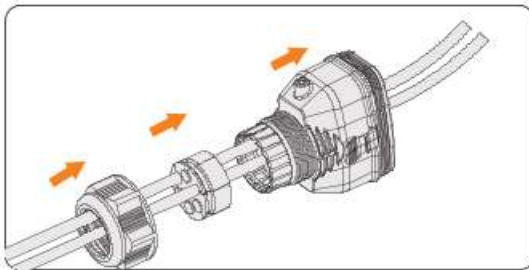

Figure 7-53 Threading the cables

Step 4: Strip approx. 6 mm of the cable insulation. Insert the conductors into the 8-pin terminal block (part F3) and tighten the terminal block screws. (torque: 0.2 ± 0.1 N·m) Ensure that the conductors are firmly seated in the terminal.

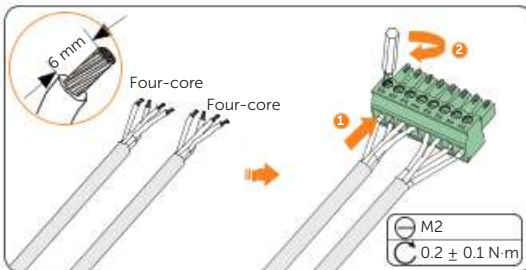

Figure 7-54 Connecting to 8-pin terminal block

Step 5: Connect the assembled communication cable into the COM 2 terminal. Lightly pull the cable backward to confirm tight insertion and then install the connector back.

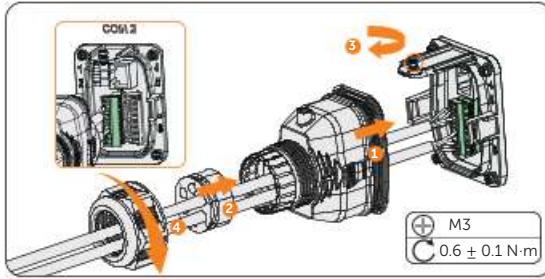

Figure 7-55 Connecting to the inverter

DIO communication connection

DIO terminal is designed to support generator and system switch connection through dry contact.

To enhance safety and reduce the risk of injury, you can install the system switch in a readily accessible location through dry contact connection. In the event of an emergency, the system switch can be easily reached and pressed to promptly switch off the entire system, ensuring a swift response and preventing further harm.

For generator, please refer to corresponding user manual for specific application.

Table 7-6 DIO pin definition

	Pin	Pin assignment
For generator dry contact output	1	DO_1
	2	DO_2
For system switch dry contact input	3	DI_1+
	4	DI_1-
Reserved	5	DI_2+
	6	DI_2-
Reserved	7	GND_COM
For power supply	8	EPSBOX_RELAY_VCC

NOTICE!

- If there is strong interference in the surroundings, it is recommended to use shielding cables and ground the shielding layer of the cables through Pin 7.

- System switch connection diagram

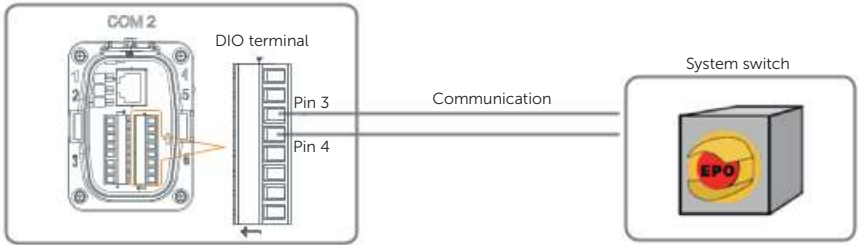

Figure 7-56 System switch connection diagram

Choose a self-locking switch for the system. When system switch is pressed, **OFF MODE (DIO SW)** will be displayed on the LCD screen and the system will be powered off. To release the switch, press it again.

- DIO wiring procedure

- Step 1:** Loosen the screws on the COM 2 terminal. Pinch the tabs on the sides of the COM 2 connector enclosure and pull it at the same time to remove it.
- Step 2:** Loosen the swivel nut and pull out the sealing plugs. Keep them still in the cable support sleeve if you choose not to connect the cable.
- Step 3:** Prepare two four-core signal cable. Thread the cables through the swivel nut, cable support sleeve, and connector enclosure in sequence.
- Step 4:** Strip approx. 6 mm of the cable insulation. Insert the conductors into the 8-pin terminal block and tighten the terminal block screws. (torque: 0.2 ± 0.1 N·m) Ensure that the conductors are firmly seated in the terminal.

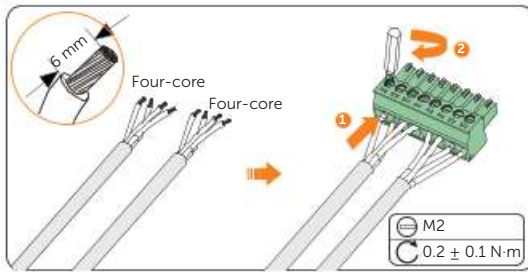

Figure 7-57 Connecting to 8-pin terminal block

Step 5: Connect the assembled communication cable into the COM 2 terminal. Lightly pull the cable backward to confirm tight insertion and then install the connector back.

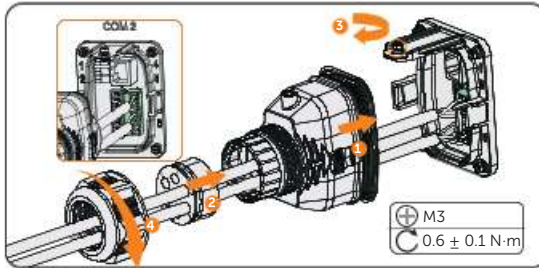

Figure 7-58 Connecting to the inverter

7.3 EPS Connection

Wiring area "Area b" must be connected EPS wires. Please strictly follow the steps below.

NOTICE!

- Take out the underground electrical wiring which is buried beneath the ground.
- Regarding the terminal requirements, please refer to "14.1 Requirements for OT/DT Terminal".

Step 1: Use keys to open the front doors.

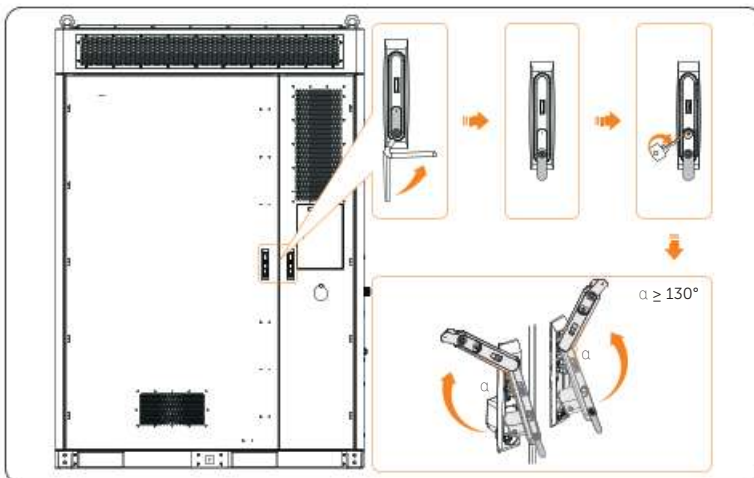

Figure 7-59 Opening front doors

NOTICE!

- Please keep the keys properly.

Step 2: Strip the four-core cable about 250 mm to 270 mm.
Strip the cable jacket (for L1/L2/L3/N) about 20 mm.

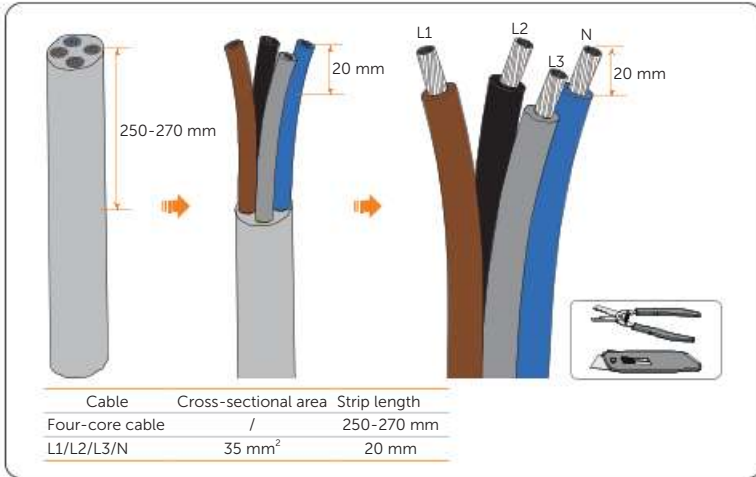

Figure 7-60 Stripping cable jacket

NOTICE!

- It's important to give the power cable a health check before stripping it.
- It's necessary to use controlled motion to strip the insulation down the wire, to prevent damage to the wires.
- Make sure that the insulation layer has been stripped to a sufficient length so that the center conductor is fully exposed without any damage or nicks. In addition, make sure that no extra insulation remains beyond the connector once it's crimped on.

- Step 3:** Cut the heat-shrink tubing ($\text{Ø}15\text{-}20\text{ mm}$) to about 50 mm to 60 mm length for L1/L2/L3/N wires; Carefully slide it onto the end of the cable, and then carefully slip the wires all the way into the copper terminals (part M1).

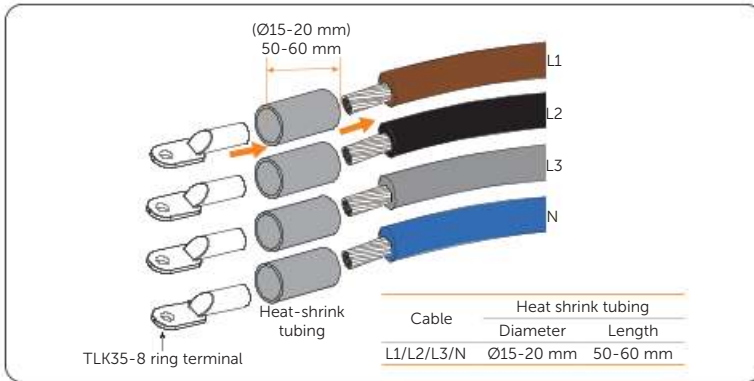

Figure 7-61 Slipping wires

- Step 4:** Crimp the terminal using hydraulic wire crimper. Since the procedure for installing a terminal is same, take the L1 wire, for instance.

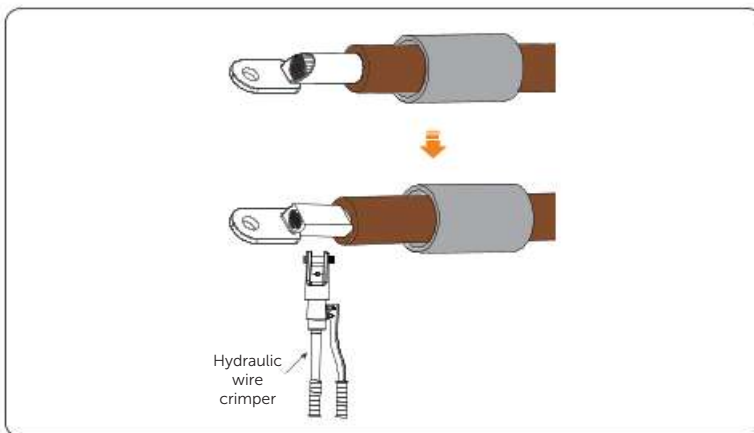

Figure 7-62 Crimping

NOTICE!

- Do not damage the conductor insulation while crimping.
- Do not place the conductor insulation into the terminal.

Step 5: Heat the heat-shrink tubing after it wraps the end of terminal.

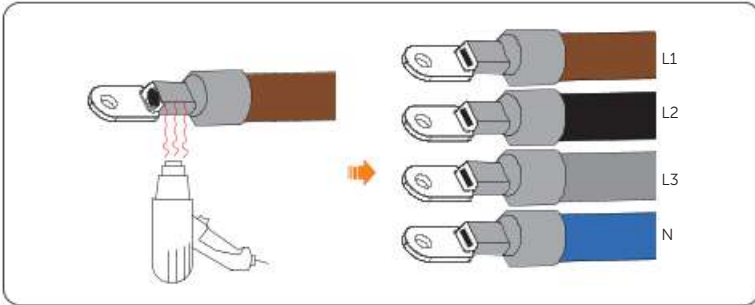

Figure 7-63 Heating

NOTICE!

- Move the heat gun back and forth slowly to distribute the heat evenly across the surface of heat shrink tubing.

Step 6: Unscrew M5 butterfly nuts to remove the cable hole cover, and unscrew M6 screws to open the cable clamp.

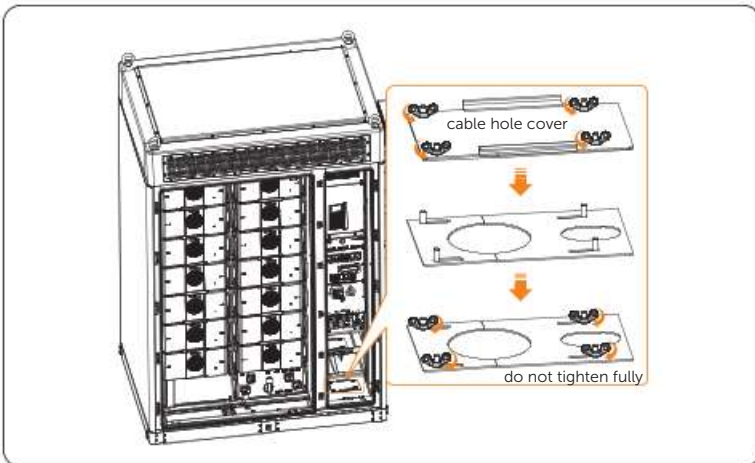

Figure 7-64 Unscrewing M5 butterfly nuts

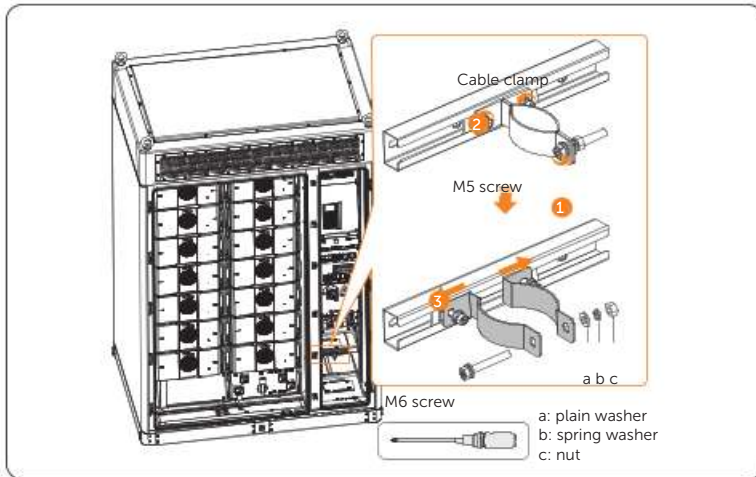

Figure 7-65 Unscrewing M6 screw

NOTICE!

- Please keep the screw, washers and nut properly.

Step 7: Unscrew M4 screws to remove the cover. There are four bars in the connection area. Each bar has two holes, and it is recommended to connect wires in the green area.

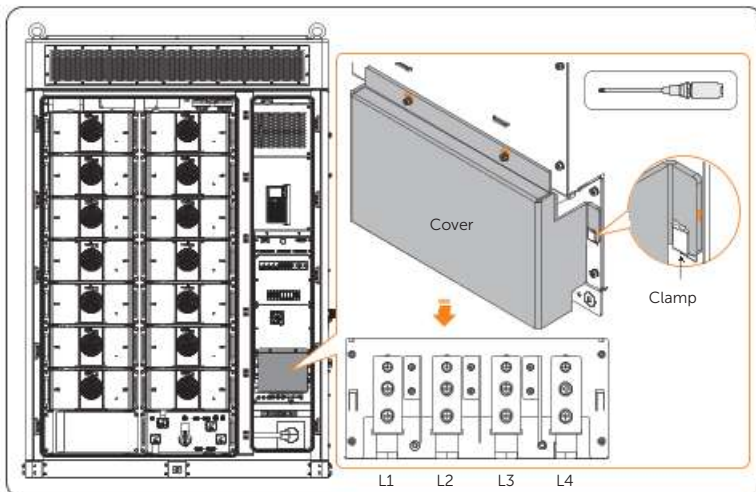

Figure 7-66 Removing cover

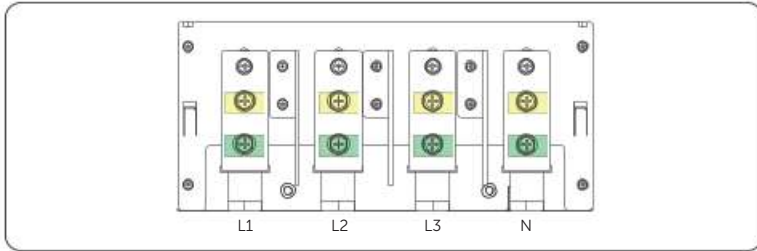

Figure 7-67 Connection area

NOTICE!

- Please keep the M4 screws and cover properly.

Step 8: There are two options (a and b) for pulling through the EPS wires. Therefore, thread it through option a or b from the outside to the inside.

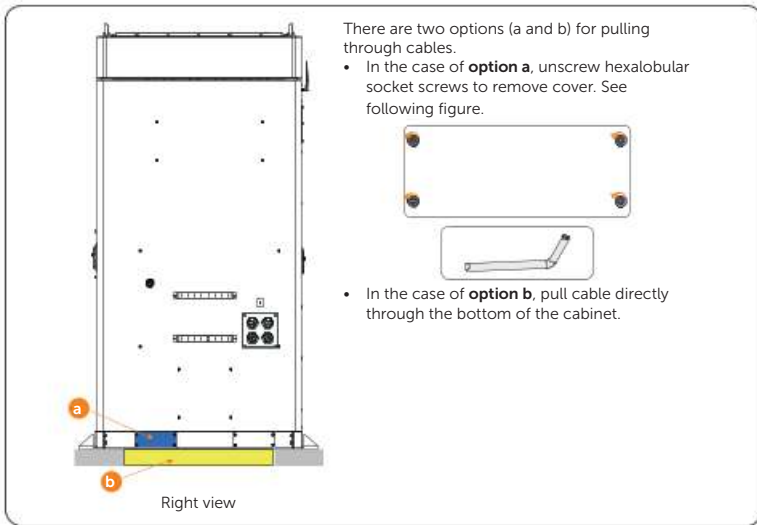

Figure 7-68 Threading EPS wires

- Step 9:** Run the EPS wires through the clamp, and insert M8 screws to secure and connect the assembled L1/L2/L3/N wires to the wire interface, and then tighten them (torque: 12 ± 1 N·m).

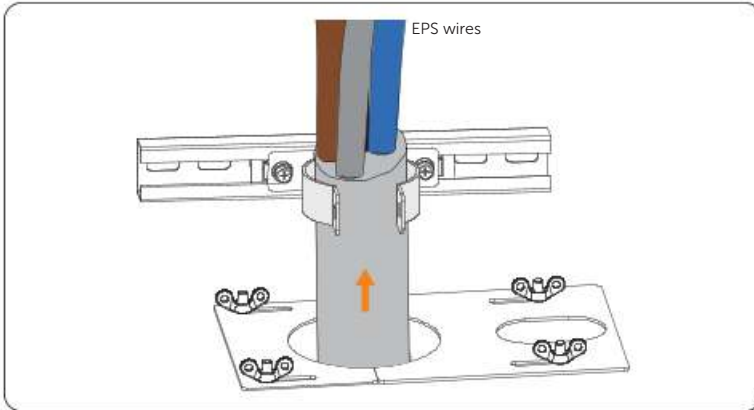

Figure 7-69 Threading grid wires

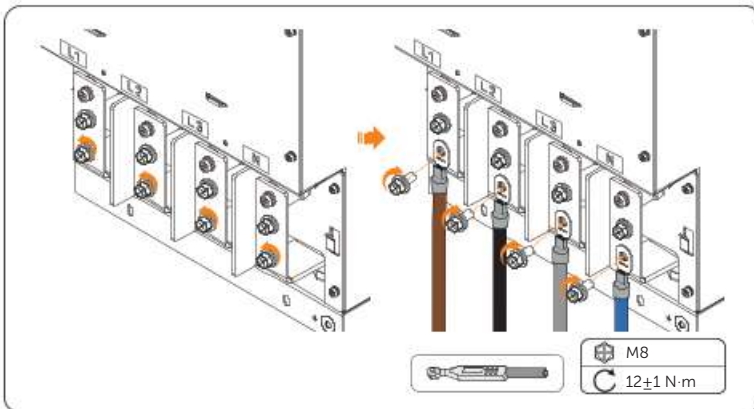

Figure 7-70 Connecting L1, L2, L3 and N wires

Step 10: Insert and tighten M5 and M6 screws (torque for M5: 3 ± 0.3 N·m; torque for M6: 5 ± 0.5 N·m), and then fully tighten M5 butterfly nuts.

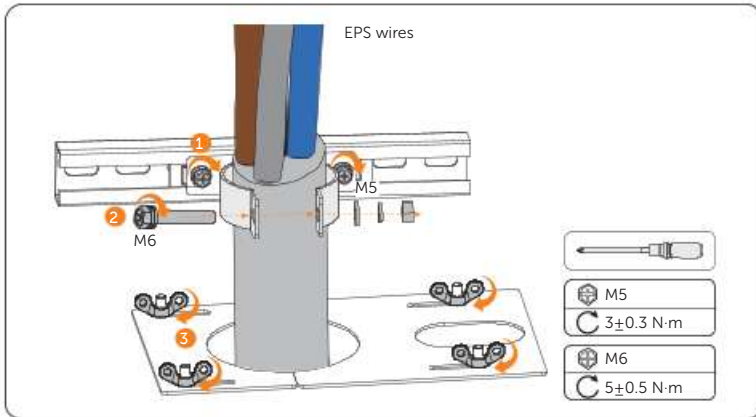

Figure 7-71 Tightening screws

NOTICE!

- The small hole is used to thread communication cable, if the number of cabinets is over 2.

Step 11: Attach the cover, and insert and tighten the M4 screws (torque: 1.2 ± 0.1 N·m).

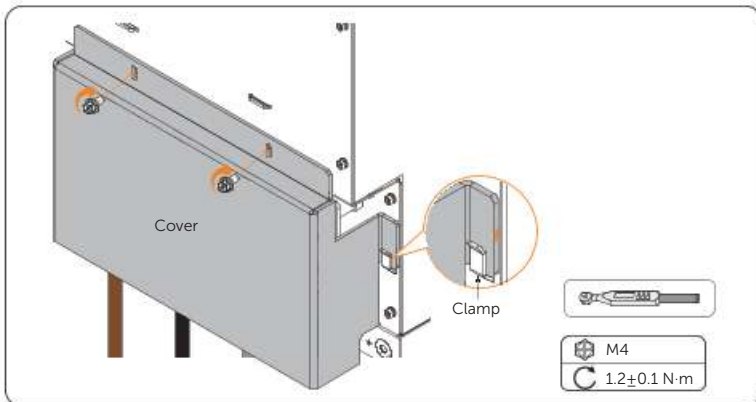

Figure 7-72 Securing cover

7.4 Grid Connection

Wiring area "Area c" must be connected GRID wires. Please strictly follow the steps below.

NOTICE!

- Take out the underground electrical wiring which is buried beneath the ground.
- Regarding the terminal requirements, please refer to "14.1 Requirements for OT/DT Terminal".

Step 1: Use keys to open the rear door.

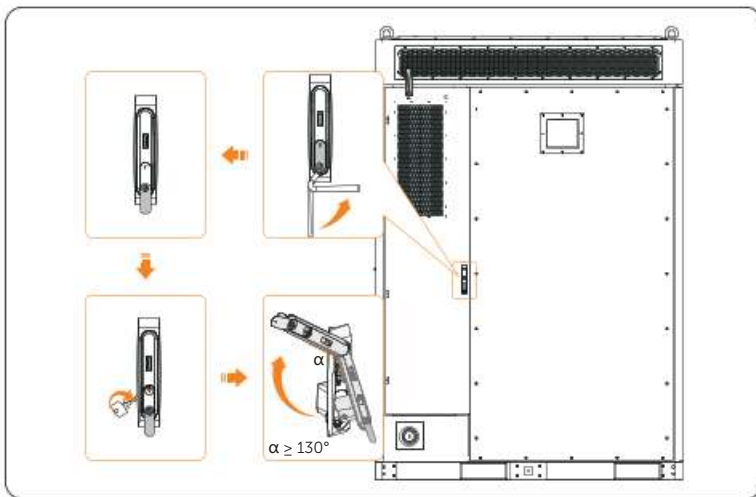

Figure 7-73 Opening rear door

- Step 2:** Strip the five-core cable about 160 mm to 180 mm;
Strip the cable jacket (for L1/L2/L3/N) about 20 mm;
Strip the PE cable jacket about 15 mm to 20 mm.

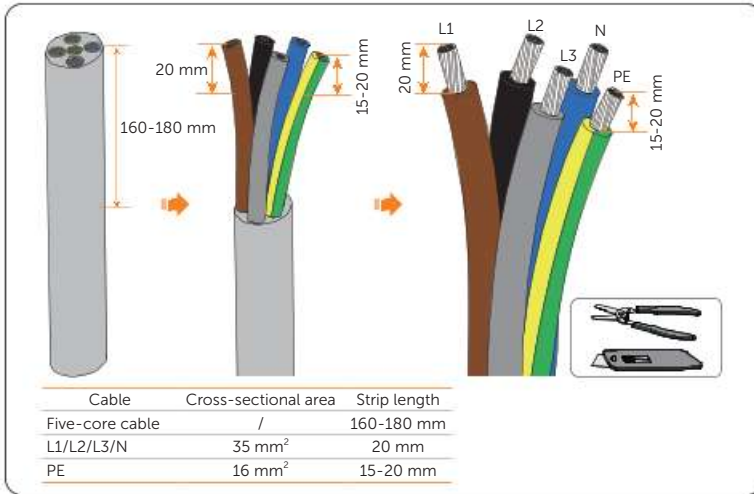

Figure 7-74 Stripping cable jacket

NOTICE!

- It's important to give the power cable a health check before stripping it.
- It's necessary to use controlled motion to strip the insulation down the wire, to prevent damage to the wires.
- Make sure that the insulation layer has been stripped to a sufficient length so that the center conductor is fully exposed without any damage or nicks. In addition, make sure that no extra insulation remains beyond the connector once it's crimped on.

- Step 3:** Cut the heat-shrink tubing (Ø17~25 mm) to about 50 to 60 mm length for L1/L2/L3/N wires;
Cut the heat-shrink tubing (Ø10-15 mm) to about 30 to 40 mm length for PE wire;
Carefully slide it onto the end of the cable, and then carefully slip the wires all the way into the copper terminals (part M1).

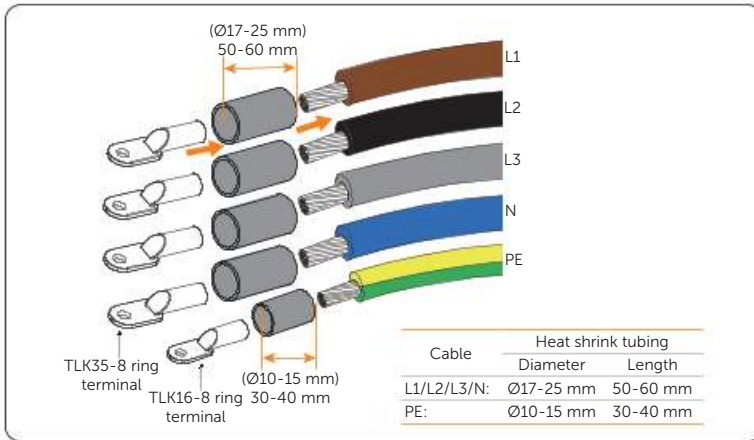

Figure 7-75 Cutting heat-shrink tubing

Step 4: Crimp the terminal using hydraulic wire crimper. Since the procedure for installing a terminal is same, take the L1 wire, for instance.

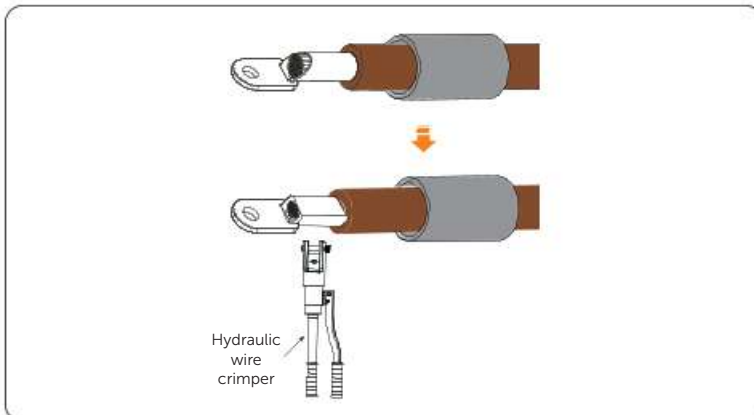

Figure 7-76 Crimping

NOTICE!

- Do not damage the conductor insulation while crimping.
- Do not place the conductor insulation into the terminal.

Step 5: Heat the heat-shrink tubing after it wraps the end of terminal.

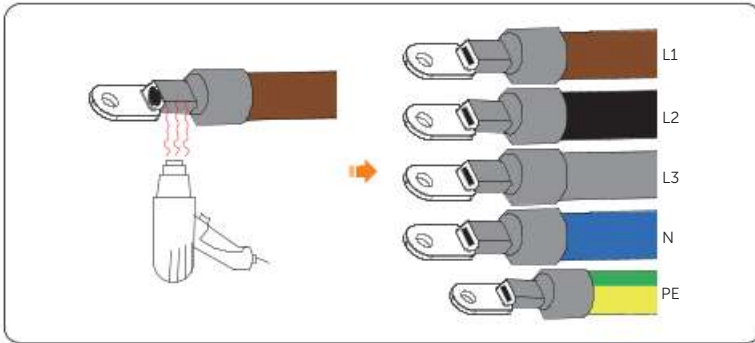

Figure 7-77 Heating heat-shrink tubing

NOTICE!

- Move the heat gun back and forth slowly to distribute the heat evenly across the surface of heat shrink tubing.

Step 6: Unscrew M5 butterfly nuts to remove the cable hole cover, and unscrew M6 screws to open the cable clamp.

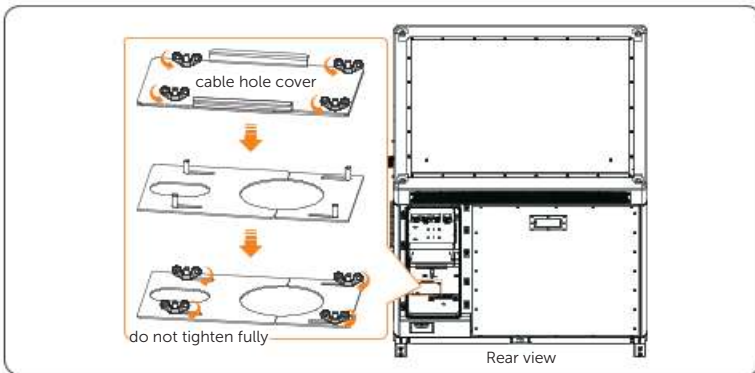

Figure 7-78 Unscrewing M5 butterfly nuts

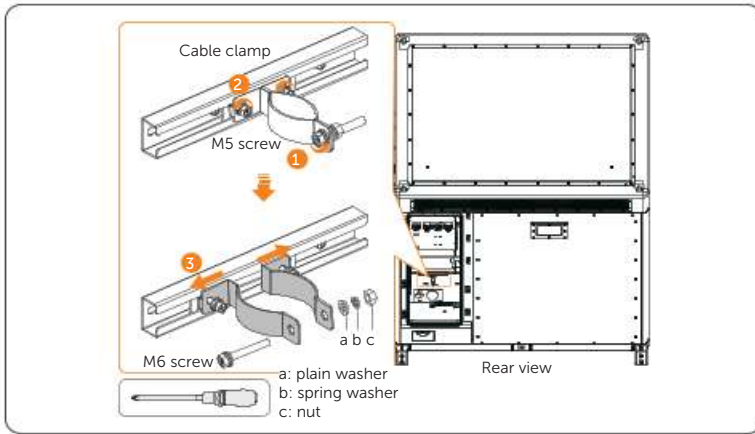

Figure 7-79 Unscrewing M6 screw

NOTICE!

- Please keep the screw, washers and nut properly.

Step 7: Unscrew M5 screws to remove the cover. There are four bars in the connection area. Each bar has two holes, and it is recommended to connect wires in the green area.

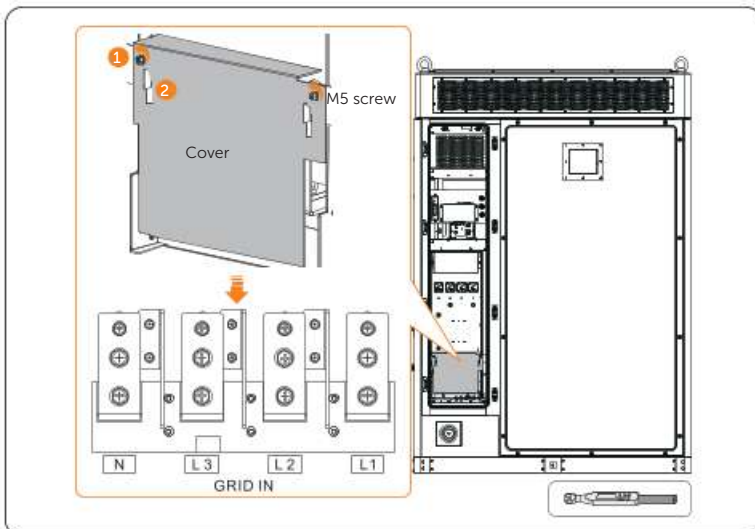

Figure 7-80 Removing cover

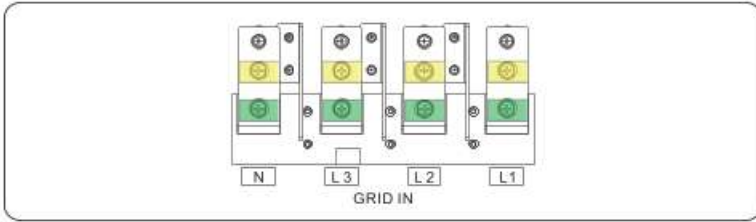

Figure 7-81 Connection area

NOTICE!

- Please keep the M5 screws and cover properly.

Step 8: There are two options (a and b) for pulling through the grid wires. Therefore, thread it through option a or b from the outside to the inside.

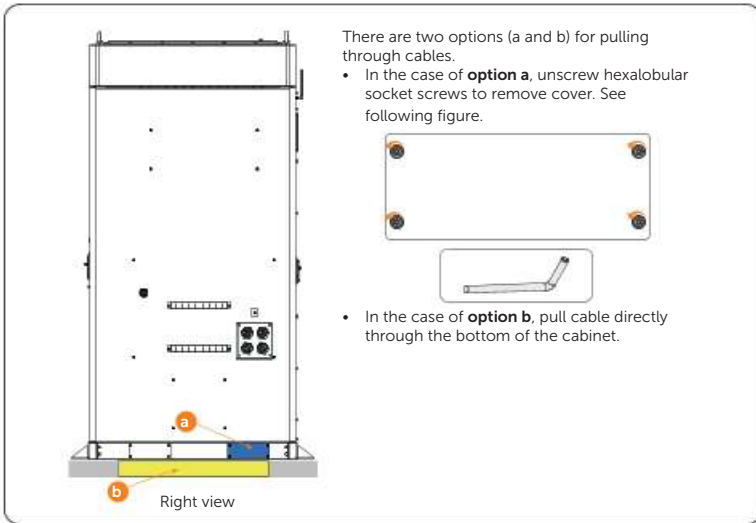

Figure 7-82 Threading grid wires

Step 9: Run the grid wires through the clamp, and insert M8 screws to secure and connect the assembled L1/L2/L3/N wires to the wire interface, and then tighten them (torque: 12 ± 1 N·m).

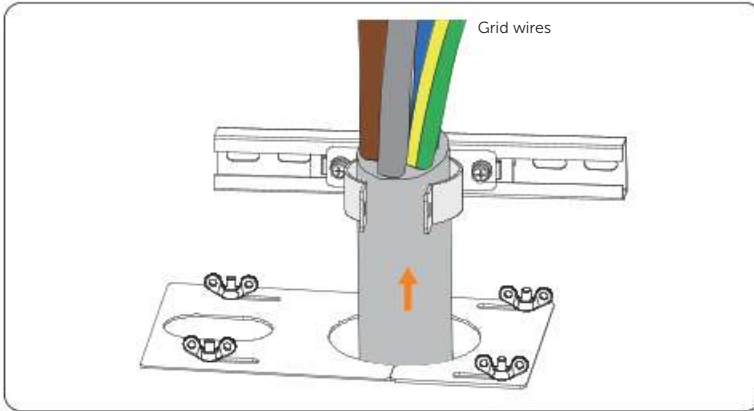

Figure 7-83 Threading grid wires

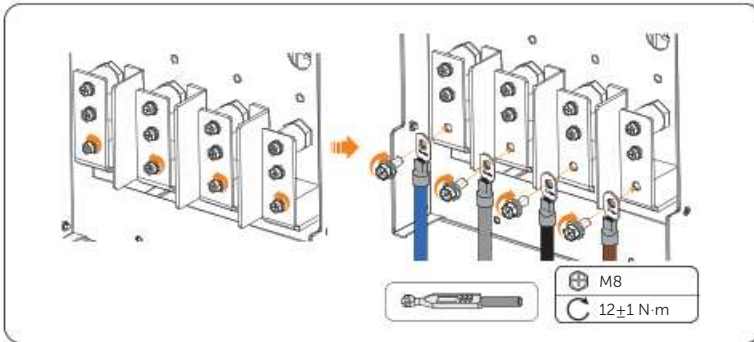

Figure 7-84 Connecting L1, L2, L3 and N wires

Step 10: Insert and tighten M5 and M6 screws (torque for M5: 3 ± 0.3 N·m; torque for M6: 5 ± 0.5 N·m), and then fully tighten M5 butterfly nuts.

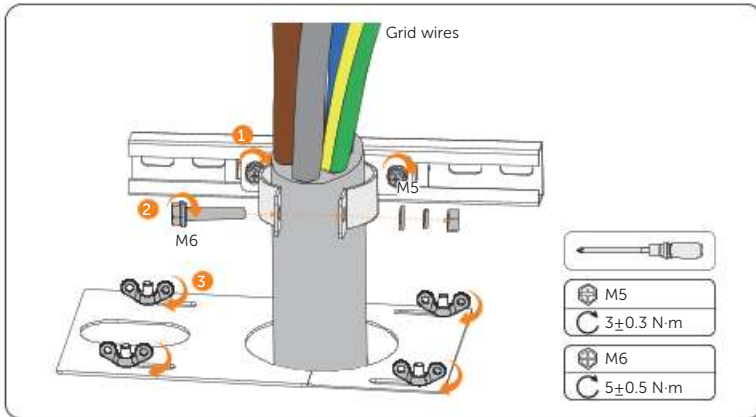

Figure 7-85 Tightening screws

NOTICE!

- The small hole is used to thread communication cable, if the number of cabinets is over 2.

Step 11: There are two M8 screws, and either one of them can be connected to the PE wire. Hence, unscrew a M8 screw using a torque wrench, connect the assembled PE wire to the copper bar, and then tighten it (torque: 12 ± 1 N·m).

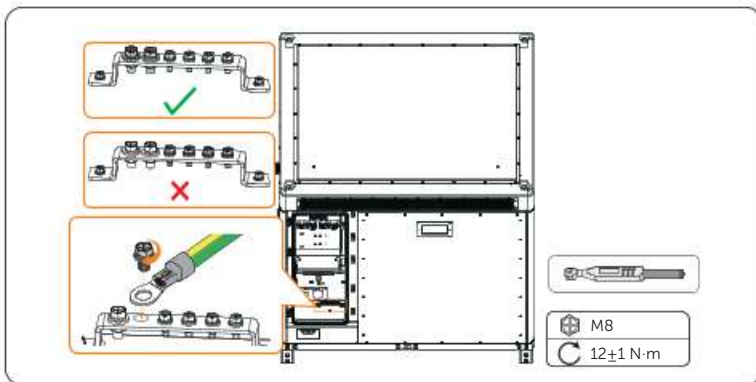

Figure 7-86 Connecting PE wire

Step 12: Reattach the cover over the hooks to the cabinet, and then correctly insert and tighten M5 screws (torque: 3.0 ± 0.3 N·m).

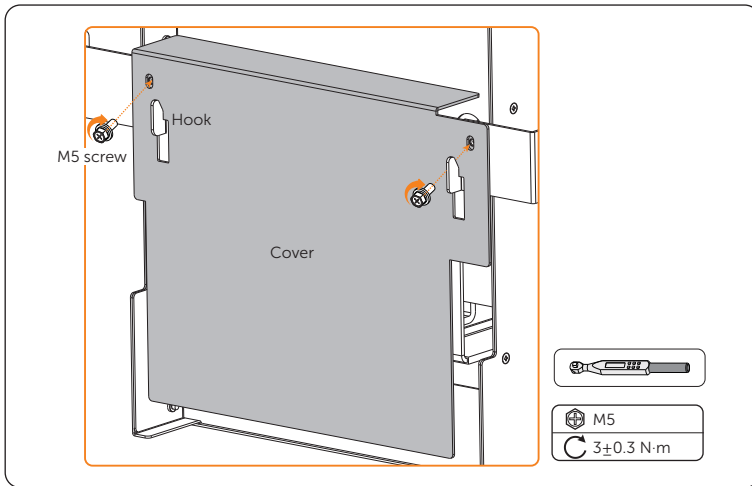

Figure 7-87 Reattaching cover

NOTICE!

- Must clean the materials, such as metal parts, screws, etc., in the cabinet after finishing wiring.

7.5 Fireproof Mud

After finishing wiring, the cable threading holes must be laid with fireproof mud.

Step 1: Lay the fireproof mud (part G) to plug the cable threading holes on both front and rear sides of the cabinet.

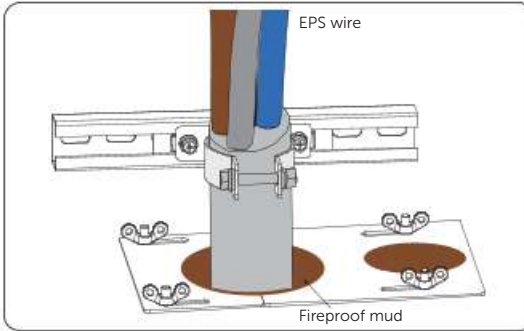

Figure 7-88 Plugging the cable threading hole on the front side

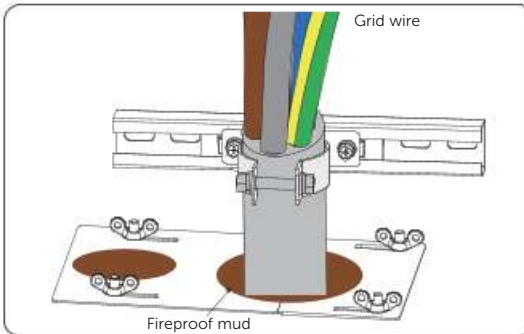

Figure 7-89 Plugging the cable threading hole on the rear side

NOTICE!

Notice for fireproofing mud:

- Take out the fireproof mud delivered with the cabinet and knead it into a ball shape. In the case of the low temperature, place it into warm water, of which the temperature range is between 40°C and 70 °C, with its package until it is soft.
- Clean the area around the cable threading hole before sealing it.
- The fireproof mud should be evenly spread, embedded, or filled in the cable threading hole. If such a hole is too large, a fireproofing board can be placed to enhance fire protection before using the mud.
- The fireproof mud needs to be cured after sealing the cable threading hole. Prevent water from entering and colliding during curing.

7.6 Installation Procedure for Cable Cover

NOTICE!

- Do not install the cable cover until the all the cables are wired.

Step 1: Unscrew M6 hexalobular screws, with a total of 8 screws (a1, a2, a3 and a4 for large cable cover, and b1, b2,b3 and b4 for small cable cover).

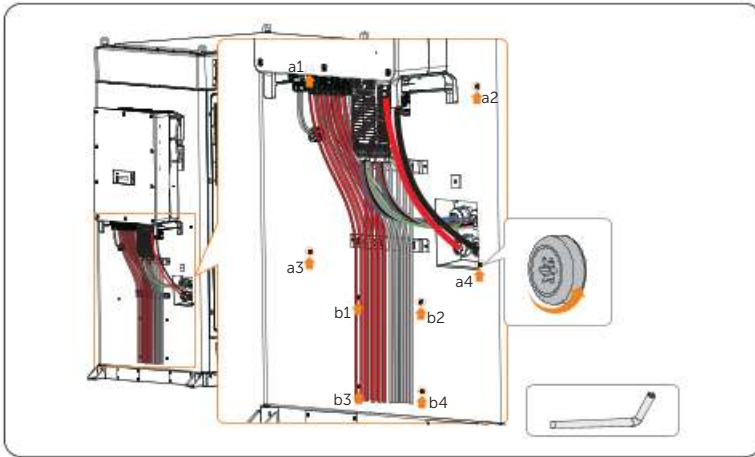

Figure 7-90 Unscrew M6 screws

NOTICE!

- Keep these M6 screws properly.

Step 2: Attach the large cable cover (part B1) to the cabinet, and insert and tighten the M6 hexalobular screws by using a hexalobular key.

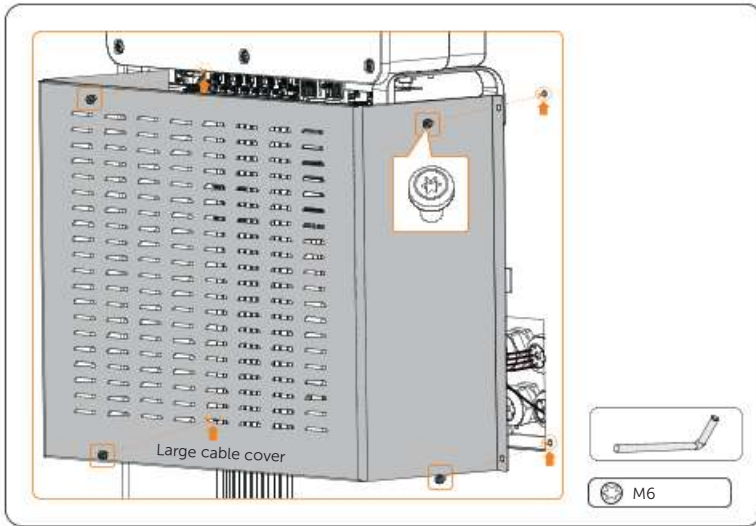

Figure 7-91 Attaching large cable cover

Step 3: Attach the small cable cover (part C1) to the cabinet, and insert and tighten the M6 hexalobular screws by using a hexalobular key.

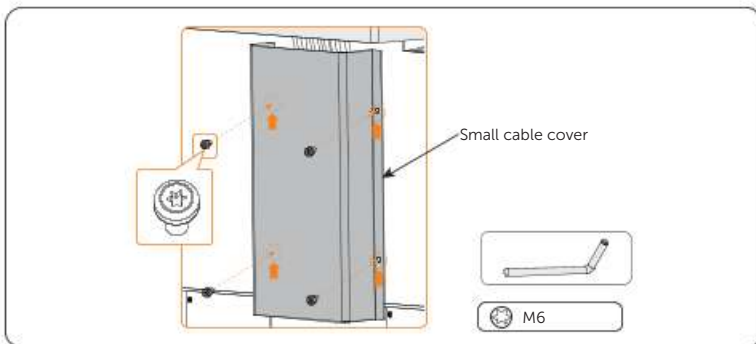

Figure 7-92 Attaching small cable cover

NOTICE!

- Must clean the materials, such as metal parts, screws, etc., in the cabinet after finishing wiring.
- It is recommended to seal off the gap between foundations after finishing wiring.

8 System Commissioning

8.1 Checking before Power-on

Ensure that all the cables connecting to the EPS and distribution box (grid side) are wired and securely fastened. For details, please refer to the following Table 8-1.

Table 8-1 Checklist

No.	Item	Description
1	Device appearance	<ul style="list-style-type: none">• Check the device is in good condition, with a clean, non-peeling paint, and rust-free surface.• Ensure that the labels on the device are clear and easy to read. If it is damaged, the label shall be replaced at once.
2	Installation	<ul style="list-style-type: none">• The battery cabinet, inverter and other device (if any) are installed correctly and securely.• All the screws are tightened.
3	Cable appearance	<ul style="list-style-type: none">• Check that the cable jacket is in good condition.• Check that the protective pipes are in good condition.
4	Cable connection	<ul style="list-style-type: none">• Check that the cable connection position is consistent with the design principles.• Ensure that the procedure for crimping terminals strictly observe the requirements, and the terminals are securely fastened.• Check that the labels on the both sides of cables are clear, and the direction of both labels is the same.• Check that all DC, AC cables, ground cable, communication cables and meter/CT of the inverter are connected correctly and securely• Check that the external AC and DC connectors are connected; The connectors on the Grid and EPS terminal are connected correctly and securely.• Check the unused terminals and ports of the inverter are locked by waterproof caps.• Check that all photovoltaic panels are connected correctly and securely.

No.	Item	Description
5	Wiring	<ul style="list-style-type: none"> • Ensure that the wiring procedure is consistent with the principle of separation of strong and weak electricity. • Ensure that the cables are neatly places. • Leave a little extra length for adjustments. • Keep cables tidy in the cabinet. • Check if the grid connection voltage meets: $L1+N=220/230$ V, $L2+N=220/230$ V, $L3+N=220/230$ V, $L1+L2=380/400$ V, $L2+L3=380/400$ V, $L1+L3=380/400$ V.
6	Copper bars in the battery pack	<ul style="list-style-type: none"> • Check to make sure the copper bars are not deformed.
7	Button/Switch	<ul style="list-style-type: none"> • Check the distribution box's switch is "OFF". • Check the battery packs' switches are "OFF". • All the DC breakers and AC breakers are "OFF"

8.2 Power ON

NOTICE!

- Please check that the emergency stop button remains in the closed position before powering on.

Regarding the detailed location of the modules in the cabinet, see following figure.

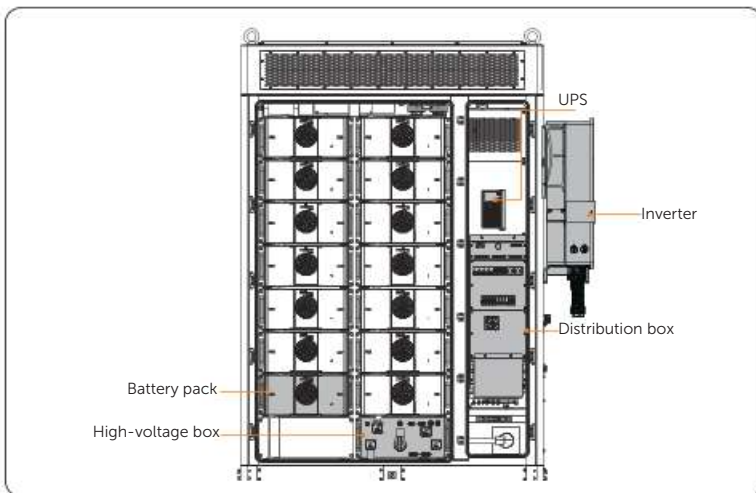

Figure 8-1 Location of modules

Step 1: Start the distribution box.

- » Rotate the switch on the distribution box 90° clockwise to "ON";
- » Flip up the "SPD MCB" breaker;
- » Flip up the "HVAC MCB" breaker;
- » Flip up the "EPS" breaker;
- » Flip up the "APS" breaker;
- » Flip up the "UPS" breaker.

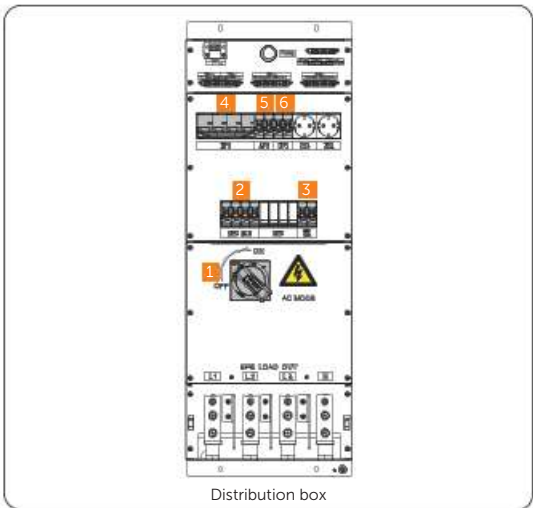

Figure 8-1 Starting sequence of distribution box

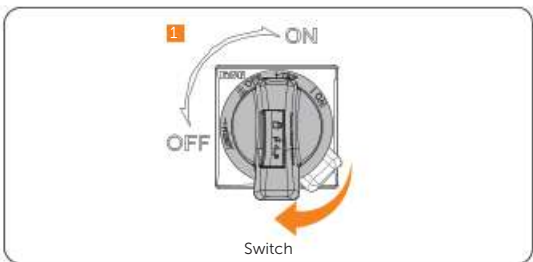

Figure 8-2 Rotating switch

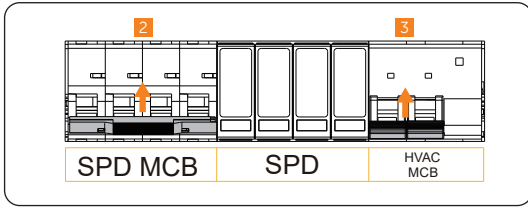

Figure 8-3 Flipping up breakers

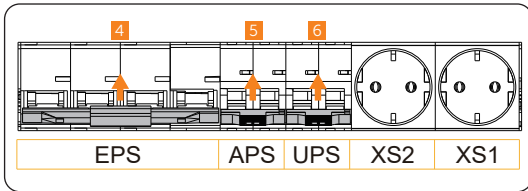

Figure 8-4 Flipping up breakers

Step 2: The startup sound on boot will be heard when holding and pressing the "Power on/off" button to start the UPS.

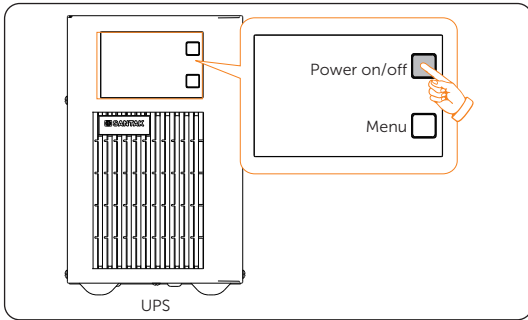

Figure 8-5 Holding and pressing button

Step 3: Rotate the disconnecter of the high-voltage box to "ON", and then gently press the power button. At the point, the LED light will come on green.

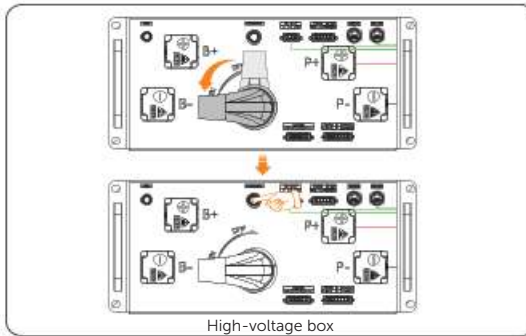

Figure 8-6 Starting the high-voltage box

Step 4: Close the door after the device has been started.

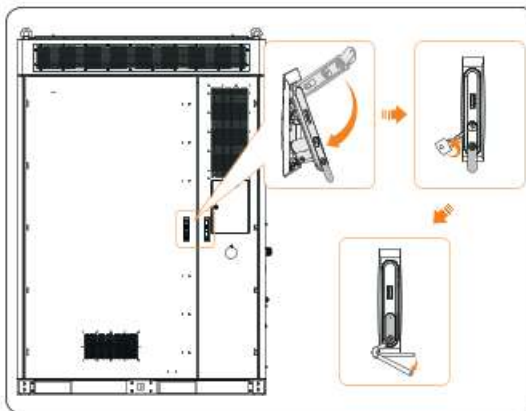

Figure 8-7 Closing the door

NOTICE!

- Please properly keep the key.

Step 5: Start the inverter.

- Turn on the AC breakers between the inverter and the grid & EPS load and check whether the LCD screen lights on.
 - » If the LCD screen is not on, turn off the AC breakers and check whether the Grid cable is connected correctly and securely.
- Switch on the inverter DC switch and check the LCD screen, check the PV voltage.
 - » If the PV voltage is 0, turn off the DC switch, pull out the PV connectors

and then measure the voltage of the positive and negative PV port (in MPPT voltage range 160-950 V) or check whether the positive and negative poles of PV cables are reversed.

- c. Press and turn on the inverter system button.

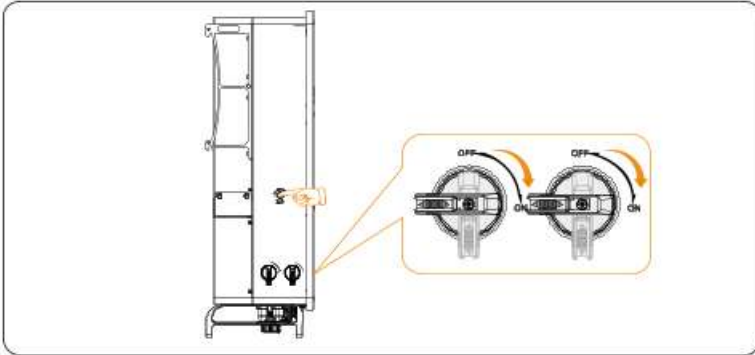

Figure 8-8 Starting the inverter

- d. Set **System ON/OFF** as ON status on the inverter screen, and the LCD displays waiting status.
- e. When the photovoltaic panels generate enough power or the battery supplies power, the inverter will start automatically. The inverter will go Waiting, Checking and Normal status in sequence.
- f. Check whether the meter/CT is correctly connected.
 - » If CT is connected, please perform the Meter/CT Check to check the correct connection through the setting path: **Menu>Setting>Advance Setting>Meter/CT Settings>Meter/CT Check**
 - » If meter is connected, please set the connection of Meter through the setting path: **Menu>Setting>Advance Setting>Meter/CT Settings.**

NOTICE!

- When the meter or CT is correctly connected, the meter/CT power displays on the METER/CT check interface; when the connection method is wrong, **Meter Fault** displays on this interface.

8.3 Checking after Power-on

- a. Check whether the system has any abnormal noise.
- b. Check whether the indicator lights report an error and check the system for alarm through the cabinet screen
- c. Check the running status of the system through the cabinet screen.

8.4 Operation of Lockable DC Switch (for Australia Version Only)

NOTICE!

- The Australian version DC switch is a lockable DC switch to prevent accidental switching on during maintenance, the lock needs to be prepared by the user.

The lockable DC switch includes 3 states: ON, OFF, and OFF+Lock. The DC switch is in the OFF state by default.

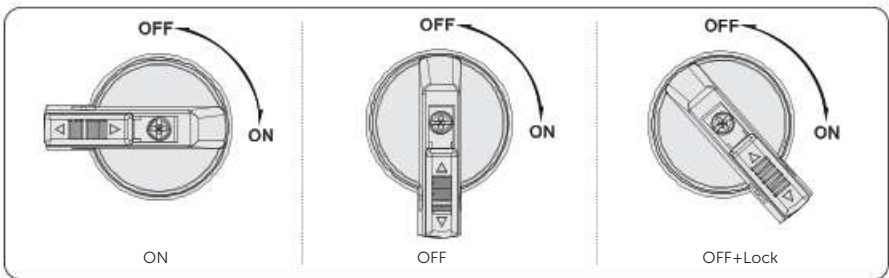

- Turn on the DC switch: rotate the DC switch from OFF state to ON state.

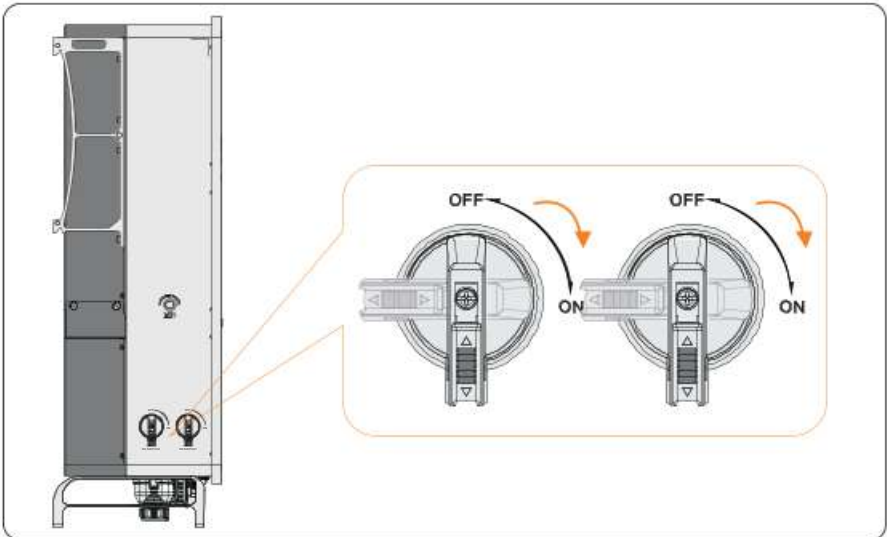

- Turn off the DC switch: rotate the DC switch from ON state to OFF state.

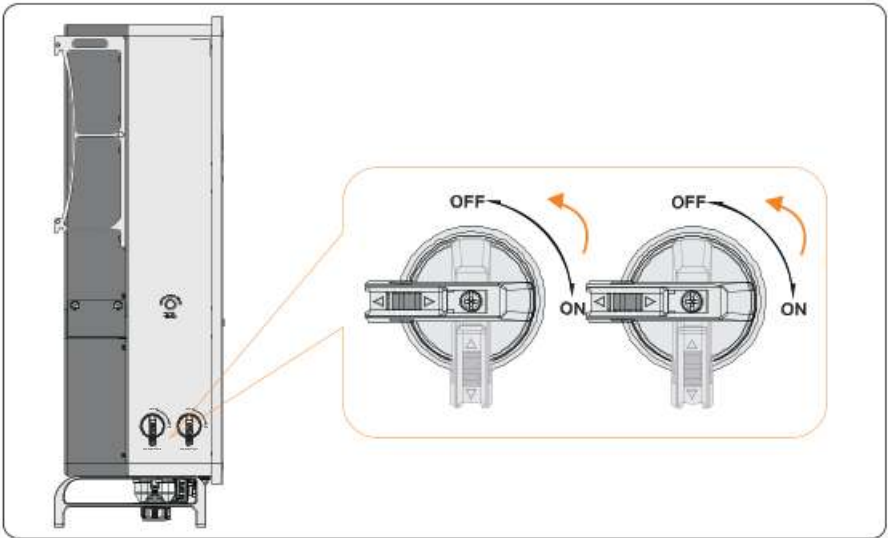

- Lock the DC switch
 - a. Rotate the DC switch to OFF state, then rotate the DC switch to the left side;
 - b. Push the position indicated by the arrow upward (as shown in the diagram below).
 - c. (Optional) After pushing the position upward, choose to lock the DC switch with a lock.

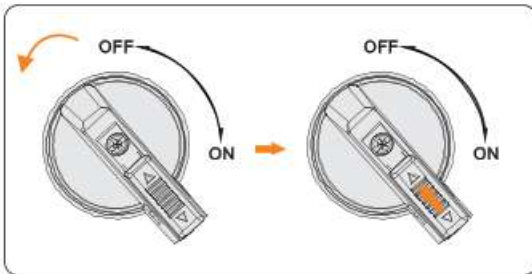

- Unlock the DC switch
 - a. Remove the lock. (If any);
 - b. Push the position indicated by the arrow down (as shown in the diagram below);
 - c. Wait for it to return to OFF state.

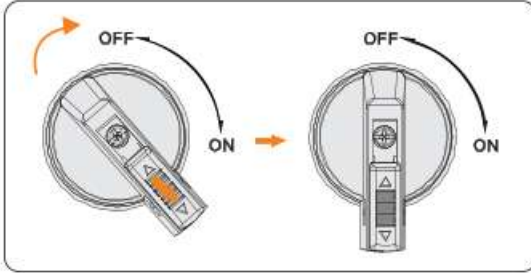

9 System Configuration

9.1 Operation on Inverter LCD

9.1.1 Introduction of Control Panel

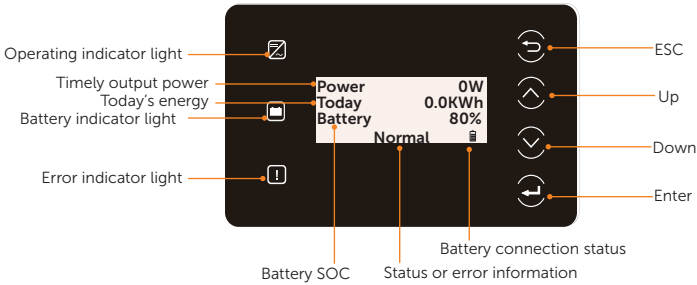





Figure 9-1 Control Panel

- In a normal state, the "Power", "Today" and "Battery" information will be displayed. You can press the keys to switch information.
- In an error state, the fault message and error code will be displayed, please refer to "11.3 Troubleshooting" for corresponding solutions.

Table 9-1 Definition of keys

Key	Definition
 ESC key	Exit from the current interface or function
 Up key	Move the cursor to the upper part or increase the value
 Down key	Move the cursor to the lower part or decrease the value
 Enter key	Confirm the selection

9.1.2 Introduction of Menu Interface

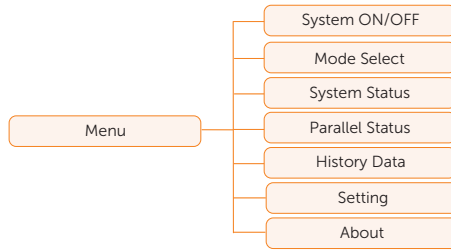

NOTICE!

This section only introduces the necessary inverter related LCD operations after the system is powered on, for the complete operations on inverter LCD, please refer to the *X3-AELIO Series User Manual*.

9.1.3 Setting

Settings includes User Settings and Advanced Settings.

User setting

Setting path: **Menu>Setting ("0 0 0 0")>User Setting**

NOTICE!

The default password for **User Setting** is "0 0 0 0".

- Setting Date & Time

You can set the current date and time of the installation site.

The display format is "2023-06-16 14:00", in which the first four numbers represent the year (e.g. 2000~2099); the fifth and sixth numbers represent the month (e.g. 01~12); the seventh and the eighth numbers represent the date (e.g. 01~31). The remaining numbers represent the time.

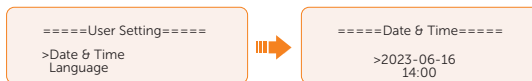

- Setting Language

This inverter provides multiple languages for customers to choose, such as English, Deutsch, Francais, Polskie, Espanol, Português. The default language is English.

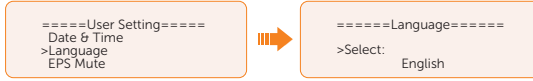

Advance setting

Setting path: **Menu>Setting>Advance Setting**

NOTICE!
<p>Property losses or system damage due to unauthorized access to adjustable parameters.</p> <ul style="list-style-type: none">• All the adjustable parameters including safety code, grid parameter, export control, etc can be modified under the permissions of installer password. Unauthorized use of the installer password by unauthorized persons can lead to incorrect parameters being input, resulting in power generation loss or violation of local regulation. Get the installer password from the dealer and never open the password to unauthorized person.

- Setting Safety Code

NOTICE!
<ul style="list-style-type: none">• The inverter cannot be connected to the grid before the safety code is correctly set. If there is any doubt about your safety code where the inverter installed, please consult your dealer or SolaX service for details.• The setup will vary from different safety codes.

Here you can set safety code according to different countries and grid-tied standards.

There are several standards to choose from, please refer to the LCD screen on the inverter. (May be changed or added without notice)

- » When you select safety code **CEI 0-21**, there will be additional **Self Test** option for setting under the path of **Menu>Setting>Advance Setting**.
- » When you select safety code **AS4777**, there will be additional **AS4777 Setting** option for **General Control** and **Export Control** under the path of **Menu>Setting>Advance Setting**.

- Setting Export Control

This function allows the inverter to control the amount of electricity output to the grid. The **User Value** set here must be less than the maximum value. If the user does not want to supply power to the grid, set **User Value** to "0".

NOTICE!

- Under Safety Code AS4777, **Export Control** is in the path of **Advance Setting > AS4777 Setting**. You can set the **Soft Limit** and **Hard Limit** of **Export Control** to control the power output to grid. Please refer to *X3-AELIO Series User Manual* for details.

```
====Export Control====
User Value
300000W
```

- Shut Down

This function enables remote control of the inverter switch status by disconnecting or connecting the external switch connected to the inverter.

- Enable/Disable**: Whether remote control is enabled.

```
===Shut Down===
Enable
```

- NO/NC**: NO (Always on) by default.
 - » **NO** (Always on): When the switch is disconnected, the inverter works normally, and when the switch is connected, the inverter shuts down.
 - » **NC** (Always closed): When the switch is connected, the inverter works normally, and when the switch is disconnected, the inverter shuts down.

```
===Shut Down===
>Enable
NO
```

- If the inverter is connected externally to an NS protection device to disconnect the inverter when necessary to protect the system, operate as follows:
 - » When the Inverter is Used Standalone:

Connect the dry contact to Pin3 and Pin4 of DIO port of COM2, with, and enable "ShutDown > Enable > NC".

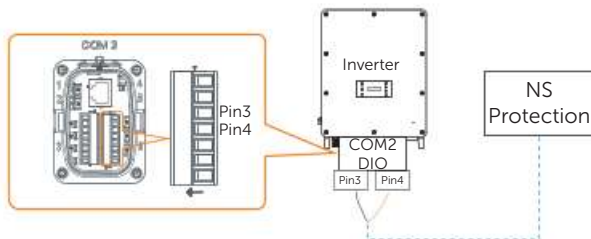

Figure 9-2 Connection diagram for NS Protection

- » When Running in Parallel:

The external NS protection device only needs to be connected to the Master inverter, with settings the same as those for standalone use.

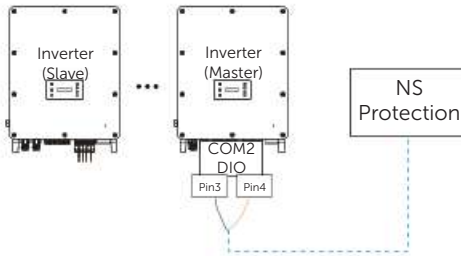

Figure 9-3 Connection diagram for NS Protection in parallel

- Setting Internal485

You can communicate with other SolaX equipment, such as EMS through **Internal485**.

- Select and enter **Internal485** interface;
- Select the equipment which needs to be connected and set the corresponding Baud Rate and Address. Take EMS as an example.



NOTICE!

- When two equipments need to be connected at the same time, the baud rate and address of the two equipments shall be set to the same.
- The baud rate of the EMS1000 is 115200.

- Check the connecting status.

9.2 Inverter Screen Cover Installation

After the inverter is well installed on the wall or on the cabinet, all cables are wired on the inverter, the process of powering on and powering off is checked and all necessary Settings are set on the inverter LCD screen, the inverter screen cover should be installed. Here below the inverter installed on the cabinet is taken for an example. Wall-mounting inverter shares the same screen cover installation method.

Step 1: Put the inverter screen cover (part V3) on the inverter and secure the cover on the two sides of the inverter with M4*10 screws (part U3) (Torque: 1.6 ± 0.1 N·m).

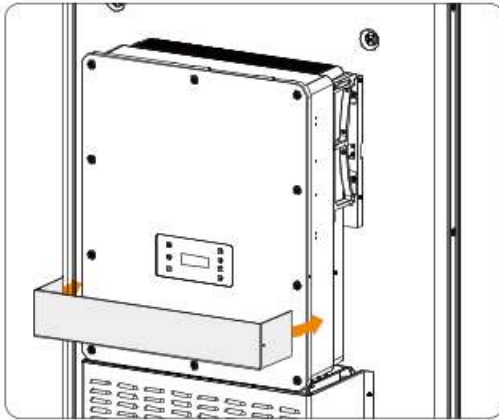

Figure 9-4 Putting the screen cover on the inverter

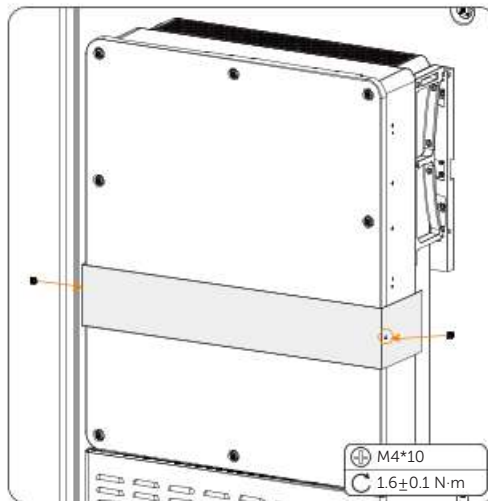

Figure 9-5 Securing the cover with the inverter

9.3 Operation on Cabinet Screen

Gently and correctly guide the key (part R) into the keyhole, and then turn it clockwise to unlock the screen door.

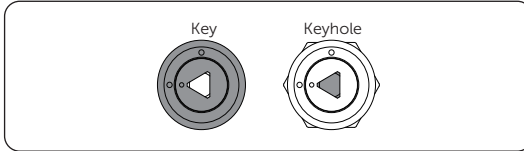

Figure 9-6 Correct position

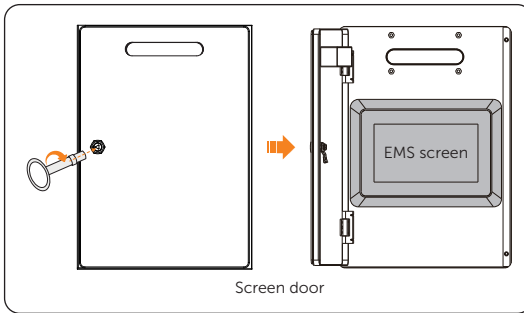

Figure 9-7 Unlocking screen door

9.3.1 Logging in

On the login screen, enter the username and password, and then tap **Login**.

Admin and user accounts are supported.

Table 9-2 Account information

Username	Password	Remarks
admin	EMS Registration No.	The password cannot be modified
user	123456 by default	The password can be modified on EMS1000 webpage.

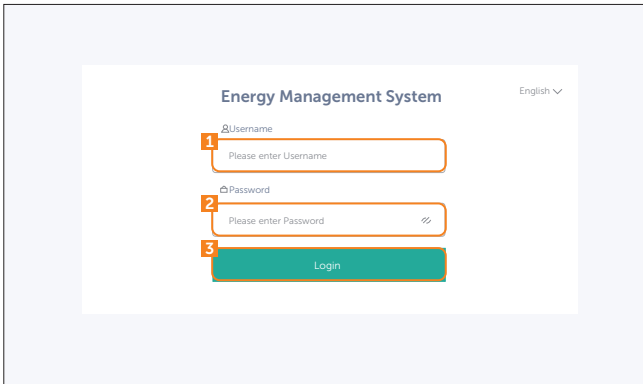

Figure 9-8 Logging in to the screen

After logging into the user account, you can obtain the administrator account password by tapping **Data > EMS > EMS Registration No.**, and log in the admin account after log out.



Figure 9-9 Viewing EMS Registration No.

Table 9-3 Parameter description

Parameter	Value Range	Description
COM Port	1-8	Number of RS485 terminal of EMS1000 that the inverter is connected to. For example, if the inverter is connected to the 8th RS485 terminal of the Device, the Serial Num is 8.
Connected device qty	1-20	Number of inverters that EMS1000 will be connected to. Up to 20 inverters can be connected.
Address allocation	<ul style="list-style-type: none"> Manual Auto 	<ul style="list-style-type: none"> Auto: In this mode, EMS1000 will automatically assign and recognize an RTU address for your inverter. Manual: In this mode, you will need to manually modify the Modbus address.
Start addr	/	The minimal Modbus address For manual address allocation, enter the minimal address that is configured for the inverter; For auto address allocation, enter 1.

After the inverter is successfully added, the inverter and the meter that it is bound to will be displayed on the device list. If EMS1000 identifies other devices in the cabinet such as battery and IO module, these devices will also be displayed on the screen.

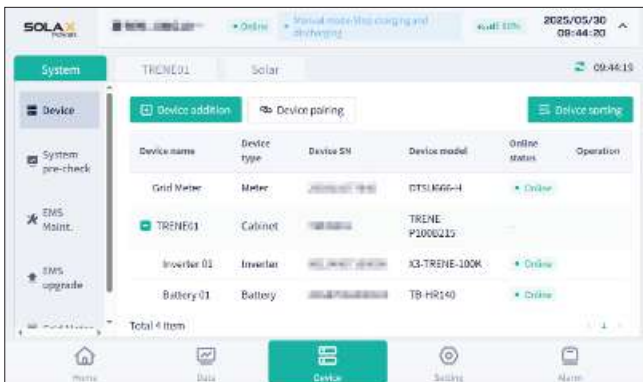

Figure 9-12 Adding inverter successfully

Step 3: You can set the the inverter through the **remote settings**, the initial password is 2014. For your account security, please change it after the first setting.

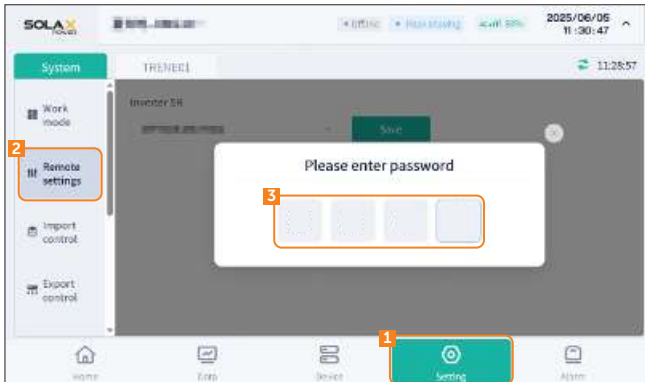

Figure 9-15 Remote settings

10 SolaXCloud App

10.1 Introduction of SolaXCloud

SolaxCloud is an intelligent management platform for home energy, which integrates energy efficiency monitoring, device management, data security communication and other integrated capabilities. While managing your home energy device, it helps you optimize the efficiency of electricity consumption and improve the revenue of power generation.

10.2 Operation Guide on SolaXCloud App

10.2.1 Downloading and Installing App

Method 1: Scan the QR code below to download the App.

The QR codes are also available on the login page of our official website (www.solaxcloud.com).



Figure 10-1 QR code

Method 2: Search for **SolaXCloud** in Apple Store App or Google Play, and then download the App.

10.2.2 Operation on the SolaXCloud App

For instructions on the related operations, see the online documents on the SolaXCloud App.

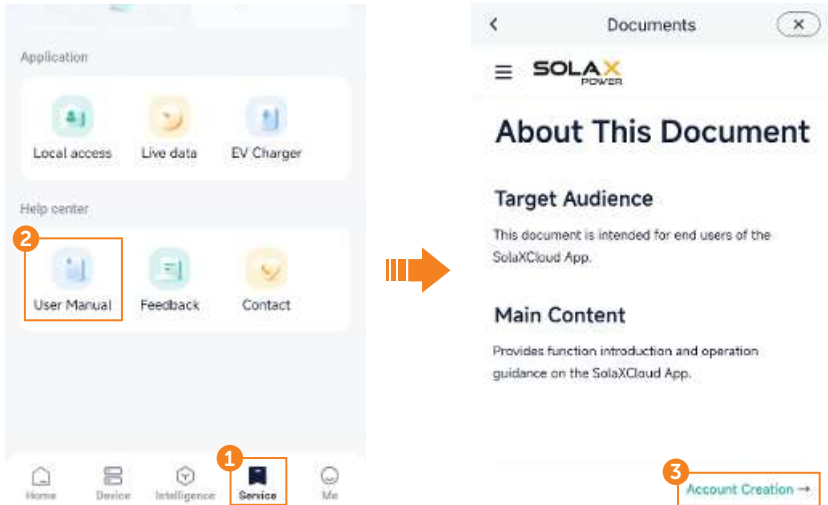

Figure 10-2 Online help on SolaXCloud

NOTICE!

- The screen shots in this chapter correspond to the SolaXCloud App V6.5.1, which might change with version update and should be subject to the actual situations.

11 Troubleshooting and Maintenance

11.1 Power Off



- Check whether the system is still running before power off. Do not power off if the device is "under load".

Regarding the detailed location of the modules in the cabinet, please refer to "[Figure 8-1 Location of modules](#)".

There are two circumstances: 1. Normal power off; 2. Emergency power off.

Normal Power Off

Step 1: Inverter power off.

- a. Set **OFF** in the **System ON/OFF** on the inverter LCD screen.
- b. Turn off the inverter system button.
- c. Turn off the AC breakers between the inverter and the grid & EPS load.
- d. Rotate the DC switch1 and DC switch2 to **OFF** position.

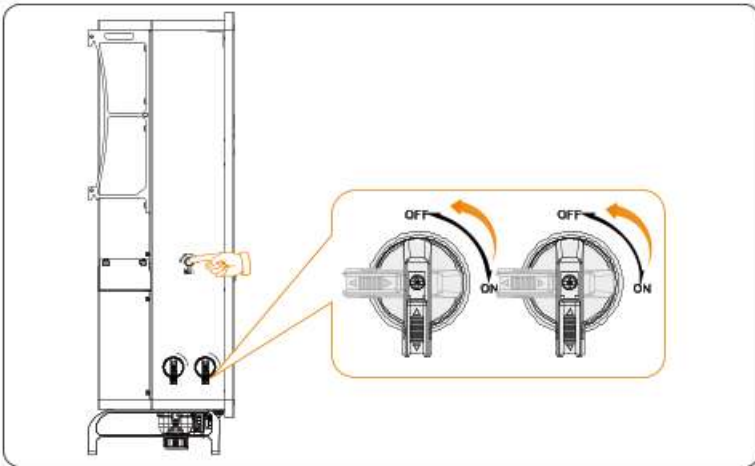

Figure 11-3 Shutting down the inverter

Step 2: Open the front doors.

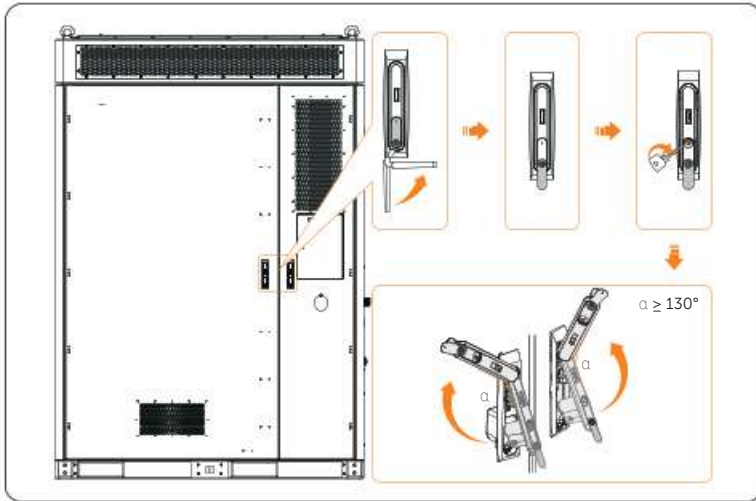

Figure 11-1 Opening front doors

Step 3: Gently press the power button, and rotate the disconnecter of the high-voltage box to "OFF".

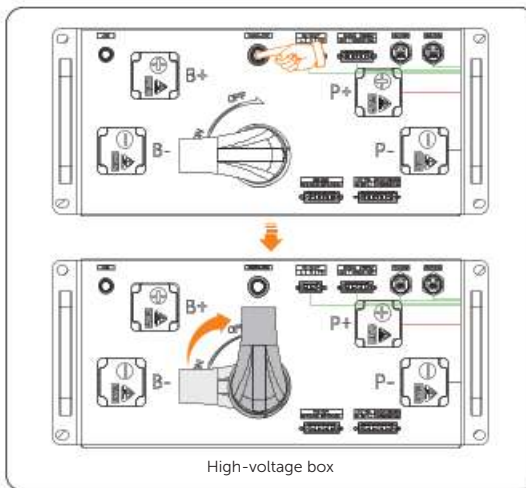

Figure 11-2 Shutting down the high-voltage box

Step 4: Hold and press the "Power on/off" button to power off the UPS.

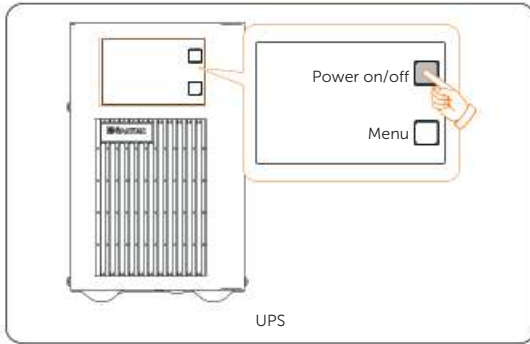

Figure 11-3 Holding and pressing button

Step 5: Shut down the distribution box.

- » Flip down the "SPD MCB" breaker;
- » Flip down the "HVAC MCB" breaker;
- » Flip down the "EPS" breaker;
- » Flip down the "APS" breaker;
- » Flip down the "UPS" breaker;
- » Rotate the switch on the distribution box 90° counter-clockwise to "OFF".

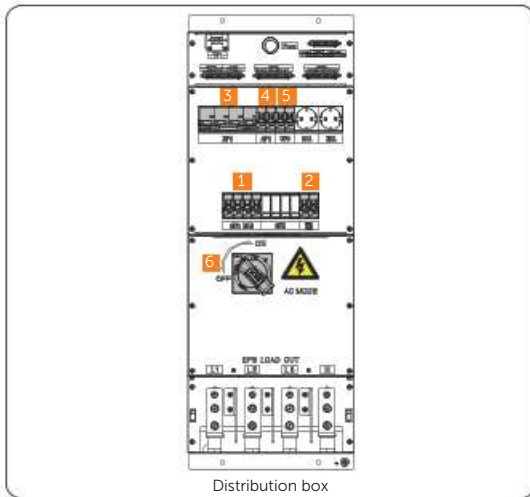

Figure 11-4 Shutting down sequence of distribution box

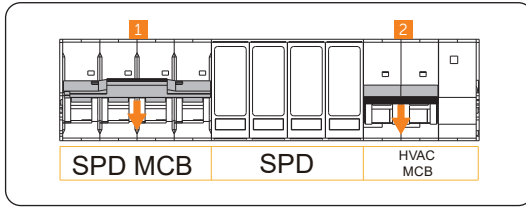

Figure 11-5 Flipping down breakers

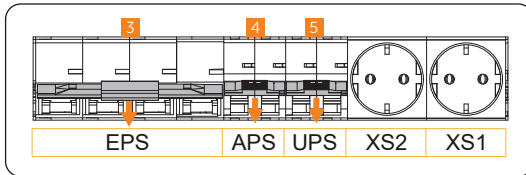

Figure 11-6 Flipping down breakers

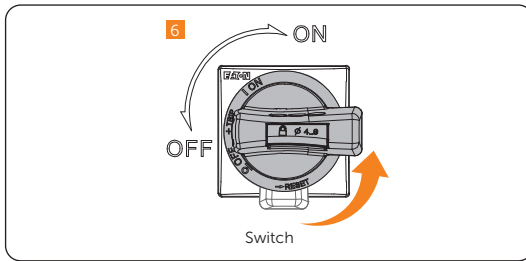

Figure 11-7 Rotating switch

! WARNING!

- The device may still have power and heat after turning off, which may cause electric shock and personal injuries. Therefore, please allow it to cool for at least 15 minutes and wear PPE before conducting maintenance.

Emergency Power Off

WARNING!

- Do not press the emergency stop button except for emergencies.
- Some modules inside the cabinet may still have power after pressing the emergency stop button, therefore, non-professionals are not allowed to operate them.

Step 1: Rotate the cover

Step 2: Press the emergency stop button.

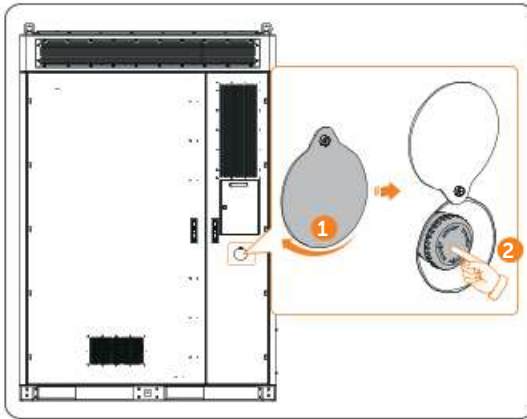

Figure 11-8 Pressing emergency stop button

NOTICE!

If it has been pressed, the emergency stop button must be reset before starting the device. The reset steps are shown as follows:

- a. Rotate the cover;
- b. Rotate the button according to the arrow direction shown on the button. Then the button will spring back to its original position.

11.2 Troubleshooting

11.2.1 Battery Cabinet Troubleshooting

This section lists the possible problems with the device, and provides information and procedures for identifying and resolving them. In case of any errors, check for the warnings or error messages on the system control panel or App, and then refer to the suggestions below. For further assistance, contact SolaX Customer Service. Please provide the model and SN of the cabinet, and be prepared to describe the system installation details.

Table 11-1 Troubleshooting list

Fault	Description and Diagnosis
UCellHi_4	<p>Single Cell Overvoltage Category IV</p> <ul style="list-style-type: none"> • Do not power on, and the charging current is limited to 0 A. If the relay does not receive a power-off instruction from the inverter, it will be turned off forcefully after 3 seconds. • Or contact SolaX for help.
UCellHi_5	<p>Single Cell Overvoltage Category V</p> <ul style="list-style-type: none"> • Do not power on, and the charging current is limited to 0 A. If the relay does not receive a power-off instruction from the inverter, it will be turned off forcefully after 1 second. • Or contact SolaX for help.
UCellLow_4	<p>Single Cell Undervoltage Category IV</p> <ul style="list-style-type: none"> • Do not power on, and the charging current is limited to 0 A. If the relay does not receive a power-off instruction from the inverter, it will be turned off forcefully after 3 seconds. • Or contact SolaX for help.
UCellLow_5	<p>Single Cell Undervoltage Category V</p> <ul style="list-style-type: none"> • Do not power on, and the charging current is limited to 0 A. If the relay does not receive a power-off instruction from the inverter, it will be turned off forcefully after 3 seconds. • Or contact SolaX for help.
UCellDiff	<p>Voltage difference fault</p> <ul style="list-style-type: none"> • Or contact SolaX for help.
HVBOver_4	<p>Overvoltage category IV of total voltage</p> <ul style="list-style-type: none"> • The charging current is limited to 0 A. If the relay does not receive a power-off instruction from the inverter, it will be turned off forcefully after 3 seconds. • Or contact SolaX for help.

Fault	Description and Diagnosis
HVBOver_5	<p>Overvoltage category V of total voltage</p> <ul style="list-style-type: none"> • The charging current is limited to 0 A. If the relay does not receive a power-off instruction from the inverter, it will be turned off forcefully after 1 second. • Or contact SolaX for help.
HVBLow	<p>Undervoltage category IV of total voltage</p> <ul style="list-style-type: none"> • The charging current is limited to 0 A. If the relay does not receive a power-off instruction from the inverter, it will be turned off forcefully after 1 second. • Or contact SolaX for help.
HVBLow	<p>Undervoltage category V of total voltage</p> <ul style="list-style-type: none"> • The charging current is limited to 0 A. If the relay does not receive a power-off instruction from the inverter, it will be turned off forcefully after 1 second. • Or contact SolaX for help.
PosRlyAdh	<p>Sticking contacts of main positive relay</p> <ul style="list-style-type: none"> • The charging current is limited to 0 A. If the relay does not receive a power-off instruction from the inverter, it will be turned off forcefully after 1 second. • Or contact SolaX for help.
PosRlyOpen	<p>Open circuit of main positive relay</p> <ul style="list-style-type: none"> • The charging current is limited to 0 A. If the relay does not receive a power-off instruction from the inverter, it will be turned off forcefully after 1 second. • Or contact SolaX for help.
TempHigh	<p>Overtemperature fault</p> <ul style="list-style-type: none"> • The charging current is limited to 0 A. If the relay does not receive a power-off instruction from the inverter, it will be turned off forcefully after 1 second. • Or contact SolaX for help.
TLineFlt_1	<p>Temperature sampling fault level 1</p> <ul style="list-style-type: none"> • Check if the temperature sensor is short-circuited. • Or contact SolaX for help.
TLineFlt_4	<p>Temperature sampling fault level 4</p> <ul style="list-style-type: none"> • The charging current is limited to 0 A. If the relay does not receive a power-off instruction from the inverter, it will be turned off forcefully after 3 seconds. • Or contact SolaX for help.

Fault	Description and Diagnosis
TempLow	<p data-bbox="336 244 561 263">Low-temperature fault</p> <ul data-bbox="336 277 932 373" style="list-style-type: none"> <li data-bbox="336 277 932 347">• The charging current is limited to 0 A. If the relay does not receive a power-off instruction from the inverter, it will be turned off forcefully after 1 second. <li data-bbox="336 355 612 373">• Or contact SolaX for help.
DsgOver_4	<p data-bbox="336 395 670 414">Discharge overcurrent fault level 4</p> <ul data-bbox="336 429 932 525" style="list-style-type: none"> <li data-bbox="336 429 932 499">• The charging current is limited to 0 A. If the relay does not receive a power-off instruction from the inverter, it will be turned off forcefully after 3 seconds. <li data-bbox="336 507 612 525">• Or contact SolaX for help.
DsgOver_5	<p data-bbox="336 537 670 557">Discharge overcurrent fault level 5</p> <ul data-bbox="336 571 932 667" style="list-style-type: none"> <li data-bbox="336 571 932 641">• The charging current is limited to 0 A. If the relay does not receive a power-off instruction from the inverter, it will be turned off forcefully after 1 second. <li data-bbox="336 649 612 667">• Or contact SolaX for help.
ChgOver_4	<p data-bbox="336 687 645 707">Charge overcurrent fault level 4</p> <ul data-bbox="336 721 932 817" style="list-style-type: none"> <li data-bbox="336 721 932 791">• The charging current is limited to 0 A. If the relay does not receive a power-off instruction from the inverter, it will be turned off forcefully after 3 seconds. <li data-bbox="336 799 612 817">• Or contact SolaX for help.
ChgOver_5	<p data-bbox="336 831 645 850">Charge overcurrent fault level 5</p> <ul data-bbox="336 865 932 960" style="list-style-type: none"> <li data-bbox="336 865 932 935">• The charging current is limited to 0 A. If the relay does not receive a power-off instruction from the inverter, it will be turned off forcefully after 1 second. <li data-bbox="336 943 612 960">• Or contact SolaX for help.
ICOMFault	<p data-bbox="336 981 620 1000">Internal communication fault</p> <ul data-bbox="336 1015 954 1110" style="list-style-type: none"> <li data-bbox="336 1015 954 1085">• Do not power on, and the charging current is limited to 0 A. If the relay does not receive a power-off instruction from the inverter, it will be turned off forcefully after 1 second. <li data-bbox="336 1093 612 1110">• Or contact SolaX for help.
OCOMFault	<p data-bbox="336 1125 625 1144">External communication fault</p> <ul data-bbox="336 1158 954 1254" style="list-style-type: none"> <li data-bbox="336 1158 954 1228">• Do not power on, and the charging current is limited to 0 A. If the relay does not receive a power-off instruction from the inverter, it will be turned off forcefully after 1 second. <li data-bbox="336 1236 612 1254">• Or contact SolaX for help.
MCOMFault	<p data-bbox="336 1275 757 1294">Intermediate network communication fault</p> <ul data-bbox="336 1308 943 1356" style="list-style-type: none"> <li data-bbox="336 1308 943 1327">• Do not power on, and the charging current is limited to 0 A. <li data-bbox="336 1335 612 1356">• Or contact SolaX for help.

Fault	Description and Diagnosis
UCellLineOpenFlt	<p>Voltage sampling fault</p> <ul style="list-style-type: none"> • The charging current is limited to 0 A. If the relay does not receive a power-off instruction from the inverter, it will be turned off forcefully after 1 second. • Or contact SolaX for help.
VoltSensorFlt	<p>Voltage sensor fault</p> <ul style="list-style-type: none"> • The charging current is limited to 0 A. If the relay does not receive a power-off instruction from the inverter, it will be turned off forcefully after 1 second. • Or contact SolaX for help.
CurrSensorFlt	<p>Current sensor fault</p> <ul style="list-style-type: none"> • Contact SolaX for help.
NegRlyAdh	<p>Sticking contacts of main negative relay</p> <ul style="list-style-type: none"> • Restart the device. • Or contact SolaX for help.
NegRlyOpen	<p>Open circuit of main negative relay</p> <ul style="list-style-type: none"> • Restart the device. • Or contact SolaX for help.
FlashFlt	<p>Flash fault</p> <ul style="list-style-type: none"> • Check if the external Flash communication is normal. • Or contact SolaX for help.
ChgReqFlt	<p>Charging request fault</p> <ul style="list-style-type: none"> • Check the device is properly charged. • Or contact SolaX for help.
InsFlt	<p>Insulation fault</p> <ul style="list-style-type: none"> • The charging current is limited to 0 A. If the relay does not receive a power-off instruction from the inverter, it will be turned off forcefully after 1 second. • Or contact SolaX for help.
SOCLowFlt	<p>Low SOC</p> <ul style="list-style-type: none"> • Check if the device is running out of power. • Or contact SolaX for help.
PreChgFailFlt	<p>External short-circuit fault</p> <ul style="list-style-type: none"> • The charging current is limited to 0 A. If the relay does not receive a power-off instruction from the inverter, it will be turned off forcefully after 1 second. • Or contact SolaX for help.

Fault	Description and Diagnosis
AFEProtectFlt	Battery's hardware protection fault <ul style="list-style-type: none"> • The charging current is limited to 0 A. If the relay does not receive a power-off instruction from the inverter, it will be turned off forcefully after 1 second. • Or contact SolaX for help.
SelfCheckFlt	Self-test fault <ul style="list-style-type: none"> • The charging current is limited to 0 A. If the relay does not receive a power-off instruction from the inverter, it will be turned off forcefully after 1 second. • Or contact SolaX for help.
LinkerTempHiFlt_3	Fault on overtemperature of high-voltage connector <ul style="list-style-type: none"> • Check whether the charge/discharge current is over 50% of rated charge/discharge current. • Or contact SolaX for help.
LinkerTempHiFlt_5	Fault on overtemperature of high-voltage connector <ul style="list-style-type: none"> • Check whether the charge/discharge current is over 50% of rated charge/discharge current. • Or contact SolaX for help.
BatLinkerTempHi_5	High-temperature fault of pole <ul style="list-style-type: none"> • The charging current is limited to 0 A. If the relay does not receive a power-off instruction from the inverter, it will be turned off forcefully after 3 seconds. • Or contact SolaX for help.
FanFault	Fan fault <ul style="list-style-type: none"> • Check whether any foreign objects stick to the fan. • Contact SolaX for help.
FuseSt	Fuse fault <ul style="list-style-type: none"> • Contact SolaX for help.
DCSwitch	DC switch fault <ul style="list-style-type: none"> • Contact SolaX for help.

11.2.2 Inverter Troubleshooting

This section contains information and procedures for resolving possible problems with the inverter, and provides the troubleshooting tips to identify and solve most problems that may occur. Please check the warning or fault information on the system control panel or on the App and read the suggested solutions below when error occurs. Contact SolaX Customer Service for further assistance. Please be prepared to describe the details of your system installation and provide the model and serial number of the inverter.

Table 11-1 Troubleshooting list

Error Code	Fault	Descriptions and Diagnosis
IE 01	TZ Protect Fault	<p>Overcurrent fault.</p> <ul style="list-style-type: none"> • Wait for a while to check if it returns to normal. • Disconnect PV+ PV- and batteries, reconnect. • If the system is in off-grid state, check if the power of EPS loads exceeds the maximum limit of the system or exceeds the current power supply of battery. • If the system fails to restore to its normal state, please contact SolaX for help.
IE 02	Grid Lost Fault	<p>Grid Lost Fault</p> <ul style="list-style-type: none"> • Check the grid connection status • Or contact SolaX for help.
IE 03	Grid Volt Fault	<p>Power grid voltage overrun</p> <ul style="list-style-type: none"> • Wait a moment, if the utility returns to normal, the system will reconnect. • Please check if the grid voltage is within normal range. • Or contact SolaX for help.
IE 04	Grid Freq Fault	<p>Grid overfrequency</p> <ul style="list-style-type: none"> • Wait a moment, If the utility returns to normal, the system reconnects. • Or contact SolaX for help.
IE 05	PV Volt Fault	<p>PV overvoltage</p> <ul style="list-style-type: none"> • Check the output voltage of the PV panel. • Check if the DC switch is OFF. • Or contact SolaX for help.
IE 06	Bus Volt Fault	<ul style="list-style-type: none"> • Press the ESC key to restart the inverter. • Check if the PV input open circuit voltage is in the normal range. • Check if the power of half-wave load exceeds the system limit. • Or contact SolaX for help.
IE 07	Bat Volt Fault	<p>Battery voltage fault</p> <ul style="list-style-type: none"> • Check if the battery input voltage is within normal range • Or contact SolaX for help.
IE 08	AC10mins Volt	<p>Grid voltage out of range in the last 10 minutes.</p> <ul style="list-style-type: none"> • The system will return to normal if the grid returns to normal. • Or contact SolaX for help.

Error Code	Fault	Descriptions and Diagnosis
IE 09	DCI OCP Fault	DCI overcurrent protection fault. <ul style="list-style-type: none"> • Wait for a while to check if it's back to normal. • Or contact SolaX for help.
IE 10	DCV OVP Fault	DCV EPS(Off-grid) overvoltage protection fault. <ul style="list-style-type: none"> • Wait for a while to check if it's back to normal. • Or contact SolaX for help.
IE 11	SW OCP Fault	Software detection of overcurrent Fault. <ul style="list-style-type: none"> • Wait for a while to check if it's back to normal. • Shut down photovoltaic, battery and grid connections. • Or contact SolaX for help.
IE 12	RC OCP Fault	Overcurrent protection fault. <ul style="list-style-type: none"> • Check the impedance of DC input and AC output. • Wait for a while to check if it's back to normal. • Or contact SolaX for help.
IE 13	Isolation Fault	Insulation fault <ul style="list-style-type: none"> • Please check the wire insulation for damage. • Wait for a while to check if it's back to normal. • Or contact SolaX for help.
IE 14	Temp Over Fault	Temperature out of range <ul style="list-style-type: none"> • Check if the ambient temperature exceeds the limit. • Or contact SolaX for help.
IE 15	Bat Con Dir Fault	<ul style="list-style-type: none"> • Battery direction fault • Check if the battery lines are connected in the opposite direction. • Or ask for help from the installer if it can not return to normal.
IE 16	EPS Overload	EPS(Off-grid) overload fault <ul style="list-style-type: none"> • Shutdown the high-power device and press the ESC key to restart the inverter. • Or contact SolaX for help if it can not return to normal.
IE 17	Overload Fault	On-grid mode overload fault <ul style="list-style-type: none"> • Shutdown the high-power device and press the ESC key to restart the inverter. • Or contact SolaX for help if it can not return to normal.

Error Code	Fault	Descriptions and Diagnosis
IE 18	BatPowerLow	<p>Bat Power Low</p> <ul style="list-style-type: none"> • Shutdown the high-power device and press the ESC key to restart the inverter. • Please charge the battery to a level higher than the protection capacity or protection voltage.
IE 19	BMS Lost	<p>Battery communication lost</p> <ul style="list-style-type: none"> • Check that the communication cable between the battery and the inverter are properly connected. • Or contact SolaX for help if it can not return to normal.
IE 20	Fan Fault	<p>Fan Fault</p> <ul style="list-style-type: none"> • Check for any foreign matter that may have caused the fan not to function properly. • Or contact SolaX for help if it can not return to normal.
IE 21	Low TempFault	<p>Low temperature fault.</p> <ul style="list-style-type: none"> • Check if the ambient temperature is too low. • Or contact SolaX for help if it can not return to normal.
IE 25	InterComFault	<p>Inter_Com_Fault</p> <ul style="list-style-type: none"> • Restart the inverter. • Or contact SolaX for help if it can not return to normal.
IE 26	INV EEPROM	<p>Inverter EEPROM Fault.</p> <ul style="list-style-type: none"> • Shut down photovoltaic, battery and grid, reconnect. • Or contact SolaX for help if it can not return to normal.
IE 27	RCD Fault	<p>Residual Current Device fault</p> <ul style="list-style-type: none"> • Check the impedence of DC input and AC output. • Disconnect PV + PV - and batteries, reconnect. • Or contact SolaX for help if it can not return to normal.
IE 28	Grid Relay Fault	<p>Electrical relay fault</p> <ul style="list-style-type: none"> • Disconnect PV+ PV- grid and batteries and reconnect. • Or contact SolaX for help if it can not return to normal.
IE 29	EPS Relay	<p>EPS(Off-grid) relay fault</p> <ul style="list-style-type: none"> • Disconnect PV+ ,PV-, grid and batteries and reconnect. • Or contact SolaX for help if it can not return to normal.

Error Code	Fault	Descriptions and Diagnosis
IE 30	PV ConnDirFault	<p>PV direction fault</p> <ul style="list-style-type: none"> • Check if the PV input lines are connected in the opposite direction. • Or contact SolaX for help if it can not return to normal.
IE 31	Battery Relay	<p>Charge relay fault</p> <ul style="list-style-type: none"> • Press the ESC key to restart the inverter. • Or contact SolaX for help if it can not return to normal.
IE 32	Earth Relay	<p>EPS(Off-grid) earth relay fault</p> <ul style="list-style-type: none"> • Press the ESC key to restart the inverter. • Or contact SolaX for help if it can not return to normal.
IE 100	PowerTypeFault	<p>Power type fault</p> <ul style="list-style-type: none"> • Upgrade the software and press the ESC key to restart the inverter. • Or contact SolaX for help if it can not return to normal.
IE 102	Mgr EEPROM Fault	<p>Mgr E2prom Error.</p> <ul style="list-style-type: none"> • Shut down photovoltaic ,battery and grid, and then reconnect. • Or contact SolaX for help if it can not return to normal.
IE 103	Fan4 Fault	<p>FAN4 Fault</p> <ul style="list-style-type: none"> • Check if the foreign objects stuck in the fan. • Or contact SolaX for help.
IE 104	NTC Sample Invalid	<p>NTC Sample Fault</p> <ul style="list-style-type: none"> • Make sure the NTC is properly connected and the NTC is in good condition. • Please confirm that the installation environment is normal • Or contact SolaX for help if it can not return to normal.
IE 107	CT Fault	<p>CT Fault</p> <ul style="list-style-type: none"> • Check if the CT is working properly • Or contact SolaX for help if it can not return to normal.
IE 109	Meter Fault	<p>Meter Fault</p> <ul style="list-style-type: none"> • Check if the meter is working properly • Or contact SolaX for help if it can not return to normal.

Error Code	Fault	Descriptions and Diagnosis
IE 110	BypassRelayFlt	<p>Bypass Relay Fault</p> <ul style="list-style-type: none"> • Press the ESC key to restart the inverter. • Or contact SolaX for help if it can not return to normal.
IE 111	FAN3 Fault	<p>FAN3 Fault</p> <ul style="list-style-type: none"> • Check if the foreign objects stuck in the fan. • Or contact SolaX for help.
IE 112	ARMParaComFlt	<p>ARM Parameter Communication fault</p> <ul style="list-style-type: none"> • Check that the communication cables of inverters are well connected and the baud rate of COMM setting of inverters are the same. • Or contact SolaX for help if it can not return to normal.
IE 113	FAN1 Fault	<p>FAN1 Fault</p> <ul style="list-style-type: none"> • Check if the foreign objects stuck in the fan. • Or contact SolaX for help.
IE 114	FAN2 Fault	<p>FAN2 Fault</p> <ul style="list-style-type: none"> • Check if the foreign objects stuck in the fan. • Or contact SolaX for help.
IE 115	20305Com Fault	<p>Com Fault</p> <ul style="list-style-type: none"> • Check the connection of the monitoring module, reinsert the module. • Please contact SolaX for help.
BE 01	BMS1_UCellOver BMS2_UCellOver	<p>Battery Error - Cell Overvoltage Fault</p> <ul style="list-style-type: none"> • Please contact SolaX for help.
BE 02	BMS1_UCellLow BMS2_UCellLow	<p>Battery Error - Cell Undervoltage Fault</p> <ul style="list-style-type: none"> • Please contact SolaX for help.
BE 03	BMS1_UCellDiff BMS2_UCellDiff	<p>Battery Error - Large Cell Differential Pressure Fault</p> <ul style="list-style-type: none"> • Please contact SolaX for help.
BE 04	BMS1_HVBOver BMS2_HVBOver	<p>Battery Error - Total Voltage Overvoltage Fault</p> <ul style="list-style-type: none"> • Please contact SolaX for help.
BE 05	BMS1_HVBLow BMS2_HVBLow	<p>Battery Error - Total Voltage Undervoltage Fault</p> <ul style="list-style-type: none"> • Please contact SolaX for help.
BE 06	BMS1_TempOver BMS2_TempOver	<p>Over temperature in battery system</p> <ul style="list-style-type: none"> • Please contact SolaX for help.

Error Code	Fault	Descriptions and Diagnosis
BE 07	BMS1_SelfCheck	Self check fault in battery system • Please contact SolaX for help.
	BMS2_SelfCheck	
BE 08	BMS1_PoRlyAdh	Battery Error - Main Positive Relay Adhesion Fault • Please contact SolaX for help.
	BMS2_PoRlyAdh	
BE 09	BMS1_PoRlyOpen	Battery Error - Main Positive Open Relay Fault • Please contact SolaX for help.
	BMS2_PoRlyOpen	
BE 10	BMS1_NeRlyAdh	Battery Error - Main Negative Relay Adhesion Fault • Please contact SolaX for help.
	BMS2_NeRlyAdh	
BE 11	BMS1_NeRlyOpen	Battery Error - Main Negative Open Relay Fault • Please contact SolaX for help.
	BMS2_NeRlyOpen	
BE 12	BMS1_PreChgFail	Battery Error - Battery Precharge Fault • Please contact SolaX for help.
	BMS2_PreChgFail	
BE 13	BMS1_CellSample	Battery Error - Battery Cell Sampling Fault • Please contact SolaX for help.
	BMS2_CellSample	
BE 14	BMS1_TempSample	Battery Error - Battery Temperature Sampling Fault • Please contact SolaX for help.
	BMS2_TempSample	
BE 15	BMS1_Sys	Battery Error - Battery System Fault • Please contact SolaX for help.
	BMS2_Sys	
BE 16	BMS1_DsgOver	Battery Error - Battery Discharge Overcurrent Fault • Please contact SolaX for help.
	BMS2_DsgOver	
BE 17	BMS1_ChgOver	Battery Error - Battery Charge Overcurrent Fault • Please contact SolaX for help.
	BMS2_ChgOver	
BE 18	BMS1_AFCom	Battery Error - Battery AFE communication Fault • Please contact SolaX for help.
	BMS2_AFCom	
BE 19	BMS1_InvCom	Battery Error - Extranet Communication Fault • Please contact SolaX for help.
	BMS2_InvCom	
BE 20	BMS1_MidCom	Battery Error - Intermediate Network Communication Fault • Please contact SolaX for help.
	BMS2_MidCom	

Error Code	Fault	Descriptions and Diagnosis
BE 21	BMS1_VoltSensor	Battery Error - Voltage Sensor Fault • Please contact SolaX for help.
	BMS2_VoltSensor	
BE 22	BMS1_IDRepet	Battery Error - Repetitive ID Fault • Please contact SolaX for help.
	BMS2_IDRepet	
BE 23	BMS1_TempLow	Battery Error - Low Temperature Fault • Please contact SolaX for help.
	BMS2_TempLow	
BE 24	BMS1_CurrSensor	Battery Error - Current Sensor Fault • Please contact SolaX for help.
	BMS2_CurrSensor	
BE 25	BMS1_Line	Battery Error - Open Power Cable Fault • Please contact SolaX for help.
	BMS2_Line	
BE 26	BMS1_Flash	Battery Error - Flash Fault • Please contact SolaX for help.
	BMS2_Flash	
BE 27	BMS1_AFEProtect	Battery Error - AFE Self-protection Fault • Please contact SolaX for help.
	BMS2_AFEProtect	
BE 28	BMS1_ChgReq	Battery Error - Charge Request Fault • Please contact SolaX for help.
	BMS2_ChgReq	
BE 29	BMS1_Ins	Battery Error - Battery Insulation Fault • Check that the battery is properly grounded and restart the battery. • Please contact SolaX for help.
	BMS2_Ins	
BE 30	BMS1_MCB	Battery Error - Micro Circuit Breaker Fault • Please contact SolaX for help.
	BMS2_MCB	
BE 31	BMS1_LinkTemp	Battery Error - Contactor Over Temperature Fault • Please contact SolaX for help.
	BMS2_LinkTemp	
BE 32	BMS1_BatLinker	Battery Error - Internal contact point Abnormally high in the battery • Please contact SolaX for help.
	BMS2_BatLinker	
BE 33	BMS1_Fan	Battery Error - Fan Fault • Check if the foreign objects stuck in the fan. • Or contact SolaX for help.
	BMS2_Fan	

11.3 Maintenance

Regular maintenance is required for the device. The table below lists the operational maintenance for expressing the optimum device performance. More frequent maintenance service is needed in the worse work environment. Please make records of the maintenance.



WARNING!

- Only qualified person can perform the maintenance for the device.
- Only use the spare parts and accessories approved by SolaX for maintenance.

Maintenance routine of battery cabinet

Table 11-2 Power on routine maintenance list

Check Item	Description	Interval Time
The operating status and environment of the system	<ul style="list-style-type: none"> • Check whether there is any damage to the distributed energy system, and the device is deformed. • Check whether there is any abnormal noise in the running system. • Check whether the temperature of the device shell is normal. Meanwhile, it is suggested to use a thermal imager or any other monitoring systems to identify signs of heat. • Check whether the surrounding is at normal humidity level, and there is any damage to the dust and air filters. <ol style="list-style-type: none"> a. Must ensure that the air intake is well ventilated. Otherwise, the battery pack failure will be caused due to overheating. b. Please gently open the door to prevent raising dust from the filter cotton. Otherwise, the smoke detector will alarm and give a command to the aerosol fire extinguisher to spray gas. 	Once a year
Cabinet screen	<ul style="list-style-type: none"> • Check whether the screen displays normally. • Check Alarm info on the screen. 	Once a year
Battery pack	<ul style="list-style-type: none"> • Check whether the fan of the battery pack is running normally • Check the appearance of the battery pack for damage or deformation. • Check whether there is any abnormal noise during operation. 	Once a year

Check Item	Description	Interval Time
Inverter	<ul style="list-style-type: none"> • Check whether the fan of the inverter is running normally • Check the appearance of the inverter for damage or deformation. • Check whether there is any abnormal noise during operation. 	Once a year
Air conditioner and cabinet fan	<ul style="list-style-type: none"> • Check that there are no potential hazards and contaminants around the device, and that there is no rubbish in the vicinity. • Check whether there is any abnormal noise, abnormal vibration and blade jamming in the running outdoor unit fan. 	Once a year
Smoke detector, temperature sensor, toxic gases detector	<ul style="list-style-type: none"> • Check the appearance and patrol lights visually. • Use special testing device to add smoke or heat on smoke detectors and temperature detectors to test the action of the detectors. 	Once a year
Aerosol	<ul style="list-style-type: none"> • Check the appearance of the aerosol: no deformation and nozzle integrity, confirm no agent leakage 	Once a year
Distribution box, UPS	<ul style="list-style-type: none"> • Check the appearance for damage or deformation. • Check whether there is any abnormal noise during operation. 	Once a year
EMS1000, I/O module	<ul style="list-style-type: none"> • Check whether the indicator lights normally. 	Once a year
Antennae	<ul style="list-style-type: none"> • Check whether the antenna is rusty due to salt spray, if so, the antenna needs to be replaced. 	Once a year
Safety function	<ul style="list-style-type: none"> • Check whether the emergency stop button and LED is in good working condition. • Check the stopping signal and communication by simulating the shutdown operation. • Check whether there are any damages to warning signs and other labels pasted on the device. If so, please replace them in time. 	Once a year

NOTICE!

The system must be shut down before perform the following maintenance.

Table 11-3 Power off routine maintenance list

Check Item	Description	Interval Time
Electrical connection	<ul style="list-style-type: none"> • Check whether the power cables are fastened securely. If not, please tighten them again according to the torque written in the document. • Check the electrical connection of battery packs, inverter, distribution box, UPS and other major devices for looseness and cable jacket damage, especially the cable jacket connecting with the metal parts. • Check whether the inverter, distribution box and UPS are reliably grounded. • Verify that the sealing caps on idle terminals of inverter are and not falling off. • Check whether the electrical insulation tape is in good condition and no peeling. 	The check shall be scheduled within one month after the first commissioning, and then can be scheduled every 12 months
Terminal and block connection	<ul style="list-style-type: none"> • Check whether there is any fading to the screws and copper bars. • Check whether the screws are fastened securely. If not, please tighten them again according to the torque written in the document. 	The check shall be scheduled within one month after the first commissioning, and then can be scheduled every 12 months
System cleaning	<ul style="list-style-type: none"> • Check whether the circuit boards and components are clean. • Check whether the heat sink of the inverter is covered with foreign objects. • Check and clean the filter to ensure that there is no dirty blockage of air conditioner and cabinet fan. • Clean the inverter cooling fans with a soft dry cloth or brush or replace it if necessary. • If necessary, clean the modules by air compressor. The maintenance period shall be shortened if the cabinet is installed in heavily polluted environments. 	Once a year

11.3.1 Disassembly and Clean of Air Conditioner Filter



- The air conditioner must be powered off before disassembly and clean of air conditioner.
- The device may still have power and heat after turning off, which may cause electric shock and personal injuries. Therefore, please allow it to cool for at least 5 minutes and wear PPE before conducting maintenance.

Step 1: Unscrew M6 screws, and orderly dismantle aluminum mesh plate, and black filter.

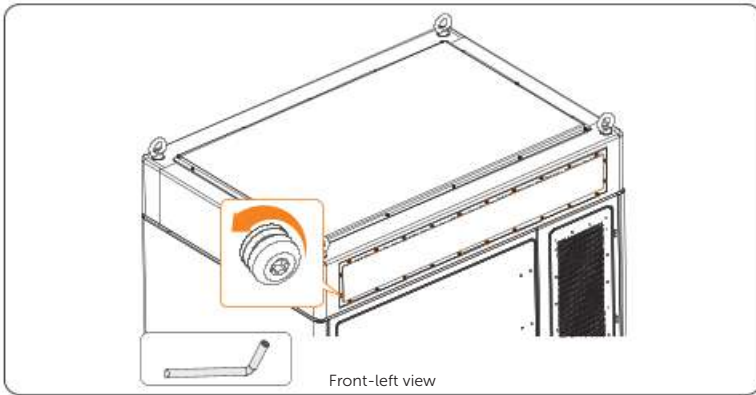

Figure 11-9 Unscrewing M6 screws

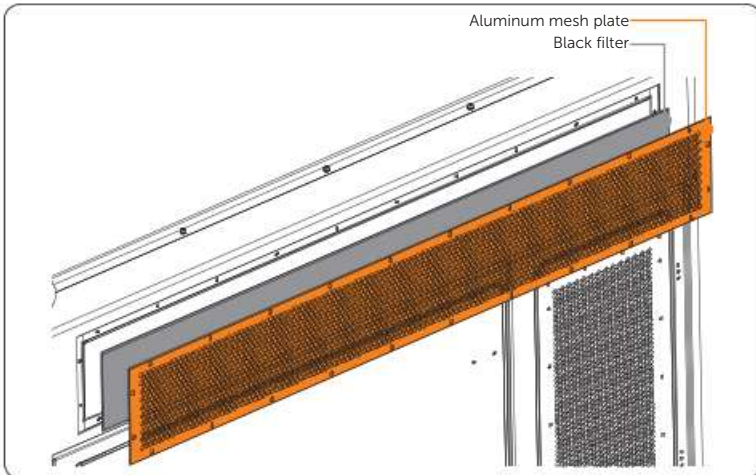

Figure 11-10 Dismantling

Step 2: Clean aluminum mesh plate, and replace the black filter.

Step 3: Orderly reinstall the black filter, and aluminum mesh plate.

Step 4: Insert and tighten M6 screws (x 24).

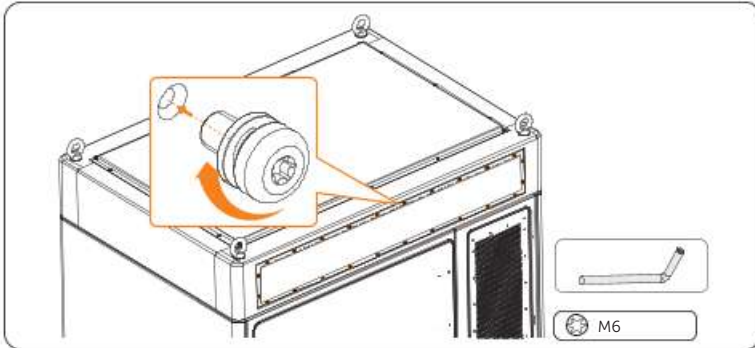

Figure 11-11 Tightening M6 screws

12 Decommissioning

12.1 Disposing of the Wasted and Damaged Battery Pack

Regarding the wasted or damaged battery packs, SolaX will not recycle them. Therefore, users can contact a recycling agency to dispose of them. The expenses incurred shall be borne by the users themselves.

Step 1: Contact a recycling agency, and estimate the expenses.

Step 2: The recycling agency will take full responsibility for dispose of the wasted or damaged battery packs.

12.2 Disposing of the Wasted and Damaged Inverter

Please dispose of the inverters or accessories in accordance with the disposal regulations for electronic waste which is applied at the installation site.

13 Technical Data

DC side

Model	AELIO-P50B200	AELIO-P60B200
Max. PV input power [kW]	100	120
Max. PV input voltage [V]	1000	
Start output voltage [V]	180	
Rated input voltage [V]	650	
MPPT voltage range [V]	160 ~ 950	
No. of MPP trackers / Strings per MPP tracker	5 (2 per MPPT)	6 (2 per MPPT)
Max. input current [A]	40	
Max. input short circuit current [A]	50	

AC side

Model	AELIO-P50B200	AELIO-P60B200
Rated AC output power [kW]	50.0	60.0
Rated AC output current [A]	75.8 @ 220V 72.5 @ 230V	91.0 @ 220V 87.0 @ 230V
Max. AC output apparent power [kVA]	55.0	66.0
Max. AC output current [A]	83.4 @ 220V 79.8 @ 230V	100.0 @ 220V 95.7 @ 230V
Rated grid voltage [V]	3/N/PE, 220/380, 230/400	
Rated grid frequency [Hz]	50/60	
Adjustable power factor range	1 (0.8 Leading ~ 0.8 Lagging)	
THDi (Rated power) [%]	< 3	

Battery

Model	AELIO-P50B200	AELIO-P60B200
Battery type	LFP	
Rated battery capacity [kWh]	200	
Rated battery voltage [V]	716.8	
Battery voltage range [V]	596.3 ~ 817.6	
Discharge depth [%]	90	
Rated charge/discharge current [A]	140	
Max charge/discharge current [A]	160 (80 × 2)	

General parameter

Model	AELIO-P50B200	AELIO-P60B200
Dimensions (with Inverter) (W×H×D) [mm]	2070 × 2420 × 1200	
Dimensions (without Inverter) (W×H×D) [mm]	1680 × 2420 × 1200	
Weight (with Inverter) [kg]	2800	
Weight (without Inverter) [kg]	2700	
Operating ambient temperature range [°C]	-30 ~ 50	
Relative humidity (Non-condensing) [%]	0 ~ 100	
Max. operating altitude [m]	3000	
Cooling concept	Smart air cooling	
Ingress protection	Cabinet: IP55; Inverter: IP66	
Fire protection	Aerosol / Water	
Topology	Non-isolated	
Standard	IEC62619, IEC63056:2000, IEC61000, IEC62477-1, UN38.3, IEC 60730, IEC 60529, IEC 60068, VDE 2510-50, IEC62040, UL9540A	

14 Appendix

14.1 Requirements for OT/DT Terminal

For different types of cables, select proper terminals and additional components for connection.

CAUTION!

- Do not connect the aluminum wiring terminal directly to the terminal block or copper bar in case of electrochemical corrosion, which might affect the reliability of cable connection.
- While using an aluminum wiring terminal, copper washer, and aluminum washer, pay special attention to the position of the two washers. The copper washer shall make contact with the terminal block, and the aluminum washer shall make contact with the aluminum wiring terminal.

NOTICE!

- The copper-to-aluminum wiring terminal used in scenario 3, and aluminum wiring terminal, copper washer, and aluminum washer used in scenario 4 must comply with the requirements in IEC61238-1.

Table 14-1 Terminal requirements for different types of cables

Scenario	Cable Type	Wiring Terminal Type	Figure Illustration
1	Copper cable	Copper wiring terminal	
2	Copper-clad aluminum cable	Copper wiring terminal	

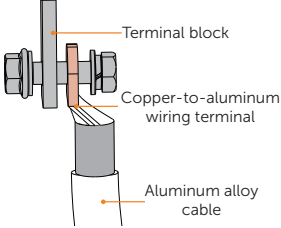
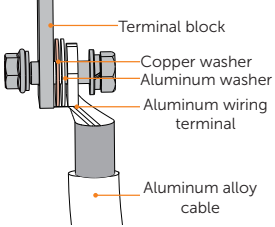
Scenario	Cable Type	Wiring Terminal Type	Figure Illustration
3	Aluminum alloy cable	Copper-to-aluminum wiring terminal	 <p>Terminal block</p> <p>Copper-to-aluminum wiring terminal</p> <p>Aluminum alloy cable</p>
4	Aluminum alloy cable	<ul style="list-style-type: none">• Aluminum wiring terminal• Copper washer• Aluminum washer	 <p>Terminal block</p> <p>Copper washer</p> <p>Aluminum washer</p> <p>Aluminum wiring terminal</p> <p>Aluminum alloy cable</p>

14.2 How to Repaint the Cabinet

Check the paint damage on the surface of the cabinet, with details below:

- For light scratches or small areas of stubborn stains, please see “14.2.1 Light Scratches & Small Areas of Stubborn Stains” to treat them.
- If the deep scratches or large areas of stubborn stains can be treated by users, please refer to “14.2.2 Deep Scratches and Large Areas of Stubborn Stains”.
- If the damaged area is too large and cannot be treated, please contact the after-sale personnel for assistance.

WARNING!

- If the cabinet is installed outdoors without shield, do not repaint it in rainy, snowy, windy, or stormy days.

NOTICE!

- Use paint of pantone11-4202TPG color.
- For light scratches and small areas of stubborn stains, spray paint and hairbrush are recommended.
- For deep scratches or large areas of stubborn stains, oil paint and paint sprayer are recommended.

14.2.1 Light Scratches & Small Areas of Stubborn Stains

This solution applies to light scratches without reaching the steel substrate and stubborn stains on the surface.

Tools and materials required

Prepare tools and enough materials according to actual conditions.

Table 14-2 Tools and materials

No.	Tool/Material	No.	Tool/Material
1	Spray/oil paint	2	Fine sandpaper
3	Anhydrous ethanol	4	Cotton cloth
5	Hairbrush (for small scratched area)	6	Spray paint (if there is a large area of light scratch, paint sprayer is recommended.)

Repainting procedure

Step 1: Gently sand the scratched area with a fine sandpaper to remove rust and stains on the surface.

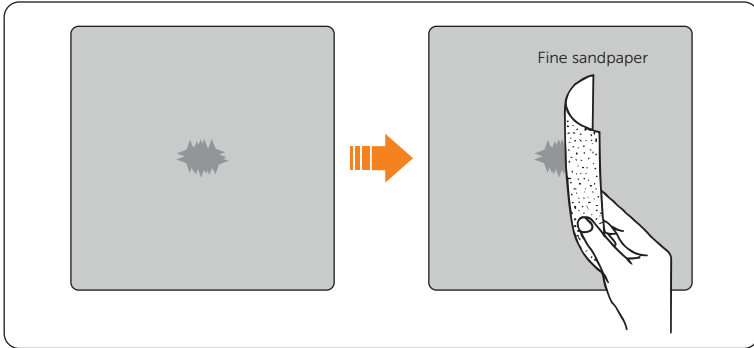

Figure 14-1 Sanding the scratched area

Step 2: Moisten a cotton cloth with anhydrous ethanol, wipe the scratched area with it to remove dust and dirt, and then use a dry cotton cloth to wipe the area dry.

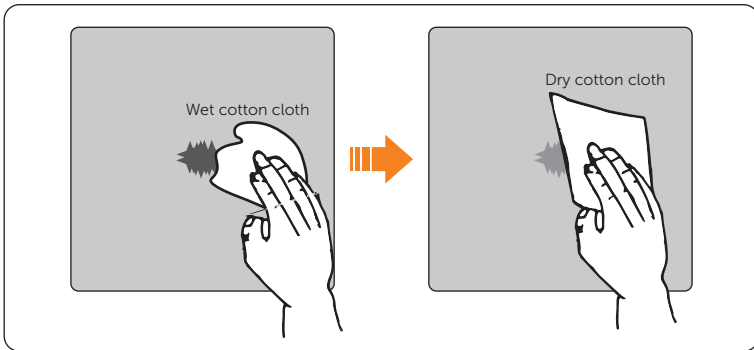

Figure 14-2 Cleaning the scratched area

Step 3: Use hairbrush or spray paint to apply paint to the surface of the scratched area until it is fully and evenly covered.

NOTICE!

- While applying paint, make sure the newly applied paint is thin and even, so that the scratched area can appear consistent and smooth on the surface.
- If there is color difference between the scratched area and the surroundings, cover the surrounding area with tape or paper in case of color contamination.

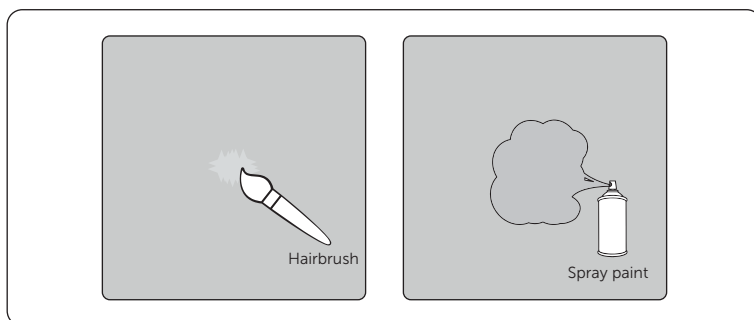

Figure 14-3 Applying paint

Step 4: After completing applying the paint, wait for around 30 minutes for the paint to get dry, and then check whether the repaired area meets the requirements.

NOTICE!

- The color of the repaired area shall be consistent with the surrounding area.
 - » Use a colorimeter to measure the color difference, of which Delta E shall be ≤ 3 .
 - » If the color cannot be measured by a colorimeter, make sure that there is no obvious color difference at the edges between the repaired area and the surrounding area, as well as no bumps, scratches, flakings, or breaks.
- For spray painting, we recommend painting for at least 3 times before pausing to check the effect, and then repeat spray painting and observing until it meets the requirements.

14.2.2 Deep Scratches and Large Areas of Stubborn Stains

This solution applies to deep scratches where the primer has been damaged and reach the steel substrate.

Tools and materials required

Prepare tools and enough materials according to actual conditions.

Table 14-3 Tools and materials

No.	Tool/Material	No.	Tool/Material
1	Spray/oil paint	2	Zinc-rich primer
3	Fine sandpaper	4	Anhydrous ethanol
5	Cotton cloth	6	Hairbrush (for small areas of deep scratches and stubborn stains)

No.	Tool/Material	No.	Tool/Material
7	Paint sprayer (for large areas of deep scratches and stubborn stains)		

Repainting procedure

Step 1: Gently sand the scratched area with a fine sandpaper to remove rust and stains on the surface.

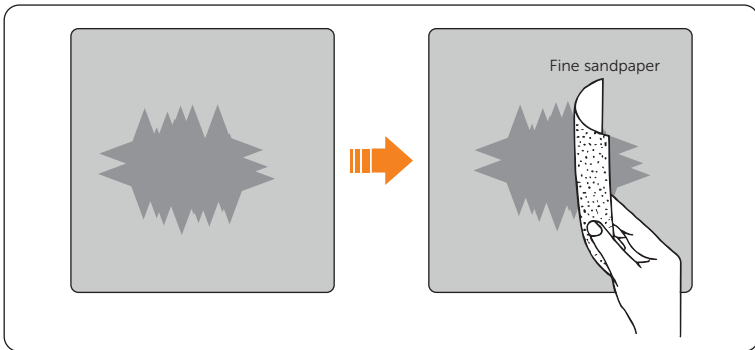

Figure 14-4 Sanding the scratched area

Step 2: Moisten a cotton cloth with anhydrous ethanol, wipe the scratched area with it to remove dust and dirt, and then use a dry cotton cloth to wipe the area dry.

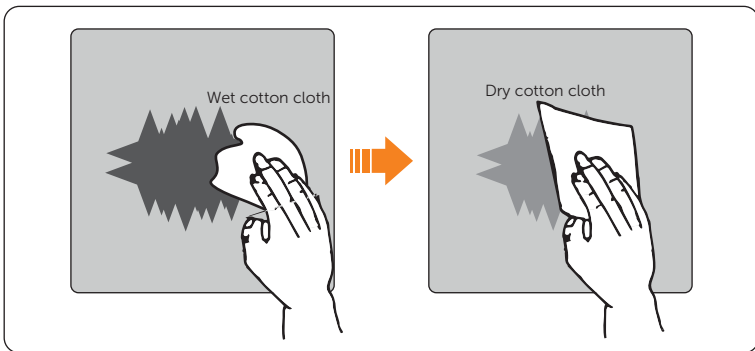

Figure 14-5 Cleaning the scratched area

Step 3: Use a paint spray to apply the zinc-rich primer to the scratched area.

NOTICE!

- If the steel substrate is visible on the scratched area, the zinc-rich primer must be applied first to entirely cover the substrate.
- Wait for the primer to get dry before applying the top coat to the scratched area.

Step 4: Use a paint spray to apply paint to the surface of the scratched area until it is fully and evenly covered.

NOTICE!

- While applying paint, make sure the newly applied paint is thin and even, so that the scratched can appear consistent and smooth on the surface.
- If there is color different between the scratched area and the surroundings, cover the surrounding area with tape or paper in case of color contamination.

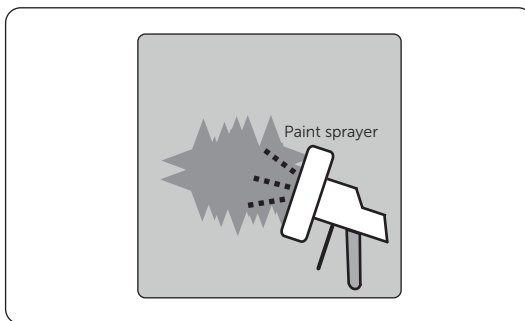

Figure 14-6 Applying paint

Step 5: After completing applying the paint, wait for around 30 minutes for the paint to get dry, and then check whether the repaired area meets the requirements.

NOTICE!

- The color of the repaired area shall be consistent with the surrounding area.
 - » Use a colorimeter to measure the color difference, of which Delta E shall be ≤ 3 .
 - » If the color cannot be measured by a colorimeter, make sure that there is no obvious color difference at the edges between the repaired area and the surrounding area, as well as no bumps, scratches, flakings, or breaks.
- For spray painting, we recommend painting for at least 3 times before pausing to check the effect, and then repeat spray painting and observing until it meets the requirements.

14.2.3 Logo & Pattern damaged, Dents or Dings

In this case, we recommend contacting a local spray painting company for customized treatment based on the actual conditions.

Table 14-4 Damage extent and recommended solution

No.	Damaged Area	Recommended Solution
1	<ul style="list-style-type: none">• Size < 100 mm²• depth < 3 mm	Use a poly-putty base to fix the dents and dings first, and then deal with them according to " Repainting Procedure " for Deep Scratches.
2	<ul style="list-style-type: none">• Size > 100 mm²• depth > 3 mm	Contact local supplier to make a plan for repair.

14.3 Micro-grid Application

14.3.1 Introduction of Micro-grid Application

Due to Islanding Effect, on-grid inverter is unable to work during off-grid. This characteristic makes user losing the on-grid inverter PV energy when off-grid. Micro-grid is the function that making hybrid inverter simulate the grid to active on-grid inverter during off-grid by connecting on-grid inverter to hybrid inverter's EPS terminal.

14.3.2 Wiring Connection Diagram

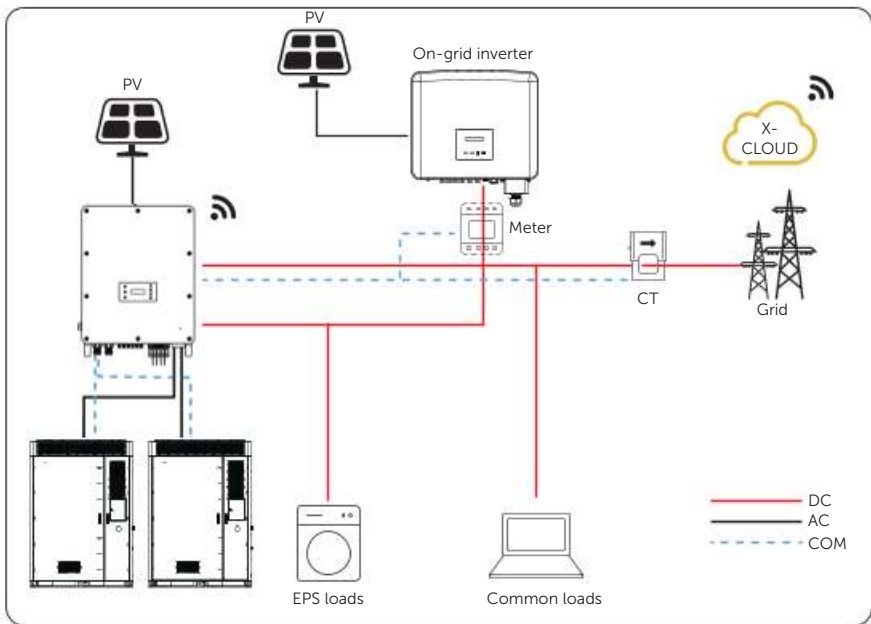

Figure 14-1 Micro-grid wiring connection

14.3.3 Working Modes

Grid on

- When PV is sufficient, the hybrid and on-grid inverters power the general and critical loads together. When there is surplus energy on the on-grid inverter, it will also charge the battery connected to the hybrid inverter.
- When PV is insufficient, the hybrid, on-grid inverter and grid power all the loads.

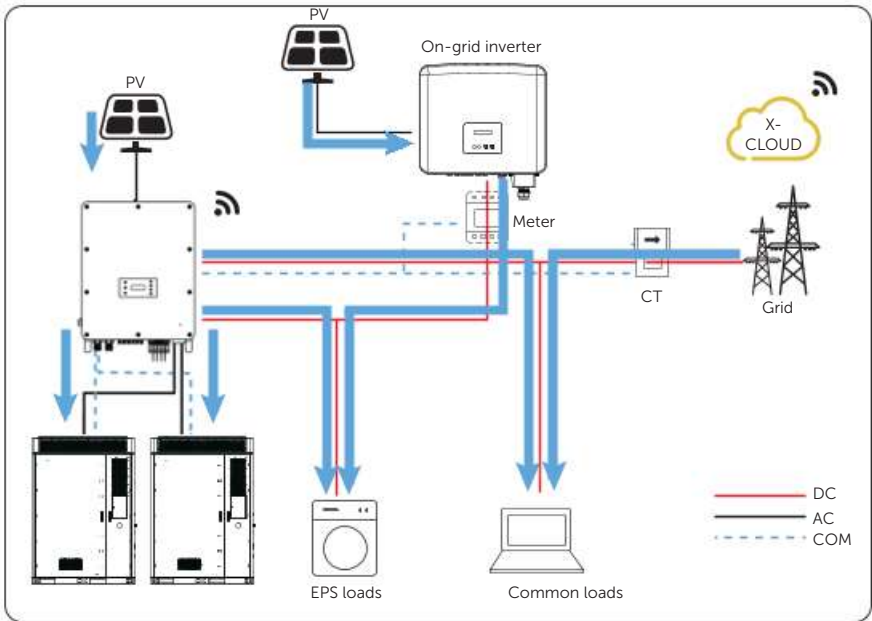

Figure 14-2 Power flowing when grid on and PV sufficient

Grid off

In this case, the hybrid inverter will simulate the grid so as to make the on-grid inverter can still work. Hybrid and on-grid inverter will power the EPS loads together. If there is surplus energy, it will charge the battery.

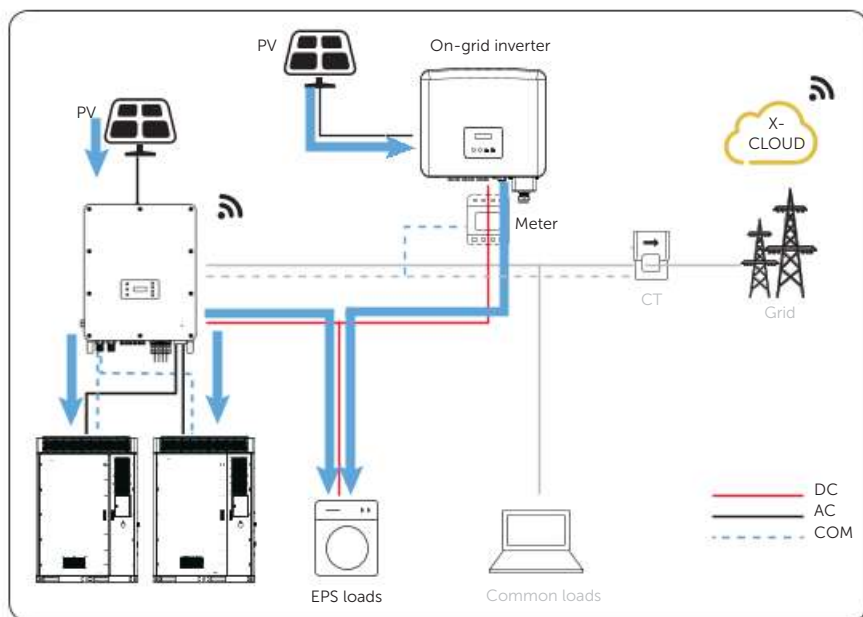

Figure 14-3 Power flowing when grid off

Notice for Micro-grid application

- Any brand of on-grid inverter that supports "frequency adaptation"
- On-grid inverter output power \leq Max hybrid inverter EPS output power
- On-grid inverter output power \leq Max battery charging power, refer to the table below:

NOTICE!

- Since X3-AELIO series inverter is unable to control the output power of on-grid inverter in grid connection mode, therefore X3-AELIO series inverter can not achieve zero export when loads power + battery charging power < on-grid inverter output power.

14.3.4 Cable Connection (Hybrid inverter)

Please refer to "7.2.2 AC Connection" for Grid and EPS connection on X3-AELIO series inverter.

14.3.5 Cable Connection (On-grid Inverter)

Please connect the AC cable of on-grid inverter to the EPS terminal of X3-AELIO series inverter through a circuit breaker. Please refer to the user manual of specific on-grid inverter.

14.3.6 Cable Connection (Meter)

To detect and monitor the power data generated from the on-grid inverter, you can install a meter on the on-grid inverter side. Otherwise, the relevant power data of on-grid inverter can not be monitored.

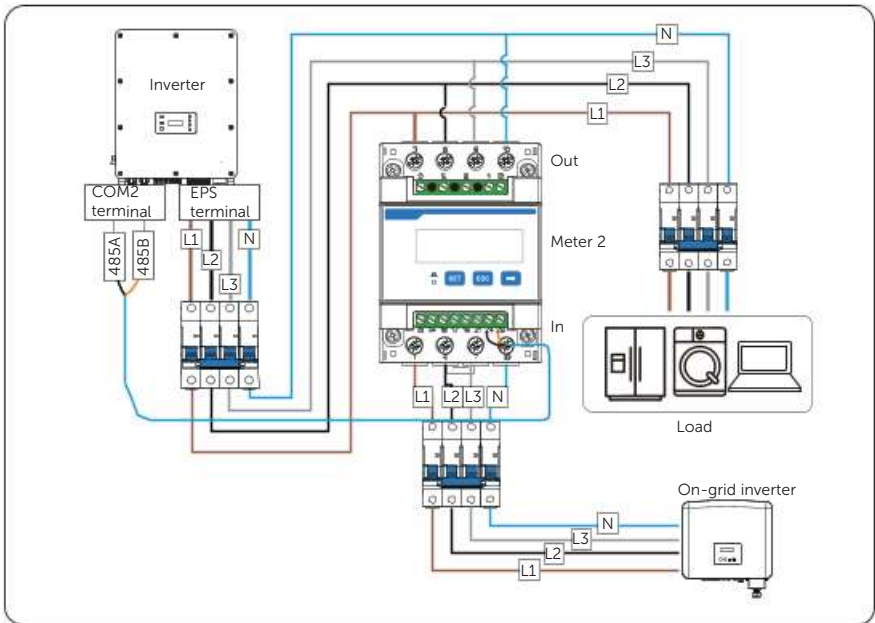

Figure 14-4 Connection diagram of Meter on EPS terminal

NOTICE!

- If one-to-two adapter for RJ45 terminal is used, it should be placed in a waterproof enclosure.

- Pin definition

Table 14-1 Pin definition for meter and CT

Application	For CT1			For meter		For CT2		
Pin	1	2	3	4	5	6	7	8
Assignment	CT_ R1_ CON	CT_ S1_ CON	CT_ T1_ CON	METER _485A	METER _485B	CT_ T2_ CON	CT_ S2_ CON	CT_ R2_ CON

- Meter/CT connection steps

Please refer to “14.4 CT/Meter Connection Scenarios” and meter/CT user manual for specific connection steps.

- Setting on the LCD

Setting path: **Menu>Setting>Advance Setting>Meter/CT Setting**

① For meter 1 and meter 2 solution (Meter 1 for grid connection, Meter 2 for EPS connection)

- Select and enter the **Meter/CT Setting** according the setting path.
- Set the address and direction of Meter 1: You can check the connection status in **Meter/CT Check**.



- Set the address and direction of Meter 2: You can check the connection status in **Meter/CT Check**.



- After connection succeeded, check the feed-in power of Meter 1 in the path of **Menu>System Status>Meter/CT** and check the output power (**Output Today** and **Output Total**) of Meter 2 in the path of **Menu>History Data>E_USERDEF**.

② For CT and meter 2 solution (CT for grid connection, Meter 2 for EPS connection)

- a. Select and enter the **Meter/CT Setting** according the setting path.
- b. The default device is CT and the status is enable by default. You can check the connection status in **Meter/CT Check**.
- c. Set the address and direction of Meter 2: You can check the connection status in **Meter/CT Check**.

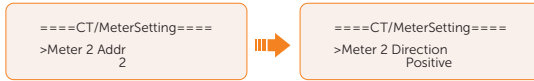

- d. After connection succeeded, check the feed-in power of Meter 1 in the path of **Menu>System Status>Meter/CT** and check the output power (**Output Today** and **Output Total**) of Meter 2 in the path of **Menu>History Data>E_USERDEF**.

14.4 CT/Meter Connection Scenarios

X3-AELIO inverter series can be connected to a single batch of CTs, a direct-connected meter, or a CT-connected meter, and also supports a Meter 2 function for you to monitor another power generation device at home.

Followings are the detailed wiring and setting procedures of these scenarios. For wiring procedure of the inverter CT/Meter port, see "[CT/Meter connection](#)".

14.4.1 Connection of CT

NOTICE!

- Do not place the CT on the N wire or ground wire.
- Do not put CT on the N line and L line at the same time.
- Do not place the CT on the side where the arrow points to the inverter.
- Do not place the CT on non-insulated wires.
- The cable length between CT and inverter should not exceed 10 meters.
- It is recommended to wrap the CT clip around in circles with insulating tape.

NOTICE!

- The CTs referred to in this section are the CT batch delivered with the inverter.

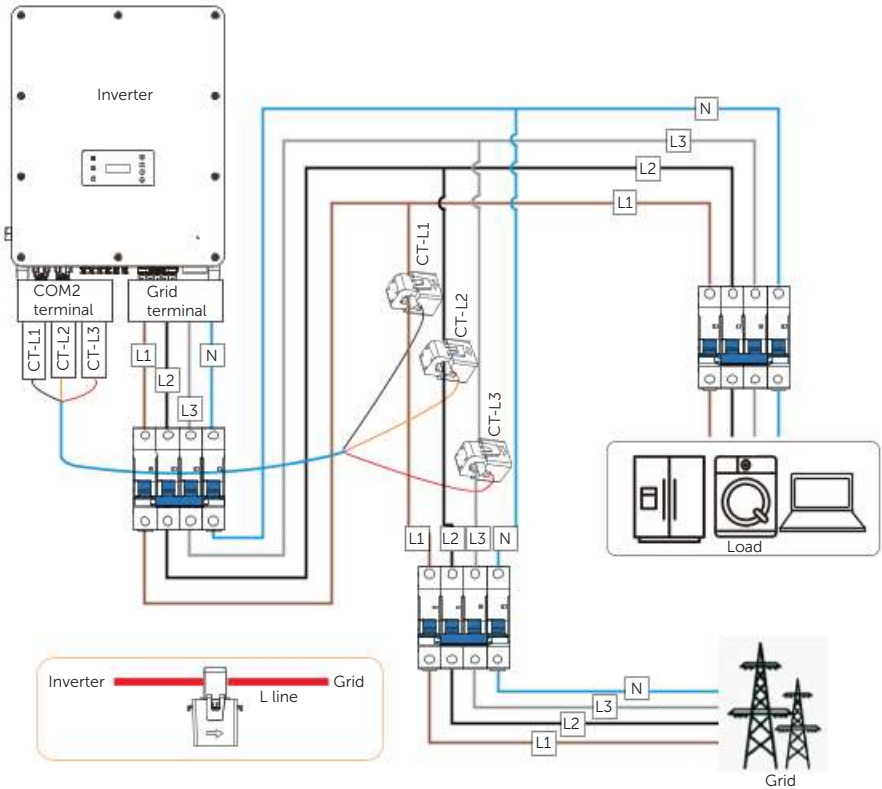

Figure 14-5 System wiring with CT

NOTICE!

- The arrow on the CT must point at the public grid.
- Markings on the CTs might be R, S and T or L1, L2 and L3. Make sure to clip CT-R/CT-L1 to the L1 wire, CT-S/CT-L2 to the L2 wire, and CT-T/CT-L3 to the L3 wire.
- The emergency load is connected to the EPS terminal of the inverter, which is not shown in the diagram.

Wiring procedure

Step 1: Clip CT_L1, CT_L2 and CT_L3 respectively onto the L1, L2 and L3 cables of the grid.

Make sure the arrow on the CTs is pointing to the grid side from the inverter.

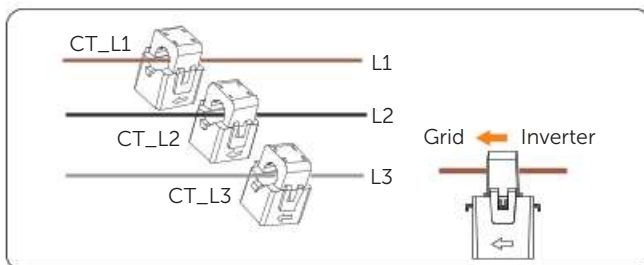

Figure 14-6 Clipping CTs to grid cables

Step 2: Use the RJ45 coupler to connect the extension communication cable and the batch of CTs.

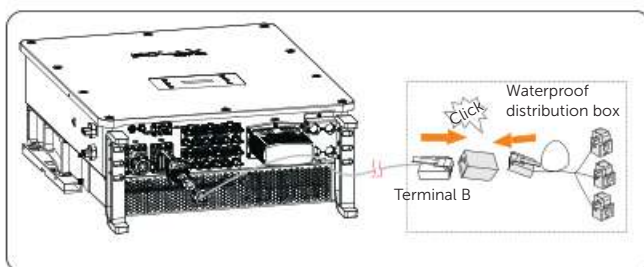

Figure 14-7 Connecting to CT

Setting procedure

After connecting CT to the inverter, set parameters for them on the inverter.

Step 1: Select **Advance Settings > Meter/CT Setting**.

Step 2: Enable CT, and then select the supported CT type.

You can check the connection status in **Meter/CT Check**. For details, see "[Setting Meter/CT Check](#)".

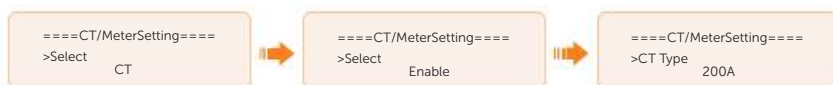

Figure 14-8 Setting CT for the inverter

14.4.2 Connection of Direct-connected Meter

NOTICE!

- The following figures take inverter with Meter DTSU666 as an example.
- Please make PE connection for Meter if the meter has ground terminal.

- Meter connection diagram

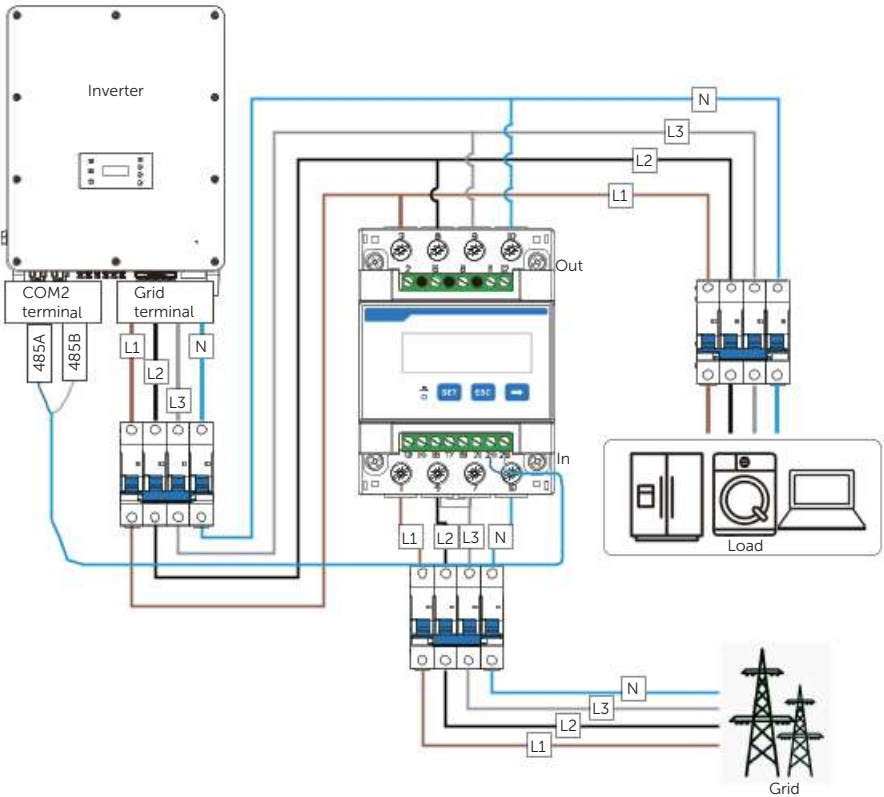

Figure 14-9 System wiring with direct-connected meter

NOTICE!

- For direct-connected meter, the current flow direction should be from grid to the inverter.
- Terminal 1, 4 and 7 of the meter must be connected to the grid side, and terminal 3, 6 and 9 be connected to the inverter side of the system. Otherwise, the system power data might be misread.

Meter terminal definition

Table 14-2 Terminal definition of SolaX direct-connected meter

Terminal No.	Definition	Description
1, 4, 7	UA*, UB*, UC*	Voltage input terminal of phase A, B and C, respectively connected to L1, L2 and L3 wire
3, 6, 9	UA, UB, UC	Voltage output terminal of the three phases, respectively connected to L1, L2 and L3 wire
10	UN	Connected to the N wire
24	RS485A	RS485 terminal A
25	RS485B	RS485 terminal B

Wiring procedure

Step 1: Strip around 10 mm wire insulation off the grid voltage cables, and then connect L1, L2 and L3 wires respectively to terminal 1 and 3, 4 and 6, 7 and 9, and N wire to terminal 10 of the meter.

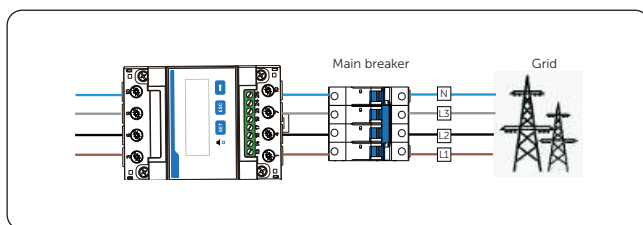

Figure 14-10 Connecting direct-connected meter to the grid

Step 2: Strip 15 mm wire insulation off the other end of the communication cable.

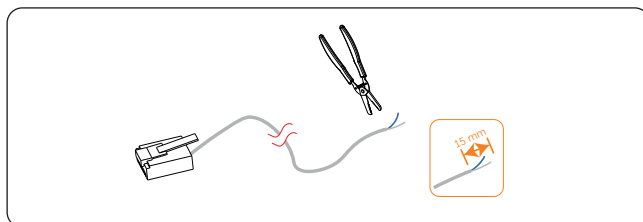

Figure 14-11 Stripping communication cable for meter

Step 3: Connect the conductors to terminal 24 and 25 of the meter.

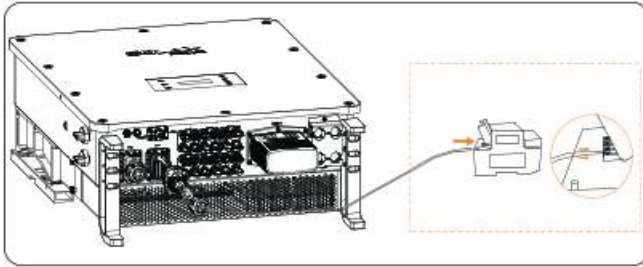

Figure 14-12 Connecting inverter to meter

Setting procedure

After connecting meter to the inverter, set parameters of the meter on the inverter.

Step 1: Select **Advance Settings > Meter/CT Setting**.

Step 2: Enable **Meter**, and then set **Meter1Addr** to **1** and **Meter1 Direction** to **Positive**.

You can check the connection status in **Meter/CT Check**. For details, see "[Setting Meter/CT Check](#)".

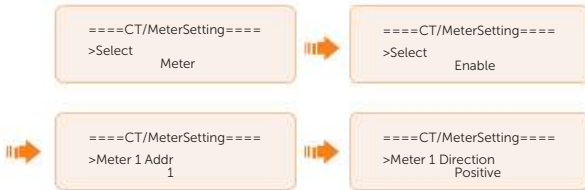

Figure 14-13 Setting meter for the inverter

14.4.3 Connection of CT-connected Meter

NOTICE!

- The following figures take inverter with Meter DTSU666-CT as an example.
- Please make PE connection for Meter if the meter has ground terminal.
- The CTs referred to in this section are CTs that are delivered with the CT-connected meter.

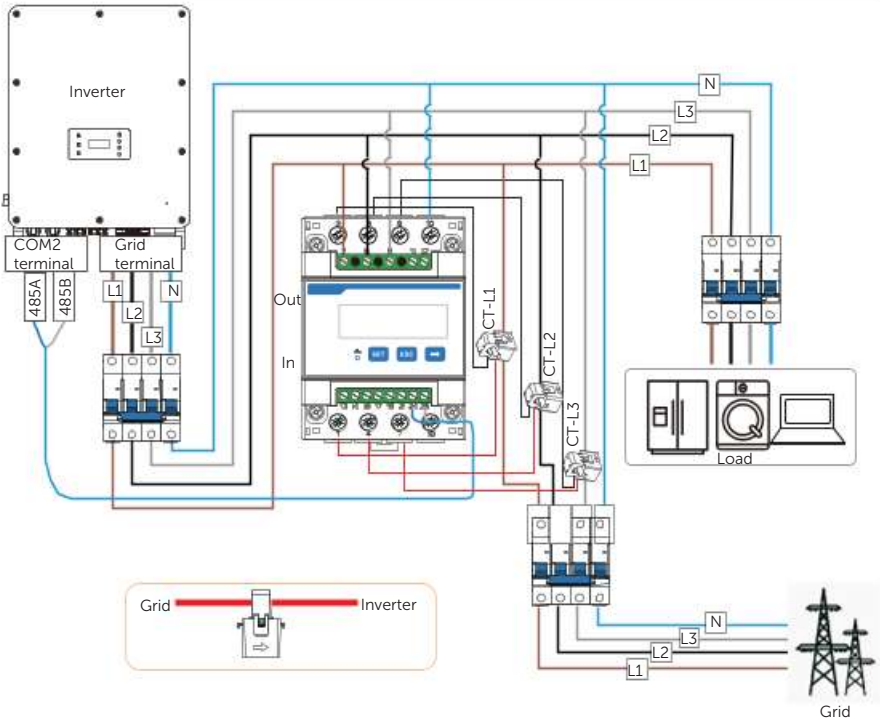

Figure 14-14 System wiring with CT-connected meter

NOTICE!

- Terminal 2, 5 and 8 of the meter must be connected to the grid side. Terminal 1, 4 and 7 must be connected to the S1 wire of the CTs, and terminal 3, 6 and 9 be connected to the S2 wire of the CTs. Otherwise, the system power data might be misread.
- The arrow on the CT must point at the inverter.
- Markings on the CTs might be R, S and T or L1, L2 and L3. Make sure to clip CT-R/CT-L1 to the L1 wire, CT-S/CT-L2 to the L2 wire, and CT-T/CT-L3 to the L3 wire.

Meter terminal definition

Table 14-3 Terminal definition of SolaX CT-connected meter

Terminal No.	Definition	Description
2, 5, 8	UA, UB, UC	Voltage input terminal of phase A, B and C respectively connected to L1 L2 and L3 wire
10	UN	Connected to the N wire
1, 4, 7	IA*, IB*, IC*	Current input terminal of the three phases, connected to the S1 wire of CT
3, 6, 9	IA, IB, IC	Current input terminal of the three phases, connected to the S2 wire of CT
24	RS485A	RS485 terminal A
25	RS485B	RS485 terminal B

Wiring procedure

- Step 1:** Strip around 10 mm wire insulation off the voltage cables, and then connect L1, L2 and L3 wires respectively to terminal 2, 5 and 8, and the N wire to terminal 10 of the meter.
- Step 2:** Clip the CTs onto the L1, L2 and L3 wires in the direction from grid to inverter.
- Step 3:** Connect the S1 wire of the three included CTs respectively to terminal 1, terminal 4 and terminal 7, and S2 wire of the CTs respectively to terminal 3, 6 and 9 of the meter.

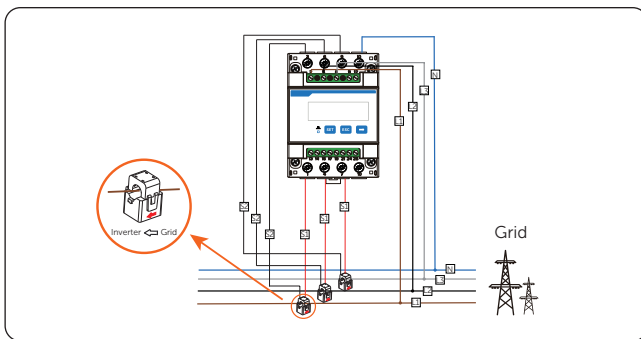

Figure 14-15 Connecting CT-connected meter to the grid

Step 4: Strip 15 mm wire insulation off the other end of the communication cable.

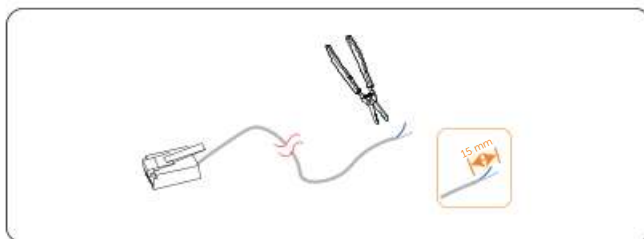

Figure 14-16 Stripping communication cable for meter

Step 5: Connect the conductors to terminal 24 and 25 of the meter.

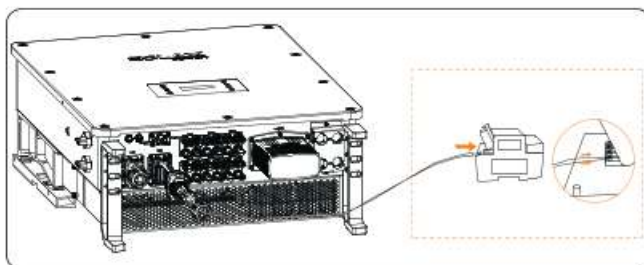

Figure 14-17 Connecting inverter to meter

Setting procedure

After connecting CT to the inverter, set parameters for them on the inverter.

Step 1: Select **Advance Settings > Meter/CT Setting**.

Step 2: Enable **Meter**, and then set **Meter1Addr** to **1** and **Meter1 Direction** to **Positive**.

You can check the connection status in **Meter/CT Check**. For details, see "[Setting Meter/CT Check](#)".

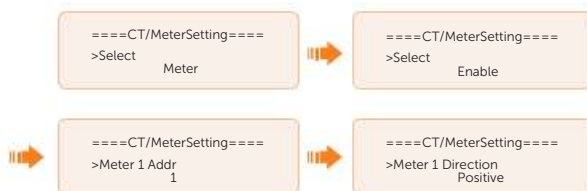

Figure 14-18 Setting meter for the inverter

14.4.4 Connection of Two Meters

If you have another power generation device (such as an inverter) at home and wants to monitor both device, our inverter provides a Meter 2 Communication function to monitor the other power generation device.

NOTICE!

- For connecting CT and meter, or connecting two meters, prepare an RJ45 splitter adapter and a proper waterproof enclosure for it in advance.
- The device for monitoring the system (device at Meter 1 position) can be CT, direct-connected meter and CT-connected meter, but the device for monitoring the other power generation device (device at Meter 2 position) can only be meters, either direct-connected meter or CT-connected meter. The following diagrams use the connection of CT and direct-connected meter for example.

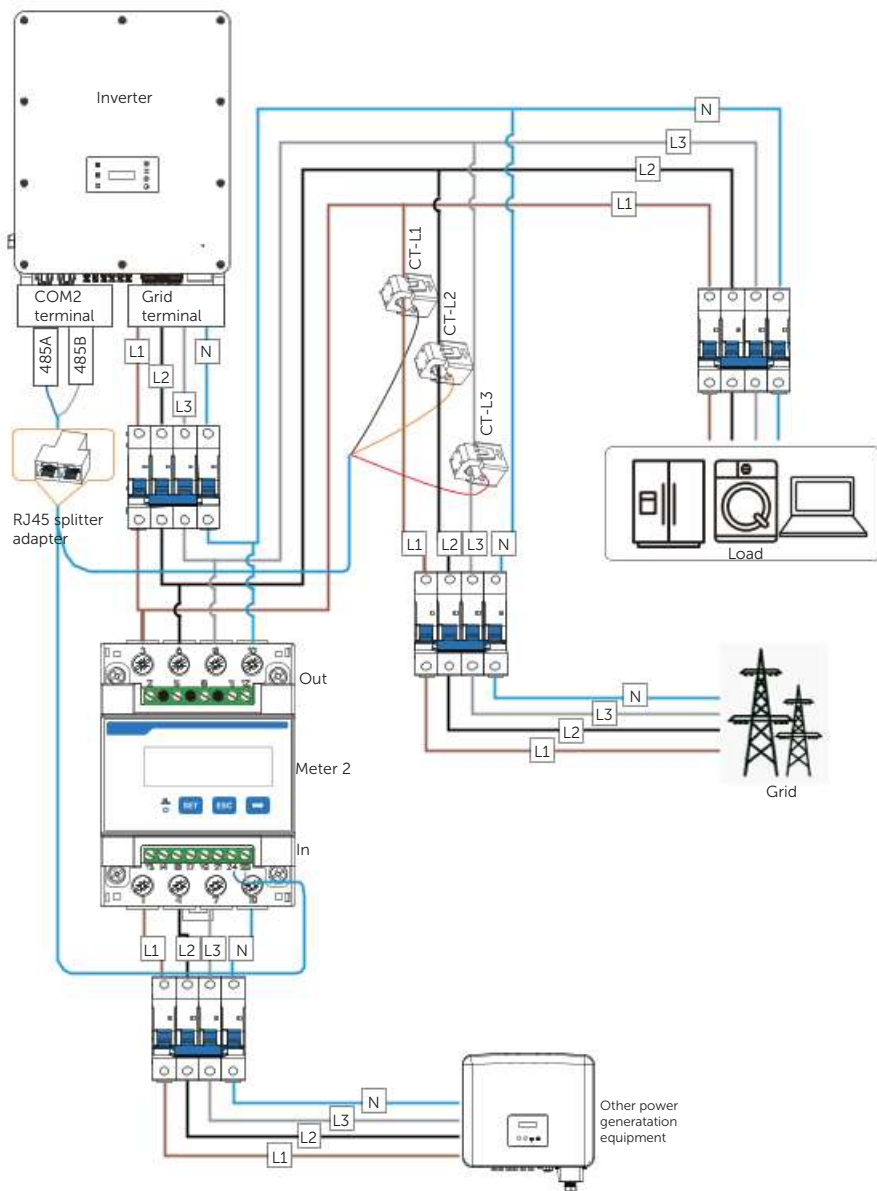

Figure 14-19 Connection diagram of CT and direct-connected meter

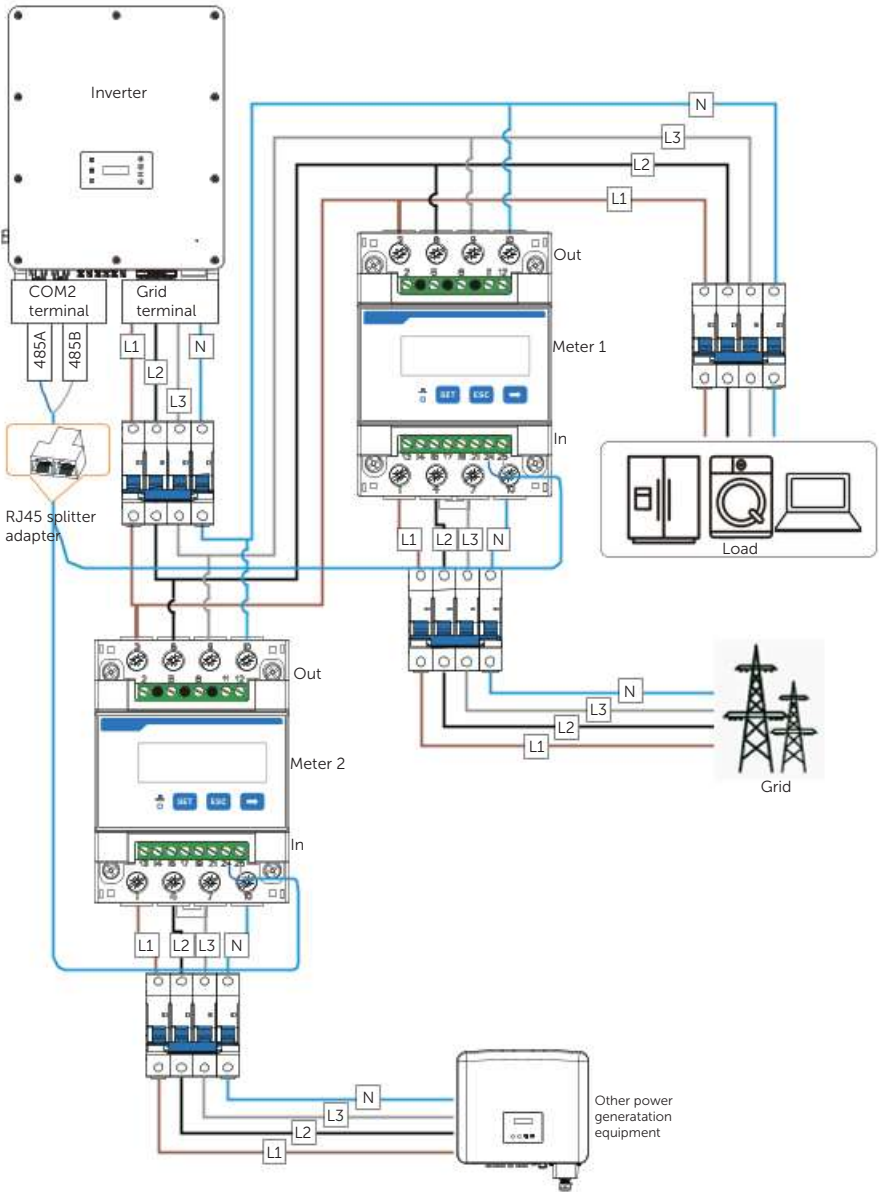

Figure 14-20 Connection diagram of two direct-connected meters

Wiring procedure

Step 1: Follow the above steps to connect the meter, CT and inverter.

Step 2: Connect the RJ45 terminals to the RJ45 splitter adapter.

Setting procedure

After connecting the CT and meter to the inverter, you need to set parameters on the inverter LCD before they can work normally for the system.

Step 1: Select **Advance Settings > Meter/CT Setting**.

Step 2: Set the Meter/CT:

- » Case 1: CT and Meter 2 are connected (CT for SolaX inverter, Meter 2 for another power generation device). CT is set by default. Check whether the address and direction of Meter2 are set based on actual connection.

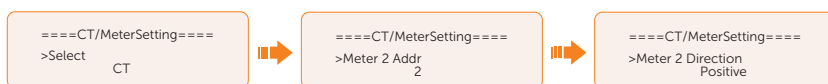

Figure 14-21 Selecting CT and set Meter2 data

- » Case 2: Meter 1 and Meter 2 are connected (Meter 1 for SolaX inverter, Meter 2 for another power generation device). Select **Meter** and enable the Meter function. Check whether the address and direction of Meter 1 and Meter 2 are set based on actual connection.

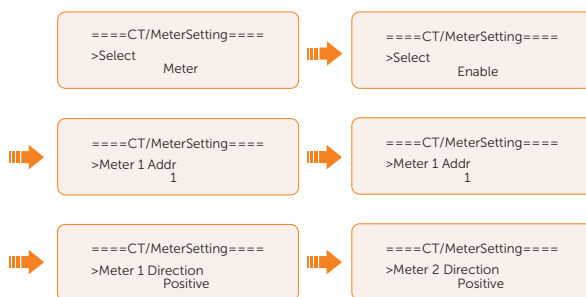

Figure 14-22 Selecting meter and set Meter 1 and Meter 2 data

Step 3: Set the CT type.



Figure 14-23 Setting the limits

Related operation

Setting Meter/CT Check

- **Installation Check:** It is for checking whether the Meter/CT has been correctly connected. It is vital to the normal function of the whole system. Therefore, we recommend performing installation check after connecting the Meter/CT.

Select **Meter/CT Setting > Meter/CT Check**, and then enable **Installation Check**.

The system will perform Meter/CT check immediately after you enable it, and then automatically restores to the disabled status after the check completes.

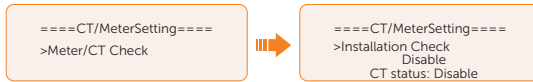

- **Cyclic Check:** It is for periodically checking whether the Meter/CT is in good condition when the inverter is running.

Select **Meter/CT Setting > Meter/CT Check**, and then enable **Cyclic Check**.

Once Cyclic Check is enabled, the system will check the Meter/CT status periodically based on the defined cycle.



Figure 14-24 Checking Meter/CT status

14.5 Capacity Expansion

DANGER!

- Before conducting cable connections, ensure that the system is powered off. Otherwise, electric shocks may occur.
- After the system powers off, there will still be the remaining electricity and heat which may cause electric shocks and body burns. Please wear personal protective equipment (PPE) and begin servicing the system 15 minutes after power off.
- Only qualified person can perform the maintenance for the device.

NOTICE!

- As for the battery capacity, up to **two cabinets** can be connected.

14.5.1 Capacity Expansion of Two AELIO-B200 Cabinets

NOTICE!

- The master cabinet that appeared in the chapter is an old one, as well as the slave cabinet is a new one.
- If the slave cabinet is an old one, please contact SolaX's after-sales personnel.

System wiring diagram

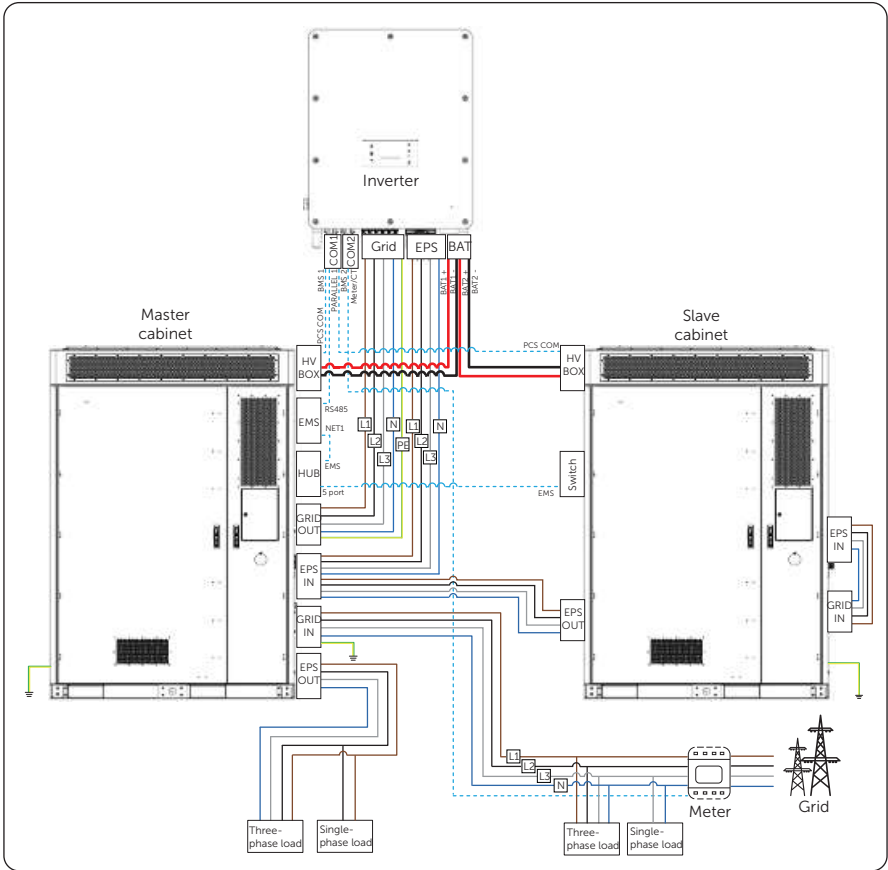

Figure 14-25 System wiring diagram

Cable making before conducting capacity expansion

Step 1: Power cables making on the high-voltage side.

Table 14-4 Information for making power cable

Power cable		Terminal	Heat-shrink tubing	
Cross-sectional area	Strip length		Diameter	Length
25 mm ² (3AWG)	15±1 mm	RNB38-8	Ø15 mm	40-50 mm

- » Take out terminals (part D2), heat-shrink tubing, and 25 mm² power cables;
- » Strip the cable jacket about 15±1 mm from the end, and cut a piece of heat-shrink tubing (Ø15 mm) 40-50 mm long;

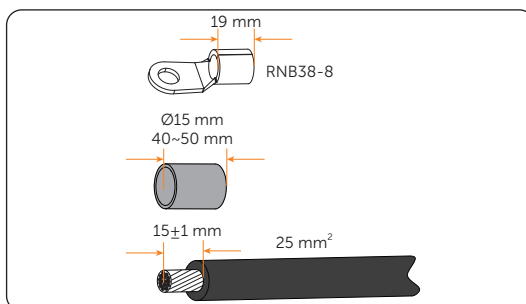

Figure 14-26 Stripping cable jacket

- » Carefully slide the heat-shrink tubing onto one end of the cable, and slip the wires all the way into the terminal;

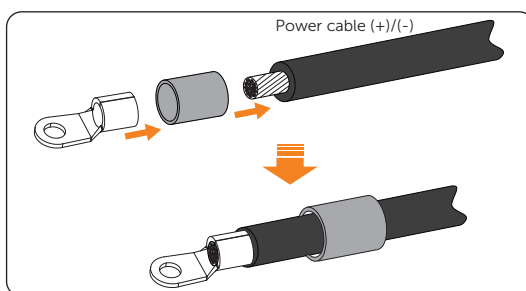

Figure 14-27 Assembling heat-shrink tubing, cable, and terminal

- » Crimp the terminal by using a hydraulic wire crimper, and heating the heat-shrink tubing.

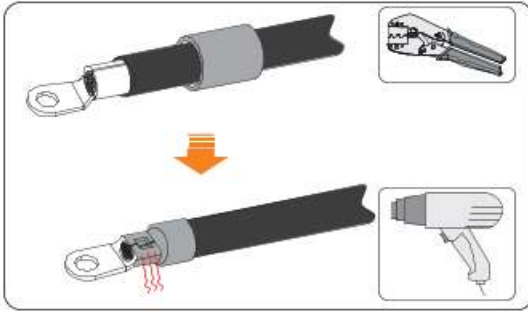

Figure 14-28 Crimping the terminal and heating the heat-shrink tubing

Step 2: Power cables making on the inverter side:

- » Disassemble the battery connectors (part E2 and part F2).

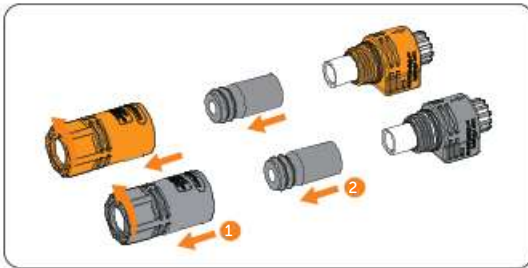

Figure 14-29 Disassembling battery connectors

- » Thread the battery power cable through the swivel nut and then the cable support sleeve. Strip 15 ± 1 mm insulation off.

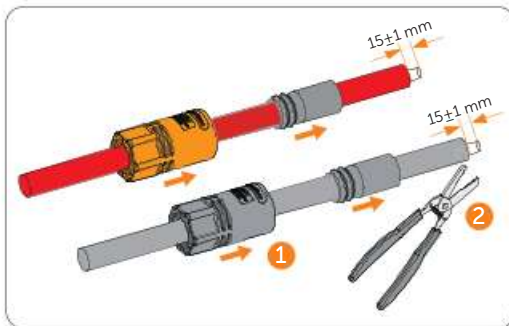

Figure 14-30 Stripping the battery power cable

- » Insert the stripped cable into the connector enclosure. Ensure that the stripped cable and the enclosure are of the same polarity. Crimp it with a hydraulic plier at 7.2 ± 0.2 mm and ensure that the exposed core of the cable is no more than 1 mm.

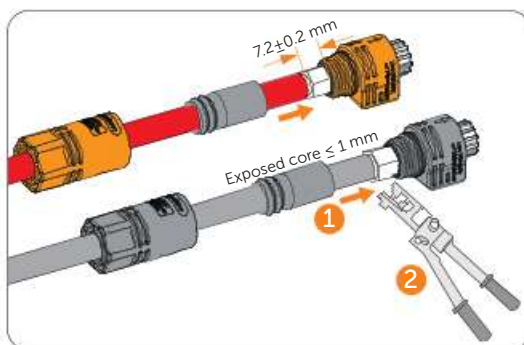

Figure 14-31 Crimping the terminal

NOTICE!

- Before the battery power cables are stripped, please ensure that the exposed core of cables should be less than 1 mm when the battery connectors are crimped.

- » Pull the cable support sleeve over the crimped battery connector enclosure and then the swivel nut to the enclosure. Tighten the swivel nut.

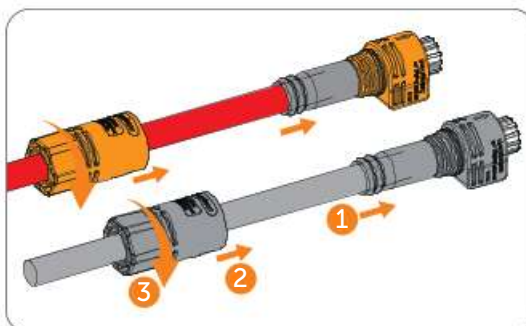

Figure 14-32 Tightening the battery connector

Cable connection between master cabinet and inverter

Step 1: Remove the covers of P- and P+ ports on the high-voltage box, unplug the power cables.

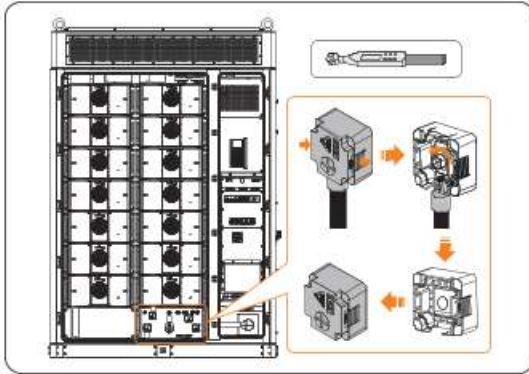

Figure 14-33 Removing power cables

WARNING!

- After removing the power cables, it is necessary to install the covers back, otherwise electric shock may occur.

Step 2: Unscrew M6 hexalobular screws to remove the large and small covers of cabinet 1.

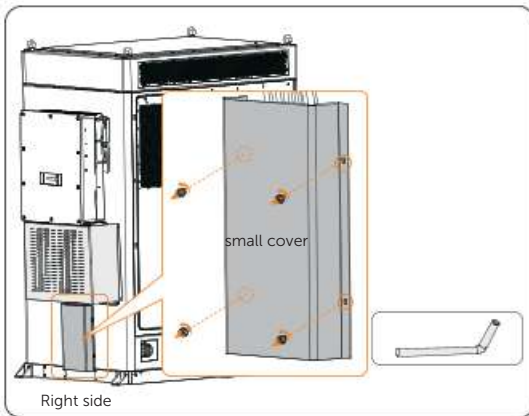

Figure 14-34 Removing small cover

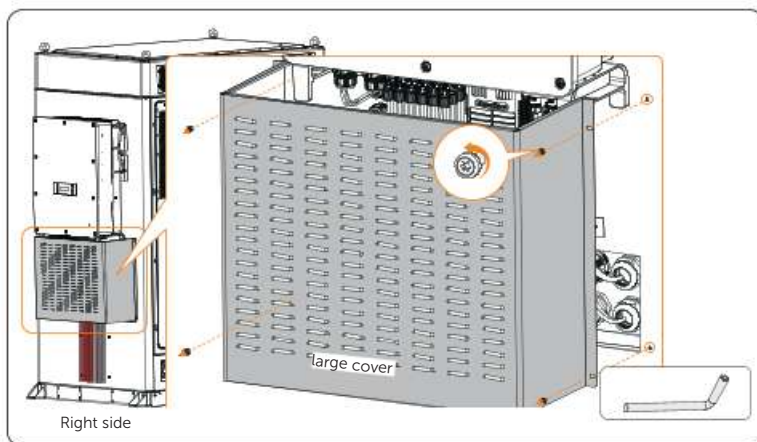

Figure 14-35 Removing large cover

NOTICE!

- If the master cabinet has been installed with the large and small covers, please comply with step 3. If not, please go to step 4.

Step 3: Turn the cable glands of BAT+ and BAT- ports counter-clockwise to remove power cables.

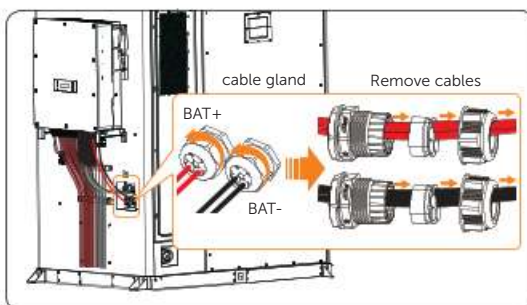

Figure 14-36 Turning cable gland counter-clockwise

Step 4: Pinch the tab on the sides of the battery connectors of the inverter and pull it at the same time to disassemble the battery connectors of the inverter.

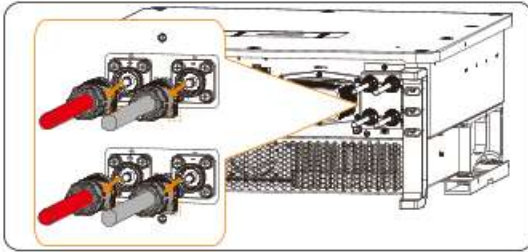

Figure 14-37 Removing the battery connectors

Step 5: Thread the positive power cable through the cable gland and cabinet to connect to the high-voltage box, as well as the negative power cable. Then insert the rubber stoppers to seal the cable entry holes.

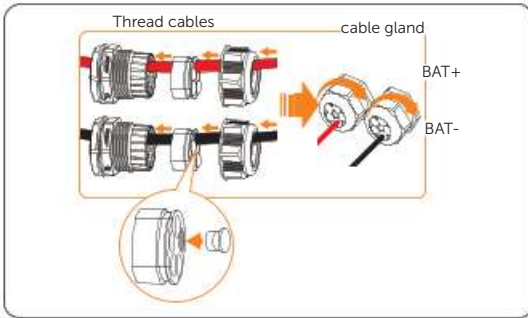

Figure 14-38 Threading power cable

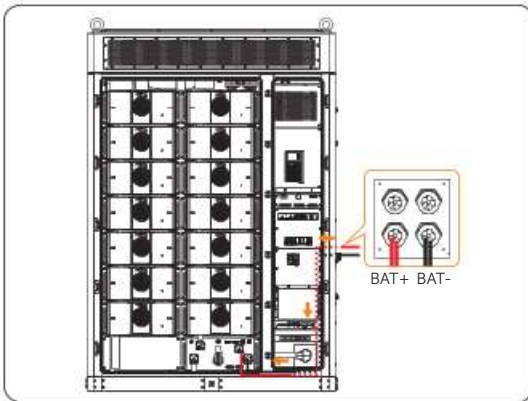

Figure 14-39 Threading direction

Step 6: Connect the battery connectors to BAT1+ and BAT1- of inverter until there is an audible "Click". Gently pull the cable backward to ensure firm connection.

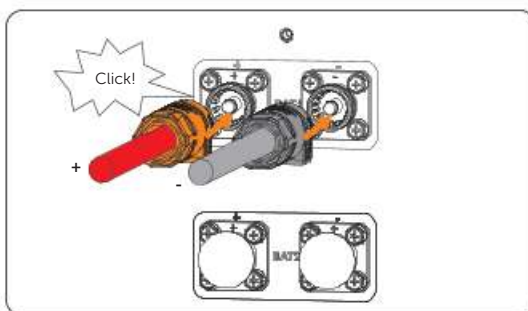

Figure 14-40 Connecting assembled battery cables

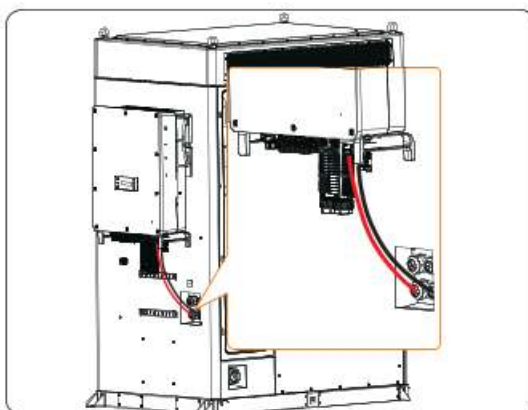

Figure 14-41 Well connected battery cables

Step 7: Insert and tighten M8 screws to connect power cables to the high-voltage box.

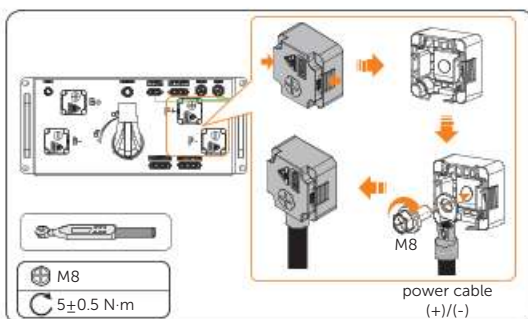

Figure 14-42 Connecting power cables

Cable connection between slave cabinet and inverter

- Step 1:** For power cables connection between slave cabinet and inverter, please refer to “Cable connection between slave cabinet and inverter” (skip Step 2 and Step 4), please insert the power cables into BAT2+ and BAT2- ports of the inverter.
- Step 2:** For communication between slave cabinet and inverter, please refer to “BMS communication connection”, please connect the PCS communication cable to the BMS 2 of the inverter.

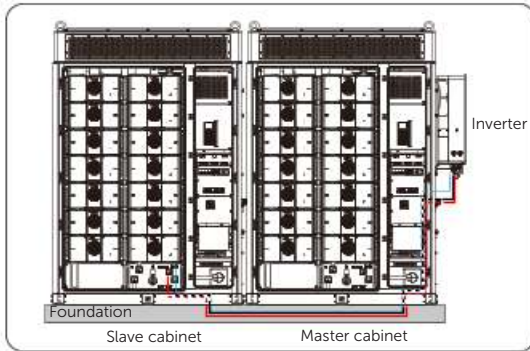

Figure 14-43 Threading cables

Cable connection between master cabinet and slave cabinet

- Step 1:** Connect **EPS IN** of the master cabinet and **EPS OUT** of the slave cabinet.
- » Prepare a four-core cable (Ø 6 mm²/10 AWG), make an EPS cable with RNB5-8 terminals (part C2) according to the table below (see “7.3 EPS Connection” steps 2 to 5);

Table 14-5 Relevant information for EPS cable

	Cable			Terminal	Heat-shrink tubing	
	Cable protective layer	Cross-sectional area	Strip length		Diameter	Length
4-core cable	Cable protective layer	/	100 mm	/	/	/
	L1/L2/L3/N	6 mm ² (10AWG)	8 mm	RNB5-8	Ø8 mm	20 mm

- » After opening the door of the slave cabinet, connect the cable to **EPS OUT**. For details, you can see “7.3 EPS Connection” steps 6 to 11.
- » Unscrew M4 screws to remove cover of the master cabinet, and then unscrew M8 screws;

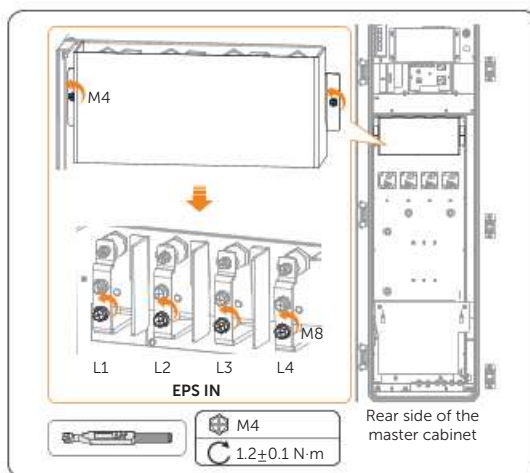

Figure 14-44 Loosening M4 and M8 screws

- » Thread it through the cable clamp and cable hole in the master cabinet, connect the other end to **EPS IN** of the master cabinet, and finally fully tighten M8 screws (torque: 12 ± 1 N·m);

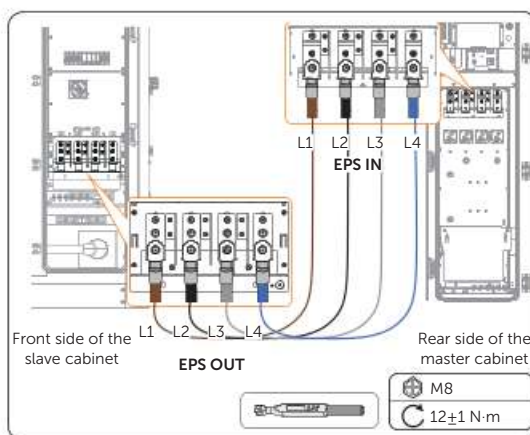

Figure 14-45 Connecting EPS cable

- » Tighten M5 and M6 screws (torque for M5: 3 ± 0.3 N·m; torque for M6: 5 ± 0.5 N·m) to fasten the cable clamp, and then fully tighten M5 butterfly nuts;
- » Reattach the cover and tighten M4 screws (torque: 1.2 ± 0.1 N·m);

Step 2: Disconnect the ethernet cable between port **EMS** of the switch and port **NET1** of the EMS 1000 in slave cabinet.

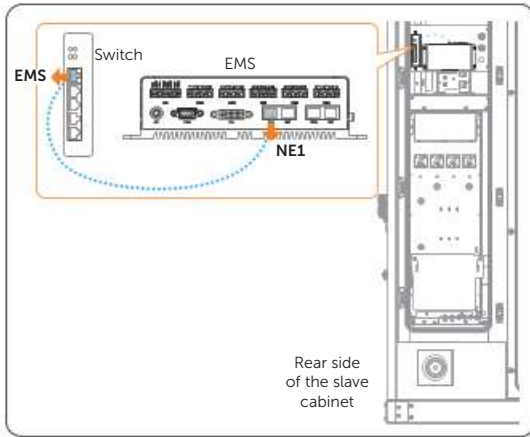

Figure 14-46 Disconnecting cable

Step 3: Connect the communication cable (part B2)

Step 4: Connect one end of communication cable (part B2) to the port **5** of the switch in the master cabinet, thread it through cable holes from the master cabinet to slave cabinet, and then connect the other end to port **EMS** of the switch in the slave cabinet.

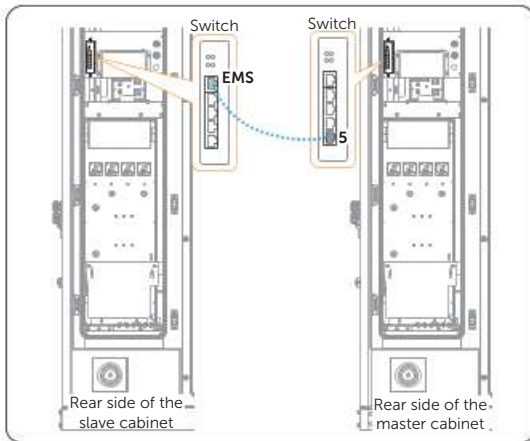

Figure 14-47 Connecting ethernet cable between switches

Step 5: Finally, lay the fireproof mud to plug the cable threading holes of both the master and slave cabinets. Additionally, you should prepare the fireproof mud.

Cable connection of slave cabinet

Step 1: After opening the back door of the slave cabinet, please unscrew M5 and M8 screws.

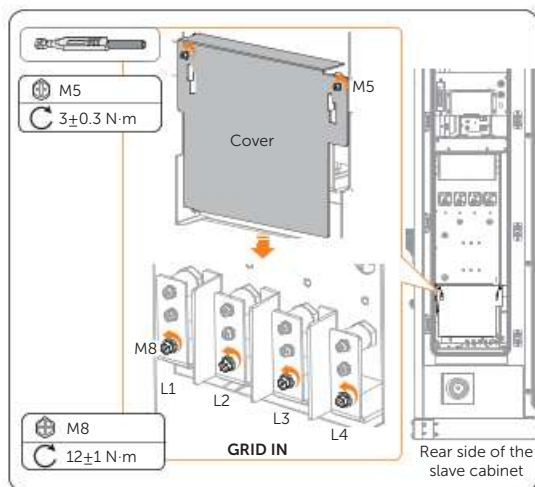

Figure 14-48 Loosening M4 and M8 screws

Step 2: Prepare a four-core cable ($\varnothing 6 \text{ mm}^2/10 \text{ AWG}$), and make a cable with RNB5-8 terminals (part C2) according to the table below (see "7.3 EPS Connection" steps 2 to 5).

Table 14-6 Relevant information for EPS cable

	Cable			Terminal	Heat-shrink tubing	
	Cable protective layer	Cross-sectional area	Strip length		Diameter	Length
4-core cable	Cable protective layer	/	100 mm	/	/	/
	L1/L2/L3/N	6 mm^2	8 mm	RNB5-8	$\varnothing 8 \text{ mm}$	20 mm

Step 3: Unscrew M4 screws to remove cover at **EPS IN**, and then unscrew M8 screws.

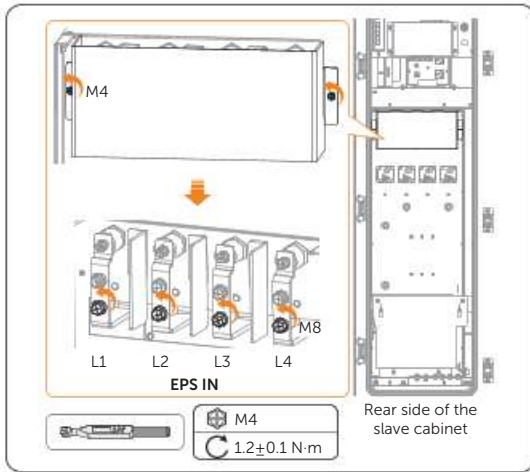

Figure 14-49 Loosening M4 and M8 screws at **EPS IN**

Step 4: Connect **EPS IN** and **GRID IN** of the slave cabinet, and then fully tighten M8 screws (torque: 12 ± 1 N·m)

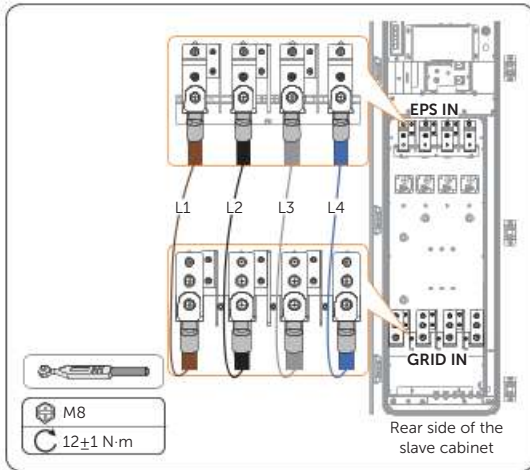

Figure 14-50 Connecting cable

Step 5: Reattach the covers at **EPS IN** and **GRID IN**, respectively, and fully tighten M4 screws (torque: 1.2 ± 0.1 N·m) and M5 screws (torque: 3 ± 0.3 N·m).

14.5.2 Capacity Expansion of AELIO-B200 Cabinet and AELIO-B100 Cabinet

NOTICE!

- The master cabinet that appeared in the chapter is an old one, as well as the slave cabinet is a new one.
- If the slave cabinet is an old one, please contact SolaX's after-sales personnel.

System wiring diagram

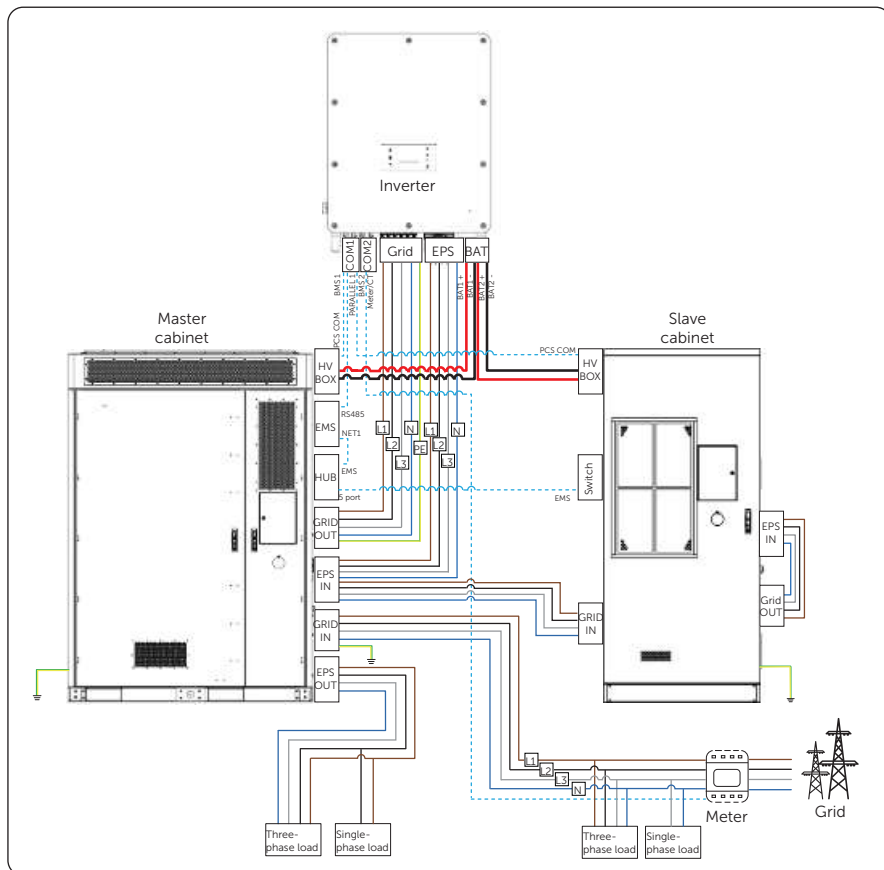

Cable making before conducting capacity expansion

Before conducting capacity expansion, you should make positive and negative power cables with RNB38-8 terminals (part D2) and battery connectors (Parts E2 and F2). For details, you can see "Cable making before conducting capacity expansion".

Cable connection between AELIO-B200 cabinet and inverter

For cable connection between AELIO-B200 cabinet and inverter, you can see "Cable connection between master cabinet and inverter".

Cable connection between AELIO-B100 cabinet and inverter

Step 1: Remove the covers of P- and P+ ports on the high-voltage box, unplug the power cables.

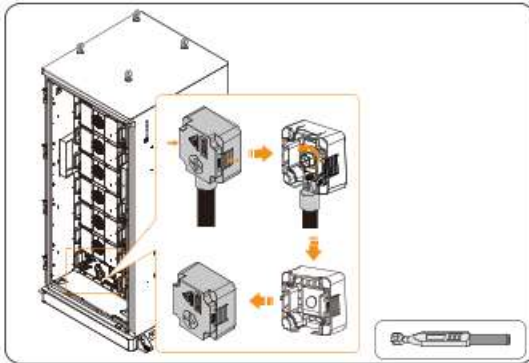

Figure 14-51 Removing power cables

Step 2: Turn the cable glands of BAT+ and BAT- ports counter-clockwise to remove power cables.

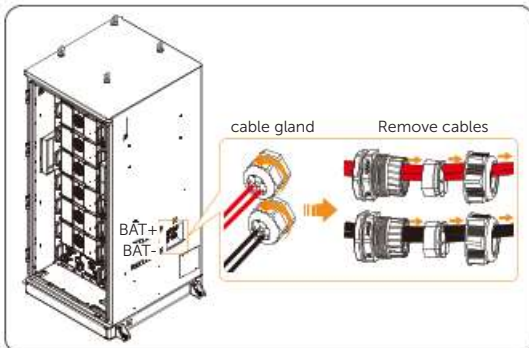

Figure 14-52 Turning cable gland counter-clockwise

Step 3: Insert and tighten M8 screws to connect power cables to the high-voltage box.

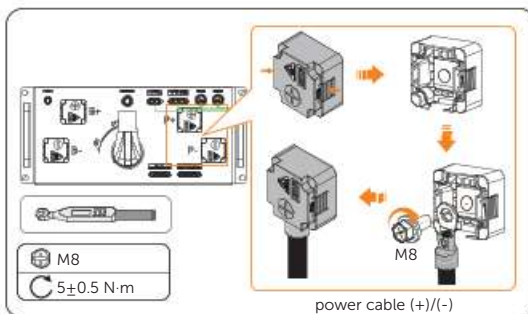

Figure 14-53 Connecting power cables

Step 4: Unscrew M4 screws to remove the cover of the slave cabinet and then thread the cable from the master cabinet to the slave cabinet.

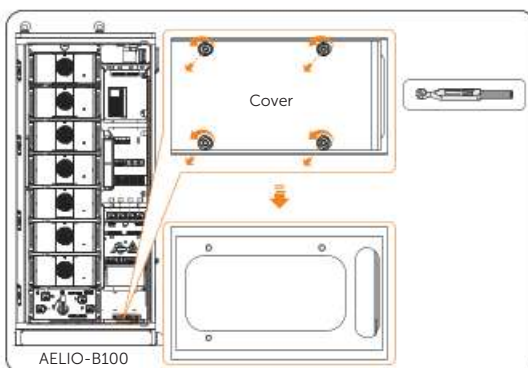

Figure 14-54 Unscrewing M4 screws and removing cover

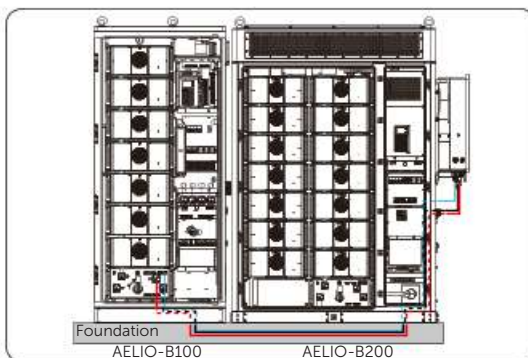

Figure 14-55 Threading cables

Step 5: Connect the battery connectors to BAT2+ and BAT2- of inverter until there is an audible "Click". Gently pull the cable backward to ensure firm connection.

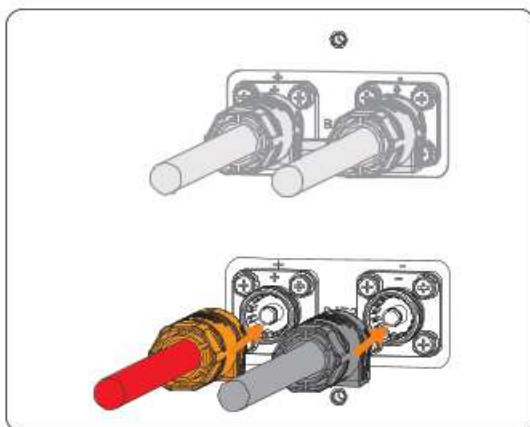

Figure 14-56 Connecting assembled battery cables

Cable connection between AELIO-B200 Cabinet and AELIO-B100 Cabinet

Step 1: Connect one end of the cable to **EPS IN** of AELIO-B200.

- » Prepare a four-core cable ($\varnothing 6 \text{ mm}^2/10 \text{ AWG}$), make an EPS cable with RNB5-8 terminals (part C2) according to the table below (see "7.3 EPS Connection" steps 2 to 5);

Table 14-7 Relevant information for making cable

	Cable		Terminal	Heat-shrink tubing	
	Cable protective layer	Cross-sectional area		Diameter	Length
4-core cable	/	/	/	/	/
	L1/L2/L3/N	6 mm^2	8 mm	RNB5-8	$\varnothing 8 \text{ mm}$

- » After opening the door of AELIO-B100, unscrew M4 screws to remove cover of the master cabinet, and then unscrew M8 screws;

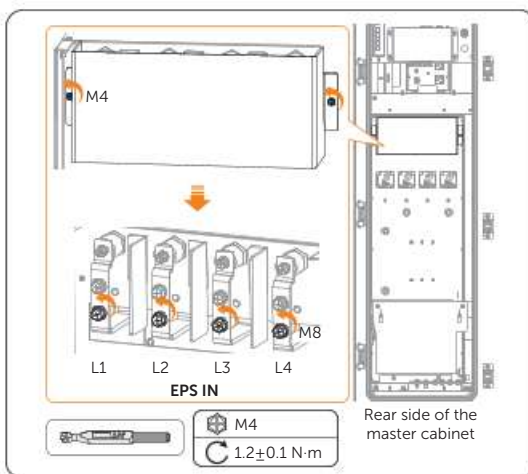

Figure 14-57 Loosening M4 and M8 screws

- » Thread it through the cable clamp and cable hole, connect one end to **EPS IN** of AELIO-B200, and finally fully tighten M8 screws (torque: $12 \pm 1 \text{ N}\cdot\text{m}$).

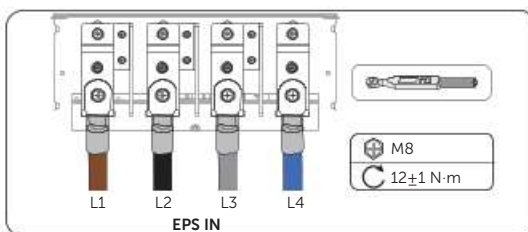

Figure 14-58 Connecting cable to **EPS IN**

Step 2: Connect the other end of the cable to **GRID IN** of AELIO-B100.

- » Unscrew M6 screws to open the cable clamp, and keep the screws, washers, and nut properly;

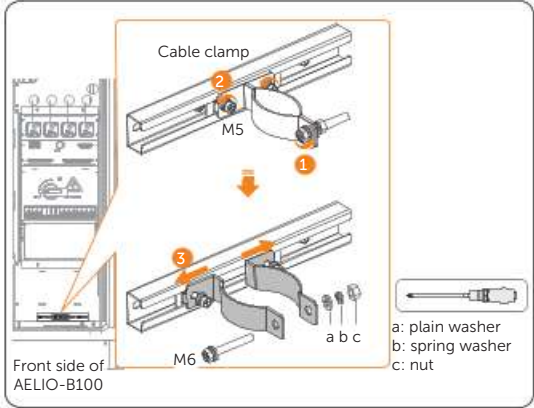

Figure 14-59 Unscrewing M6 screw

- » Thread the cable through the "yellow area" from outside to inside;

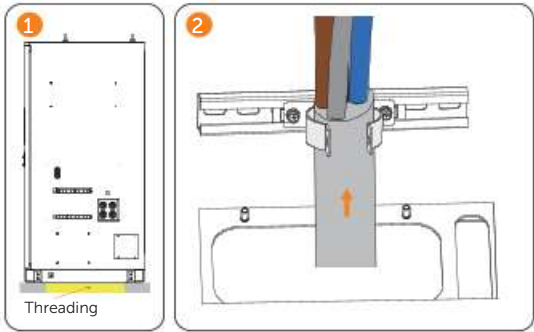

Figure 14-60 Threading cable

- » Unscrew M4 screws to remove the cover, loosen M8 screws on the bar (it is recommended to loosen the bottom screw), connect the cable, tighten M8 screws (torque: 12 ± 1 N·m), and then reattach the cover and fully tighten M4 screws (torque: 1.6 ± 0.2 N·m).

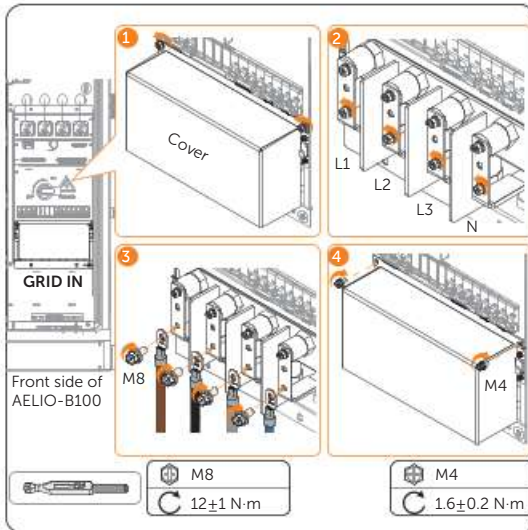

Figure 14-61 Connecting cable

- » Tighten M5 and M6 screws (torque for M5: 3 ± 0.3 N·m; torque for M6: 5 ± 0.5 N·m) to fasten the cable clamp, and then fully tighten M5 butterfly nuts.
- » Finally, after connecting the cable, it would show as following figure.

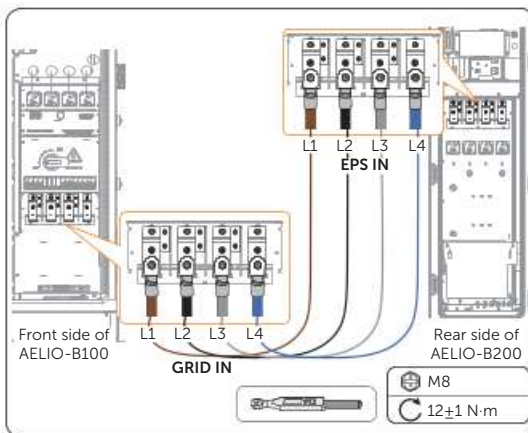

Figure 14-62 Wiring diagram

Step 3: Disconnect the ethernet cable between port **EMS** of the switch and port **NET1** of the EMS 1000 in AELIO-B100.

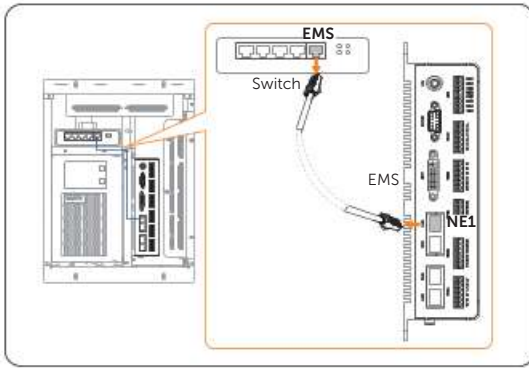

Figure 14-63 Disconnecting cable

Step 4: Connect the communication cable between AELIO-B200 and AELIO-B100.

- » Connect one end of communication cable (part B2) to the port **5** of the switch in AELIO-B200;
- » Thread it through cable holes from AELIO-B200 to AELIO-B100;
- » Open the cover of the slotted type cable trunking in AELIO-B100 to thread the cable, and then reattach the cover;

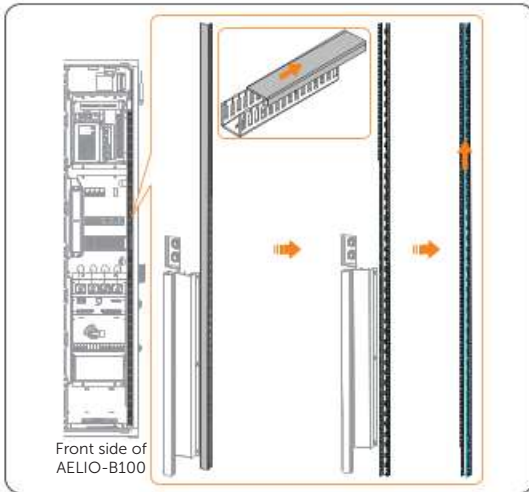

Figure 14-64 Threading communication cable

- » Connect the other end to port **EMS** of the switch in AELIO-B100.

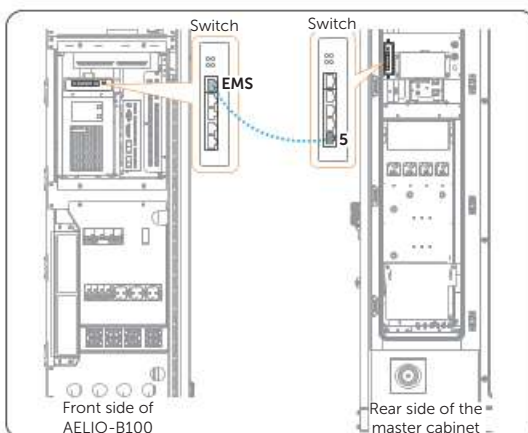

Figure 14-65 Connecting ethernet cable between switches

Step 5: Finally, lay the fireproof mud to plug the cable threading holes of both the master and slave cabinets. Additionally, you should prepare the fireproof mud.

Cable connection of AELIO-B100

Step 1: Connect EPS wires and GRID wires together with M6 screws (torque: 5 ± 0.5 N·m).

Table 14-8 Guide to cable wiring

EPS wire to GRID wires			
L1 → L1	L2 → L2	L3 → L3	N → N

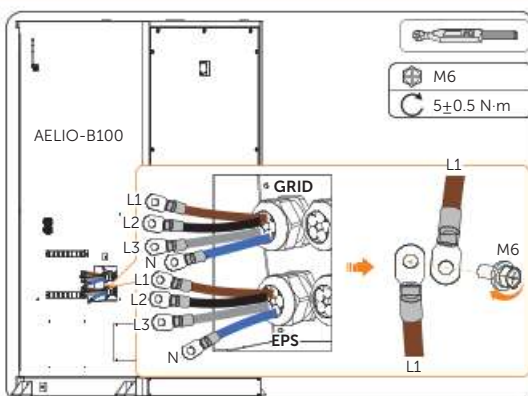

Figure 14-66 Connecting wires

⚠ DANGER!

- You must take measures to protect the electrical wires from water damage.

14.5.3 Pairing device after capacity expansion

After finishing wiring, the added device should be paired via EMS.

Step 1: Gently and correctly guide the key into the keyhole, and then turn it clockwise to unlock the screen door.

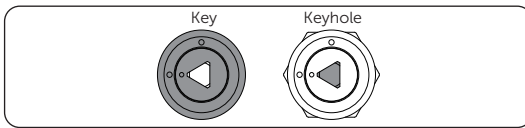

Figure 14-67 Correct position

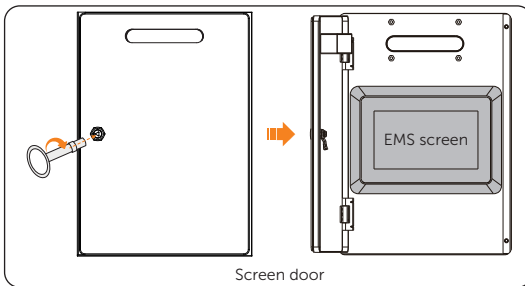

Figure 14-68 Unlocking screen door

Step 2: Sign in an admin account from the login page.

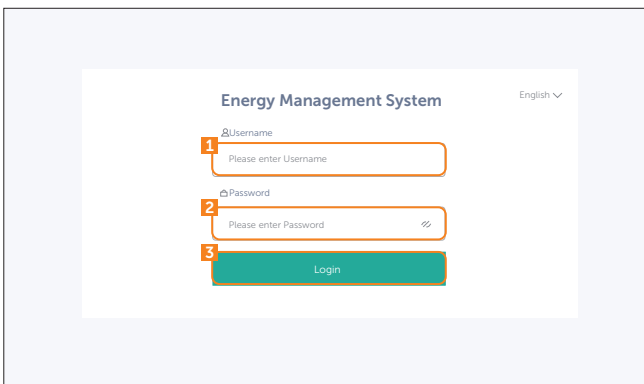

Figure 14-69 Signing in an admin account



SolaX Power Network Technology (Zhejiang) Co., Ltd.

Add.: No. 278, Shizhu Road, Chengnan Sub-district, Tonglu County,
Hangzhou, Zhejiang, China
E-mail: info@solaxpower.com