



X3-HYB-G4 PRO

4 kW / 5 kW / 6 kW / 8 kW / 10 kW / 12 kW / 15 kW

User Manual

Version 6.0

www.solaxpower.com



2018/04/18 in the last code of at
www.solaxpower.com

STATEMENT

Copyright

Copyright © SolaX Power Network Technology (Zhejiang) Co., Ltd. All rights reserved.

No part of this manual may be reproduced, transmitted, transcribed, stored in a retrieval system, or translated into any language or computer language, in any form or by any means without the prior written permission of SolaX Power Network Technology (Zhejiang) Co., Ltd.

Trademarks



SOLA X and other symbol or design (brand name, logo) that distinguishes the products or services offered by SolaX has been trademark protected. Any unauthorized use of the above stated trademark may infringe the trademark right.

Notice

Please note that certain products, features, and services mentioned in this document may not be within the scope of your purchase or usage. Unless otherwise specified in the contract, the contents, information, and recommendations presented in this document are provided "as is" by SolaX. We do not provide any warranties, guarantees, or representations, whether express or implied.

The content of the documents is reviewed and updated as needed. However, occasional discrepancies may occur. SolaX retains the right to make improvements or changes in the product(s) and the program(s) described in this manual at any time without prior notice.

The images included in this document are solely for illustrative purposes and may differ based on the specific product models.

For more detailed information, kindly visit the website of SolaX Power Network Technology (Zhejiang) Co., Ltd. at www.solaxpower.com.

SolaX retains all rights for the final explanation.

About This Manual

Scope of Validity

This manual is an integral part of X3-HYB G4 PRO series inverter. It describes the transportation, storage, installation, electrical connection, commissioning, maintenance and troubleshooting of the product. Please read it carefully before operating.

This manual is valid for the following inverter models:

- X3-HYB-4.0-P
- X3-HYB-5.0-P
- X3-HYB-6.0-P
- X3-HYB-8.0-P
- X3-HYB-10.0-P
- X3-HYB-10.0K-P
- X3-HYB-12.0-P
- X3-HYB-15.0-P

Model description



Item	Meaning	Description
1	Product family name	"X3-HYB": Three-phase energy storage series inverter that supports grid connection of photovoltaic system.
2	Power	"4.0": rated output power of 4 kW. Note that "10.0K" is specially designed for Belgium users.
3	Professional	X3-HYB G4 PRO series inverter is an upgrade from X3-Hybrid G4 series inverter.

Target Group



The installation, maintenance and grid-related setting can only be

performed by qualified personnel who:

- Are licensed and/or satisfy state and local regulations.
- Have good knowledge of this manual and other related documents.

Conventions

The symbols that may be found in this manual are defined as follows.

Symbol	Description
 DANGER	Indicates a hazardous situation which, if not avoided, will result in death or serious injury.
 WARNING	Indicates a hazardous situation which, if not avoided, could result in death or serious injury.
 CAUTION!	Indicates a hazardous situation which, if not avoided, could result in minor or moderate injury.
NOTICE!	Provides tips for the optimal operation of the product.

Change History

Version 6.0 (2025-11-14)

- Added arc settings and SoC balance to ["10.7.2 Advanced Settings"](#).
- Modified ["14 Technical Data"](#) (only inverters above 12 kW support fan).
- Updated ["9.3 DC Switch"](#).
- Updated ["5.4 Additionally Required Materials"](#)(added recommended specifications for breaker and cable).
- Deleted content about ripple control.
- Modified "solax485, adap box, and datahub" into neutral words.
- Updated QR code for user manual.
- Updated ["6.2 Scope of Delivery"](#) (added changeover switch and added note to dustproof cover) and updated ["2.5.2 Application Schemes"](#) (added changeover switch for Australia).

Version 5.0 (2025-04-22)

- Updated ["15.4 Application of Datahub"](#) (Modified into 10 the max. number of inverters connecting to a datahub).
- Added exemption clause to chapters 1 and 4.
- Corrected a setting field in manual mode.

- Deleted positioning cardboard and PV disassembly tool from packing list and updated ["7 Mechanical Installation"](#).
- Changed the series inverter name from "X3-HYB-G4 PRO" into "X3-HYB G4 PRO".
- Modified the contact information of America and warranty.

Version 4.0 (2025-01-06)

- Added the file import and export function to ["12.3.2 Upgrading Firmware"](#).
- Added content related to adapter box G1 to ["10.7.1 User Settings"](#) and ["15.2 Application of Adapter Box"](#).
- Updated ["8.6 COM 1 Communication Connection"](#) and ["8.7 COM 2 Communication Connection"](#) (Added content about dustproof cover) and updated ["6.2 Scope of Delivery"](#) (Added an accessory part: communication connector).

Version 3.0 (2024-11-22)

- Updated ["8.6 COM 1 Communication Connection"](#) and ["8.7 COM 2 Communication Connection"](#) (removed dustproof cover) and updated ["6.2 Scope of Delivery"](#) (removed communication connector).
- Updated ["12.3.2 Upgrading Firmware"](#).

Version 2.0 (2024-09-19)

- Updated ["8.6 COM 1 Communication Connection"](#) and ["8.7 COM 2 Communication Connection"](#) (Added content about dustproof cover) and updated ["6.2 Scope of Delivery"](#) (Added an accessory part: communication connector).
- Updated ["2.5.1 Circuit Diagram"](#), ["2.5.2 Application Schemes"](#), and ["15.7 CT/Meter Connection Scenarios"](#).
- Updated ["14 Technical Data"](#) (Added Belgium model, pollution degree, and active anti-islanding method).
- Updated ["9 System Commissioning"](#) (Added description on self check).
- Updated ["Setting Safety Code"](#) in ["10.7.2 Advanced Settings"](#) (Added safety code of Hungary).
- Updated ["6.2 Scope of Delivery"](#) (Added content about Dongle pocket Wi-Fi+4G and added communication connector).
- Updated ["2.7.5 TOU Mode"](#) (Added the setting of maximum charging power to charge mode).
- Deleted the detailed pin definition on terminals COM1 and COM2 and added pin assignment for ["8.6.2 RS485 Communication Connection"](#), ["8.7.4 DRM Connection"](#) and ["8.6.3 BMS Communication Connection"](#).

- Updated “2.6 Work Status” (Added a work state: Fault & Charging).
number of inverters without matebox in parallel system).
- Updated “15.6 Application of Parallel Function” (Changed the largest
- Updated “Contact Information” (Modified contact information about Australia service).

Version 1.0 (2024-08-13)

- Updated “7 Mechanical Installation” (Added steps for installing wire shielding cover).
- Updated “6.2 Scope of Delivery” (Added shielding cover parts and marked CT as optional).

Version 0.0 (2024-06-20)

Initial release

Table of Contents

1	Safety	1
1.1	General Safety	1
1.2	Safety Instructions of PV, Inverter and Grid	2
1.2.1	Safety Instructions of PV	2
1.2.2	Safety Instructions of Inverter	2
1.2.3	Safety Instructions of Utility Grid	3
2	Product Overview	4
2.1	Product Introduction	4
2.2	Appearance	4
2.3	Supported Power Grid	5
2.4	Symbols on the Label and Inverter	6
2.5	Working Principle	7
2.5.1	Circuit Diagram	7
2.5.2	Application Schemes	8
2.6	Work Status	12
2.7	Work Mode	14
2.7.1	Self use Mode (Priority: Loads>Battery>Grid)	14
2.7.2	Feed-in Priority (Priority: Loads>Grid)	16
2.7.3	Backup Mode (Priority: Loads>Battery>Grid)	17
2.7.4	Peak Shaving Mode	19
2.7.5	TOU Mode	20
2.7.6	EPS Mode (Priority: Loads>Battery)	21
2.7.7	Manual Mode	22
2.7.8	Export Control	22
3	System Overview	23
4	Transportation and Storage	26
5	Preparation before Installation	27
5.1	Selection of Installation Location	27
5.1.1	Environment Requirement	27
5.2	Installation Carrier Requirement	29
5.2.1	Clearance Requirement	29
5.3	Tools Requirement	31
5.4	Additionally Required Materials	32

- 6 Unpacking and Inspection 34**
 - 6.1 Unpacking.....34
 - 6.2 Scope of Delivery.....35
- 7 Mechanical Installation 38**
 - 7.1 Dimensions for mounting.....39
 - 7.2 Installation procedures.....39
- 8 Electrical Connection 45**
 - 8.1 Overview of Electrical Connection45
 - 8.1.1 Terminals and Parts of Inverter45
 - 8.1.2 Cable Connections of Inverter.....47
 - 8.2 PE Connection49
 - 8.3 AC Connection.....51
 - 8.4 PV Connection58
 - 8.5 Battery Power Cable Connection.....62
 - 8.6 COM 1 Communication Connection66
 - 8.6.1 Meter/CT Connection.....67
 - 8.6.2 RS485 Communication Connection71
 - 8.6.3 BMS Communication Connection73
 - 8.6.4 Parallel Connection75
 - 8.7 COM 2 Communication Connection.....76
 - 8.7.1 Datahub, heatpump, and EVC communication connection77
 - 8.7.2 DI/DO Communication Connection81
 - 8.7.3 V2X Connection83
 - 8.7.4 DRM Connection84
 - 8.8 Monitoring Connection88
- 9 System Commissioning 91**
 - 9.1 Checking before Power-on91
 - 9.2 Powering on the System.....91
 - 9.3 DC Switch92
- 10 Operation on LCD..... 95**
 - 10.1 Introduction of Control Panel.....95
 - 10.2 Introduction of Menu Interface97
 - 10.3 System ON/OFF.....100
 - 10.4 Mode Select100
 - 10.5 System Status100
 - 10.6 History Data.....102
 - 10.7 Settings104

10.7.1	User Settings.....	104
10.7.2	Advanced Settings.....	111
10.8	About.....	132
11	Operations on SolaXCloud App and Webpage.....	133
11.1	Introduction of SolaXCloud.....	133
11.2	Operation Guide on SolaXCloud App.....	133
11.2.1	Downloading and Installing App.....	133
11.2.2	Operation on the App.....	134
11.3	Operations on SolaXCloud Webpage.....	134
12	Troubleshooting and Maintenance.....	135
12.1	Power off.....	135
12.2	Troubleshooting.....	135
12.3	Maintenance.....	144
12.3.1	Maintenance Routines.....	144
12.3.2	Upgrading Firmware.....	146
13	Decommissioning.....	149
13.1	Disassembling the Inverter.....	149
13.2	Packing the Inverter.....	152
13.3	Disposing of the Inverter.....	152
14	Technical Data.....	153
15	Appendix.....	159
15.1	Application of Generator.....	159
15.1.1	Introduction of Generator Application.....	159
15.1.2	Notice for Generator Application.....	159
15.1.3	ATS Control Mode.....	159
15.1.4	Dry Contact Mode.....	161
15.2	Application of Adapter box.....	164
15.2.1	Introduction of Adapter box Application.....	164
15.2.2	Wiring Connection Diagram.....	164
15.2.3	Communication Connection with Inverter.....	165
15.2.4	Settings for Adapter box G2.....	166
15.3	Application of EV-Charger.....	167
15.3.1	Introduction of EV-Charger Application.....	167
15.3.2	Wiring Connection Diagram.....	167
15.3.3	Charging Modes.....	168
15.3.4	Communication Connection with Inverter.....	168
15.3.5	Settings for EV-Charger.....	169

15.4 Application of Datahub	170
15.4.1 Introduction of Datahub Application	170
15.4.2 Wiring Connection Diagram.....	170
15.4.3 Communication Connection with Inverter.....	171
15.4.4 Settings for Datahub.....	172
15.5 Application of Micro-grid	173
15.5.1 Introduction of Micro-grid Application.....	173
15.5.2 Wiring Connection Diagram.....	173
15.5.3 Working Modes.....	174
15.5.4 Cable Connection (Hybrid inverter).....	175
15.5.5 Cable Connection (On-grid inverter).....	176
15.5.6 Cable Connection (Meter).....	176
15.6 Application of Parallel Function	178
15.6.1 Introduction of Parallel Application.....	178
15.6.2 Notice for Parallel Application.....	178
15.6.3 System Wiring Diagram	179
15.6.4 System Wiring Procedure.....	180
15.6.5 Settings for Parallel Connection.....	184
15.7 CT/Meter Connection Scenarios	186
15.7.1 Connection of CT.....	186
15.7.2 Connection of Direct-connected Meter	189
15.7.3 Connection of CT-connected Meter	192
15.7.4 Connection of Two Meters	195

1 Safety

1.1 General Safety

The series inverter has been meticulously designed and tested to comply with the relevant state and international safety standards. Nevertheless, like all electrical and electronic equipment, safety precautions must be observed and followed during the installation of the inverter to minimize the risk of personal injury and ensure a safe installation.

Please carefully read and comprehend, and strictly adhere to the comprehensive instructions provided in the user manual and any other relevant regulations prior to the installation of the inverter. The safety instructions in this document serve as supplementary guidelines to local laws and regulations.

SolaX shall not be liable for any consequences resulting from the violation of the storage, transportation, installation, and operation regulations outlined in this document. Such consequences include, but are not limited to:

- Inverter damage caused by force majeure events, such as earthquakes, floods, thunderstorms, lightning, fire hazards, volcanic eruptions, and similar events.
- Inverter damage due to human causes.
- Inverter damage caused by strong vibrations from external factors before, during and after installation.
- Usage or operation of the inverter in violation of local policies or regulations.
- Failure to comply with the operation instructions and safety precautions provided with the product and in this document.
- Improper installation or usage of the inverter in unsuitable environmental or electrical conditions.
- Unauthorized modifications to the product or software.
- Inverter damage occurring during transportation by the customer.
- Storage conditions that do not meet the requirements specified in this document.
- Installation and commissioning performed by unauthorized personnel who lack the necessary licenses or do not comply with state and local regulations.

1.2 Safety Instructions of PV, Inverter and Grid

Save these important safety instructions. Failure to follow these safety instructions may result in damage to the inverter and injury or even loss of life.

1.2.1 Safety Instructions of PV

DANGER!

Potential risk of lethal electric shock associated with the photovoltaic (PV) system

- Exposure to sunlight can result in the generation of high DC voltage by PV modules, which can lead to electric shock causing severe injuries or even death.
- Never touch the positive or negative poles of the PV connecting device, and avoid touching both poles simultaneously.
- Do not ground the positive or negative poles of the PV modules.
- Only qualified personnel can perform the wiring of the PV modules.

WARNING!

- Overvoltage protection with surge arresters should be provided when the PV system is installed. The inverter is fitted with SPDs on both PV input side and MAINS side.
- Please consult professionals before installing SPDs.

WARNING!

- Make sure that the input DC voltage does not exceed the maximum DC input voltage specified for the inverter. Overvoltage can cause irreversible damage to the inverter, and such damage is not covered by the warranty.
- PV modules should have an IEC61730 class A rating.

1.2.2 Safety Instructions of Inverter

DANGER!

Potential risk of lethal electric shock associated with the inverter

- Only operate the inverter if it is in a technically faultless condition. Operating a faulty inverter may lead to electric shock or fire.
- Do not attempt to open the enclosure without authorization from SolaX. Unauthorized opening of the enclosure will void the warranty and can result in lethal danger or serious injury due to electric shock.
- Make sure that the inverter is reliably grounded before any operation to prevent the risk of electric shock causing lethal danger or serious injury.
- Only qualified personnel can perform the installation, wiring, maintenance of the inverter by following this document and the related regulations.

 **WARNING!**

- During operation, avoid touching any parts of the inverter other than the DC switch and LCD panel (if any).
- Never connect or disconnect the AC and DC connector while the inverter is running.
- Prior to conducting any maintenance, turn off the AC and DC power and disconnect them from the inverter. Wait for 5 minutes to fully discharge the energy.

 **WARNING!****Potential danger of scalding due to the hot enclosure of the inverter**

Avoid touching the inverter while it is running, as it becomes hot during operation and may cause personal injuries.

 **WARNING!**

When handling the battery, carefully follow all safety instructions provided in the battery manual. The battery used with the inverter must meet the specified requirements of the series inverter.

 **WARNING!**

Use insulated tools when installing the device, and always wear personal protective equipment during installation and maintenance.

 **CAUTION!**

- Make sure that children are supervised to prevent them from playing with the inverter.
- Pay attention to the weight of the inverter and handle it properly to avoid personal injuries.

NOTICE!

- The inverter has an integrated Type-B Residential Current Monitoring Unit (RCMU). If an external Residual Current Device (RCD) is required by local regulations, verify the type of RCD required. It is recommended to use a Type-A RCD with a rating of 300 mA. When required by local regulations, a Type-B RCD is also permitted.
- Keep all product labels and the nameplate on the inverter clearly visible and well-maintained.

1.2.3 Safety Instructions of Utility Grid

NOTICE!

Only connect the inverter to the grid with the permission of the local utility grid company.

2 Product Overview

2.1 Product Introduction

The X3-HYB G4 PRO series is an energy storage PV grid-connected inverter. It supports various intelligent solutions such as load management, wireless metering, dual battery terminals, and micro-grids, to achieve efficient and economical energy utilization. The X3-HYB G4 PRO series inverter can be used with SolaX batteries in different models.

2.2 Appearance

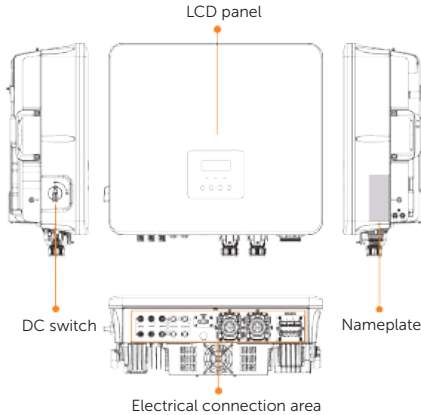

Figure 2-1 Appearance

Table 2-1 Description of appearance

Item	Description
Nameplate	Nameplate clearly shows the device type, serial number, DC / AC parameters, certification, etc.
LCD panel	Including screen, indicators and keys. The screen displays the device running information. The indicators show the status of inverter. The keys are used to set parameters.
DC switch	Disconnect the DC input when necessary.
Electrical connection area	Including MPPT terminals, battery terminals, Grid & EPS terminal, communication terminals, etc.

2.3 Supported Power Grid

There are different ways of wiring for different grid systems. TT / TN-S / TN-C-S are shown as below:

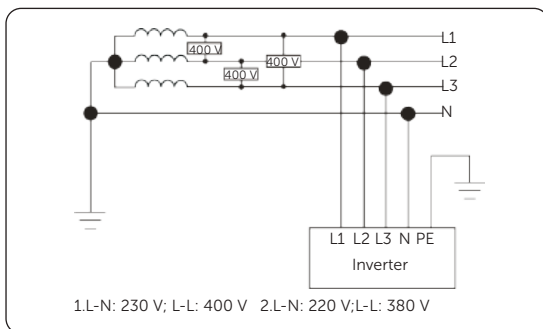

Figure 2-2 Supported power grid: TT

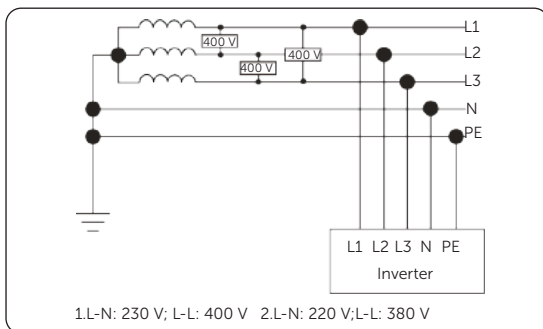

Figure 2-3 Supported power grid: TN-S

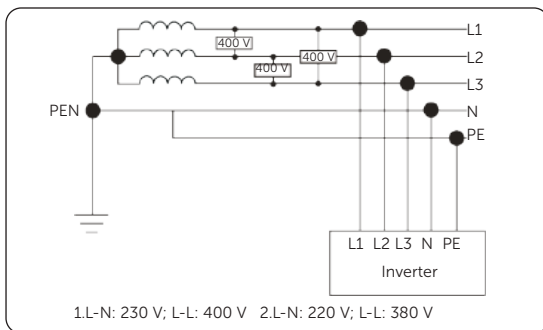













Figure 2-4 Supported power grid: TN-C-S

2.4 Symbols on the Label and Inverter

Table 2-2 Description of symbols

Symbol	Description
	CE mark. The inverter complies with the requirements of the applicable CE guidelines.
	TUV certified.
	RCM mark. The inverter complies with the requirements of the applicable RCM guidelines.
	Additional grounding point.
	Beware of hot surface. Do not touch a running inverter, as the inverter becomes hot during operation!
	Risk of electric shock. High voltage exists after the inverter is powered on!
	Risk of danger. Potential hazards exist after the inverter is powered on!
	Read the enclosed documentations.
	Do not dispose of the inverter together with household waste.
	Do not operate this inverter until it is isolated from battery, mains and on-site PV generation source.
 	Danger of high voltage. Do not touch live parts until you have disconnected the inverter from the power sources for 5 minutes.

2.5 Working Principle

2.5.1 Circuit Diagram

The inverter is equipped with multi-channel MPPT for DC input to ensure maximum power even under different photovoltaic input conditions. The inverter unit converts direct current into alternating current that meets the requirements of the power grid and feeds it into the power grid. The working principle of inverter is shown below:

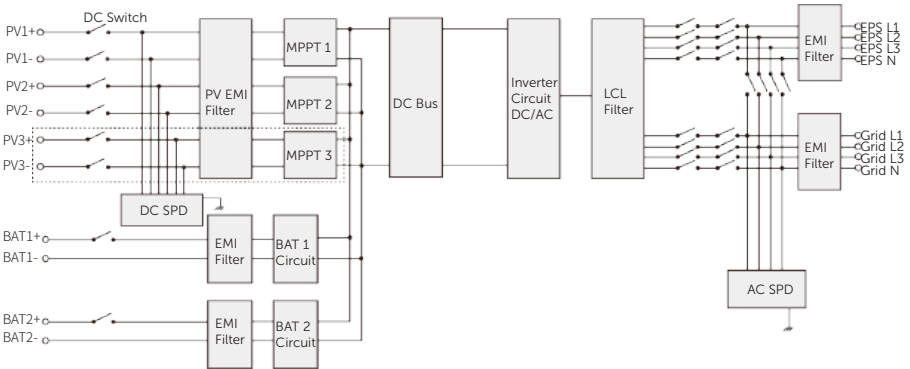

Figure 2-5 Circuit diagram of X3-HYB G4 PRO series inverter

NOTICE!

PV 3 in the dotted box is only available to 8 kW, 10 kW, 12 kW and 15 kW inverters.

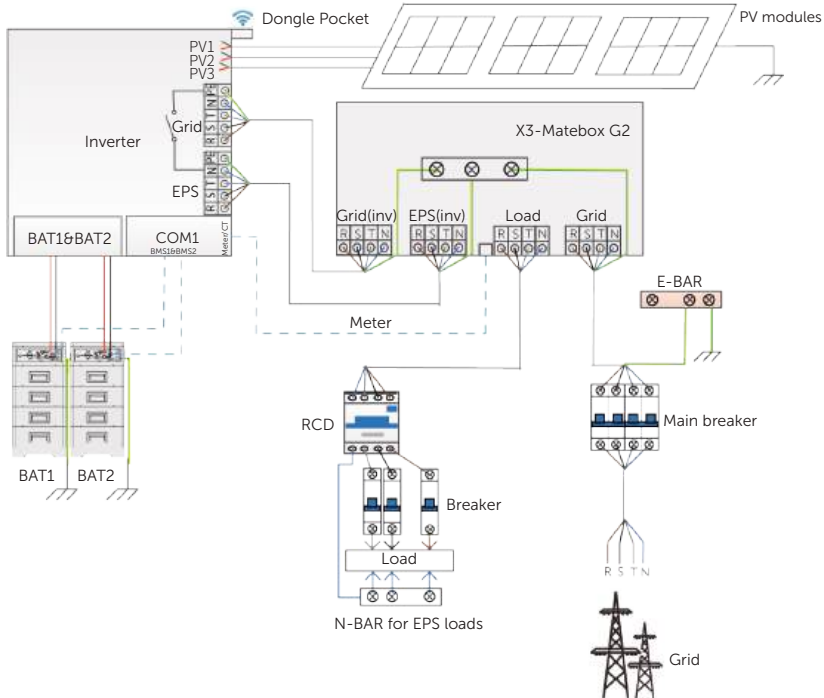

Figure 2-7 Whole home backup for Europe

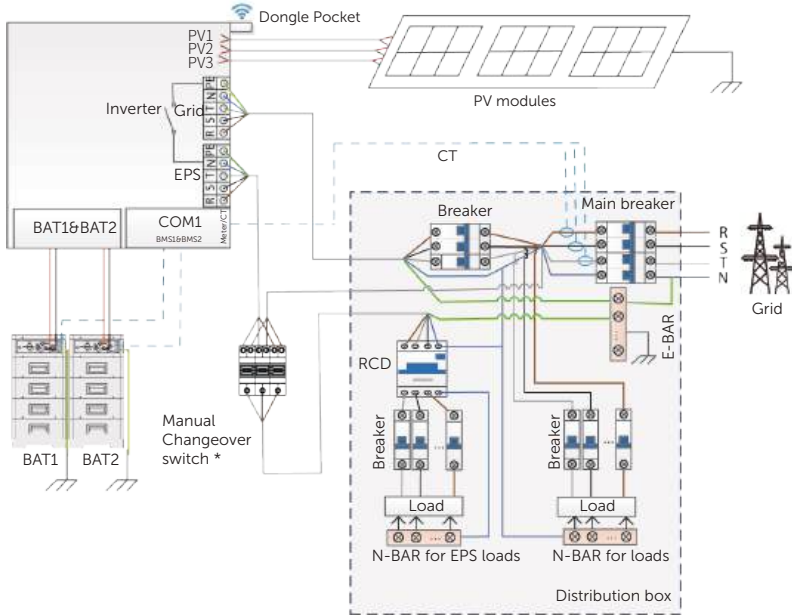

Figure 2-8 Partial home backup for Australia

* Included in the scope of delivery. When it is switched to "LOAD", the EPS loads gain power from the PV and battery. When the inverter is failed or under maintenance, switch it to "GRID" manually, to ensure that the EPS loads can work normally.

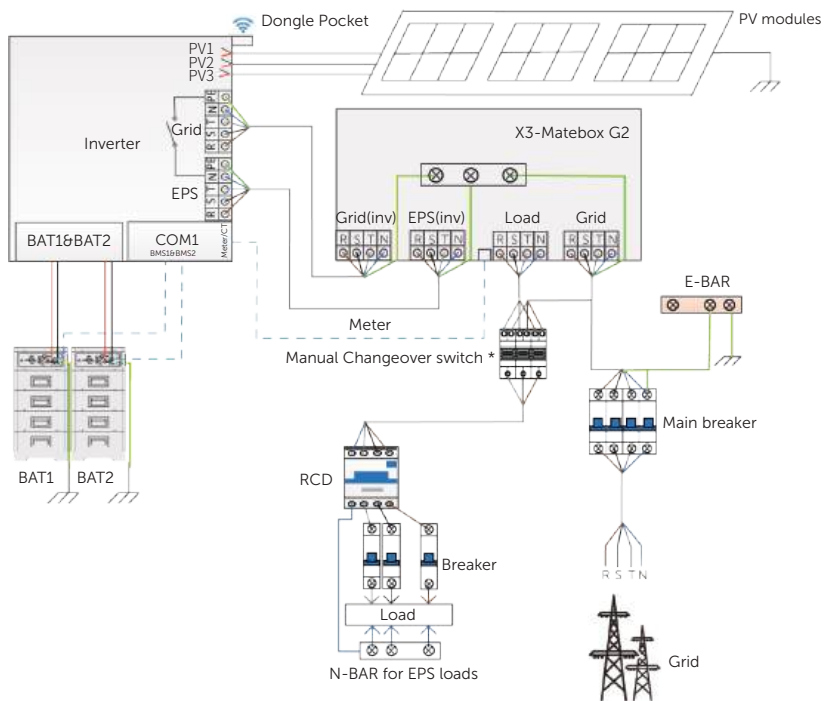

Figure 2-9 Whole home backup for Australia

* Included in the scope of delivery. When it is switched to "LOAD", the EPS loads gain power from the PV and battery. When the inverter is failed or under maintenance, switch it to "GRID" manually, to ensure that the EPS loads can work normally.

2.6 Work Status

The series inverter has 10 states: Waiting, Checking, Normal, EPS Checking, EPS, Fault, Idle, Standby, Abnormal Hibernate and Fault & Charging.

Table 2-3 Description of working state

State	Description
Waiting	<p>The inverter is waiting for the conditions to be met in order to enter Checking state. The conditions are:</p> <ul style="list-style-type: none"> the PV input voltage reaches the target value. the AC-side voltage and frequency meet the regulations of the grid.
Checking	The inverter is checking for conditions to enter Normal state.
Normal	<p>The inverter is working normally. The Normal state includes 3 situations: Normal (On-grid), Normal (R), and Normal (G).</p> <ul style="list-style-type: none"> Normal (On-grid): The inverter is connected to the public grid and works normally. Normal (R): The on-grid inverter is controlled by an external device. Normal (G): After the inverter disconnected from the public grid, a generator is started to ensure that the inverter works normally.
EPS Checking	The inverter is checking for conditions to enter EPS state.
EPS	The inverter is in off-grid state.
Fault	The inverter detects an error and reports the error code.
Idle	<p>An inverter goes into idle state in the following conditions:</p> <ul style="list-style-type: none"> the battery SOC reaches the minimum value; and the battery hibernates for there is no sufficient PV input voltage.
Standby	<p>An inverter goes into standby state in either of the two situations:</p> <ul style="list-style-type: none"> when the power of load is extremely low and there is no sufficient PV input voltage, or when the battery SOC is larger than or equal to 10% and there is no sufficient PV input voltage. <p>In this state, the inverter will constantly detect PV connection, load power and others, to determine whether to exit from the Standby state and enter the Normal state again.</p>
Abnormal Hibernate	The battery SOC is lower than the minimum value set before and the inverter detected a fault.

State	Description
Fault & Charging	When the voltage or frequency of the public grid is abnormal, the PV still charges batteries.

NOTICE!

When a device is in idle state, you can wake up the device by setting the following through the device LCD or SolaXCloud App:

- Re-set the working mode.
- Re-set the minimum battery SOC. It should be noted that: "the actual battery SOC — the re-set minimum battery SOC \geq 2%".
- Re-set the charging period.

2.7 Work Mode

When an inverter is in on-grid state, there are 6 working modes for you to select: Self use, Feed-in priority, Backup, Peak shaving, TOU, and Manual. You can choose one of them according to your lifestyle and environment.

When the power supply from the electric power company is cut off due to a power outage, the inverter will automatically switch to the EPS mode and connect to the distribution board for specific loads, thereby providing power to important loads.

For details about working mode setting, please refer to “10.7.1 User Settings”.

2.7.1 Self use Mode (Priority: Loads>Battery>Grid)

The self use mode is suitable for areas with low feed-in subsidies but high electricity prices. The power from PV supplies the loads first. After that, if there is surplus power, charge the battery first and then feed into the grid.

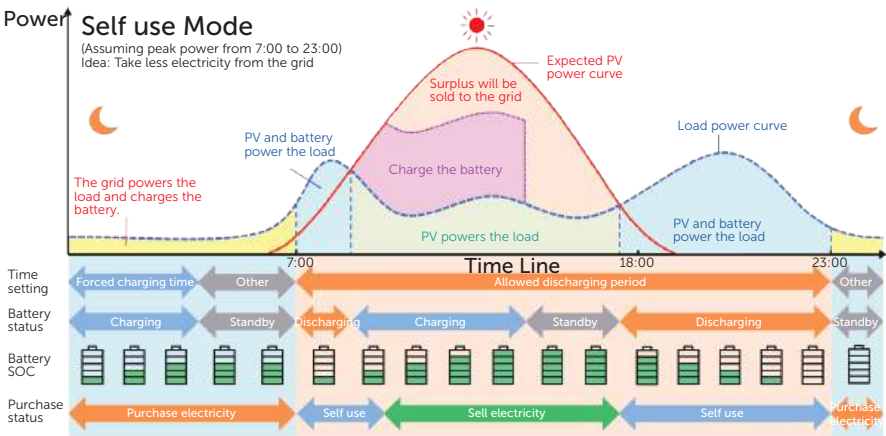

Figure 2-10 Self use mode

Table 2-4 Description of self use mode

Time period	Inverter working status
Forced charging period	Charge the battery first until the battery SOC reaches the specified value for Charge battery to . You can set whether the inverter draws power from the grid or not.

Time period	Inverter working status
Allowed discharging period	PV is sufficient (PV → load → battery → grid) <ul style="list-style-type: none"> The power generated from PV is supplied to the load first. After that, the remaining power is used to charge the battery. If there is still surplus electricity, it can be sold to the grid. It should be noted that, if the local utility restricts the sale of electricity to the grid, the Export Control value can be set for the inverter. Please refer to "Setting Export Control".
	PV is insufficient (PV+battery → load) <ul style="list-style-type: none"> The battery discharges, to supply power to the load. Once the remaining power reaches the Min SOC, the battery automatically stops discharging.

Note:

Charge battery to: The battery SOC charged from grid. 30% by default, the settable range is 10%~100%.

Min SOC: Minimum SOC of the battery under grid connection. 10% by default, the settable range is 10%~100%.

Export Control: The power exported to the grid. 300000 W by default, the settable range is from 0 to the rated output power.

Charge & Discharge Period

You can set two working periods: forced charging period and allowed discharging period. The other time except the charging & discharging period is defined as "other time periods".

- Forced charging period (Default period: 00:00~00:00, closed by default)

In the forced charging period, the inverter will charge the battery first until the battery SOC reaches the specified **Charge battery to** value set in each working mode. You can enable/disable the function of the inverter drawing power from the grid.

- Allowed discharging period (Default period: 00:00~23:59)

In the allowed discharging period, the inverter will allow the battery to discharge according to the working mode and load conditions.

- Other time periods

In other periods, the inverter can charge the battery but the battery cannot discharge power to others.

NOTICE!

The charge & discharge period is only applicable to self use mode, feed-in priority and backup mode. The priority of forced charging period is higher than all working modes.

2.7.2 Feed-in Priority (Priority: Loads>Grid)

The feed-in priority mode is suitable for areas with high feed-in subsidies. The power generated from PV is supplied to the loads first. If there is power left, sell the remaining power to the grid.

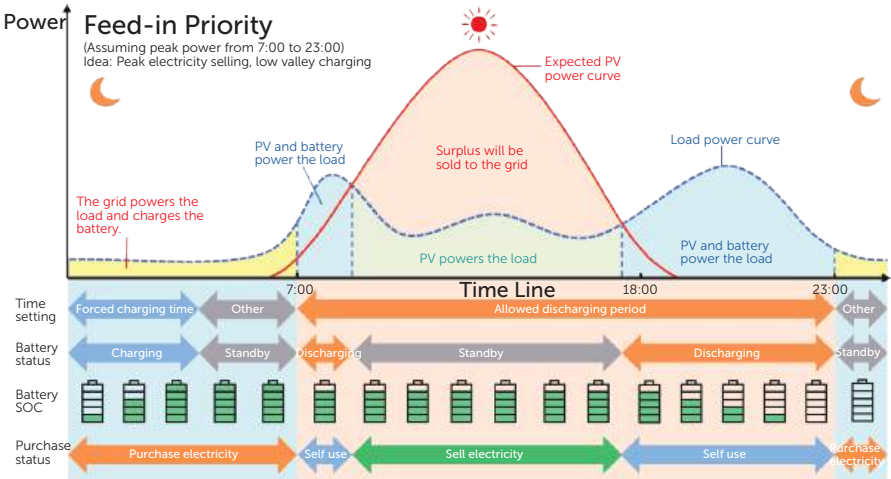

Figure 2-11 Feed-in priority

Table 2-5 Description of feed-in priority

Time period	Inverter working status
Forced charging period	<ul style="list-style-type: none"> Charge the battery first until the battery SOC reaches the specified value for Charge battery to. You can set whether the inverter draws power from the grid or not.
Allowed discharging period	<p>PV is sufficient (PV → load → grid)</p> <ul style="list-style-type: none"> The power generated from PV is directly supplied to the loads first. Any excess power beyond the load requirements will be fed into the grid. <p>PV is insufficient (PV+battery → load)</p> <ul style="list-style-type: none"> The PV and battery supply power to the loads at the same time. Once the remaining power reaches the Min SOC, the battery automatically stops discharging.

Note:

Charge battery to: The battery SOC charged from grid. 50% by default, the setttable range is 10%~100%.

Min SOC: Minimum SOC of the battery under grid connection. 10% by default, the setttable

range is 10%~100%.

NOTICE!

- You can set two working periods: forced charging period and allowed discharging period. Please refer to “Charge & Discharge Period” for details.
- In feed-in priority mode, consider whether the battery can be charged during the daytime. If not, it is recommended to set forced charging period during off-peak hours.

2.7.3 Backup Mode (Priority: Loads>Battery>Grid)

The backup mode is suitable for areas with frequent power outages.

In this mode, the battery power amount is maintained at a relatively high level, to ensure that the emergency loads can be used when the inverter disconnects from the grid. Its working logic is same with that of the self use mode.

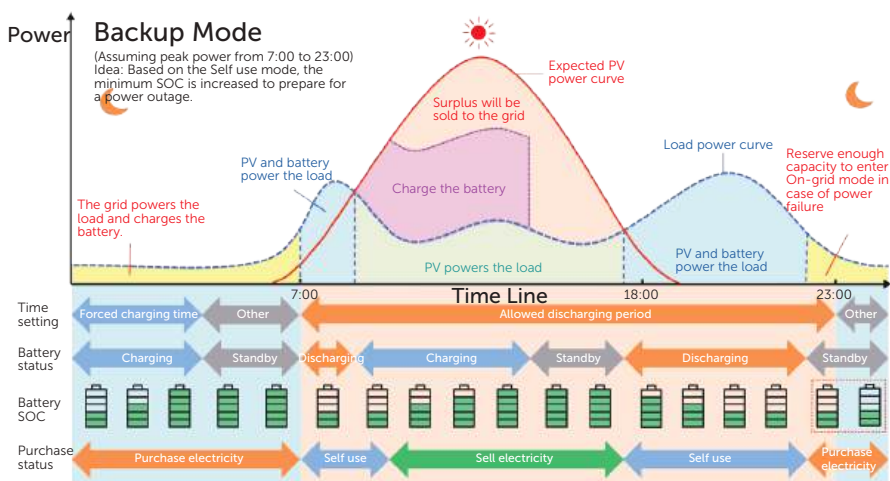

Figure 2-12 Backup mode

Table 2-6 Description of backup mode

Time period	Inverter working status
Forced charging period	Charge the battery first until the battery SOC reaches the specified value for Charge battery to . You can set whether the inverter draws power from the grid or not.

Time period	Inverter working status
Allowed discharging period	<p>Its working logic is basically the same as that in self use mode. The difference lies in:</p> <ul style="list-style-type: none">• In self use mode, the battery goes into hibernation when PV input is not available and the battery SOC reaches Min SOC (on-grid min SOC). In the event of a grid outage, the inverter will not enter EPS mode.• In backup mode, the inverter enters standby state when PV input is not available and the battery SOC reaches Min SOC (on-grid min SOC). In the event of a grid outage, it will switch to EPS mode until the battery discharges to Min SOC (Off-grid min SOC).

Note:

Min SOC (on-grid min SOC): Minimum SOC under grid connection. 30% by default, the settable range is 30%~100%.

Min SOC (off-grid min SOC): Minimum SOC under off-grid conditions. 10% by default, the settable range is 10%~100%.

NOTICE!
<ul style="list-style-type: none">• You can set two working periods: forced charging period and allowed discharging period. Please refer to "Charge & Discharge Period" for details.• If there is a foreseeable power outage, switch from other working modes to the backup mode in advance.

2.7.4 Peak Shaving Mode

Peak shaving mode is set for adjusting power consumption in peak hours. Through intelligent control, it is to ensure that the battery charges during off-peak hours and discharges during peak hours.

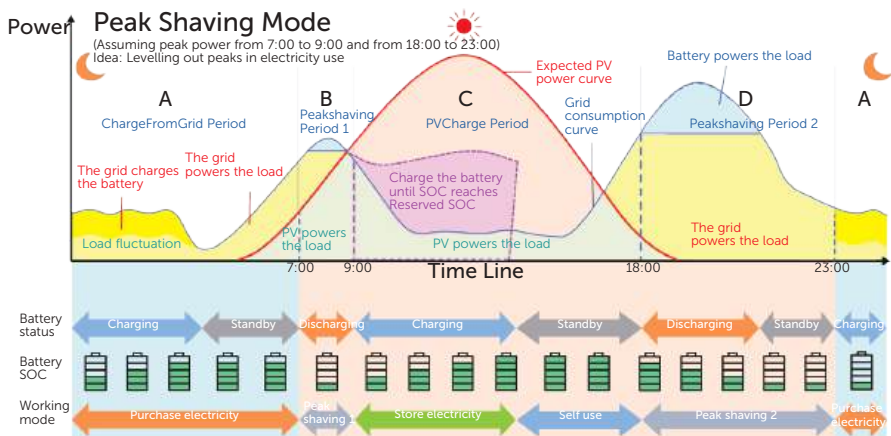

Figure 2-13 Peakshaving mode

Table 2-7 Description of peakshaving mode

Time Period	Inverter working status
Period A	The grid can charge the battery to MaxSOC within the set ChargePowerLimits . In this period, the battery will not discharge.
Period B & D	Grid consumption power < PeakLimits (PV+grid → load) <ul style="list-style-type: none"> The PV and grid will both supply power to the load. The battery will not charge or discharge.
Period C	Grid consumption power > PeakLimits (PV + battery + grid → load) <ul style="list-style-type: none"> The battery will supply energy to loads, so as to reduce the amount of energy purchased from the grid. (PV → battery → load → grid) <ul style="list-style-type: none"> The battery does not discharge. The PV charges the battery up to the Reserved SOC before supplying power to the loads. Any excess power beyond the load requirements is fed into the grid.

Note:

MaxSOC: The maximum amount of energy taken from grid to charge the battery. 50% by default, the settable range is 10%-100%.

ChargePowerLimits: The limit of power of taking power from grid. 1000 W by default, the

settable range is 0-60000 W.

PeakLimits: The limit of power of loads taking power from the grid side. 0 W by default, the settable range: 0-60000 W.

Reserved SOC: The lowest battery SOC set for a peak shaving period. 50% by default, the settable range is 10~100%.

2.7.5 TOU Mode

Different from the above four working modes, TOU mode only be set through the SolaXCloud (App or Web).

In TOU mode, you can divide one year into different periods and set different working modes for different time slots in a day according to the actual needs. One day can be divided into 10 time slots at most. Working modes available to each time slot include: Self use mode, Battery off, Peaking shaving mode, Charging mode, and Discharging mode. For details about how to set the TOU mode, refer to the guide document on the SolaXCloud (App or Web).

Table 2-8 Time slot setting

Time Slot	Working Mode
X:XX~X:XX	Choose one from Self use mode, Battery off, Peaking shaving mode, Charging mode, and Discharging mode.

Note:

Self use mode: Same working logic with "2.7.1 Self-use Mode", but it is not limited by the charging and discharging time slots. You need to set **Min SOC** for this mode.

Battery off: The battery neither charges nor discharges, except when the remaining battery energy is lower than the value of **Min SOC**, which is set at the beginning of creating a TOU.

Peak shaving mode: You need to set the value for **Peak Limit**. When the power consumption exceeds the value of **Peak Limit**, the battery and PV sides will both supply power to the loads, to ensure that the consumed power does not exceed the setting value.

Charging mode: When you set the maximum battery charging power, the PV will charge the battery with the maximum charging power if its energy is sufficient. Besides, you can choose to enable **ChargeFromGrid** and set the target SOC for battery charging. In this way, when power from the PV is insufficient, the battery can be charged by the grid with the maximum charging power.

Discharging mode: If allowed by the battery, the system outputs electricity to the grid according to the specified power output percentage or value, controlling the power at the AC terminal. You need to set a value for **Rate of AC Power** (% or W).

The setting items described above are based on the SolaXCloud V6.2.0, which may change with version upgrade. The final settings should be subject to the actual situations.

2.7.6 EPS Mode (Priority: Loads>Battery)

During power failure, the system will supply constant power to the EPS loads with the power from the PV and battery. It is important to ensure that the total power of EPS loads should not exceed the maximum output power of the battery.

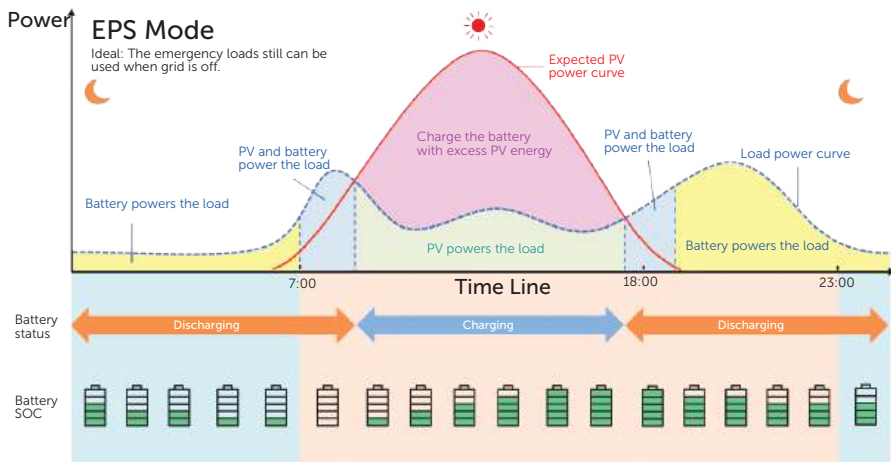

Figure 2-14 EPS mode

Table 2-9 Description of EPS mode

Battery SOC	Inverter working status
Battery SOC >Min SOC (off-grid)	PV is sufficient (PV → load → battery) <ul style="list-style-type: none"> The PV prioritizes supplying power to the load, with any excess energy being directed towards charging the battery.
Battery SOC ≤Min SOC (off-grid)	PV is insufficient (PV+battery → load) <ul style="list-style-type: none"> The PV prioritizes supplying power to the load. If the energy is not enough, the battery will discharge power until the battery SOC reaches Min SOC. At this time, the error of BatPowerLow will be reported.
Battery SOC ≤Min SOC (off-grid)	The inverter reports BatPowerLow . When there is PV input, it will charge the battery first until the battery reaches the Min ESC SOC value. At this time, the inverter will be automatically recovered and enter the EPS mode again.

Note:

Min SOC: Minimum SOC of the battery when the inverter is in off-grid state. 10% by default, the settable range: 10%-100%.

Min ESC SOC: The minimum SOC required for re-entry EPS mode. 30% by default, the settable range: 15%-100%.

2.7.7 Manual Mode

Manual mode is only for the qualified debugging and maintenance personnel. It includes **Forced Discharge**, **Forced Charge** and **Stop Chg&Dischg**. The mode will automatically exit after it has been working for 6 hours.

2.7.8 Export Control

Export control is to control the amount of electricity exported from the PV to the grid. You need to set the export limit value (setting range: 0W ~ (exceed) rated output power) for the inverter. This inverter series has three-phase unbalanced output function. The following shows the export control function when the three-phase unbalanced is enabled and disabled:

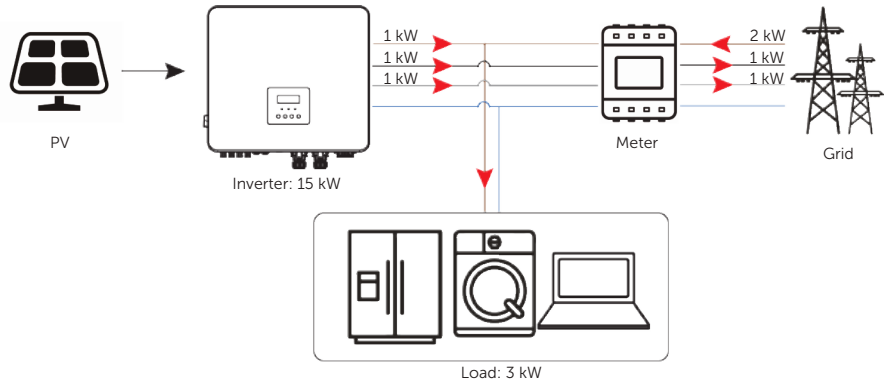

Figure 2-15 Zero export control with **Phase Unbalance** disabled

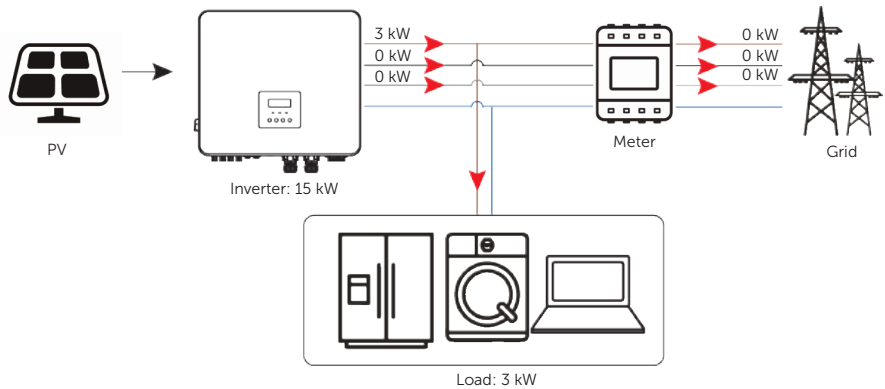

Figure 2-16 Zero export control with **Phase Unbalance** enabled

Note:

For details about setting the **Export Control** function, refer to [“Setting Export Control”](#).

3 System Overview

System Overview

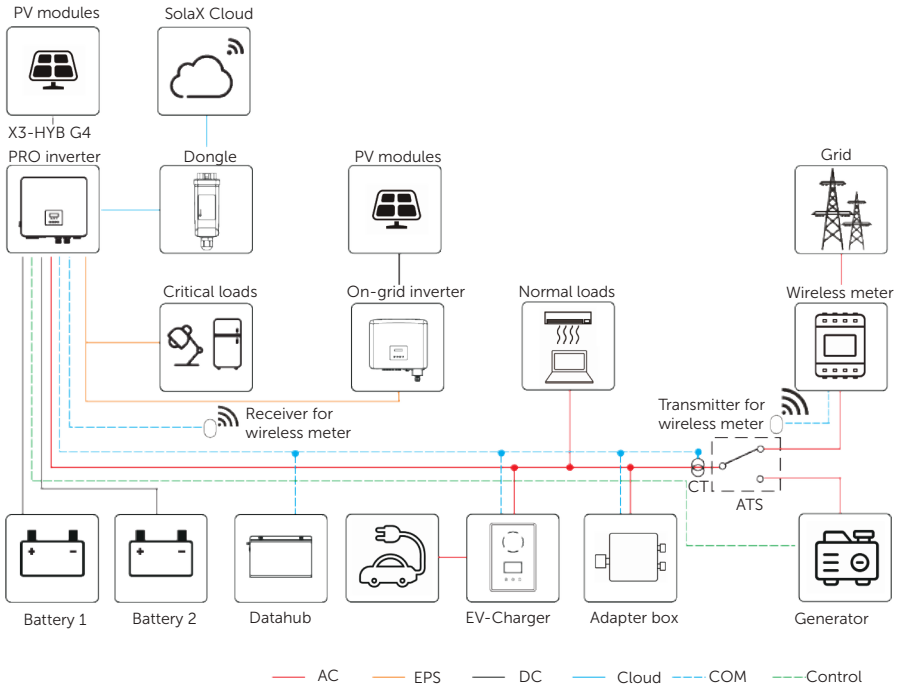

Figure 3-1 System diagram

NOTICE!

The above diagram is only for reference. In practice, some devices cannot be used together. For example, if an on-grid inverter and a generator are connected to the X3-HYB G4 PRO inverter simultaneously, the system will crash.

Table 3-1 System item description

Item	Description
X3-HYB G4 PRO series (the device models covered by this manual)	The X3-HYB G4 PRO series is an energy storage inverter that supports grid connection of a photovoltaic system.
PV modules	PV modules work in MPPT mode. For 4 kW, 5 kW, and 6 kW inverters, the maximum number of MPPTs is 2. For 8 kW, 10kW, 12 kW, and 15 kW inverters, the maximum number of MPPTs is 3.
Battery	The series inverter should be coupled with the lithium-ion battery. Two battery terminals can be connected with two battery clusters. It communicates with the inverter via the BMS terminal and must comply with the specifications of the regulations.
Meter/CT	By reading the meter or CT data, the inverter can control the battery to charge or discharge, so as to achieve intelligent energy management. Besides, the inverter supports the wireless meter solution.
Additional on-grid inverter (supported)	The series inverter supports micro-grid function. By connecting another inverter to the EPS terminal of the current inverter, the current inverter plays as the grid to supply power to another inverter during the off-grid period. Please refer to "15.5 Application of Micro-grid" for specific wiring and setting.
Adapter box G1/G2 (supported)	You can connect a heat pump to the energy storage system via an adapter box, so as to control the heat pump. Please refer to "15.2 Application of Adapter Box" for specific wiring and setting.
Datahub (supported)	Datahub is a professional device for data collection and storage, export control, integrated monitoring, and integrated maintenance. It serves the inverter, meter, environment monitoring equipment in the photovoltaic system. Please refer to "15.4 Application of Datahub" for specific wiring and setting.
EV-Charger (supported)	The series inverter can communicate with SolaX EV-Charger to form an intelligent photovoltaic, storage and EV charging energy system, thus maximizing the utilization of photovoltaic energy. Please refer to "15.3 Application of EV-Charger" for specific wiring and setting.
Generator (supported)	The generator solution offers a stable and reliable power supply, and meanwhile lowers energy costs. Please refer to "15.1 Application of Generator" for specific wiring and setting.
Grid	400 V / 230 V and 380 V / 220 V grid are supported.

Item	Description
SolaXCloud	SolaXCloud is an intelligent, multifunctional monitoring platform that can be accessed in a wired or wireless way. With the SolaXCloud, operators and installers can view important and up-to-date data at any time.

4 Transportation and Storage

If the inverter is not put into use immediately, the transportation and storage requirements need to be met:

Transportation

- The inverter must be transported in its original packaging. SolaX will not be responsible for any damage to the inverter caused by improper transportation or by transportation after it has been installed.
- Observe the caution signs on the packaging of inverter before transportation.
- Pay attention to the weight of the inverter. Carry the inverters by the required number of personnel as specified by local regulations (Gross weight of X3-HYB G4 PRO: 45 kg).
- Wear protective gloves and safety shoes when carrying the equipment to prevent injuries.
- When lifting up the inverter, hold the handle and bottom of the carton. Keep the inverter horizontal in case of falling down.

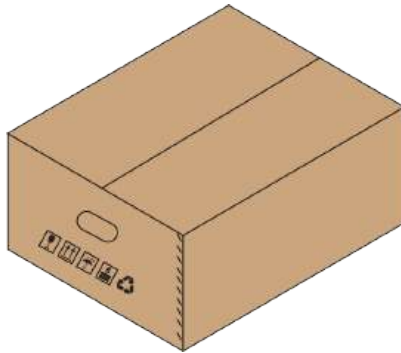

Figure 4-1 Caution signs on the packaging

Storage

- The inverter must be stored indoors.
- Do not remove the original packaging material and check the outer packaging material regularly.
- The storage temperature should be between -40°C and $+65^{\circ}\text{C}$. The relative humidity should be between 35% and 70%.
- Stack inverters in accordance with the caution signs on the inverter carton to prevent device damage caused by falling down. Do not place it upside down.

5 Preparation before Installation

5.1 Selection of Installation Location

A good installation location is critical to the safety, service life and performance of the inverter. This inverter has the IP66 ingress protection, so it can be installed outdoor. Besides, the installation location should be selected for convenience of wire connection, operation and maintenance.

5.1.1 Environment Requirement

- Ambient temperature: -35°C to $+60^{\circ}\text{C}$.
- Relative humidity: 0 to 100% (condensing).
- Do not install the inverter in the areas where the altitude exceeds 3000 m.
- Install the inverter in a well-ventilated environment for heat dissipation. It is recommended to install an awning over the inverter if it is installed on an outdoor support.
- Do not install the inverter in areas with flammable, explosive and corrosive materials or near antennas.
- Avoid direct sunlight, rain exposure and snow accumulation.

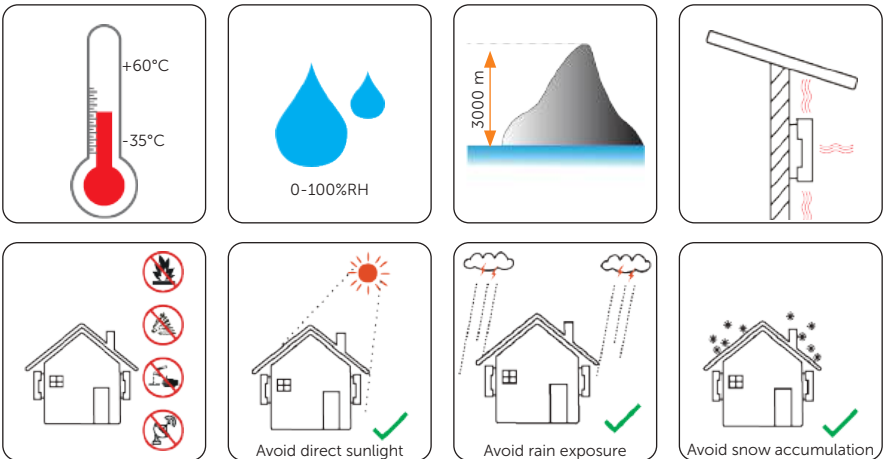

NOTICE!

- For outdoor installation, precautions against direct sunlight, rain exposure and snow accumulation are recommended.
- Exposure to direct sunlight raises the temperature inside the device. This temperature rise poses no safety risks, but may impact the device performance.
- Install the inverter at least 500 meters away from the coast and avoid direct blowing and hitting of sea breeze.

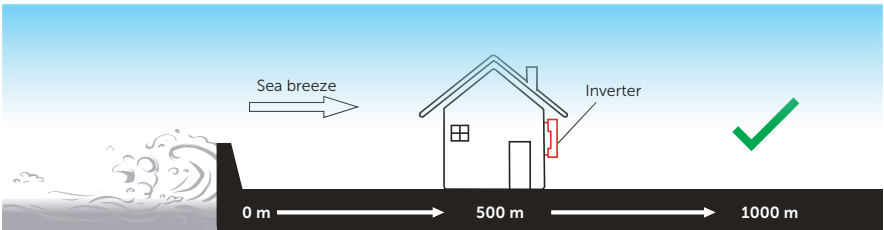

Figure 5-1 Recommended installation position

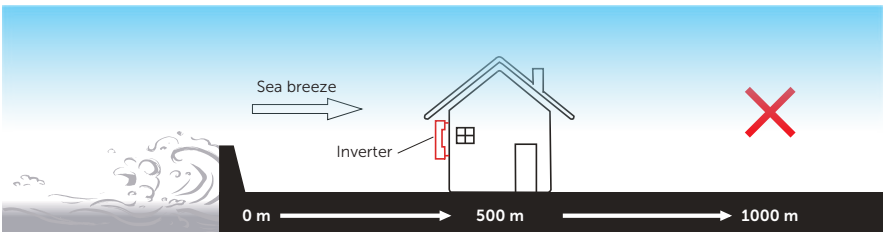

Figure 5-2 Incorrect installation position

NOTICE!

For installation of the whole system, please refer to the specific environment requirement of each unit.

5.2 Installation Carrier Requirement

The installation carrier must be made of a non-flammable material, such as solid brick, concrete. It should be capable of supporting the weight of the inverter and suitable for the dimensions of the inverter. If the load-bearing capacity of a wall is not high (such as wooden wall and wall covered by a thick layer of decoration), it must be improved accordingly.

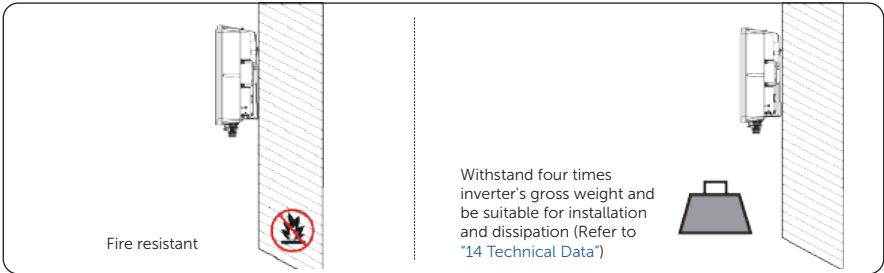

Figure 5-3 Installation carrier requirement

NOTICE!

Please take the weight of battery into account when installing the whole system onto the wall.

5.2.1 Clearance Requirement

The minimum clearance reserved for connecting wires to terminals at the bottom of inverter should be 13.5 cm. You also should take the bending radius of the wires into consideration.

Besides, to guarantee proper heat dissipation and ease of disassembly, the minimum space around the inverter must meet the requirements below:

- **For a single inverter:** The bottom must be at least 50 cm away from the ground. Its Above, Left, Right, and Front must keep a minimum distance of 30 cm with other objects.
- **For multiple inverters:** The interval between two inverters should be at least 30 cm transversely and 100 cm longitudinally. In addition, the row of inverters at the bottom should be at least 50 cm above the ground. In areas with high ambient temperatures, increase the spacing between inverters appropriately, to maintain good ventilation.

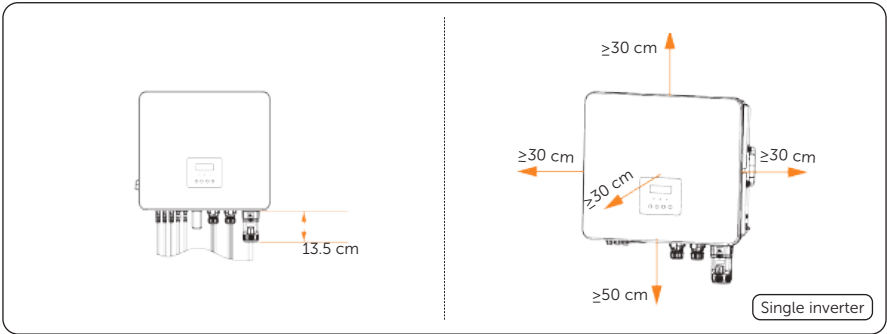

Figure 5-4 Clearance requirement for single inverter

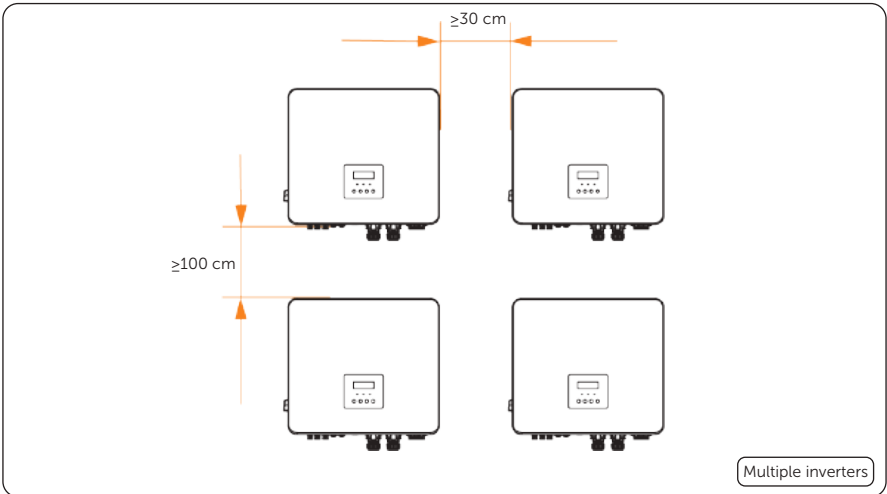

Figure 5-5 Clearance requirement for multiple inverters





5.3 Tools Requirement

Installation tools include but are not limited to the following recommended ones. If necessary, use other auxiliary tools on site. Please note that the tools used must comply with the local regulations.

 Hammer drill (drill bit: Ø10 mm)	 Multimeter (> 1100 V DC)	 Measuring tape	 Utility knife
 Marker	 Torque screwdriver (Flat-head: M2) (Phillips head: M2.5 / M3 / M5)	 Spirit level	 Allen key (including M5 wrench)
 Wire stripper	 Crimping tool for RJ45 terminal	 Crimping tool for PV terminals	 Diagonal pliers
 Crimping tool	 Crimping tool for ferrules	 Wire cutter	 Rubber mallet
 Torque wrench	 Heat gun	 Heat shrink tubing (Ø6 mm)	 15 mm open-end wrench
 Safety gloves	 Safety boots	 Safety goggles	 Anti-dust mask

5.4 Additionally Required Materials

Table 5-1 Additionally required wires

No.	Required Material	Type	Conductor Cross-section
1	PV cable	 Dedicated PV cable with a voltage rating of 1000 V, a temperature resistance of 105°C, a fire resistance grade of VW-1	4 mm ²
2	Communication cable	 Network cable CAT5E	/
3	PE cable	 Conventional yellow and green cable	6 mm ²
4	Battery cable (if required)	 UL cable	6 mm ²

NOTICE!

X3-Matebox G2 users do not need to prepare the battery wire because it has been included in the accessory pack. For specific installation steps, please refer to *X3-Matebox G2 Series Installation Manual*.

- Breaker and cable recommended for grid connection (with EPS)

Inverter model	4 kW	5 kW	6 kW	8 kW	10 kW	12 kW	15 kW
Breaker (A)	20	20	20	32	40	40	40
Five-core cable (mm ²)	4 ~ 6	4 ~ 6	4 ~ 6	4 ~ 6	6	6	6

- Breaker and cable recommended for grid connection (without EPS)

Inverter model	4 kW	5 kW	6 kW	8 kW	10 kW	12 kW	15 kW
Breaker (A)	10	16	16	20	25	25	32
Five-core cable (mm ²)	4 ~ 6	4 ~ 6	4 ~ 6	4 ~ 6	6	6	6

- Breaker and cable recommended for off-grid connection (only EPS)

Inverter model	4 kW	5 kW	6 kW	8 kW	10 kW	12 kW	15 kW
Breaker (A)	10	10	16	16	20	25	32
Five-core cable (mm ²)	4 ~ 6	4 ~ 6	4 ~ 6	4 ~ 6	6	6	6

6 Unpacking and Inspection

6.1 Unpacking

- The inverter undergoes 100% testing and inspection before delivery. However, damages may still occur during transportation. Before unpacking, please carefully check the external packaging for any signs of damage, such as punctures or cracks.
- Unpacking the inverter according to the following figure.

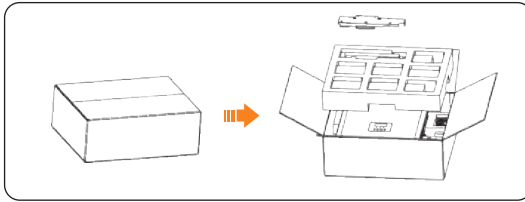

Figure 6-1 Unpacking the inverter

- Properly handle all the packaging materials in case they may be reused for storage and transportation of the inverter in the future.
- Upon opening the package, check whether the inverter is intact and whether all accessories are included. If any damage is found or any parts are missing, contact your dealer immediately.

6.2 Scope of Delivery

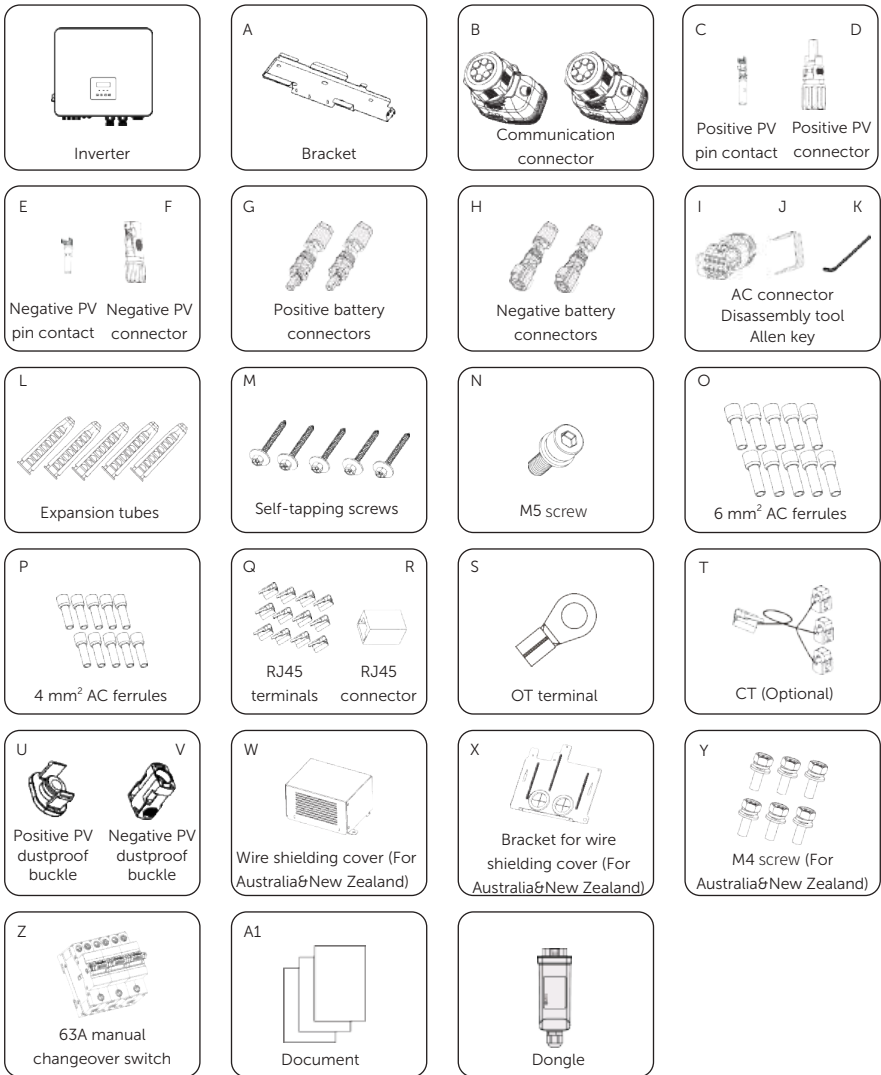

Table 6-1 Packing list

Item	Description	Quantity	Remarks
/	Inverter	1 pc	

Item	Description	Quantity	Remarks
A	Bracket	1 pc	
B	Communication connector	2 pcs	Used for connecting the communication cable to the communication terminal.
C	Positive PV pin contact	<ul style="list-style-type: none"> • 2 pcs for 4 kW, 5 kW, and 6 kW inverters • 3 pcs for 8 kW, 10 kW, 12 kW, and 15 kW inverters 	Used for connecting to the PV terminal.
D	Positive PV connector		
E	Negative PV pin contact		
F	Negative PV connector		
G	Positive battery connectors	2 pcs	Used for connecting to the battery terminal.
H	Negative battery connectors	2 pcs	
I	AC connector	1 pc	
J	Disassembly tool	1 pc	
K	Allen key	1 pc	Used for tightening the screw on the AC connector.
L	Expansion tubes	5 pcs	Used to fix the bracket.
M	Self-tapping screws	5 pcs	Used to fix the bracket.
N	M5 screw	1 pc	Used to fix the inverter.
O	6 mm ² AC ferrule	10 pcs	Used for wiring to terminal Grid&EPS. It's suitable for all inverter models in this series.
P	4 mm ² AC ferrule*	10 pcs	Used for wiring to terminal Grid&EPS. It's only suitable for 4 kW, 5 kW, 6 kW, and 8 kW inverters.
Q	RJ45 terminals	12 pcs	Used for connecting to sub-terminals of terminals COM1 and COM2.
R	RJ45 connector	1 pc	Used for connecting CTs .
S	OT terminal	2 pcs	Used for connecting the ground wire to the inverter.

Unpacking and Inspection

Item	Description	Quantity	Remarks
T	CT (Optional)	1 pc	<ul style="list-style-type: none"> For inverters equipped with CT, their packaging box is marked with "CT". For inverters equipped with meter, their packaging box is marked with nothing.
U	Positive PV dustproof buckles	• 2 pcs for 4 kW, 5 kW, and 6 kW inverters	Used to shield from dust.
V	Negative PV dustproof buckles	• 3 pcs for 8 kW, 10 kW, 12 kW, and 15 kW inverters	
W	Wire shielding cover	1 pc	Only for Australia and New Zealand. Used to protect the PV and battery power cables.
X	Bracket for wire shielding cover	1 pc	Only for Australia and New Zealand. Used to support the wire shielding cover.
Y	M4 screw	6 pcs	Only for Australia and New Zealand. Used to fasten the wire shielding cover and bracket.
Z	63A manual changeover switch	1 pc	Only for Australia and New Zealand. Used to switch to the bypass circuit.
A1	Document	/	
/	Dongle	1 pc	Used for communication between the inverter and SolaXCloud. Equipped with dongle pocket Wi-Fi+LAN, but also support dongle pocket Wi-Fi+4G. Contact us if you want to purchase it.

NOTICE!

- The optional accessories are subject to the actual delivery.
- “*”: For 4, 5, 6, and 8 kW inverters, 6 mm² and 4 mm² AC ferrules are both available to you. Please select it according to the diameter of your Grid & EPS cable.

7 Mechanical Installation

WARNING!

- Only qualified personnel are allowed to perform the mechanical installation in accordance with local laws and regulations.
- Check the existing power cables or other piping in the wall to prevent electric shock or other damage.
- Use insulated tools and wear personal protective equipment throughout the installation and maintenance process.

CAUTION!

During installation, always be cautious about the weight of the inverter. Improper lifting or dropping of the inverter may result in personal injury.

NOTICE!

Install the inverter at a maximum back tilt of 5 degrees and avoid it being forward tilted, side tilted, or upside down.

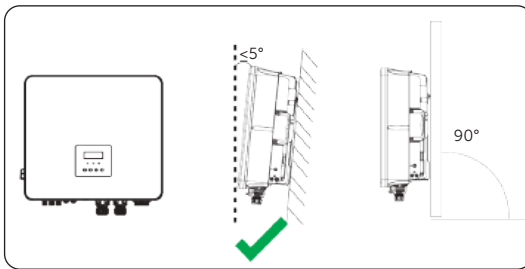

Figure 7-1 Correct installation

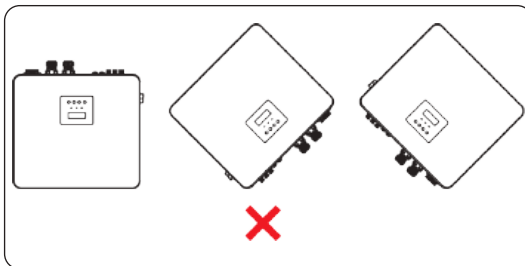

Figure 7-2 Incorrect installation

7.1 Dimensions for mounting

The figure below shows dimensions of the inverter. Please reserve enough separation space for the inverter, to ensure proper heat dissipation and easy disassembly. For details, refer to "5.2.1 Clearance Requirement".

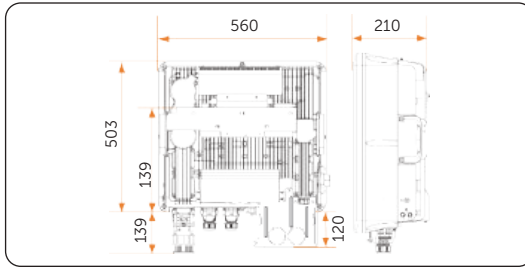

Figure 7-3 Dimensions (Unit: mm)

7.2 Installation procedure

According to Australian regulations, a wire shielding cover must be installed, to protect the PV and battery cables. However, there is no such regulations in other countries and regions. The following provides the whole procedure for installing a wire shielding and an inverter.

Please select proper steps according to your country or region:

- For users in Australia and New Zealand: Follow all the steps below.
- For users in the other countries or regions: Follow steps 2 to 7.

Step 1: Take the inverter out and put it down with its back upwards. Also take the bracket (part X) from the accessory bag also with its back upwards and then put it onto the lower right corner of the inverter. Align the preserved screw holes with each other. Put screws (part Y) into the holes and tighten them with a screwdriver.

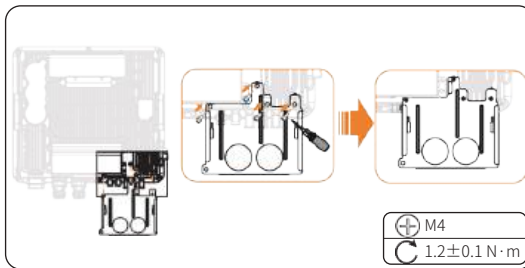

Figure 7-1 Installing the bracket

NOTICE!

When placing the inverter onto the ground, cushion its bottom with foam or other protective materials, to avoid damage to the inverter.

Step 2: Put the bracket (part A) onto the surface of the wall. Use a spirit level to make the bracket horizontal. Draw hole-drilling marks with the marker.

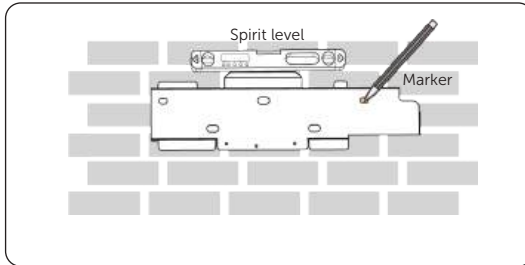

Figure 7-2 Marking the holes

NOTICE!

- **Inverter without battery:** Keep the device bottom at least 50 cm above the ground. A distance of more than 140 cm is preferred for a single inverter.
- **Inverter with battery:** Reserve enough space for batteries. For details about dimensions of battery, refer to the corresponding battery manual.

Step 3: Aim the hammer drill (bit: $\varnothing 10$ mm) at the centre of the markers and drill 5 holes with a depth of more than 60 mm. Insert 5 expansion tubes (part L) into the holes sequentially until the top of tubes are flush with the wall surface. If not flush enough, drive them with a rubber hammer.

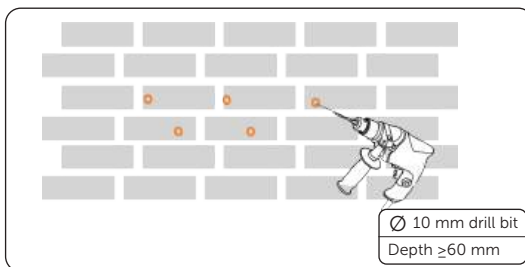

Figure 7-3 Drilling holes

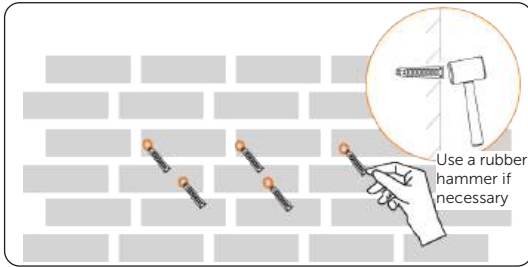

Figure 7-4 Driving expansion tubes into the wall

Step 4: Attach the bracket (part A) to the wall, with expansion tubes going through the reserved holes of the bracket. Insert self-tapping screws (part M) into the expansion tubes. Tighten the screws with a torque wrench (size: 10 mm).

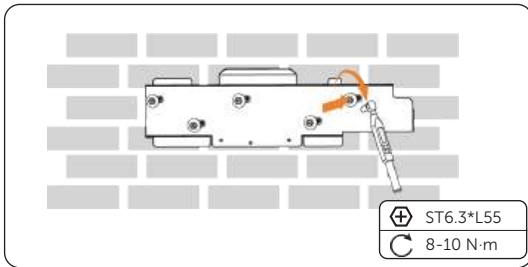

Figure 7-5 Securing the bracket

Step 5: Pull out the handles from both sides of the inverter. Lift up the inverter collaboratively by the number of personnel in accordance with the local regulation and hang it onto the bracket. Make sure that the keyway on the back of the inverter is accurately put into the hooking groove of the bracket.

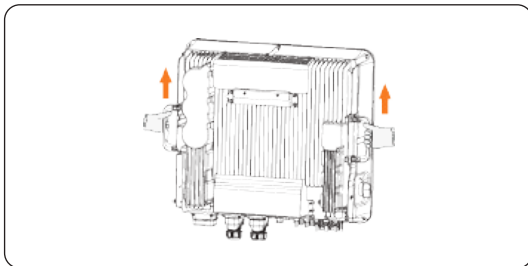

Figure 7-6 Pulling out the handles and lifting the device up

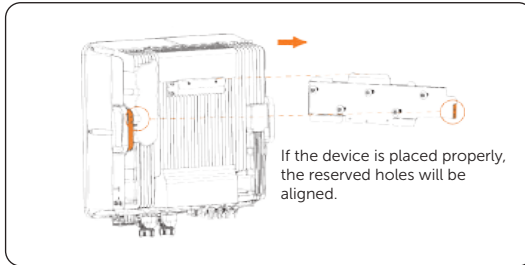

Figure 7-7 Hanging the device onto the bracket

NOTICE!

- When placing the inverter onto the ground, cushion its bottom with foam or other protective materials, avoid damage to the inverter.
- Prevent terminals of the device from directly colliding with the ground or other objects, to reduce damage to the terminals.

Step 6: Use a M5 screw (part N) to secure the inverter.

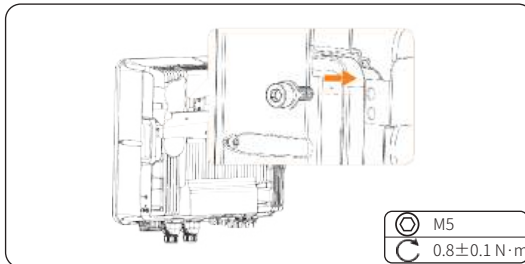

Figure 7-8 Securing the inverter

Step 7: (Optional) Install an anti-theft lock. The anti-theft lock is not in the scope of delivery. If necessary, prepare a lock with a diameter $\varnothing 5$ mm by yourself, and keep the key to the lock properly.

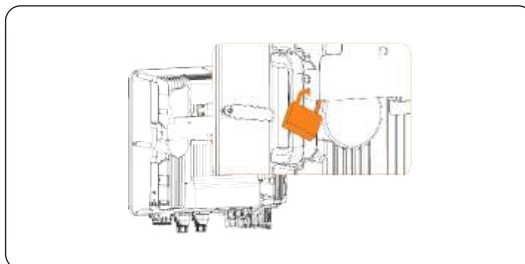

Figure 7-9 Locking the inverter

Step 8: Cut the wire protection ring along the cross-shaped dent with a utility knife.

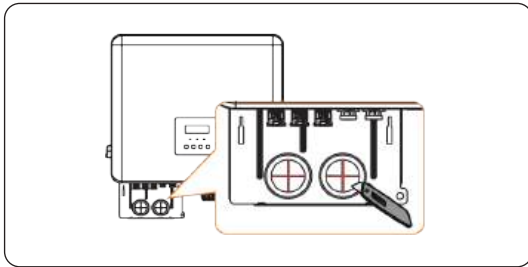

Figure 7-10 Cutting the wire protection ring

Step 9: Handle the PV cables and battery power cables according to steps 1 to 6 in "8.4 PV Connection" and steps 1 to 4 in "8.5 Battery Power Cable Connection", respectively. Put two types of cables together and sort them into two bundles by polarity. As shown in this figure, thread the two bundles through two holes of the bracket separately. Connect the PV cables and battery power cables to the PV and battery terminals respectively according to steps 7 and 8 in "8.4 PV Connection" and step 5 in "8.5 Battery Power Cable Connection".

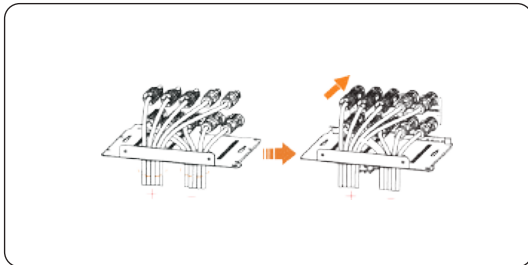

Figure 7-11 Sorting and threading cables

Step 10: Take a wire shielding cover (part W) out from the accessory bag. Put the hook of the cover into the hole on the bracket, and then support the cover with one hand. Secure the cover with two screws.

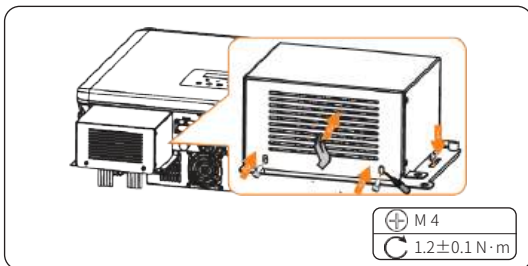

Figure 7-12 Securing the wire shielding cover

Step 11: (Optional) Lock the wire shielding cover with a $\varnothing 5$ mm lock. Please prepare the lock by yourself.

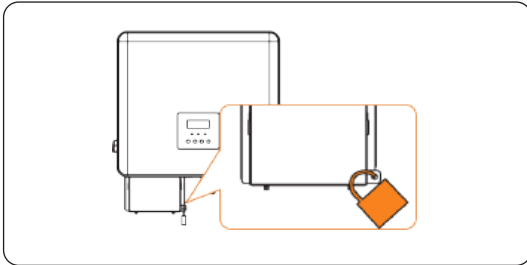

Figure 7-13 Locking the wire shielding cover

8 Electrical Connection

DANGER!

- Before electrical connection, make sure the DC switch and AC breaker are disconnected. Otherwise, the high voltage might cause electric shock, resulting in severe personal injuries or even death.

WARNING!

- Only qualified personnel are allowed to perform the electrical connection according to the local laws and regulations.
- Strictly follow the instructions of this manual or other related documentation for electrical connection. Inverter damages caused by incorrect wiring are not covered by the warranty.
- Use insulated tools and wear personal protective equipment throughout the electrical connection process.

8.1 Overview of Electrical Connection

8.1.1 Terminals and Parts of Inverter

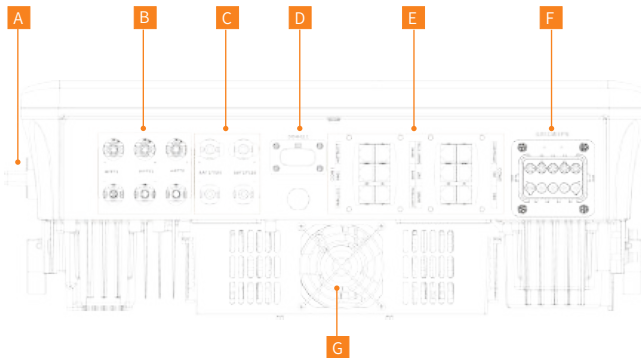

Figure 8-1 Terminals and parts of Inverter

Table 8-1 Description of terminals and parts

Item	Name	Description	Decisive voltage class
A	DC switch		/
B	MPPT terminals	For inverters 4 kW, 5 kW, and 6 kW, MPPT1 and MPPT2 are available. For inverters 8 kW, 10 kW, 12 kW, and 15 kW, MPPT1, MPPT2, and MPPT3 are available.	DVC-C
C	BAT/V2X terminals	It is used to connect a battery cluster or V2X (Vehicle to X) module. Two battery clusters connecting two BAT/V2X terminals may be different in model but their battery modules must be the same in model.	DVC-C
D	Dongle terminal	Through this terminal, the dongle pocket can establish a connection with the inverter and upload the data to the SolaXCloud.	DVC-A
E	COM 1 terminal	It is used for communication, including sub-terminals Parallel 1, Parallel 2, BMS 1, BMS 2, RS485, and Meter/CT.	DVC-A
	COM 2 terminal	It is used for communication, including sub-terminals DI/DO, EVC, SMART CTRL (or DATAHUB), DRM, V2X, and Heatpump.	
F	Grid & EPS terminal		DVC-C
G	Fan		/

8.1.2 Cable Connections of Inverter

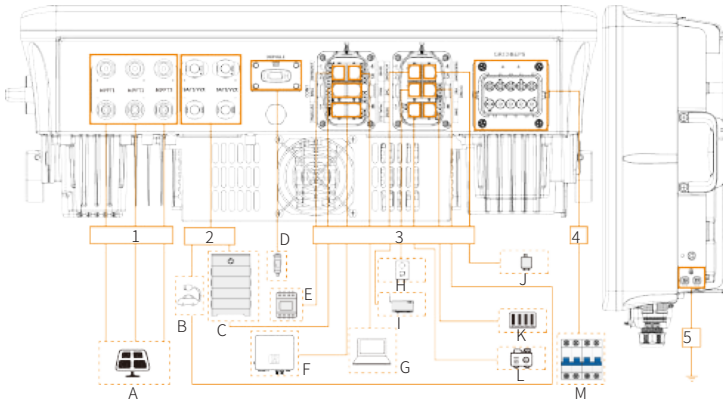

Figure 8-2 Cable connections of inverter

Table 8-2 Description of connected parts

Item	Part	Description	Source
A	PV module	A PV string is formed of PV modules connected in string. The number of PV modules in a string varies with the model.	Prepared by user
B	V2X module	It connects to a new energy electric vehicle, to manage charging and discharging of the in-vehicle battery.	Purchased from SolaX
C	Battery	Support battery systems T-BAT-SYS-HV-S25, T-BAT-SYS-HV-S36, T-BAT-SYS-HV-3.0, T-BAT-SYS-HV-S50E-D, T-BAT-SYS-HV-S51, and T-BAT-SYS-HV-5.8 (T58 & T58 V2 & T58 V3).	Purchased from SolaX
D	Monitoring module	Only support the SolaX monitoring module.	Purchased from SolaX
E	Meter/CT	Support the meter and CT authorized by SolaX: DTSU666 and DTSU666-CT.	Purchased from SolaX
F	(Optional) X3-HYB G4 PRO series inverter	Select an inverter of the same power range.	Purchased from SolaX
G	External device	All external devices that support the Modbus protocol, for example computer.	Prepared by user

Item	Part	Description	Source
H	EV-Charger	Support EV-Charger.	Purchased from SolaX
I	Datahub	Support datahub.	Purchased from SolaX
J	Adapter box	Support adapter box G1 and G2.	Purchased from SolaX
K	Power grid management equipment (only used in Australia and New Zealand)	Select the devices that meet the requirements on power grid management.	Prepared by user
L	(Optional) Device controlled through dry contact	Support generator and system switch. <ul style="list-style-type: none"> For generator, select a generator equipped with an ATSE (Automatic Transfer Switching Equipment), and make sure that "Load power + Battery charging power < Rated output power of the generator". For system switch, select a self-locking switch. 	Prepared by user
M	AC circuit breaker	Select an appropriate AC switch according to the local regulations, to ensure the inverter can be securely disconnected from the grid when an emergency occurs. Refer to " 5.4 Additionally Required Materials " for the recommended specifications of AC switch.	Prepared by user

Table 8-3 Descriptions of cables

Item	Cable	Type and specifications	Source
1	PV cable		Prepared by user
2	Battery power cable	Refer to " 5.4 Additionally Required Materials ".	Prepared by user, except that you have purchased the X3-Matebox G2
3	Communication cable		Prepared by user
4	Grid & EPS cable		Prepared by user
5	PE cable		Prepared by user

8.2 PE Connection

The inverter must be reliably grounded. The PE connection point is marked with .

PE connection procedures

Step 1: Strip the insulation of the PE cable to an appropriate length.

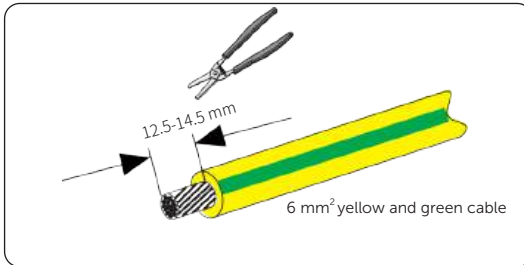

Figure 8-3 Stripping the PE cable

Step 2: Prepare a heat-shrink tubing with a length of 28-30 mm. Thread the stripped PE cable through the heat-shrink tubing until it goes into the OT terminal (part S).

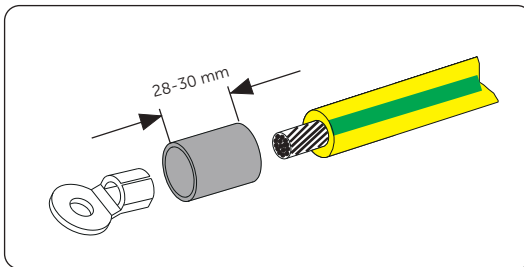

Figure 8-4 Installing the tubing and OT terminal

Step 3: Crimp the PE cable and OT terminal together with a crimping tool. Move the heat-shrink tubing, to make it surround the just crimped parts. Crimp the tubing and shape it with a heat gun.

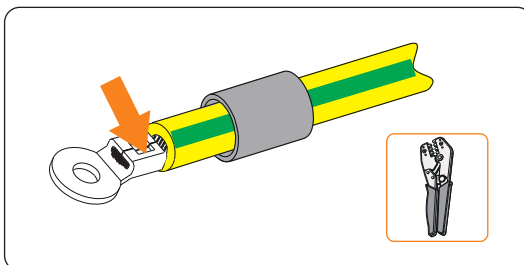

Figure 8-5 Crimping the cable

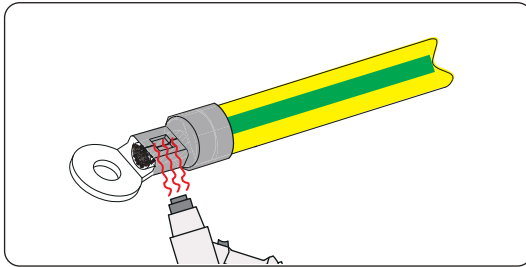

Figure 8-6 Shrinking the tubing

Step 4: Remove the PE screw from the inverter with an Allen key.

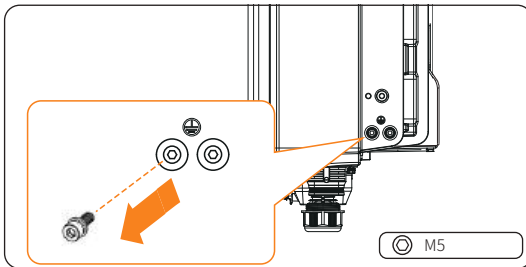

Figure 8-7 Removing the screw

NOTICE!

This inverter has two PE connection points. You can choose either of them.

Step 5: Connect the assembled PE cable to the PE connection point of the inverter, and secure it with the original screw.

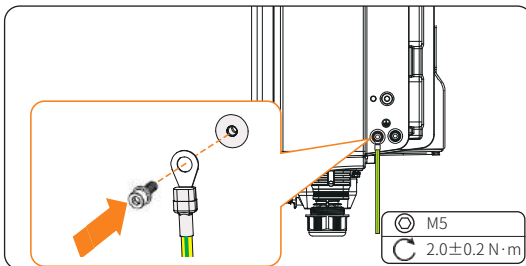

Figure 8-8 Securing the PE cable

8.3 AC Connection

NOTICE!

According to the national and state interconnection regulations, you must be approved by the local utility before connecting the inverter to the grid.

The inverter supports the EPS mode. When connected to the grid, the output of the inverter goes through the Grid terminal, and when disconnected from the grid, the output of the inverter goes through the EPS terminal.

Requirements for AC connection

- Grid voltage requirement

The grid voltage and frequency must be within the allowable range (400 V / 230 V, 380 V / 220V, 50 / 60 Hz) and comply with the requirements of the local power grid.

- Residual Current Device (RCD)

The inverter does not require an external RCD during running. If an external RCD is required by local regulations, a 300-mA Type-A RCD is recommended. If required by local regulations, a Type-B RCD is also permitted.

- AC breaker

An AC breaker that matches the power of the inverter must be used between the inverter output end and the power grid. Each inverter must be equipped with an independent breaker or other load disconnection unit, to ensure a safe disconnection from the grid. For specific information on the AC breaker for Grid and EPS, refer to "5.4 Additionally Required Materials".

- EPS load

- » Make sure the rated power of the EPS load is within the rated output power range of the inverter. Otherwise, the inverter will report an alarm of **EPS Overload Fault**. In this case, turn off some loads to make the power fall within the rated EPS output power range, and then press the **ESC** key on the LCD screen to clear the fault.

- » When connecting to the EPS terminal, pay attention to the following points:

Medical equipment	Connection prohibited
Precision instrument	Connection prohibited
Appliances susceptible to malfunctions due to power outages	Connection prohibited

- » For inductive loads such as refrigerators and air conditioner, ensure that their start power does not exceed the EPS peak power of the inverter.

Table 8-4 EPS load information

Type of load	Equipment	Start power
Resistive load	Lamp	Rated power
	Fan	3-5 times rated power
Inductive load	Hair dryer	3-5 times rated power
	Refrigerator	3-5 times rated power
	Air conditioner	3-6 times rated power
	Washing machine	3-5 times rated power
	Microwave oven	3-5 times rated power

*The actual start power of equipment is subject to the actual nominal start power.

Wiring procedure

NOTICE!

Here take "connecting to Grid and EPS sides at the same time" as an example. In actual situations, you might only connect to the Grid side. Please make corresponding adjustments according to the actual situations.

Step 1: Prepare two five-core cable as Grid and EPS cables. Strip the insulations of conductors L1, L2, L3, N and PE to an appropriate length.

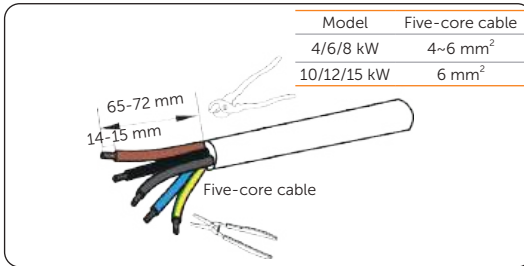

Figure 8-9 Stripping the Grid and EPS cables

Step 2: Insert conductor L1, L2, L3, N and PE of the Grid and EPS cables into ferrules (part O or P) separately. Crimp each ferrule and conductor together with a crimping tool. Make sure the conductors are correctly assigned and firmly seated in the ferrules.

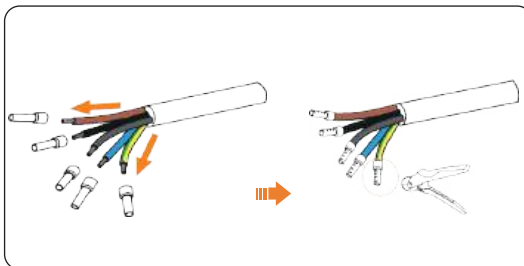

Figure 8-10 Crimping core and ferrule together

Step 3: Take out the AC connector (part I) from the accessory pack. Disassemble the AC connector.

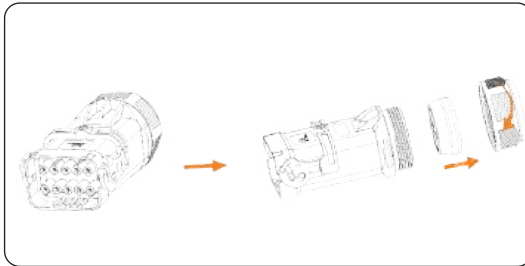

Figure 8-11 Disassembling the AC connector

- » Cut the innermost round membrane with a utility knife.

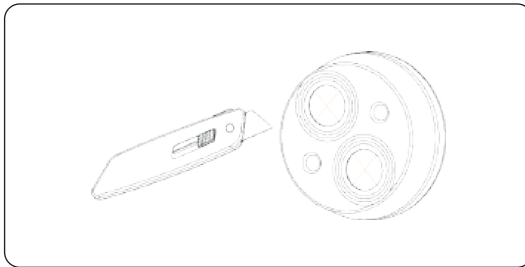

Figure 8-12 Cutting the round membrane

NOTICE!

If only one round hole is needed, please do not cut the other round membrane, to ensure the sealing of the inverter.

- » According to the outside diameters of the cable, take out the corresponding sealing plug with your hand.

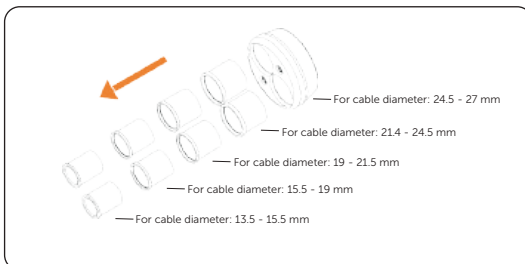

Figure 8-13 Taking out sealing plug

- » Insert the disassembly tool (part J) for the rubber core into the AC connector. Press the disassembly tool with one hand, and meanwhile poke the rubber core from the other end of the AC connector with a screwdriver held by the other hand, until the rubber core is poked out of the enclosure of the AC connector.

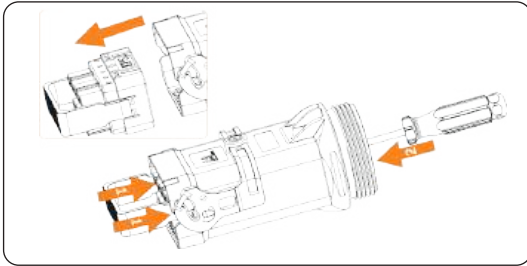

Figure 8-14 Poking the rubber core out

- Step 4:** Thread the Grid and EPS cables through the swivel nut, cable support sleeve, and the enclosure separately. Insert the crimped conductors L1, L2, L3, N, and PE into the corresponding position of the rubber core and tighten them.

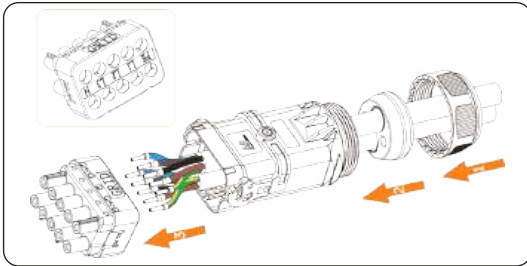

Figure 8-15 Threading and tightening conductors

- » For Grid: Insert Conductor L1 of the Grid cable into Position L1 of the Grid side of the rubber core. Observe whether the conductor is in the right place through the hole of the rubber core. If yes, tighten the screw with the Allen key (part K). Connect L2, L3, N, and PE in the same way.

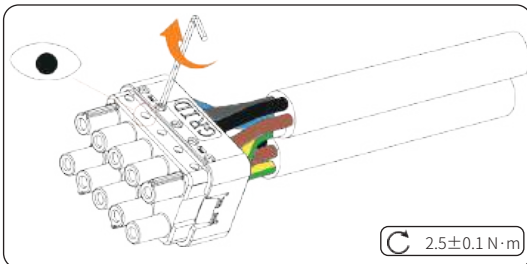

Figure 8-16 Inserting the Grid cable into the rubber core and tightening

- » For EPS: Insert Conductor L1 of the EPS cable into the L1 position of the EPS side of the rubber core. Observe whether the conductor is in the right place through the hole of the rubber core. If yes, tighten the screw with the Allen key (part K). Connect L2, L3, N, and PE in the same way.

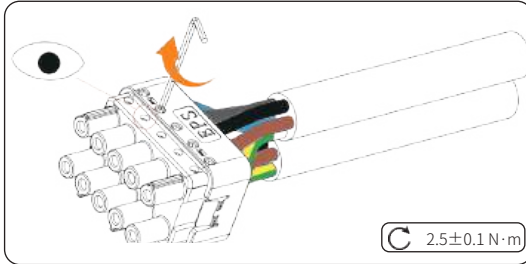

Figure 8-17 Inserting the EPS cable into the rubber core and tightening

- Step 5:** Put the rubber core and cable support sleeve back to the AC connector enclosure, and tighten the swivel nut.

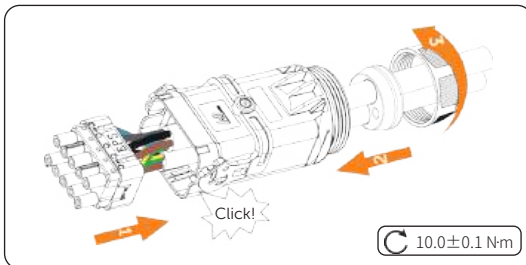

Figure 8-18 Assembling the AC connector

- Step 6:** Remove the cap from the Grid & EPS terminal. Pull the latch on the AC connector up.

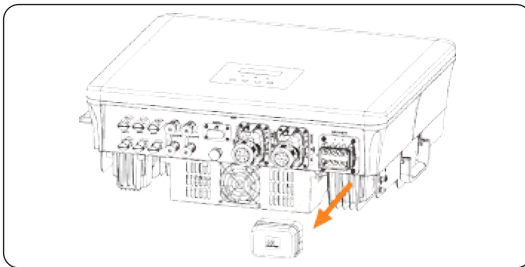

Figure 8-19 Removing the cap

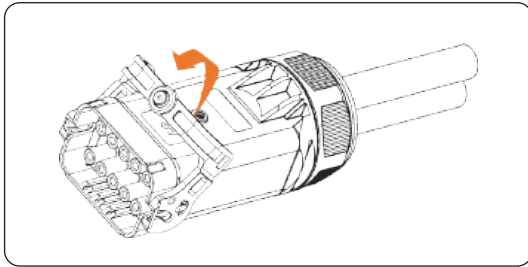

Figure 8-20 Pulling the latch up

Step 7: Insert the AC connector into the Grid & EPS terminal. If your operation is correct, the latch will automatically go back to the previous location. Lock the AC connector with an Allen key.

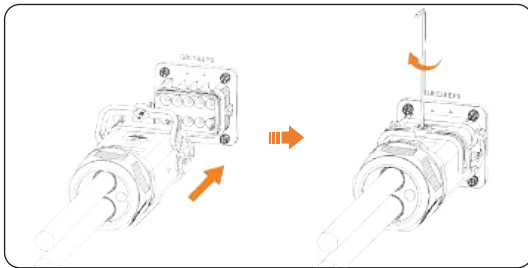

Figure 8-21 Inserting the AC connector into the terminal and locking it

 **WARNING!**

- Reinstall the cap for the AC & Grid terminal immediately after removing the connector from the terminal.

8.4 PV Connection

DANGER!

- When exposed to the sunlight, PV modules will generate lethal high voltage. Please take precautions.
- Before connecting the PV modules, make sure that both DC switch and AC breaker are disconnected, and that the PV module output is securely isolated from the ground.

WARNING!

- To mitigate the risk of fire, it is crucial to utilize a dedicated crimping tool specifically designed for PV installations to ensure secure and reliable connections.

CAUTION!

- Power is fed from more than one source and more than one live circuit.

Requirements for PV connection

- Open circuit voltage and operating voltage
 - » The open circuit voltage of each module array cannot exceed the maximum PV input voltage (1000 V) of the inverter. Otherwise, the inverter may be damaged.
 - » The operating voltage of PV modules must be within the MPPT voltage range (110-950 V) of the inverter. Otherwise, the inverter will prompt a **PV Volt Fault** alarm. Consider the impact of low temperature on the voltage of the photovoltaic panels, as lower temperatures tend to result in higher voltages.
- PV module
 - » One MPPT channel only connect to one string of PV modules. PV modules in the same string must be of the same brand and be tilted identically.
 - » The positive or negative pole of the PV modules should not be grounded.
 - » The positive cables of the PV modules must be connected to positive DC connectors. The negative cables of the PV modules must be connected to negative DC connectors.

NOTICE!

- The number of PV modules varies with the power of this series inverter. Inverters of 4 kW, 5 kW, or 6 kW can connect to two PV strings; and 8 kW, 10 kW, 12 kW, and 15 kW inverters can connect to three PV strings.
- Here only take "connecting to one PV string" as an example, to show how to wire to the PV terminal.

Wiring procedure

Step 1: Strip the insulation of the PV cables to an appropriate length.

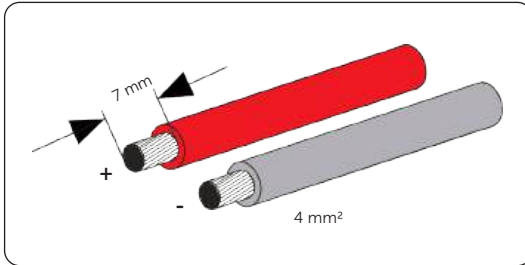

Figure 8-22 Stripping the PV cable

Step 2: Insert the stripped cables into the PV pin contacts (part C and part E). Make sure the PV cable and PV pin contact are of the same polarity.

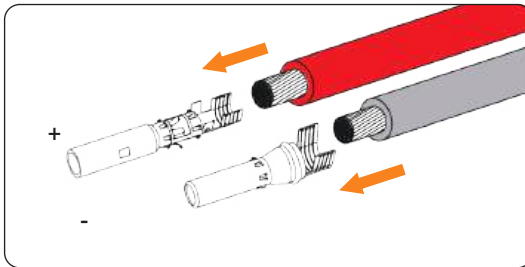

Figure 8-23 Inserting the PV pin contact

Step 3: Crimp it with the crimping tool for PV terminal. Pay attention to the crimping position.

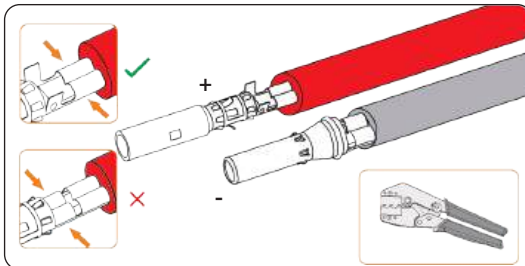

Figure 8-24 Crimping the terminal

Step 4: Thread the PV cables through the swivel nuts and insert them into the PV connectors (part D and part F) separately.

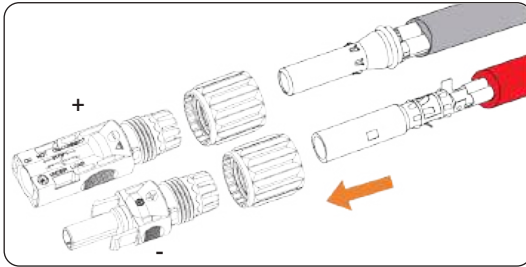

Figure 8-25 Threading the PV cable

- Step 5:** When hearing a sound of "click", gently pull the cables backward to ensure firm connection. Tighten the swivel nuts by twisting them clockwise. Verify that the PV connectors are of the correct polarity before connection.

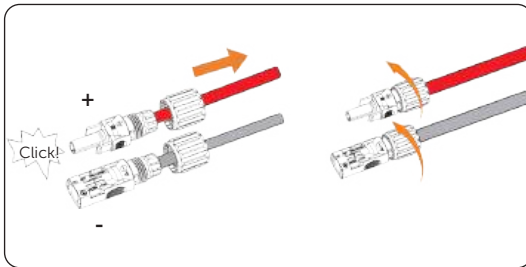

Figure 8-26 Securing the PV cable

- Step 6:** Measure the positive and negative voltage of the assembled PV connectors with a voltage measuring device which complies with the local regulation. Make sure the device operation voltage is less than 950 V.

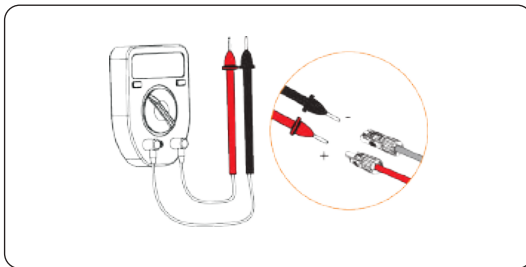

Figure 8-27 Measuring the voltage of PV connectors

NOTICE!

If the voltage reading is negative, it indicates that the polarity of the DC input is incorrect. Please check whether the wiring of the measuring device is correct or PV connectors are installed correctly.

Step 7: Remove caps on the PV terminals and connect the assembled PV connectors to the corresponding terminals. When hearing a sound of "Click", it indicates your operation is correct. The PV+ on the string side must be connected to the PV+ on the inverter side, and the PV- on the string side must be connected to the PV- on the inverter side.

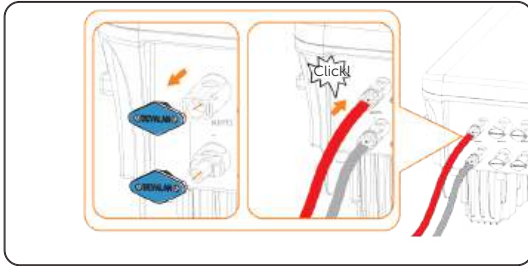

Figure 8-28 Connecting the PV cable

Step 8: If there are unused PV terminals, take caps from the terminals down and seal them with dustproof buckles.

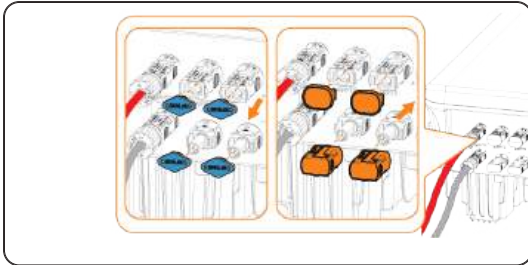

Figure 8-29 Sealing unused terminals with buckles

 **WARNING!**

According to the safety regulations, you must seal the unused terminals with dustproof buckles (parts U and V).

8.5 Battery Power Cable Connection



- Before connecting cables, make sure the breaker, power button (if any) and DC switch (if any) of the battery all are disconnected or turned off.
- Always ensure correct polarity. Never reverse the polarity of the battery cables as this will result in inverter damage.

NOTICE!

The power cable of battery is in the battery accessory pack. NOT in the scope of inverter's delivery.

Requirements for battery connection

- Battery
 - » SolaX lithium-ion battery.
 - » The inverter is equipped with two independent battery terminals, allowing for connection to two separate battery clusters at most. If two terminals are used for two battery clusters, the maximum charge/discharge current for either of the two terminals is 25 A. If only one terminal is used for one battery cluster, the maximum charge/discharge current for the terminal is 30 A.
 - » Make sure the input voltage of each BAT terminal is between 130 and 800 V.
- Micro circuit breaker (MCB)
 - » If the battery is integrated with a readily accessible DC breaker, no additional DC breaker is required. If local regulations mandate the use of a DC MCB between the battery and the inverter, install a non-polar DC MCB.
 - » The nominal voltage of DC MCB should be larger than the maximum voltage of battery.
 - » For requirements on the current of MCB, refer to the related documentation. The following displays the maximum current of each battery system that fits this inverter:

Battery system	Max charge/discharge current
T-BAT-SYS-HV-S25	45 A
T-BAT-SYS-HV-S36	50 A
T-BAT-SYS-HV-3.0	30 A
T-BAT-SYS-HV-S50E-D	50 A
T-BAT-SYS-HV-S51	70 A
T-BAT-SYS-HV-5.8	35 A

- Battery configuration

Battery system	Configuration
T-BAT-SYS-HV-3.0	2-4 battery modules for each battery terminal
T-BAT-SYS-HV-5.8 (T58 & T58 V2)	
T-BAT-SYS-HV-S50E-D	2-6 battery modules for each battery terminal
T-BAT-SYS-HV-5.8 (T58 V3)	
T-BAT-SYS-HV-S25	3-13 battery modules for each battery terminal
T-BAT-SYS-HV-S36	
T-BAT-SYS-HV-S51	
T-BAT-SYS-HV-S51	

Wiring procedure

Step 1: Strip the insulation of the battery power cable to an appropriate length.

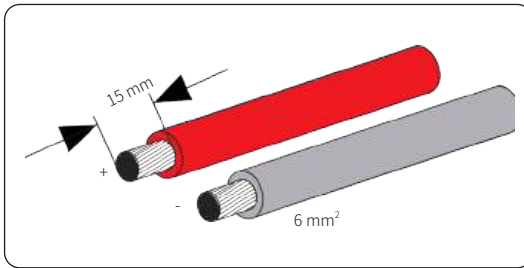

Figure 8-30 Stripping the battery cable

Step 2: Take out positive and negative battery connectors (part G and part H) from the accessory pack. Open the spring in the connector (as shown in the following picture). Insert the stripped positive and negative cables into the positive and negative connectors, until you see the cable in the connector.

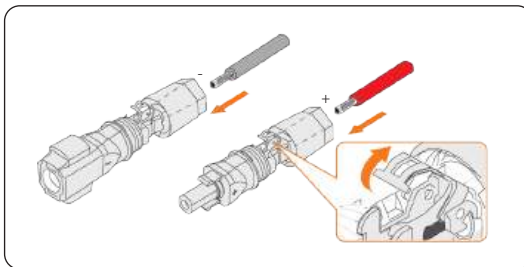

Figure 8-31 Inserting the cable into the battery connector

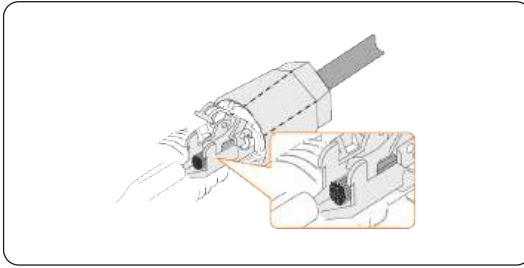

Figure 8-32 Threading until you see the cable

Step 3: Press the spring down until you hear a slight sound of "click", which indicates that the spring is closed successfully.

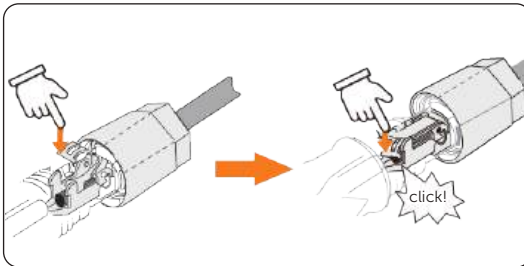

Figure 8-33 Closing the spring

Step 4: Move up the lower end of the connector and tighten the lower and upper ends together with a 15-mm open-ended wrench.

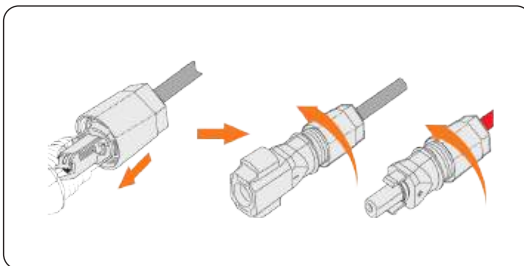

Figure 8-34 Tightening the connector

Step 5: Remove the caps on the battery terminal and connect the assembled battery connectors to the corresponding terminals. A sound of "click" indicates that you connect it successfully.

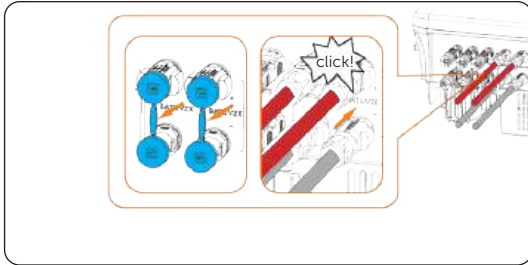

Figure 8-35 Connecting the battery connector

 **WARNING!**

Keep the terminal caps in a proper place after connecting battery power cables to the inverter. Reinstall the caps immediately after removing the connectors from the terminals.

8.6 COM 1 Communication Connection

Terminal COM 1 includes six sub-terminals: METER/CT, RS485, BMS 1, BMS 2, PARA 1 and PARA 2. Among them,

- sub-terminal METER/CT is used for connecting a meter or CT;
- sub-terminal RS485 is used for connecting an external device, such as computer;
- sub-terminals BMS 1 and BMS 2 are used for connecting batteries; and
- sub-terminals PARA 1 and PARA 2 are used for connecting other inverters in parallel.

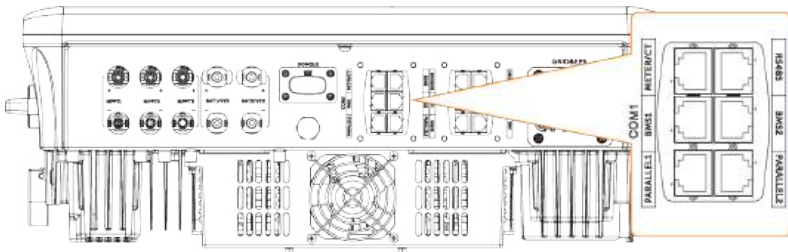

Figure 8-36 Overall layout of terminal COM 1

NOTICE!

Please make an overall planning for wiring, because cables connecting to the sub-terminals share the same connector. That is, if you need to connect to multiple sub-terminals, do not tighten the connector until all required cables go through the connector.

8.6.1 Meter/CT Connection

This section only introduces wiring of the CT/Meter terminal of the inverter. For wiring procedures of the CT and meter side, refer to “15.7 CT/Meter Connection Scenarios”.

CAUTION!

- The inverter will shut down and prompt a **Meter Fault** alarm if a meter/CT is connected to inverter improperly.
- Meters and CTs to be connected to the inverter must be authorized by SolaX. Otherwise, they might be incompatible with the inverter, resulting in inverter damage and working mode malfunction. SolaX will not be responsible for the impact caused by the use of other appliances.

Meter/CT pin assignment

Table 8-5 Meter/CT pin assignment

Pin No.	Definition	Description
1	CT_R_1	
2	CT_S_1	For CT connection
3	CT_T_1	
4	METER_485A	For meter connection
5	METER_485B	
6	CT_T_2	
7	CT_S_2	For CT connection
8	CT_R_2	

Meter/CT wiring procedure

Step 1: Pinch two sides of the dustproof cover and pull it out from the communication terminal COM1.

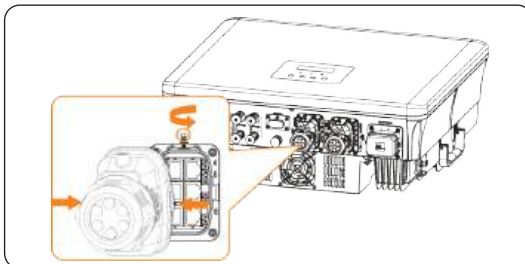

Figure 8-37 Removing the dustproof cover

Step 2: Take the communication connector (part B) from the accessory bag. Loosen the swivel nut and take out the cable support sleeve from the connector. And then remove sealing plugs from the cable support sleeve as needed.

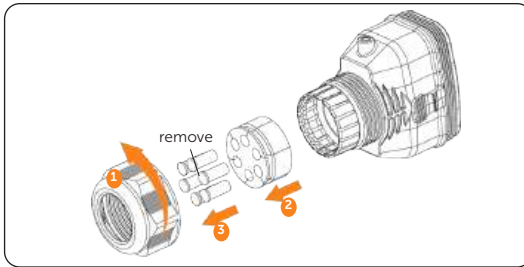

Figure 8-38 Disassembling the connector enclosure

NOTICE!

When processing the cable support sleeve, do not remove the sealing plug from the hole you are not going to use.

Step 3: Thread the cable.

- Situation 1 — Cable with the RJ45 terminal: Thread the cable through the swivel nut, cable support sleeve and connector enclosure sequentially.

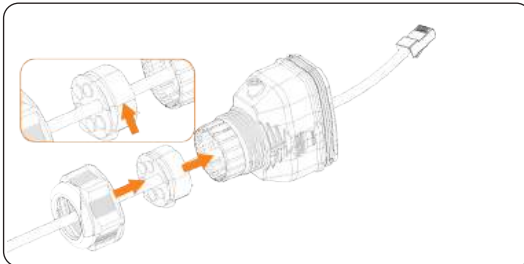

Figure 8-39 Threading the cable with the RJ45 terminal

- Situation 2 — Cable without the RJ45 terminal.
 - » Thread the cable through the swivel nut, cable support sleeve and connector enclosure sequentially. Strip the insulation of the cable to an appropriate length.

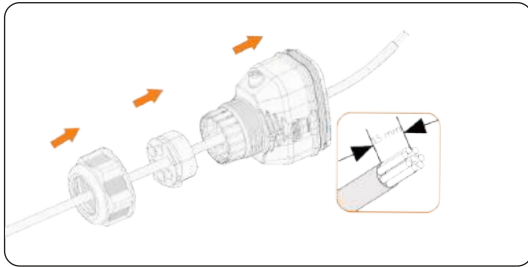

Figure 8-40 Threading the cable without the RJ45 terminal and stripping

- » Insert signal wires into the RJ45 terminal (part Q) and crimp them together with the RJ45 terminal crimping tool. Before connecting to the inverter, test the crimped cable with a network cable tester.

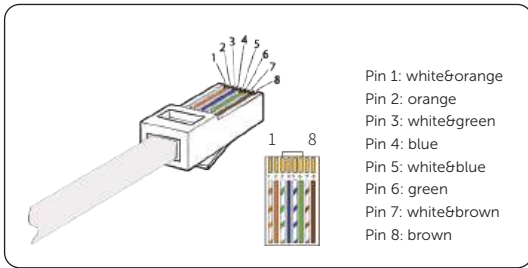

Figure 8-41 Inserting the signal wires and crimping the cable

NOTICE!

If you need to connect to other sub-terminals in the COM 1 terminal, repeat Step 3 until all required cables are threaded through the connector.

- Step 4:** Insert the RJ45 terminal into the Meter/CT sub-terminal of terminal COM 1. Secure the assembled connector for terminal COM 1.

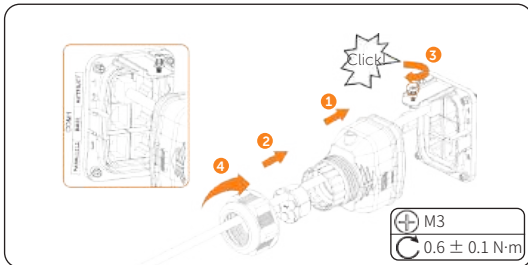

Figure 8-42 Connecting to terminal COM 1

Step 5: Connect the other end of the cable to a batch of CTs via the RJ45 connector (part R), or connect conductors 4 and 5 of the cable to terminals 24 and 25 of SolaX meter. For details about cable connection, please refer to "15.7 CT/Meter Connection Scenarios".

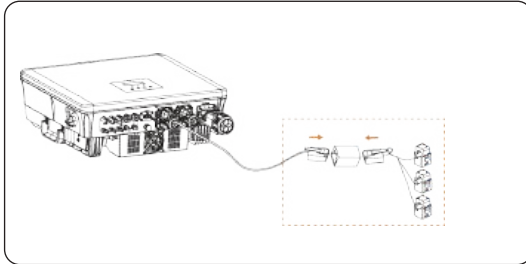

Figure 8-43 Connecting to CT

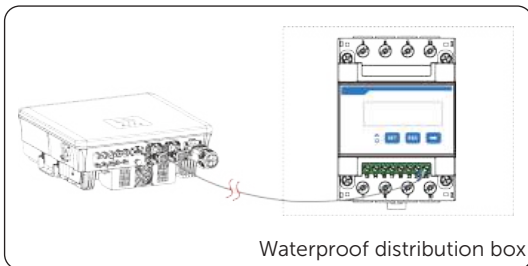

Figure 8-44 Connecting to SolaX meter

8.6.2 RS485 Communication Connection

Sub-terminal RS485 is used for connecting to the external devices. All devices supporting the Modbus protocol, such as computer, can communicate with the inverter via the terminal, to further control the inverter.

RS485 pin assignment

Table 8-6 RS485 pin assignment

Pin No.	Definition	Description
1	Not assigned	/
2	Not assigned	/
3	+12V_COM_EXT	Power supply
4	REMOTE_485A	For connecting an external device
5	REMOTE_485B	For connecting an external device
6	GND_COM	Connected to the ground
7	Not assigned	/
8	Not assigned	/

Schematic diagram of connection to external device

An external device cannot be directly connected to the RS485 sub-terminal. An RS485-to-USB converter plays the role of bridge between them.

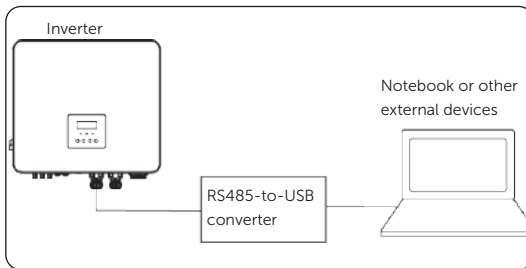

Communication connection wiring procedure

- Step 1:** Loosen the securing screw on terminal COM 1, and then hold latches on both sides of the connector enclosure to pull it out from the inverter.
- Step 2:** Loosen the swivel nut on the enclosure anticlockwise, and then remove sealing plugs from the cable support sleeve as needed. Do not remove the sealing plugs

from holes you are not going to use.

Step 3: Thread the cable through the swivel nut, cable support sleeve and connector enclosure in sequence.

Step 4: Secure the assembled connector on terminal COM 1.

- » Insert the connector enclosure into terminal COM 1 of the inverter.
- » Push the cable support sleeve into the connector enclosure.
- » Tighten the M3 screw on terminal COM 1 to fasten the connector enclosure.
Torque: 0.6 ± 0.1 N·m
- » Tighten the swivel nut clockwise, to complete connection.

NOTICE!

Steps for RS485 communication connection are similar to those for meter/CT connection, which are not described in detail herein. For more details, please refer to ["8.6.1 Meter/CT Connection"](#).

8.6.3 BMS Communication Connection

Through communication sub-terminals BMS 1 and BMS 2, the inverter can be connected to two independent battery clusters in different capacities. The model of battery modules in each cluster must be the same.

BMS pin assignment

Table 8-7 BMS1 pin assignment

Pin No.	Definition	Description
1	+3.3V_COM	Power supply
2	GND_COM	Connected to the ground
3	GND_COM	Connected to the ground
4	BMS1_CANH_CON	For battery communication (real-time data transmission)
5	BMS1_CANL_CON	For battery communication (real-time data transmission)
6	GND_COM	Connected to the ground
7	BMS1_485A_CON	For battery communication (upgrade)
8	BMS1_485B_CON	For battery communication (upgrade)

Table 8-8 BMS2 pin assignment

Pin No.	Definition	Description
1	+3.3V_COM	Power supply
2	GND_COM	Connected to the ground
3	GND_COM	Connected to the ground
4	BMS2_CANH_CON	For battery communication (real-time data transmission)
5	BMS2_CANL_CON	For battery communication (real-time data transmission)
6	GND_COM	Connected to the ground
7	BMS2_485A_CON	For battery communication (upgrade)
8	BMS2_485B_CON	For battery communication (upgrade)

BMS connection diagram

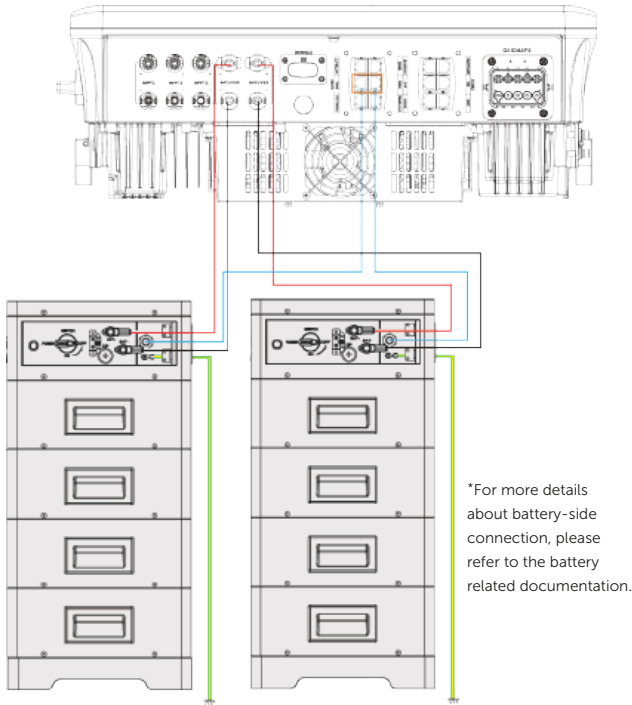

Figure 8-45 BMS connection diagram

BMS wiring procedure

- Step 1:** Loosen the securing screw on terminal COM 1, and then hold latches on both sides of the connector enclosure to pull it out from the inverter.
- Step 2:** Loosen the swivel nut on the enclosure anticlockwise, and then remove sealing plugs from the cable support sleeve as needed. Do not remove the sealing plugs from holes you are not going to use.
- Step 3:** Thread the cable through the swivel nut, cable support sleeve and connector enclosure in sequence.
- Step 4:** Secure the assembled connector on terminal COM 1.
 - » Insert the connector enclosure into terminal COM 1 of the inverter.
 - » Push the cable support sleeve into the connector enclosure.
 - » Tighten the M3 screw on terminal COM 1 to fasten the connector enclosure. Torque: 0.6 ± 0.1 N·m

- » Tighten the swivel nut clockwise, to complete connection.

NOTICE!

- The communication cable between a battery cluster and the inverter cannot exceed 3 meters.
- Steps for BMS communication connection are similar to those for meter/CT connection, which are not described in detail herein. For more details, please refer to "8.6.1 Meter/CT Connection".

8.6.4 Parallel Connection

The inverter provides the parallel connection function. In the parallel system, once an inverter is set as master, the other inverters automatically become slave inverters. For details, please refer to "15.6 Application of Parallel Function".

Parallel connection wiring procedure

- Step 1:** Loosen the securing screw on terminal COM 1, and then hold latches on both sides of the connector enclosure to pull it out from the inverter.
- Step 2:** Loosen the swivel nut on the enclosure anticlockwise, and then remove sealing plugs from the cable support sleeve as needed. Do not remove the sealing plugs from holes you are not going to use.
- Step 3:** Thread the cable through the swivel nut, cable support sleeve and connector enclosure in sequence.
- Step 4:** Secure the assembled connector on terminal COM 1.
- » Insert the connector enclosure into terminal COM 1 of the inverter.
 - » Push the cable support sleeve into the connector enclosure.
 - » Tighten the M3 screw on terminal COM 1 to fasten the connector enclosure.
Torque: 0.6 ± 0.1 N·m
 - » Tighten the swivel nut clockwise, to complete connection.

NOTICE!

Steps for parallel connection are similar to those for meter/CT connection, which are not described in detail herein. For more details, please refer to "8.6.1 Meter/CT Connection".

8.7 COM 2 Communication Connection

Terminal COM 2 includes six sub-terminals: SMART CTRL (or DATAHUB), HEATPUMP, EVC, V2X, DI/DO, and DRM. Among them,

- sub-terminal SMART CTRL (or DATAHUB) is used for connecting a datahub;
- sub-terminal HEATPUMP is used for connecting adapter box G1 or G2;
- sub-terminal EVC is used for connecting an EV-Charger;
- sub-terminal V2X is used for connecting a V2X module;
- sub-terminal DI/DO is used for connecting a generator and system switch; and
- sub-terminal DRM is used for connecting a grid scheduling device.

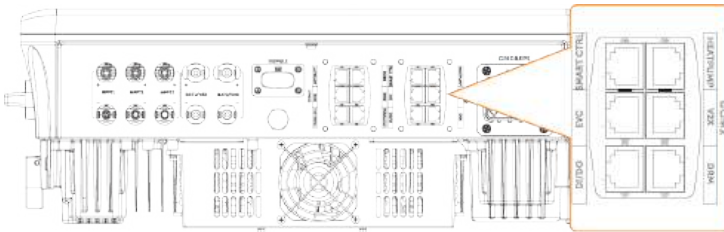

Figure 8-46 Overall layout of terminal COM2

NOTICE!

Please make an overall planning for wiring, because cables connecting to the sub-terminals share the same connector. That is, if you need to connect to multiple sub-terminals, do not tighten the connector until all required cables go through the connector.

8.7.1 Datahub, Heatpump, and EVC Communication Connection

Datahub, heatpump, and EV-Charger all can communicate with the inverter via corresponding sub-terminals in terminal COM 2. Because steps for datahub, heatpump, and EVC communication connection are similar, please refer to the same steps below. For details about application scenarios and settings for datahub, heatpump, and EV-Charger, please refer to “15.4 Application of Datahub”, “15.2 Application of Adapter Box”, and “15.3 Application of EV-Charger” respectively.

Datahub pin assignment

Table 8-9 Datahub pin assignment

Pin No.	Definition	Description
1	Not assigned	/
2	Not assigned	/
3	+12V_COM_EXT	Power supply
4	DATAHUB_485A_CON	For connecting a datahub
5	DATAHUB_485B_CON	For connecting a datahub
6	GND_COM	Connected to the ground
7	Not assigned	/
8	Not assigned	/

Datahub, heatpump, and EVC wiring procedure

Step 1: Pinch two sides of the dustproof cover and pull it out from the communication terminal COM2.

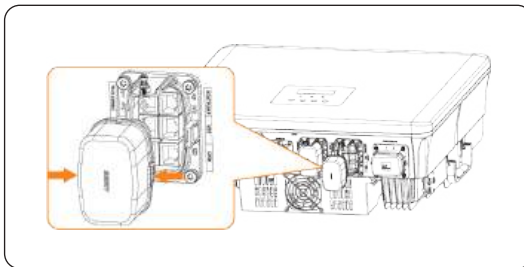

Figure 8-47 Removing the dustproof cover

Step 2: Take the communication connector (part B) from the accessory bag. Loosen the swivel nut and take out the cable support sleeve from the connector. And then remove sealing plugs from the cable support sleeve as needed.

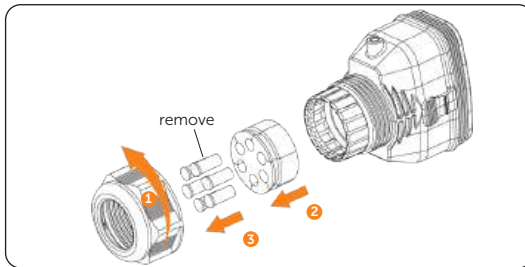

Figure 8-48 Disassembling the connector enclosure

NOTICE!

When processing the cable support sleeve, do not remove the sealing plug from the hole you are not going to use.

Step 3: Thread the cable.

- Situation 1 — Cable with the RJ45 terminal: Thread the cable through the swivel nut, cable support sleeve and connector enclosure in sequence.

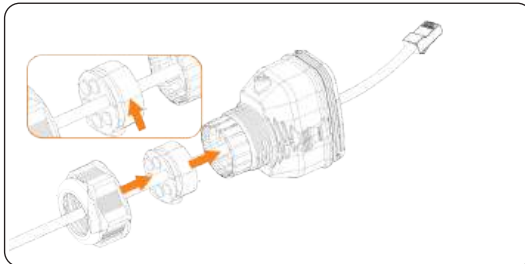

Figure 8-49 Threading the cable with the RJ45 terminal

- Situation 2 — Cable without the RJ45 terminal.
 - » Thread the cable through the swivel nut, cable support sleeve and connector enclosure in sequence. Strip the insulation of the cable to an appropriate length.

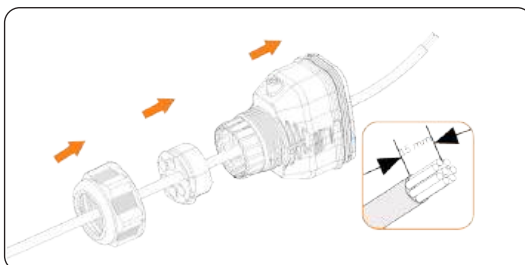

Figure 8-50 Threading the cable without the RJ45 terminal and stripping

- » Insert signal wires into the RJ45 terminal and crimp them together with the RJ45 crimping plier. Before connecting to the inverter, test the crimped cable with a network cable tester.

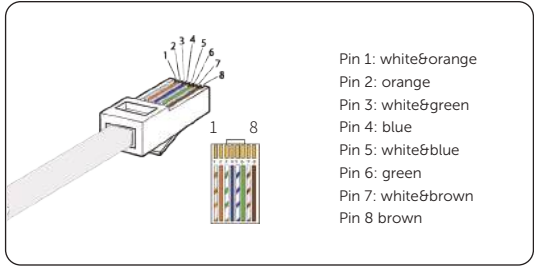

Figure 8-51 Inserting the signal wires and crimping the cable

NOTICE!

If you need to connect to other sub-terminals in the COM 2 terminal, repeat Step 3 until all required cables are threaded through the connector.

- Step 4:** Insert the RJ45 terminal into sub-terminal SMART CTRL (or DATAHUB) of terminal COM 2. Secure the assembled connector for terminal COM 2.

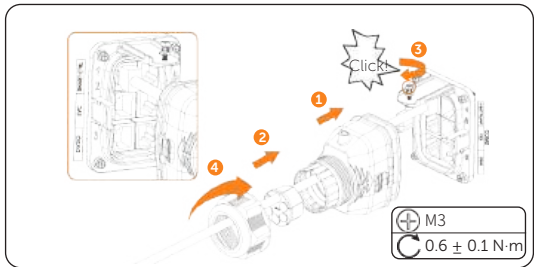

Figure 8-52 Connecting to terminal COM 2

- Step 5:** Connect the other end of the cable to a datahub, heatpump, or EVC.

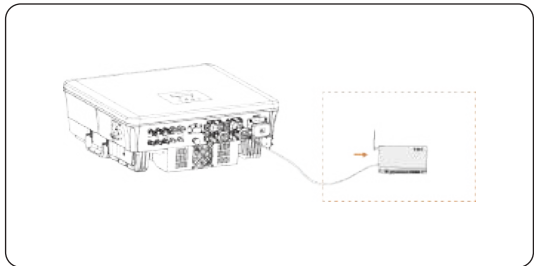

Figure 8-53 Connecting to datahub

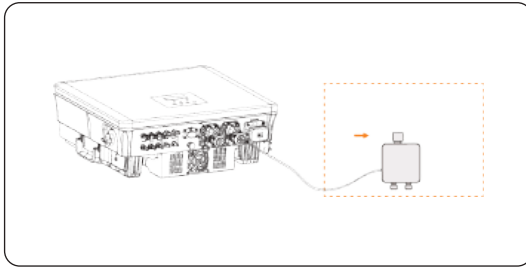

Figure 8-54 Connecting to heatpump

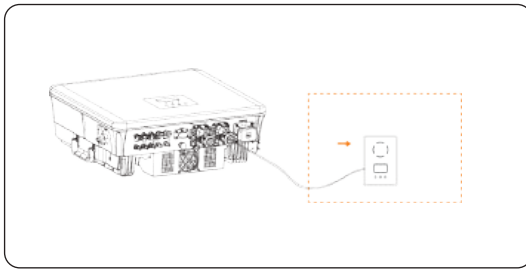

Figure 8-55 Connecting to EVC

NOTICE!

The heatpump is connected to the inverter via adapter box G1 or G2.

8.7.2 DI/DO Communication Connection

The DI/DO sub-terminal is used to connect a generator or system switch through dry contact.

To enhance safety and reduce the risk of injury, you can install the system switch in a readily accessible location through dry contact connection. In the event of an emergency, the system switch can be easily reached and pressed to promptly switch off the entire system, ensuring a swift response and preventing further harm.

For details about generator, please refer to [“15.1 Application of Generator”](#).

DI/DO pin assignment

Table 8-10 DI/DO pin assignment

Pin	Definition	Description
1	DI1_A	Dry contact for input
2	DI1_B	
3	12V_COM_EXT	
4	3.3V_COM	System off signal
5	INVERTER_OFF	
6	GND	Connected to the ground
7	DO2_A	Dry contact for output
8	DO2_B	

NOTICE!

If the device is strongly interfered by the surroundings, it is recommended to use shielding cables and ground the shielding layer of the cables through Pin 6.

System switch connection diagram

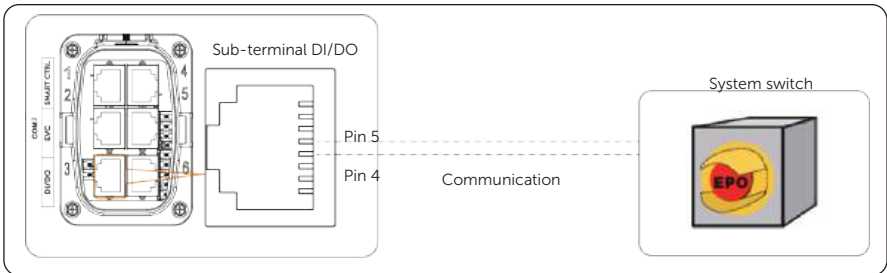

Figure 8-56 System switch connection diagram

When a system switch is pressed, **OFF MODE (INV BTN)** will be displayed on the LCD and the system will be powered off. To release the switch, press it again. You need to prepare a system switch by yourself.

DI/DO wiring procedure

- Step 1:** Loosen the securing screw on terminal COM 2, and then hold latches on both sides of the connector enclosure to pull it out from the inverter.
- Step 2:** Loosen the swivel nut on the enclosure anticlockwise, and then remove sealing plugs from the cable support sleeve as needed. Do not remove the sealing plugs from holes you are not going to use.
- Step 3:** Thread the cable through the swivel nut, cable support sleeve and connector enclosure in sequence.
- Step 4:** Secure the assembled connector on terminal COM 2.
 - » Insert the connector enclosure into terminal COM 2 of the inverter.
 - » Push the cable support sleeve into the connector enclosure.
 - » Tighten the M3 screw on terminal COM 2 to fasten the connector enclosure. Torque: 0.6 ± 0.1 N·m
 - » Tighten the swivel nut clockwise, to complete connection.

NOTICE!

Steps for DI/DO connection are similar to those for datahub, heatpump or EVC connection, which are not described in detail herein. For details, please refer to "8.7.1 Datahub, Heatpump, and EVC Communication Connection".

8.7.3 V2X Connection

The V2X sub-terminal is used for connecting to a V2X module. For more details about it, please refer to the corresponding user manual.

V2X wiring procedure

- Step 1:** Loosen the securing screw on terminal COM 2, and then hold latches on both sides of the connector enclosure to pull it out from the inverter.
- Step 2:** Loosen the swivel nut on the enclosure anticlockwise, and then remove sealing plugs from the cable support sleeve as needed. Do not remove the sealing plugs from holes you are not going to use.
- Step 3:** Thread the cable through the swivel nut, cable support sleeve and connector enclosure in sequence.
- Step 4:** Secure the assembled connector on terminal COM 2.
 - » Insert the connector enclosure into terminal COM 2 of the inverter.
 - » Push the cable support sleeve into the connector enclosure.
 - » Tighten the M3 screw on terminal COM 2 to fasten the connector enclosure. Torque: 0.6 ± 0.1 N·m
 - » Tighten the swivel nut clockwise, to complete connection.

NOTICE!

Steps for V2X connection are similar to those for datahub, heatpump or EVC connection, which are not described in detail herein. For details, please refer to “[8.7.1 Datahub, Heatpump, and EVC Communication Connection](#)”.

8.7.4 DRM Connection & TOR Connection

The DRM sub-terminal is used to connect a grid scheduling device, to comply with the grid-connected regulations in different countries. The following are pin definition and function in sub-terminal DRM:

Table 8-11 Pin assignment of terminal DRM

Pin No.	Definition	Description
1	DRM1/5	For DRM connection
2	DRM2/6	For DRM connection
3	DRM3/7	For DRM connection
4	DRM4/8	For DRM connection
5	+3.3V_COM	Power supply
6	COM/DRM0	For DRM connection; For TOR connection
7	GND_COM	Connected to the ground; For TOR connection
8	GND_COM	Connected to the ground

DRM

In Australia & New Zealand, according to AS/NZS 4777.2, the inverter needs to support the demand response mode (DRM). With a DRED (Demand Response Enabling Device), active or reactive power regulation can be realized in a timely and fast manner, and the inverter can run stably during the process of regulation.

This inverter supports three modes: DRM 0, DRM 1 and DRM 5.

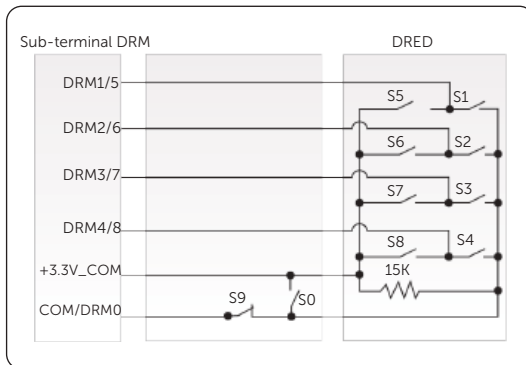

Figure 8-57 DRM connection diagram

Table 8-12 Description of DRM modes

Mode	Pin No.	Requirement
DRM 0	Pin 6	<ul style="list-style-type: none"> When S0 is closed, the inverter is switched off. When S0 is opened, the inverter restores to be connected to the grid.
DRM 1	Pin 1	<ul style="list-style-type: none"> When S1 is closed, the inverter does not input active power.
DRM 5	Pin 1	<ul style="list-style-type: none"> When S5 is closed, the inverter does not output active power.

TOR

In Austria, all grid-connected inverters must meet the requirements of TOR certification, so that the grid can control the inverter active power to be zero via a grid scheduling device.

Specifically, if the inverter does not receive the control signal, the inverter AC port exports the power normally. If the inverter receives the control signal, the inverter AC port will decrease its active power to zero in 5s.

Wiring procedure

- Step 1:** Loosen the securing screw on terminal COM 2, and then hold latches on both sides of the connector enclosure to pull it out from the inverter.
- Step 2:** Loosen the swivel nut on the enclosure anticlockwise, and then remove sealing plugs from the cable support sleeve as needed. Do not remove the sealing plugs from holes you are not going to use.
- Step 3:** Thread the cable through the swivel nut, cable support sleeve and connector enclosure in sequence.
- Step 4:** Secure the assembled connector on terminal COM 2.
- » Insert the connector enclosure into terminal COM 2 of the inverter.
 - » Push the cable support sleeve into the connector enclosure.
 - » Tighten the M3 screw on terminal COM 2 to fasten the connector enclosure. Torque: 0.6 ± 0.1 N·m
 - » Tighten the swivel nut clockwise, to complete connection.

NOTICE!

- Steps for DRM/TOR connection are similar to those for datahub, heatpump or EVC connection, which are not described in detail herein. For details, please refer to "[8.7.1 Datahub, Heatpump, and EVC Communication Connection](#)".
- After TOR wiring, you further need to enable the TOR function manually in **Setting > Advanced Settings > On-grid Settings > WLV FUN**. For details about settings, see "[Setting WLV FUN \(Applicable to Austria TOR\)](#)".

8.8 Monitoring Connection

This inverter communicates with the SolaXCloud via a dongle pocket. The dongle connects to an inverter via port **Dongle**, so that it can transmit device data to the SolaXCloud over Wi-Fi or LAN. Also with the dongle, users can monitor and manage the inverter remotely.

X3-HYB G4 PRO is equipped with dongle pocket Wi-Fi+LAN. You can select a proper communication method according to your actual situations.

Monitoring connection diagram

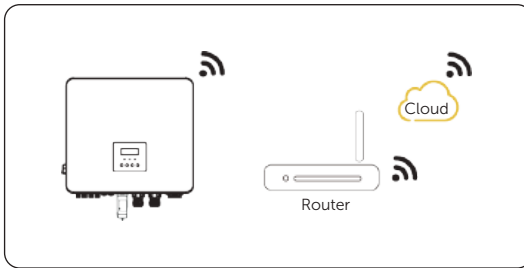

Figure 8-58 Wi-Fi mode connection diagram

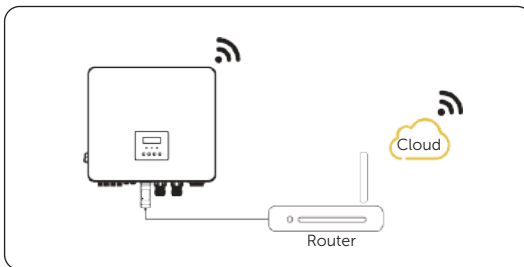

Figure 8-59 LAN mode connection diagram

Monitoring wiring procedure

Wi-Fi mode:

- a. Assemble the dongle.

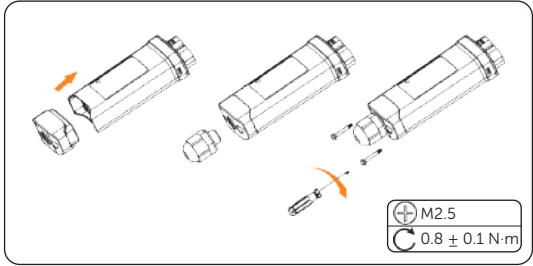

Figure 8-60 Assembling the dongle

- b. Plug the dongle into the inverter.

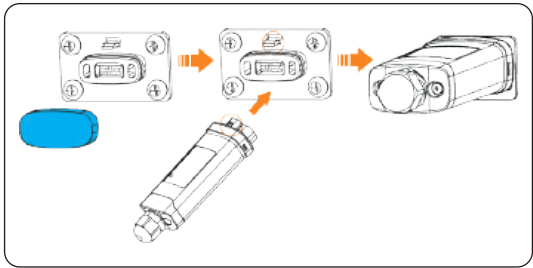

Figure 8-61 Connecting the dongle

CAUTION!

- The buckles on the inverter and dongle must be on the same side. Otherwise, the dongle may be damaged.

NOTICE!

- Keep the distance between the router and the inverter less than 100 meters. If there are walls between them, the distance must be less than 20 meters.
- If the Wi-Fi signal is not strong enough, install a Wi-Fi signal booster.
- You can configure the Wi-Fi only after the inverter is powered on. For details about Wi-Fi configuration, refer to the guide documents in the SolaXCloud App.

LAN mode:

- a. Disassemble the waterproof connector into components 1, 2, 3 and 4; Component 1 is not used. Keep it in a safe place.

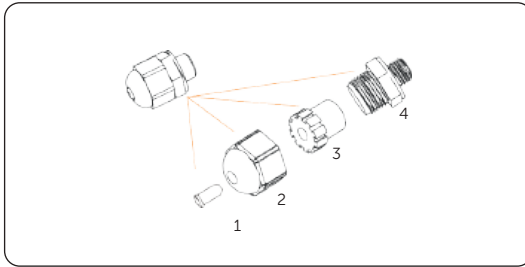

Figure 8-62 Disassembling the waterproof connector

- b. Assemble the dongle.

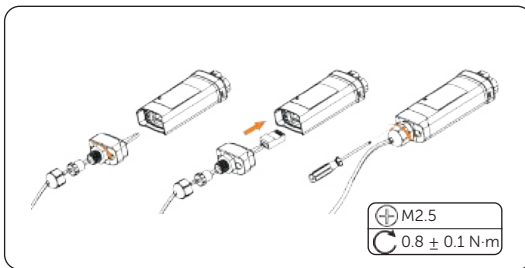

Figure 8-63 Assembling the dongle

- c. Plug the dongle into the inverter.

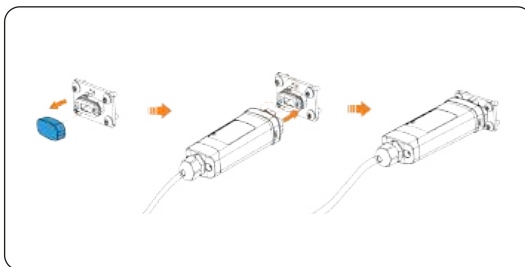

Figure 8-64 Connecting the dongle

! CAUTION!

- The buckles on the inverter and dongle must be on the same side. Otherwise, the dongle may be damaged.

9 System Commissioning

9.1 Checking before Power-on

No.	Item	Checking details
1	Installation	The inverter is installed correctly and securely. The battery is installed correctly and securely. Other devices (if any) are installed correctly and securely.
2	Wiring	All DC, AC cables and communication cables are connected correctly and securely. The meter/CT is connected correctly and securely. The ground cable is connected correctly and securely.
3	Breaker	All the DC breakers and AC breakers are disconnected.
4	Connector	The external AC and DC connectors are connected. The connector for the Grid & EPS terminal is connected correctly and securely.
5	Unused terminal	Unused terminals are covered with waterproof caps or dust-proof buckles.
6	Screw	All the screws are tightened.

9.2 Powering on the System

Step 1: Connect the DC breaker, turn on the DC switch, and check whether the LCD works normally.

- » If it works normally, press **Enter** to go to the main menu. Select **System On/Off** and set **Switch** to **On**.
- » If it works abnormally, refer to "[12.2 Troubleshooting](#)" for the solution.

Step 2: Connect the AC breaker and wait for the inverter to power on.

Step 3: Complete meter or CT settings and check their connection status. For the specific method, refer to "[Meter/CT Settings](#)" and "[15.7 CT/Meter Connection Scenarios](#)".

Step 4: Switch on the battery (refer to documentation of the battery manufacturer). Set **Forced Discharge** and **Forced Charge** by selecting **Menu>Mode Select>Manual** to verify whether the charging and discharging of battery is normal.

A distributor or installer can also check the connection status of one or all parts via one-click self check on the SolaXCloud App in the path of **More>Local>Self Check** or **Device>Device Details>Self Check**. The self check includes Meter/CT check, battery charging & discharging check, PV power generation check, off-grid check, on-grid restart check, communication status check, and fan check.

9.3 DC Switch

This series of inverters are provided with two types of DC switch:

- General type (without lock): Applicable to most countries and regions.
- Lockable type (with lock): Applicable to Australia and New Zealand only.

Operations on DC switch (general type)

- Switch on the device: Rotate the DC switch from **OFF** to **ON**.

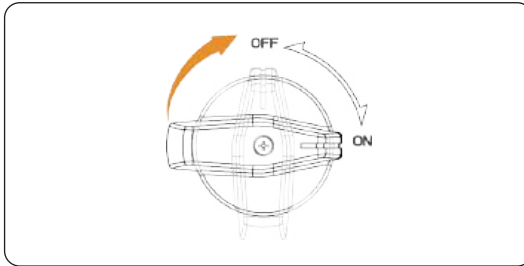

Figure 9-65 Turning on the device

- Switch off the device: Rotate the DC switch from **ON** to **OFF**.

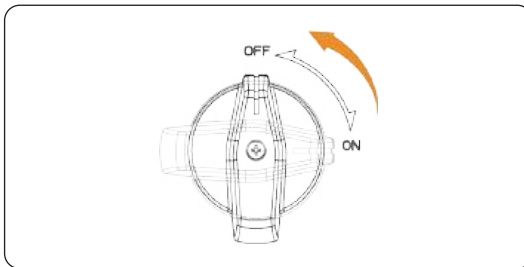

Figure 9-66 Turning off the device

Operations on DC switch (lockable type)

- Switch on the device: Rotate the DC switch from **OFF** to **ON**.

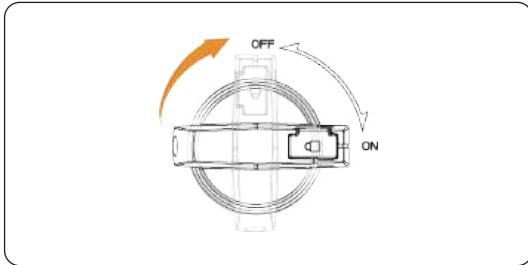

Figure 9-67 Turning on the device

- Switch off the device: Rotate the DC switch from **ON** to **OFF**.

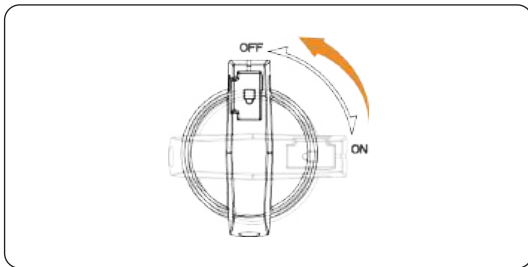

Figure 9-68 Turning off the device

- When the device is switched off, lock it:

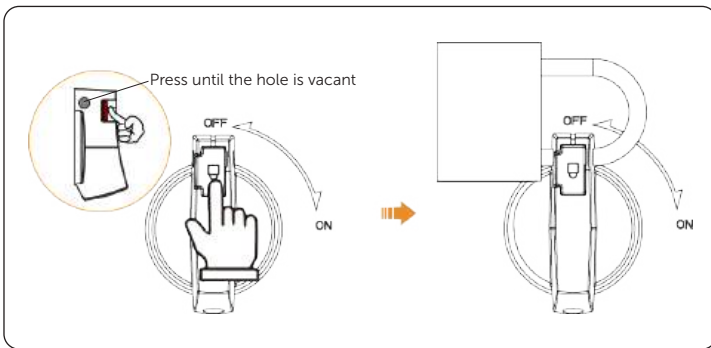

Figure 9-69 Locking the DC switch

10 Operation on LCD

10.1 Introduction of Control Panel

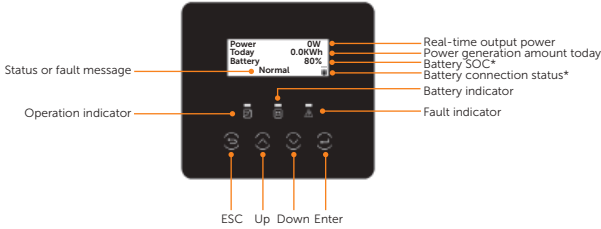

Figure 10-1 Control Panel

In normal state, the LCD will display "Power", "Power generation amount today", "Battery SOC" and "Battery connection status".

In abnormal state, the fault message and error code will be displayed. Please refer to "12.2 Troubleshooting" for corresponding solutions.

Table 10-1 Description of indicators













Item	Status	Description
 Operation indicator		Always on The inverter is in normal state.
		Flicker The inverter is in waiting or checking state.
 Fault indicator		Always on A fault occurs to the inverter.
	 Battery indicator	
		Flicker Both of the battery terminals are in idle state.

Table 10-2 Description of keys

Key	Description
 ESC	Exit from the current interface or function.
 Up	Move the cursor up or increase the value.
 Down	Move the cursor down or decrease the value.
 Enter	Confirm the current selection.

Note:

- Battery connection status: When the icon flickers, it indicates that all battery clusters communicate with the inverter abnormally.
- Battery SOC: The percentage of the remaining battery energy to the total battery capacity.

10.2 Introduction of Menu Interface

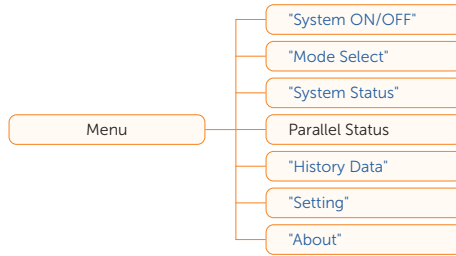

There are 7 sub-menus in the menu that can be selected for relevant setting operations.

- **System ON/OFF:** Switch on and off the inverter.
- **Mode Select:** Set the working mode for the inverter. The working modes include **Self Use Mode, Feed-in Priority, Backup Mode, Manual, Peaking Shaving Mode,** and **TOU.**

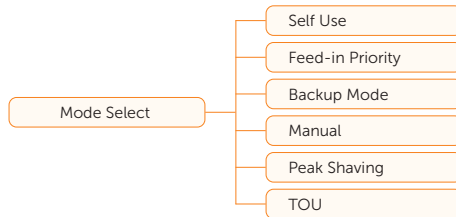

- **System Status:** Display the real-time system information, including MPPT, battery, on-grid, EPS, meter/CT and communication status.

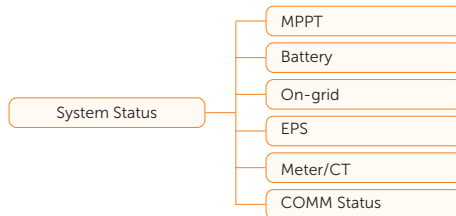

- **Parallel Status:** Display the status data of all devices at the LCD of the master inverter when multiple inverters are connected in parallel. Specifically, it shows the grid connection status of all slave inverters and the number of slave inverters connecting to the grid successfully.
 - » ○ indicates that a device is connected to the grid successfully.
 - » × indicates that a device failed to connect to the grid.

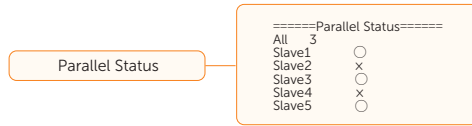

- **History Data:** Display the history data of **On-grid**, **EPS**, **E_Feedin**, **E_USERDEF** and **Error Log**.

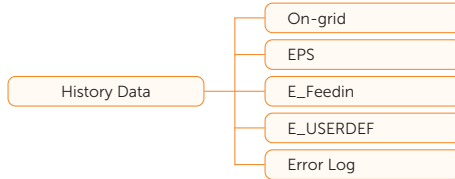

- **Settings:** Set parameters for the inverter. It includes **User Settings** and **Advanced Settings**.

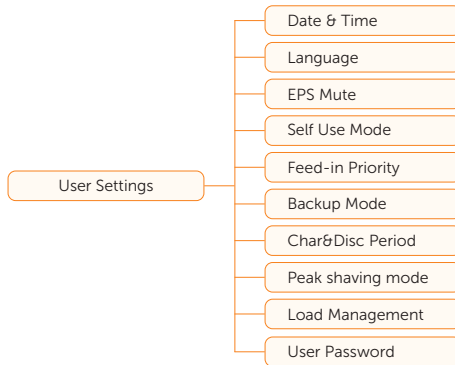

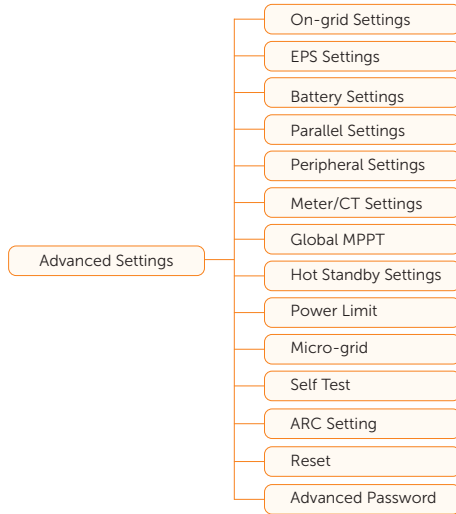

- **ARC Clear:** Used to manually clear the fifth arc fault alarm within a day.

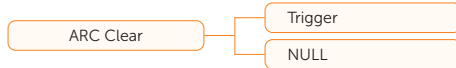

- **About:** Display the information about **Inverter**, **Battery 1**, **Battery 2** and **Internal code**.

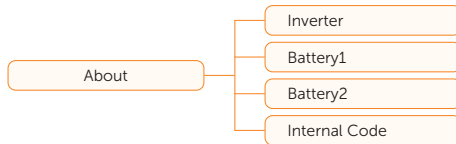

- **ARC Info:** Display the basic information of AFCI (Arc Fault Circuit Interrupter).

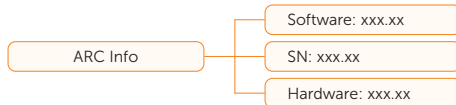

10.3 System ON/OFF

Setting path: **Menu>System ON/OFF**

Select **ON** or **OFF** to switch on and off the inverter. The switch is set to be **ON** by default. When you select **OFF**, the inverter stops running and displays **System OFF**.

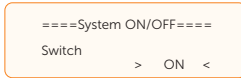

10.4 Mode Select

Selecting path: **Menu>Mode Select**

When the inverter is in on-grid state, there are 6 working modes for you to choose: Self use mode, Feed-in Priority, Backup, Peak shaving mode, TOU mode and Manual. You can choose the working modes according to your lifestyle and environment. Please refer to "2.7 Working Mode" for introduction of the modes and "10.7.1 User Settings" for specific settings of each mode.

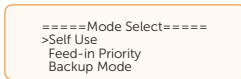

10.5 System Status

Displaying path: **Menu>System Status**

The system status includes: MPPT status, Battery status, On-grid data (about power sold to and taken from the grid), EPS data, Meter/CT, and communication status:

- **MPPT status:** This interface displays the voltage, current, and frequency of MPPT 1, MPPT 2, and MPPT 3 (if any). 4 kW, 5 kW, and 6 kW inverters can connect to 2 MPPTs at most; and 8 kW, 10 kW, 12 kW, and 15 kW inverters can connect to 3 MPPTs at most.

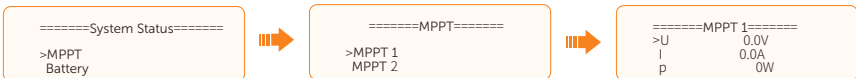

- **Battery status:** There will be information of **Battery1** and **Battery2** displayed here. It shows the status of each battery terminal, including the voltage, current, power, SOC, cell temperature and BMS connection status. Positive value means charging; Negative value means discharging.

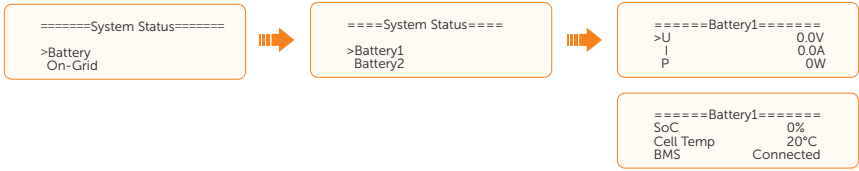

- On-grid data: It displays the voltage, current, frequency, and output power of Grid terminal when the inverter is connected to the grid. The "A", "B" and "C" in **On-grid A**, **On-grid B** and **On-grid C** refers to L1, L2 and L3 respectively. Here take **On-grid A** as an example. If the value is positive, it indicates power output. If the value is negative, it indicates power input.

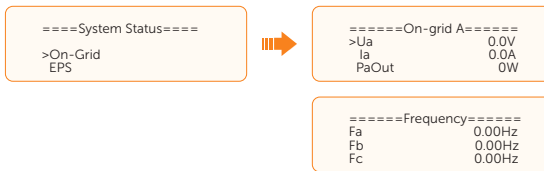

- EPS data: It shows the apparent power, voltage, current, active power and frequency of the EPS terminal when the inverter is disconnected from the grid. The "A", "B" and "C" in **EPS A**, **EPS B** and **EPS C** refers to L1, L2 and L3 respectively. The figure below displays details about **EPS A**.

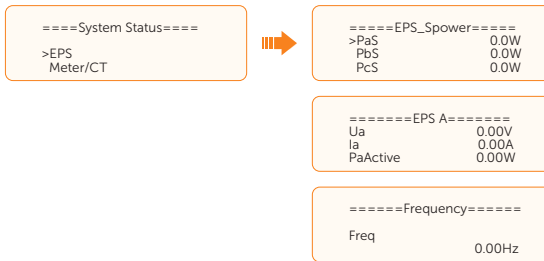

- Meter/CT: It shows the feed-in power of L1, L2 and L3 detected by the connected meter or CT. If the Pfeedin value is positive, it indicates power fed into the grid. If the Pfeedin value is negative, it indicates power taken from the grid.



- COMM Status:



10.6 History Data

Displaying path: **Menu>History Data**

After entering the **History Data** interface, the data of **On-grid**, **EPS**, **E_Feedin**, **E_USERDEF**, **Error Log** will be displayed on the LCD as follows:

- **On-grid**: A record of the output and input electric energy of the inverter today and the total (through the Grid terminal).
 - » **Output Today**: Output electric energy of the inverter today.
 - » **Output Total**: Total output electric energy since the inverter activated for the first time.
 - » **Input Today**: Input electric energy of the inverter today.
 - » **Input Total**: Total input electric energy since the inverter activated for the first time.

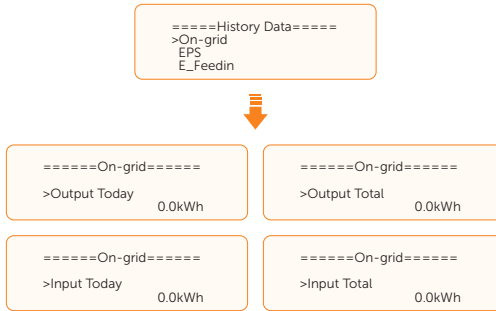

- **EPS**: The output electric energy of the inverter today and in total, when it is disconnected from the grid (through the EPS terminal).

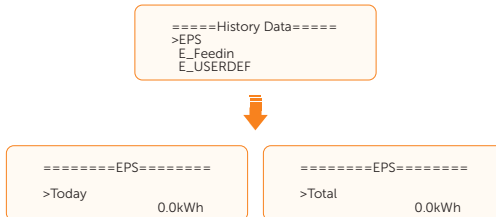

- **E_Feedin**: The total electricity fed into or taken from the grid since the inverter activated for the first time and on that day (detected by Meter/CT).
 - » **Feedin Today**: Electricity sold to grid today.
 - » **Feedin Total**: Total electricity sold to grid since the inverter activated for the first time.
 - » **Consume Today**: Electricity bought from grid today.

- » **Consume Total:** Total electricity bought from grid since the inverter activated for the first time.

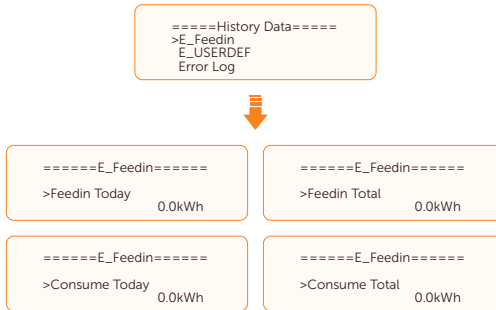

- **E_USERDEF:** The output electricity of the connected on-grid inverter today and in total (detected by Meter 2). This function is only available when meter 2 is connected.

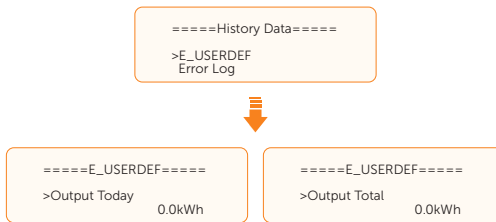

- **Error Log:** Display the latest 6 error messages. Information contains error occurrence date and time, error code and error description.



10.7 Settings

Settings includes User Settings and Advanced Settings.

10.7.1 User Settings

Setting path: **Menu>Setting>User Settings**

NOTICE!
The default password for User Settings is "0 0 0 0".

Setting Date & Time

You can set the current date and time of the installation site.

The display format is "2023-06-16 14:00", in which the first four numbers represent the year (e.g. 2000~2099); the fifth and sixth numbers represent the month (e.g. 01~12); the seventh and the eighth numbers represent the date (e.g. 01~31). The remaining numbers represent the time.



Setting Language

This inverter provides multiple languages for you to choose, such as English, Deutsch, francais, Polskie, Espanol, Português. The default language is English.



Setting EPS Mute

When the inverter is running in EPS mode, you can choose whether to turn on the buzzer.

- If yes, the buzzer mutes.
- If not, the buzzer will sound every 4s when "Battery SOC > Min EPS SOC". When "Battery SOC = Min EPS SOC", the buzzer will sound every 0.4s. This function is turned off by default.



Setting Self Use Mode

Please refer to "2.7.1 Self-use Mode" for working logic of this mode.

In this mode, you can set:

- the minimum SOC of the battery.
- whether to take power from the grid to charge the battery and the target value of battery charging.

The specific settings are as follows:

- **Min SOC:** Default: 10%; range: 10%~100%
 - » The minimum SOC of the battery. The battery will not discharge power when its remaining power reaches this value.



- **Charge from grid:**
 - » You can set whether to take power from the grid to charge the battery in the forced charging period. When **Charge from grid** is set to **Enable**, the grid power is allowed to charge the battery; when it is set to **Disable**, the grid power is not allowed to charge the battery.



- **Charge battery to:** Default: 30%; range: 10%~100%
 - » Set the target SOC to charge the battery from grid in the forced charging period (applicable only when the **Charge from grid** is enabled).
 - » You can set a target value, i.e. during the forced charging period, the inverter will use both PV & grid power to charge the battery to the target value. After the target value is reached, if the PV still has sufficient power (enough for load and there is excess power), the inverter will continue to charge the battery.

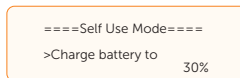

Setting Feed-in Priority

Please refer to "2.7.2 Feed-in Priority" for working logic of this mode.

In this mode, you can set the minimum battery SOC and battery charging target value.

- **Min SOC:** Default: 10%; range: 10%~100%
 - » The minimum SOC of the battery. The battery will not discharge until its SOC

decreases to this value.

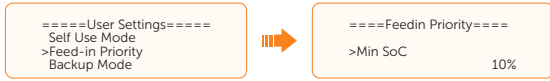

- **Charge battery to:** Default: 100%; range: 10%~100%
 - » Set the target SOC to charge the battery from grid in the forced charging period.
 - » You can set a target value, i.e. during the forced charging period, the inverter will use both PV & grid power to charge the battery to the target SOC value. After the battery SOC meets the target value, if the PV power is still sufficient, the surplus power will be fed into the grid.

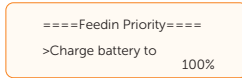

Setting Backup Mode

Please refer to "2.7.3 Backup Mode" for working logic of this mode.

- **Min SOC:** Default: 30%; range: 15%~100%
 - » The minimum SOC of the battery. The battery will not discharge power when the SOC of the battery reaches this value.

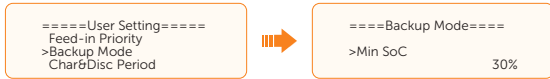

- **Charge battery to:** Default: 50%; range: 30%~100%
 - » In this mode, the "charge from grid" function is turned on by default, and customers can set the target value by themselves. That is, during the forced charging period, the inverter will use both PV & grid power to charge the battery to the target value. If the PV power is still sufficient (enough for load and there is excess power), the inverter will continue to charge the battery.

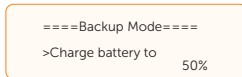

Setting Char&Disc Period

Here you can set the **Forced Charge Period** and **Allowed Discharge Period**.

If two charging and discharging periods are needed, enable the **Function Control** to activate **Char&Disc Period2**.

- **Char&Disc Period:** You can set the charge and discharge time according to your own needs. The default time axis of the system is 24h.

- » **Forced Charge Period Start Time:** Time to start charging; default: 00:00; range: 00:00~23:59
- » **Forced Charge Period End Time:** Time to stop charging; default: 00:00; range: 00:00~23:59
- » **Allowed Disc Period Start Time:** Time allowing to start discharging (The charging or discharging of the battery depends on the working mode.); default: 00:00; range: 00:00~23:59
- » **Allowed Disc Period End Time:** Time to stop discharging; default: 23:59; range: 00:00~23:59

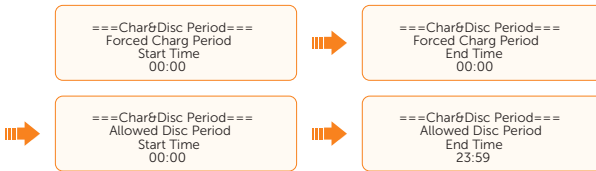

- **Char&Disc Period2:** It is closed by default. Enable it if you need to set another time period. The logic of this period is same with that of **Char&Disc Period**.

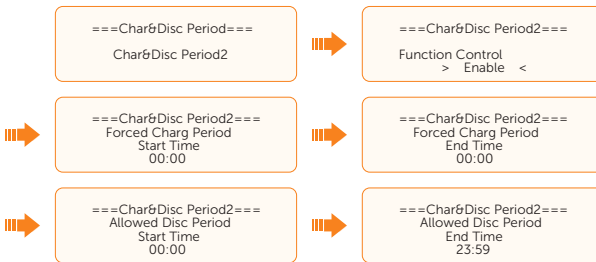

NOTICE!

- The charging and discharging period is only applicable for self use mode, feed-in priority and backup mode.
- For the period which is not set as the forced charging period or allowed discharging period, the battery can be charged but cannot discharge power.
- For the period which is set as the forced charging period and allowed discharging period at the same time, the battery will be charged forcibly.

Setting Peak Shaving Mode

Please refer to "2.7.4 Peak Shaving Mode" for the working logic of this mode.

- **PeriodA:** It can be used in a specific time period. This period allows the inverter to take energy from grid to charge battery in order to have enough backup for peak shaving. This period is the gap between ShavingEndTime2 and ShavingStartTime1.
 - » **ChargeFromGrid:** Set **ChargeFromGrid** to **Enable**, to allow the inverter to

take electrical power from grid to charge batteries. You need to further set **ChargePowerLimits** and **MAX_SOC** once **ChargeFromGrid** is enabled.

- » **ChargePowerLimits:** The largest power of taking power from the grid.
Default: 10000 W; range: 0-60000 W
- » **MAX_SOC:** The inverter will stops taking power from the grid until it charges the battery to the target SOC value. Default: 50%; range: 10%-100%

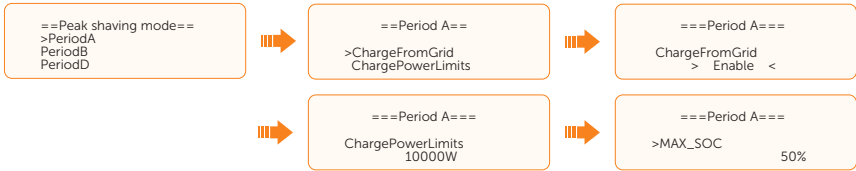

- **PeriodB:** **PeriodB** acts as peak shaving period. This period should be set to cover electricity consumption peaks. You need to set **ShavingStartTime**, **ShavingEndTime**, **PeakLimits**, **ChargeFromGrid**, and **Max_SOC**. Battery will discharge to shave consumption peak until its SOC drops to Min SOC (10% by default).
 - » **ShavingStartTime:** Default: 7:00
At this time, the battery starts to discharge to shave electricity consumption.
 - » **ShavingEndTime:** Default: 15:00
At this time, the battery stops discharging.
 - » **PeakLimits:** Default: 0 W, range: 0-60000 W
Once the grid electricity consumption reaches the limit value, the inverter will start shaving to keep the consumption lower than this value.

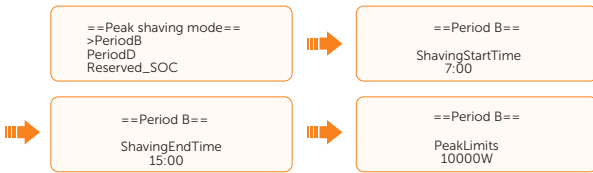

- » **ChargeFromGrid:** Set **ChargeFromGrid** to **Enable**, to allow the inverter to take electrical power from grid to charge batteries. You need to further set **ChargePowerLimits** and **MAX_SOC** once **ChargeFromGrid** is enabled.
- » **MAX_SOC:** The inverter will stops taking power from the grid until it charges the battery to the target SOC value. Default: 50%; range: 10%-100%



- **PeriodD:** Same working logic with **PeriodB**. The only difference is that its shaving start and end time are 19:00 and 23:00.

- **Reserved_SOC:** Default: 50%; range: 10%-100%
 - » It can be used in a specific time period. In this period, the inverter is not prohibited from taking grid power to charge the battery. The PV is the only way to charge the battery and it will charge the battery first. The inverter will not supply power to loads until the battery SOC is higher than the **Reserved_SOC** in order to save enough energy for later shaving period.



TOU Mode

Different from the other work modes, TOU mode is selected through the LCD but set at the SolaXCloud (App or web). In this mode, you can set different working modes for different time periods in a day. Working modes available for each time period are: Self use mode, battery off, peak shaving mode, charging mode, and discharging mode. For details about how to set the TOU Mode, refer to the document on the SolaXCloud.

Load Management

This function is ONLY applicable to adapter box G1. When adapter box G1 is connected to this inverter through dry contact, please complete the following settings in the path of **Menu>Settings>User Settings>Load Management**.

- a. Select a mode for **Load Management**. There are two modes are available to you: **Manual** and **SmartSave**.



- » **Manual:** In this mode, you can switch on/off the adapter box manually through the inverter LCD or SolaX App.
- » **SmartSave:** In this mode, you can control how and when the heat pump works intelligently by setting a series parameters.

- b. (**Manual mode**): Set **Switch** to **ON**.

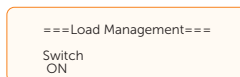

- b. (**SmartSave mode**): Set parameters for the **SmartSave** mode. In this mode, you can set **Thresholds on Feedin power**, **Thresholds off Consumption**, **Thresholds off Battery SOC**, **Minimum duration per on-signal**, **Maximum duration per day** and **Schedule** according to your actual needs.

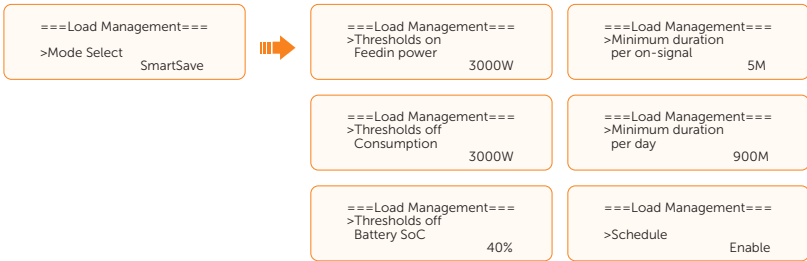

- Controlling the inverter to be on/off by threshold
 - » **Thresholds on Feedin power:** Once the feed-in power is greater than or equal to the threshold, the adapter box will be turned on and the heat pump start to work.
 - » **Thresholds off Consumption:** Once the amount of power (from the grid) you consumed is greater than or equal to the threshold, the adapter box will be turned off and the heat pump will stop working.
 - » **Thresholds off Battery SOC:** Once the battery SOC drops to the threshold, the adapter box will be turned off and the heat pump will stop working.
- Controlling the inverter to be on/off by working duration
 - » **Minimum duration per on-signal:** Once the adapter box is triggered on by a signal, it will keep working for a minimum duration.
 - » **Maximum duration per day:** Once the daily working duration of adapter box is equal to or greater than the maximum value, it will stop working.
- Controlling the inverter to be on/off by schedule

Schedule: You can set two working periods for the adapter box, so that it will work strictly according to the schedule.

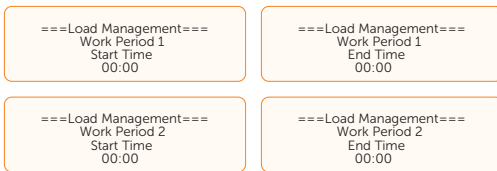

NOTICE!

In SmartSave mode, multiple settings may coexist but the execution priority for them is: **Minimum/Maximum duration > Schedule >Thresholds on/off.**

Setting User Password

The default password is "0 0 0 0". You can re-set the password here.

10.7.2 Advanced Settings

Setting path: **Menu>Setting>Advanced Settings**

NOTICE!

All the adjustable parameters including safety code, grid parameter, export control, etc. can be modified under the permissions of installer password. Unauthorized use of the installer password by unauthorized persons can lead to incorrect parameters being input, resulting in power generation loss or violation of local regulation. Get the installer password from the dealer and never open the password to unauthorized person.

On-grid Settings

Setting Safety Code

NOTICE!

- The inverter cannot be connected to the grid before the safety code is correctly set. If there is any problem about the safety code of where the inverter installed, please consult your dealer or SolaX service for details.
- The setting varies with different safety codes.

Here you can set the safety code according to different countries and grid-tied standards. In addition, the inverter has an **User Defined** option which allows you to customize relevant parameters with a wider range.

The content displayed by the LCD is subject to the actual situations.

Table 10-3 Safety code

Safety code	Country
TOR	Austria
G99	United Kingdom
TR	Denmark
EN50549-EE	Estonia
EN50549-SE	Sweden
EN50549-HU	Hungary
AS 4777.2	Australia
CEI0-21	Italy
C10/26	Belgium

Operation on LCD

Safety code	Country
G100 NI	Northern Ireland
VDE4105	Germany
PEA	Thailand

For Australia, select Australia Region A / B / C in compliance with AS/NZS 4777.2. Only after the safety code setting is completed, some designated parameters in the inverter system will take effect according to the corresponding safety regulations.

Table 10-4 Region settings

Region	Australia A	Australia B	Australia C	New Zealand	
Standard Code Name	AS4777_2020_A	AS4777_2020_B	AS4777_2020_C	New Zealand	Setting Range
OV-G-V	265 V	265 V	265 V	265 V	230-300 V
OV-GV1-T	1.5 s	1.5 s	1.5 s	1.5 s	
OV-G-V2	275 V	275 V	275 V	275 V	230-300 V
OV-GV2-T	0.1 s	0.1 s	0.1 s	0.1 s	
UN-G-V1	180 V	180 V	180 V	180 V	40-230 V
UNGV1-T	10 s	10 s	10 s	10 s	
UN-G-V2	70 V	70 V	70 V	70 V	40-230 V
UNGV2-T	1.5 s	1.5 s	1.5 s	1.5 s	
OV-G-F1	52 Hz	52 Hz	55 Hz	55 Hz	50-55 Hz
OVGF1-T	0.1 s	0.1 s	0.1 s	0.1 s	
OV-G-F2	52 Hz	52 Hz	55 Hz	55 Hz	50-55 Hz
OVGF2-T	0.1 s	0.1 s	0.1 s	0.1 s	
UN-G-F1	47 Hz	47 Hz	45 Hz	45 Hz	40-50 Hz
UNGF1-T	1.5 s	1.5 s	5 s	1.5 s	
UN-G-F2	47 Hz	47 Hz	45 Hz	45 Hz	45-50 Hz
UNGF2-T	1.5 s	1.5 s	5 s	1.5 s	
Startup-T	60 s	60 s	60 s	60 s	15-1000 s
Restore-T	60 s	60 s	60 s	60 s	15-600 s
Recover-VH	253 V	253 V	253 V	253 V	

Region	Australia A	Australia B	Australia C	New Zealand	
Standard Code Name	AS4777_2020_A	AS4777_2020_B	AS4777_2020_C	New Zealand	Setting Range
Recover-VL	205 V	205 V	205 V	198 V	
Recover-FH	50.15 Hz	50.15 Hz	50.15 Hz	50.15 Hz	
Recover-FL	47.5 Hz	47.5 Hz	47.5 Hz	47.5 Hz	
Start-VH	253 V	253 V	253 V	253 V	
Start-VL	205 V	205 V	205 V	198 V	
Start-FH	50.15 Hz	50.15 Hz	50.15 Hz	50.15 Hz	
Start-FL	47.5 Hz	47.5 Hz	47.5 Hz	47.5 Hz	

Setting Main Breaker Limit

Due to power limit, the current of Meter or CT must be set according to the utility's requirements. Failure to set it may cause a circuit breaker fault of the main switchboard, thereby affecting charging and discharging of a battery.

The default value is 250 A, range: 1-250 A

```

==Main Breaker Limit==
>Current          250 A

```

Setting Export Control

This function allows the inverter to control the output power to the grid. The setting range for **User Value** is 0-300000. If you do not want to feed power to the grid, set **User Value** to 0.

```

====Export Control====
User Value
                    300000W

```

NOTICE!

Under Safety Code AS4777.2, **Export Control** is in the path of **Advanced Settings>On-grid Settings>AS4777 Setting**. You can set the **Soft Limit** and **Hard Limit** of **Export Control** to control the power output to grid. Please refer to "[Setting AS4777](#)" for details.

Setting Phase Unbalanced

This function controls distribution of AC output power. By default, the function is disabled.

- **Enable:** Each phase of power will be independently output according to the corresponding load connected with each phase.

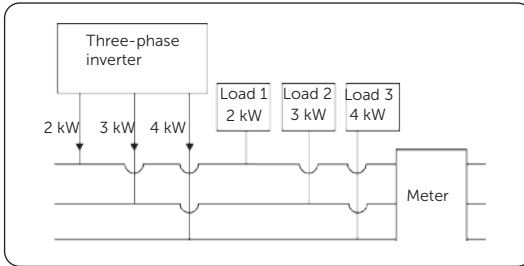

Figure 10-2 Phase Unbalanced enabled

- **Disable:** Three-phase power balanced output, with equal power in each phase. The total power output is determined by the total load power of the three phases.

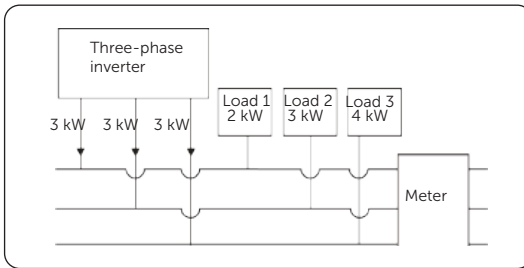
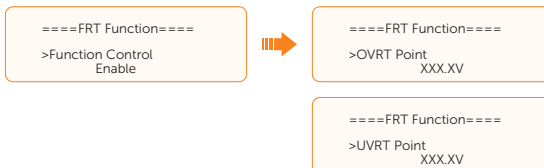

Figure 10-3 Phase Unbalanced disabled

Setting FRT function

FRT (Fault Ride Through) consists of OVRT (Over Voltage Ride Through) and UVRT (Under Voltage Ride Through). With the FRT function, the inverter can run constantly without disconnecting from the grid when a fault occurs.

- **Enable:** Enable the FRT function.
- **OVRT Point:** The value for high voltage ride through. Default value: 276.0 V. Settable range: 110.0-300.0 V.
- **UVRT Point:** The value for low voltage ride through. Default value: 115.0 V. Settable range: 4.0-300.0 V.



Setting DRM Function (Applicable to AS/NZS 4777.2)

DRM (Demand Response Management) is a demand response method required by the AS/NZS 4777.2 standard and is only applicable to Australia and New Zealand.

The function is enabled by default.

```
====DRM Function====
>Function Select
  Enable
```

Setting WLV FUN (Applicable to Austria TOR)

This function is available in Austria only. To comply with the TOR certification, you must enable this function, so that the grid can control the active power of the grid-connected inverter to be zero.

The function is disabled by default.

```
====WLV FUN====
>Function Select
  Enable
```

Setting Grid Parameters

The default value is the specified value under the current safety regulations. The content will be displayed according to the requirements of the local laws and regulations. The content displayed at the LCD is subject to the actual situations.

```
====Grid Parameters====
>Over Volt_L1
  Under Volt_L1
  Over Freq_L1
```

The following table provides you the setting range for each parameter:

Table 10-5 Setting range for parameters

Item	Setting range
Over Volt_L1	110.0-300.0 V
Under Volt_L1	8.0-230.0 V
Over Freq_L1	50.00-70.00 Hz
Under Freq_L1	40.00-60.00 Hz
Over Volt_10min	110.0-300.0 V
Over Volt_L2	110.0-312.0 V
Under Volt_L2	2.0-230.0 V
Over Freq_L2	50.00-70.00 Hz

Operation on LCD

Item	Setting range
Under Freq_L2	40.00-60.00 Hz
OvpTime_L1	
UvpTime_L1	
OfpTime_L1	0-100.00s
UfpTime_L1	
OvpTime_L2	
UvpTime_L2	
OfpTime_L2	0-20.00s
UfpTime_L2	
ReconnectionTime	
ConnectionTime	1-1000s
Connect Slope	
Reconnect Slope	1.00-600.00%
	Lower Frequency: 40.00-50.00 Hz
	Upper Frequency: 50.00-55.00 Hz
Connection/Reconnection	Lower Voltage: 9.0-230.0 V
	Upper Voltage: 11.0-300.0 V
	Observation Time: 10-600s
	Power Gradient: 1.00-600.00%

Setting OFPL

When the output frequency of an inverter exceeds the specified maximum value, the inverter will automatically lower the output frequency, to avoid damages to the device and occurrence of accidents.

OFPL (Over Frequency Power Limit) is lowering the output frequency of an inverter, to control the output power. The following are parameter related to the OFPL. The setting items may vary with the local safety regulations and requirements. The displayed content is subject to the actual situations.

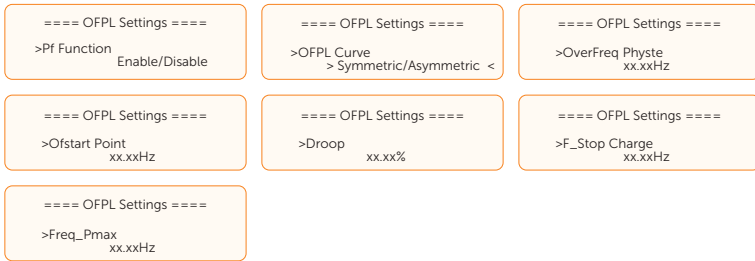

Table 10-7 Setting range for parameters

Item	Setting range
Over Freq Physte	50.00-52.00 Hz
Ofstart Point	50.00-52.00 Hz
Droop	2.0-12.0%
Delay time	0-10.0s
W (Gra)	1.00-600.00
Power Delay Time	0-600s
F_stop Charge	50.00-52.00 Hz
Fre_Pmin	51.00-53.00 Hz

Setting UFPL

If the output frequency of an inverter is lower than the specified maximum value, the inverter will automatically improve the output frequency, to ensure constant output.

UFPL (Under Frequency Power Limit) is improving the output frequency of an inverter, to ensure the output power. The following are parameter related to UFPL. The setting items may vary with the local safety regulations and requirements. The content displayed is subject to the actual situations.

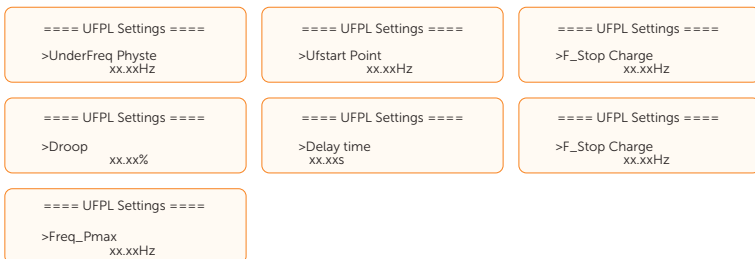

Table 10-9 Setting range for parameters

Item	Setting range
Ufstart Point	46.00-50.00 Hz
Droop	0-100.0%
Delay time	0-10.0s
F_stop Charge	48.00-50.00 Hz
Fre_Pmin	46.00-50.00 Hz

Setting Power Factor

The default value is the specified value under the current safety regulations. The content will be displayed according to the requirements of local laws and regulations. Please refer to the local grid requirements.

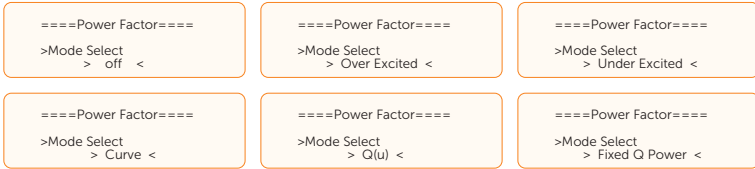

Table 10-11 Items under Power Factor

Item	Composition
Off	
Over Excited	PF Value
Under Excited	PF Value

Item	Composition	
Curve	P1 PF	
	P2 PF	
	P3 PF	
	P4 PF	
	Power 1	
	Power 2	
	Power 3	
	Power 4	
	PflockInPoint	
	PflockOutPoint	
	3Tua	
	SetQuPower1	
	SetQuPower2	
	SetQuPower3	
SetQuPower4		
Q(u)	QuRespondV1	
	QuRespondV2	
	QuRespondV3	
	QuRespondV4	
	K	
	3Tua	
	QuDelayTimer	
	QuLockEn	
	Fixed Q Power	Q Power

- Reactive power control, reactive power standard curve $\cos \varphi = f(P)$
 - » For VDE ARN 4105, the curve $\cos \varphi = f(P)$ should refer to curve A. The set default value is shown in curve A.

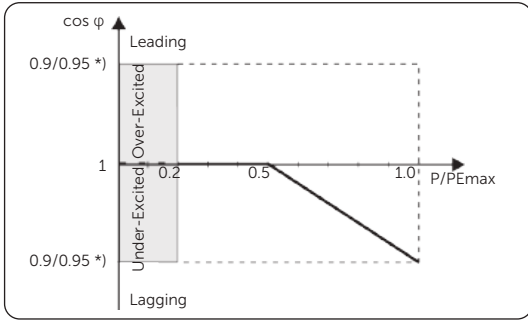

Figure 10-4 Curve A

*) If the P_{max} of the inverter ≤ 4.6 kW, the Power Factor is 0.95 at 1.0 power;
 if the P_{max} of the inverter > 4.6 kW, the Power Factor is 0.90 at 1.0 power.

- » For CEI 0-21, the default value of PFLockInPoint is 1.05. When $V_{ac} > 1.05V_n$, $P_{ac} > 0.2 P_n$, curve $\cos \phi = f(P)$ corresponds to curve B.

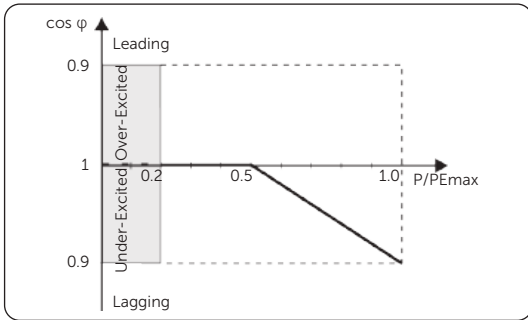

Figure 10-5 Curve B

- Reactive power control, reactive power standard curve $Q = f(V)$

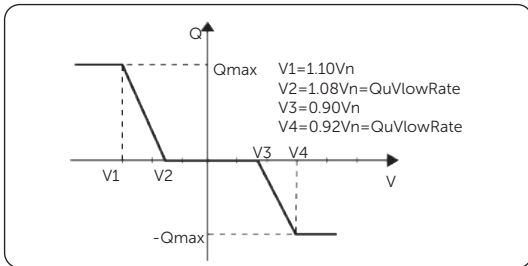

Figure 10-6 Curve $Q = f(V)$

Setting Pu Function

The Pu function is a volt-watt response mode required by certain national standards, for example AS/NZS 4777.2 and EN50459-HU. This function can control the active power of the inverter according to the grid voltage. You can set **Response Voltage**, **3Tau**, **PuPower**, **3Tau_Charge** and **Pu Type**.

The items in the **P(u) Function** interface must be adjusted in accordance with the local safety requirements and law regulations, and casual modification is prohibited. For specific settings, please refer to the local grid requirements.

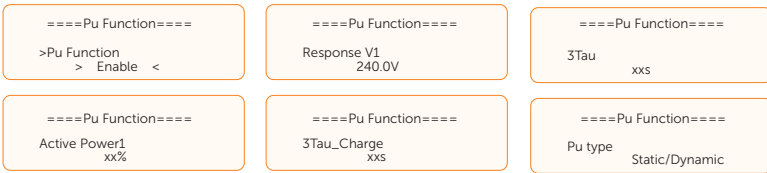

Table 10-12 Setting range for parameters

Item	Setting range
Response V1	240-2760 (precision 0.1 V)
Response V2	
Response V3	
Response V4	110-3000 (precision 0.1 V)
Active power	
3Tau	0-180s
3Tau Charger	

The following is an example curve for the volt-watt mode.

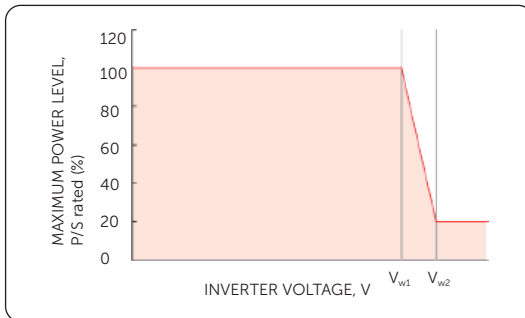

Figure 10-7 Curve for P(u)

Setting Pgrid Bias

This function is to slightly adjust the power of the inverter and the grid side when there is no output in grid-connected state. It is disabled by default.

You can do as follows:

- a. Check the **Meter/CT** value by selecting **Menu>System Status>Meter/CT**.
- b. Select **Menu>Settings>Advanced Settings>Pgrid Bias**.
 - » If the value for **Meter/CT** is negative, select **Grid** for **Pgrid Bias** to discharge power to the mains.
 - » If the value for **Meter/CT** is positive, select **INV** for **Pgrid Bias** to take power from the mains.

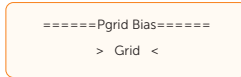

- c. Set the power for the inverter. The default value is 40W. The settable range is 1-500W.

Setting AS4777

The function of **AS4777 Setting** is only activated when the **Safety Code** is set to AS4777 and New Zealand, which is only applicable to Australia and New Zealand.

- a. Select **AS4777 Setting** from **Advanced Settings**. You will see **Export Control** (for active power output control) and **General Control** (for apparent power output control).

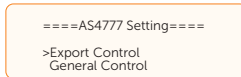

- b. Set the **Soft Limit** value and **Hard Limit** value for Export Control and General Control. The figure below will take the setup of Export Control as an example.

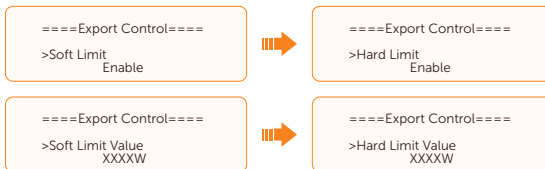

NOTICE!

- **Soft Limit:** Control the output value within the set **Soft Limit Value**.
- **Hard Limit:** If the actual output value reaches the set **Hard Limit Value**, the system will automatically disconnect from the grid and prompt error message on the LCD.

EPS Settings

Select and enter **EPS Settings** interface and set **Frequency**, **Min SOC**, **Min ESC SOC** and **Super Backup**.

- **Frequency:** Default: 50 Hz. Output frequency of EPS
- **Min SOC:** Default: 10%, range: 10%-100%
 - » If the battery SOC is lower than the **Min SOC**, the inverter will prompt **BatPowerLow** and turn off if there is no PV input.
- **Min ESC SoC:** Default: 30%, range: 15%-100%
 - » In EPS mode, the minimum SOC required for re-entry EPS mode after **BatPowerLow** prompted. When the battery SOC reaches the **Min ESC SOC** through charging from PV, the inverter will automatically enter EPS mode from EPS Waiting mode.
- **Super Backup:** This function is disabled by default. When an inverter is in EPS mode and no battery is successfully connected to the inverter, you need to enable the function.

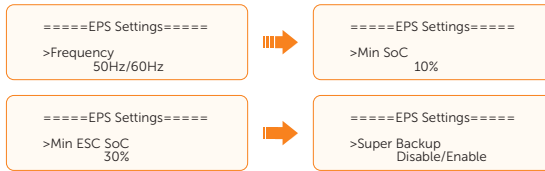

NOTICE!

In **Super Backup**, loads acquire energy from PVs, which are instable and single-phase. When a user increases or decreases the loads, the system probably reports an error of **Bus Volt Fault** or **Over Load Fault**, which is a common phenomenon and should be neglected.

- **SoC Balance:** It is used to balance battery energy for inverters connected in parallel. Specifically, once the SoC difference between two inverters is larger than the threshold for **SoC Difference**, **SoC Balance** (if enabled) will be activated to balance their SoCs in ways such as lower/increase output power and adjust the battery charge & discharge amount. But the difference between the two inverters' output power cannot be larger than the threshold for **Power Difference**.

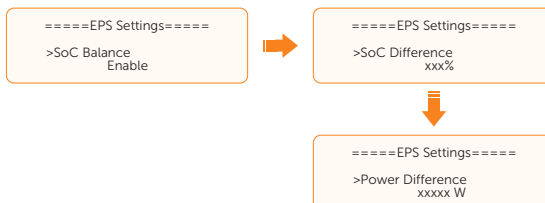

Battery Settings

Setting Charge

The inverter is compatible with lithium-ion battery. You can set the charge & discharge parameters of battery.

- **Max Charge:** Maximum charging current of battery
- **Max Discharge:** Maximum discharging current of battery
- **Charger upper limit:** The maximum charging limit. Default: 100%, range: 10%-100%.

```
====Charger====  
>Max Charge  
Current  
60A
```

```
====Charger====  
>Max DisCharge  
Current  
60A
```

```
====Charger====  
>Charger upper limit  
60%
```

Setting Battery Heating

This function is disabled by default and is only valid when the battery has the heating function. When **Battery Heating** is enabled, you need to further set the heating period.

- a. Enable the **Battery Heating** function.

```
====Battery Heating====  
>Function Select  
> Enable <
```

- b. Set the heating start time and end time for the battery. Two heating periods can be set at most.

```
====Battery Heating====  
>Heating Period 1  
Start Time  
00:00
```

```
====Battery Heating====  
>Heating Period 1  
End Time  
00:00
```

```
====Battery Heating====  
>Heating Period 2  
Start Time  
00:00
```

```
====Battery Heating====  
>Heating Period 2  
Start Time  
00:00
```

NOTICE!

If the ambient temperature is extremely low, the battery heating function will consume a large amount of electrical energy.

Setting Battery Expansion

After adding battery modules to the existing system, you need to enable this function. It is only applicable and functional in on-grid mode. In on-grid mode, enabling this function will make the inverter to charge or discharge the battery SOC to approximately 38%. After this function has been enabled for 48 hours, it will be automatically switched to **Disable**.

```

===Battery Expansion===
Function Control
> Enable <

```

Battery Discharge to EVC

When the inverter connects to an EV Charger which needs to be charged by the battery, set as follows:

- Select **Menu>Settings>Advanced Settings>Battery Settings>Bat Dchg to EVC**.
- Set **Function Control** to **Enable**. By default, the function is disabled.

```

=====Bat Dchg to EVC=====
>Function Control
> Enable <

```

Battery Discharge to HP (ADbox)

When the inverter connects to an adapter box for heat pump which needs to be charged by the battery, set as follows:

- Select **Menu>Settings>Advanced Settings>Battery Settings>BatDischgHP(ADbox)**.
- Set **Function Control** to **Enable**. By default, this function is disabled.

```

=====BatDischgHP(ADbox)=====
>Function Control
> Enable <

```

Parallel Settings

If multiple inverters are connected in parallel, you can set the master and slave inverters as follows:

- Switch on all inverters. Select an inverter and connect a meter to the inverter. Enter the LCD of the inverter and select **Menu>Settings>Advanced Settings>Parallel Settings**. Set the inverter as **Master** and set **Resistance Switch** to **ON**. Then the other inverters will automatically become slave inverters.



- Find the last slave inverter in the parallel system and set **Resistance Switch** to **ON**.

```

=====Parallel Settings=====
>Resistance Switch ON

```

NOTICE!

For details about parallel connection, refer to “15.6 Application of Parallel Function”.

Peripheral Settings

Setting External Generator

There are two methods for switching on/off the external generator: ATS and dry contact. You can refer to the corresponding settings according to the method you selected.

- ATS control
 - a. Select **Menu>Settings>Advanced Settings>ExternalGen>ATS Control**.

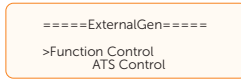

- b. Set the relative parameters as below in accordance with actual needs.
 - » **MaxChargePower:** The maximum power of generator charging battery. (0-300000 W, 5000 W by default)

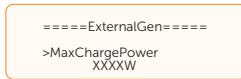

- » **Char&Disc Period:** Including **Forced Charge Period** and **Allowed Disc Period**. Two periods can be set at most.

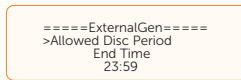
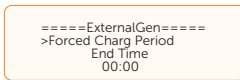
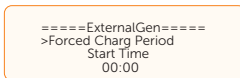

- » **Charge from Gen and Charge battery to:** It allows the battery to take power from the generator. You can set the battery target SOC (10-100%, 10% by default).

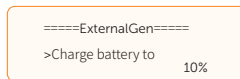
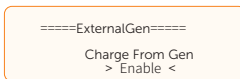

- Dry contact control
 - a. Select **Menu>Settings>Advanced Settings>ExternalGen>Dry Contact**.

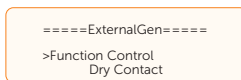

b. Set the relative parameters in accordance with actual needs.

- » **MaxChargePower:** The maximum power of generator charging battery. (0-300000 W, 5000 W by default).

```
====ExternalGen=====
>MaxChargePower
5000W
```

- » **Start Gen Method:** Two methods for you to select: **Reference SOC** and **Immediately**. **Reference SOC:** Turn on/off the generator according to the set battery SOC. **Immediately:** Turn on /off the generator immediately when the inverter disconnects from the grid.

```
====ExternalGen=====
>Start Gen Method
Reference soc
```

```
====ExternalGen=====
>Start Gen Method
Immediately
```

- » **Switch on/off SOC:** the option is activated when you select **Reference SOC** for **Start Gen Method**. The inverter will turn on the generator when the battery reaches the set **Switch on SOC** and turn it off when the battery reaches the set **Switch off SOC**.

```
====ExternalGen=====
>Switch on SoC
0%
```

```
====ExternalGen=====
>Switch off SoC
0%
```

- » **MaxRunTime:** Maximum operating time of generator. (1000 mins by default)

```
====ExternalGen=====
>MaxRunTime
1000 Min
```

- » **MinRestTime:** Minimum time interval for two consecutive starts to avoid switching on and off frequently. (60 mins by default)

```
====ExternalGen=====
>MaxRestTime
60Min
```

- » **Char&Disc Period:** Including **Forced Charg Period** and **Allowed Disc Period**. Two periods can be set at most.

```
====ExternalGen=====
>Forced Charg Period
Start Time
00:00
```

```
====ExternalGen=====
>Allowed Disc Period
Start Time
00:00
```

```
====ExternalGen=====
>Forced Charg Period
End Time
00:00
```

```
====ExternalGen=====
>Allowed Disc Period
End Time
23:59
```

- » **Allow Work:** Allowed time period for generator operating. You can set the start time and end time.

```
====ExternalGen=====
>Allow Work
Start Time
00:00
```

```
====ExternalGen=====
>Allow Work
End Time
23:59
```

- » **Charge from Gen and Charge battery to:** It allows the battery to take power from the generator. You can set the battery target SOC (10-100%, 10% by default).

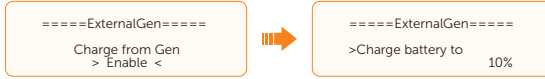

Setting External ATS

The external ATS is used for switchover of the bypass relay.

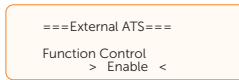

Internal485

Through the function, the inverter can communicate with other internal devices, such as EV-Charger, datahub, and adapter box.

Specific settings are as follows:

- Select **Menu>Settings>Advanced Settings>Peripheral Settings>Internal485**.
- Select the function according to your device. For details, see **NOTICE** below. Set the baud rate and communication address for your device. The baud rate is 9600 by default.

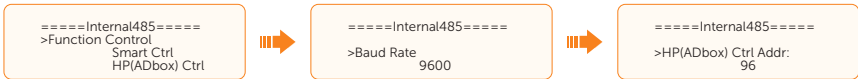

NOTICE!

- **COM485** is for the third-party device and parallel connection; **Smart Ctrl** is for datahub; **HP(ADbox) Ctrl** is for adapter box of heat pump; **EVC&HP(ADbox) Ctrl** is for EV charger and adapter box both.
- When two devices are connected to the inverter simultaneously, their baud rates and address must be the same.

- Check the connection status of the device. The setting item shown below is just an example.



Modbus

The Modbus protocol supports to communicate with an external device. For better communication, set the following:

- (Only for datahub) When multiple inverters are connected in parallel, set **Smart Ctrl Exit** to **Enable** to exit from the internal communication mode.

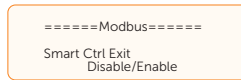

- Set the baud rate and address for an external device.



Meter/CT Settings

A CT or electricity meter needs to be connected to the inverter, to monitor the electricity usage. After connecting a meter or CT, you need to set parameters for it in the path of **Advanced Settings > Meter/CT Settings**.

- Meter setting: Select **Meter**, and set **Meter 1 Addr** to 1 and **Meter 1 Direction** to **Positive**. Before this setting, you should have set the meter address to 1 on the meter side.

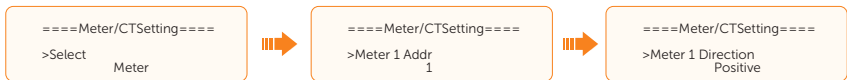

- CT setting: Select **CT**, and set **CT type** to 100 A or 200 A according to the actual situations.



This inverter further provides the check function, to ensure the correct installation and normal operation of meter/CT.

- Installation check: Select **Meter/CT Setting > Meter/CT Check**, and then enable **Installation Check**.



The system will perform installation check immediately after you enable it. If the meter or CT is connected properly, the **CT status** will display **Success**, and then automatically restore to **Disable**.

- Cyclic Check: Select **Meter/CT Setting > Meter/CT Check**, and then enable **Cyclic Check**.

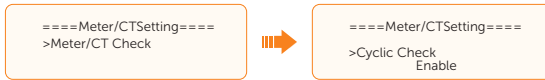

Once Cyclic Check is enabled, the system will check the meter/CT status periodically based on the defined cycle. If something is wrong with the meter/CT, it will report to the user through the LCD screen or SolaXCloud App.

For more application scenarios, refer to “15.7 CT/Meter Connection Scenarios”.

GMPPT Settings

GMPPT (Global Maximum Power Point Tracking) is to find the maximum points of PV modules and maintain them at the maximum power output. You can set the shadow tracking speed with four options, which are **Off**, **Low**, **Middle**, and **High**. This function is off by default.

- **Off**: Switch off the shadow tracking function.
- **Low**: Scan the shadow every four hours.
- **Middle**: Scan the shadow every three hours.
- **High**: Scan the shadow per hour.

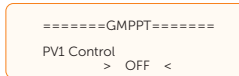

HotStandby Settings

This function is mainly to reduce the energy losses of the system when the power of load is very low.

- **Enable**: When the power of load is very low and other conditions for entering hot standby are met, the inverter will enter **HotStandby** status to reduce system losses.
- **Disabled**: Even when the power of load is very low and other conditions for entering hot standby are met, the inverter still will not enter **HotStandby** status and continue to output power to the load. It is disabled by default.

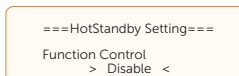

Power Limit Settings

Here you can set the rated output power by percentage.

The percentage of rated output power is used as the actual output power.

Proportion: Default: 1.00; range: 0.00-1.10

For all models of this series inverter, the proportion can be set to 0.00-1.10.

```
====Power Limit====
Proportion
  1.00
```

Micro-grid Settings

When a micro grid forms, you need to enable the function.

```
====Micro-grid====
Micro-grid
  >Disable<
```

Self Test Settings (only for CEI 0-21)

The self test function allows users to test the following items: **Full Test**, **Ovp (59.S2) test**, **Uvp (s1) test**, **Uvp (27. s2) test**, **Ovp (81> .S1) test**, **Ufp (81 <.S1) test**, **Ufp (81> .S2) test**, **Ufp (81 <.S2) test**, **Ovp10 (59. s1) test**.

In the **Self Test** interface, the user can select **All Test** or a single test item for testing. All tests take about 6 minutes. And it will display **Success**. For a single test item, it takes about a few seconds or minutes.

Before testing, make sure that the inverter is connected to the grid. Tap **Test Report** to view the test results of all items.

```
====Self Test====
>All Test
  Test Report
  Ovp (59.S2) test
```

NOTICE!

Ovp, Uvp, Ofp, and Ufp are respectively short for over voltage protection, under voltage protection, over frequency protection, and under frequency protection.

ARC Setting

This setting is only visible to the device equipped with the ARC function.

To avoid fire disasters, an AFCI is designed to detect arcing, which is caused by too high voltage or temperature, on the DC side. The AFCI meets the requirements of IEC 63027. To use the AFCI, you must complete the first two items at least.

Path: **Settings > Advanced Settings > ARC Setting**. The setting options in **ARC Setting**:

```
====ARC Setting====
>ARC Enable
  ARC Self Check
  Sensitivity setting
```

- **ARC Enable**: Used to enable or disable the arc detection function. By default, it is disabled. Once the function is enabled and the AFCI works normally, the inverter will alarm when detecting an arc.

```
=====ARC Enable=====
ARC Enable
Disable/Enable
```

- **ARC Self Check:** Used to detect whether an AFCI works normally. Only after you enable the ARC can the ARC self check be triggered.

```
=====ARC Self Check=====
ARC Self Check
Trigger/Null
```

NOTICE!

When self check is triggered, the inverter will shut down in seconds and start to check:

- If the check result is "failed", the inverter will remain closed and display **ARC SelfTest Fault code xxx** on the LCD screen.
- If the check result is "passed", the inverter will automatically restart in a while.

- **Sensitivity setting:** To ensure the precision of arc detection, you can set a sensitivity value with the help of installer. The setting password and setting range are "6868" and 0%~100%. The lower sensitivity indicates the more tests, the higher precision.

```
=====Sensitivity setting=====
>Arc sensitivity
10.0%
```

Reset

Here you can reset the error log, meter/CT, INV energy and Wi-Fi; and restore to the factory settings.

- **Reset Error Log**



- **Reset Meter/CT**



- **Reset INV Energy**



- **Reset Wi-Fi**

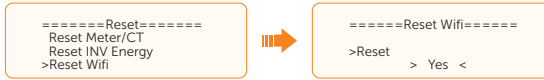

- **Factory Reset**



Advanced Password

You can re-set the advanced password here. An installer or distributor may acquire the advanced password from service@solaxpower.com.

10.8 ARC Clear

Path: **Menu > ARC Clear**

It is used to clear arc alarms. By default, the inverter automatically clears the first four alarms in 5 minutes daily. However, if the fifth alarm occurs on the day, you need to clear it manually by setting **ARC Clear** to **Trigger**.

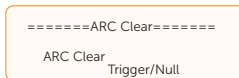

10.9 About

Displaying path: **Menu>About**

Here shows the basic information of the inverter, battery and internal code. After entering the **About** interface, you can check those information.

- Inverter
 - » Inverter SN, Register SN, ARM Version, DSP Version, On-grid Runtime, EPS Runtime
- Battery1 and Battery2
 - » BatBrand, Bat_M SN (SN of BMS), Bat_PS1 SN (SN of battery module 1), Bat_PS2 SN (SN of battery module 2), Bat_PS3 SN (SN of battery module 3), Bat_PS4 SN (SN of battery module 4), Battery M Version (software version of BMS) and Battery S version (software version of battery module).
- Internal Code
 - » Internal code of inverter, battery1 and battery2

10.10 ARC Info

Path: **Menu > ARC Info**

It provides the software version, hardware version, and SN of AFCI.

11 Operations on SolaXCloud App and Webpage

11.1 Introduction of SolaXCloud

SolaXCloud is an intelligent home energy management platform. It is integrated with energy efficiency monitoring, device management, data communication and other capabilities. While managing your home energy devices, it also helps you optimize the electricity usage efficiency and improve the power generation revenue.

11.2 Operation Guide on SolaXCloud App

11.2.1 Downloading and Installing App

Method 1: Scan the QR code below to download the SolaXCloud App.

The QR code is also available on the lower-right corner of the Web login page of SolaXCloud (www.solaxcloud.com), and the manual of the dongle.



Figure 11-1 QR code

Method 2: Search for **SolaXCloud** in the App Store or Google Play Store, and then download the app.

11.2.2 Operation on the App

After account registration and login, select **Service>Help Center** for text and video operation guidance.

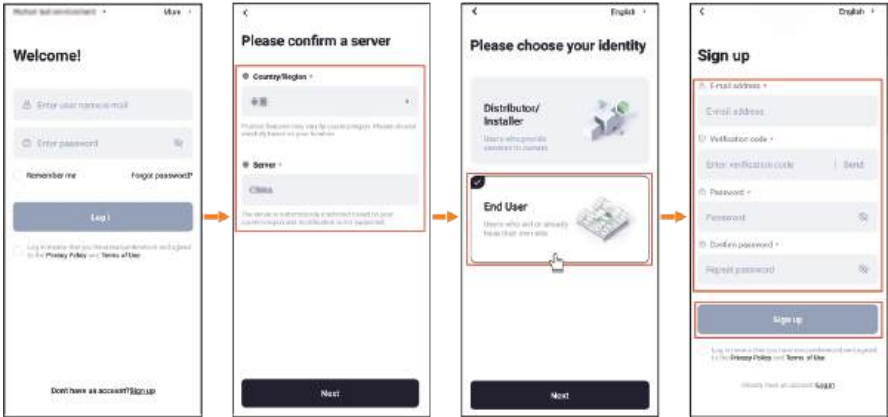

Figure 11-2 Register an account on SolaXCloud App

NOTICE!

The pages above are from SolaXCloud App V6.0.0, which may change with version upgrade. The finally displayed pages should be subject to the actual situations.

11.3 Operations on SolaXCloud Webpage

Open a browser and enter www.solaxcloud.com. Then complete registration, login, plant creation, and other operations according to the help document.

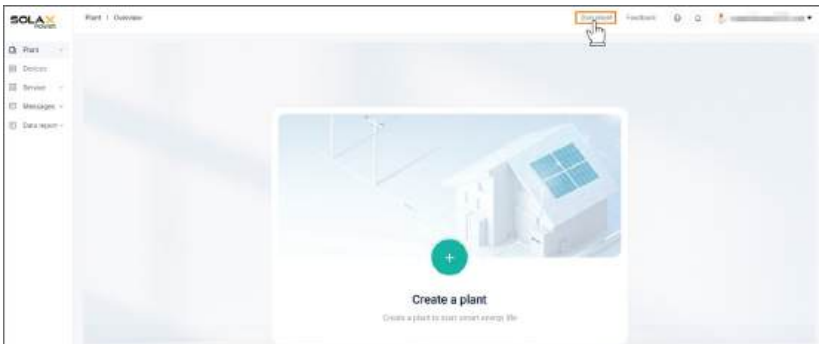

Figure 11-3 User guide on Web

12 Troubleshooting and Maintenance

12.1 Power off

- Turn off the system by **System ON/OFF** on LCD screen.
- Turn off the AC switch between the inverter and the power grid.
- Set the DC switch to **OFF**.
- Switch off the battery or the breaker, button, DC switch of the battery (refer to documentation of the battery manufacturer).



After the inverter is powered off, there may still be residual electricity and heat which may cause electric shocks and body burns. Please wear personal protective equipment (PPE) and maintain the inverter after power has been cut off for at least 5 minutes.

12.2 Troubleshooting

This section lists the possible problems with the inverter, and provides information and procedures for identifying and resolving them. In case of any errors, check for the warnings or error messages on the system control panel or App, and then refer to the suggestions below. For further assistance, contact SolaX Customer Service. Please provide the model and SN of the inverter, and be prepared to describe the system installation details.

Table 12-1 Troubleshooting list

Error Code	Fault	Diagnosis and Solutions
IE 01	TZ Protect Fault	Overcurrent fault <ul style="list-style-type: none">Wait for a while to check if it returns to normal.Disconnect PV+, PV- and batteries, reconnect.If the system is in off-grid state, check if the power of EPS loads exceeds the maximum limit of the system or exceeds the current power supply of battery.If the system fails to restore to its normal state, contact SolaX for help.
IE 02	Grid Lost Fault	Grid lost fault <ul style="list-style-type: none">Check the grid connection status.Contact SolaX for help.

Error Code	Fault	Diagnosis and Solutions
IE 03	Grid Volt Fault	<p>Power grid voltage overrun</p> <ul style="list-style-type: none"> • Wait a moment, if the utility returns to normal, the system will reconnect. • Please check if the grid voltage is within normal range. • Contact SolaX for help.
IE 04	Grid Freq Fault	<p>Grid overfrequency</p> <ul style="list-style-type: none"> • Wait a moment, if the utility returns to normal, the system reconnects. • Contact SolaX for help.
IE 05	PV Volt Fault	<p>PV overvoltage</p> <ul style="list-style-type: none"> • Check the output voltage of the PV panel. • Check if the DC switch is OFF. • Contact SolaX for help.
IE 06	Bus Volt Fault	<ul style="list-style-type: none"> • Press the ESC key to restart the inverter. • Check if the PV input open circuit voltage is in the normal range. • Check if the power of half-wave load exceeds the system limit. • Contact SolaX for help.
IE 07	Bat Volt Fault	<p>Battery voltage fault</p> <ul style="list-style-type: none"> • Check if the battery input voltage is within normal range. • Contact SolaX for help.
IE 08	AC10mins Volt	<p>Grid voltage out of range in the last 10 minutes</p> <ul style="list-style-type: none"> • The system will return to normal if the grid returns to normal. • Contact SolaX for help.
IE 09	DCI OCP Fault	<p>DCI overcurrent protection fault</p> <ul style="list-style-type: none"> • Wait for a while to check if it's back to normal. • Contact SolaX for help.
IE 10	DCV OVP Fault	<p>DCV EPS (Off-grid) overvoltage protection fault</p> <ul style="list-style-type: none"> • Wait for a while to check if it's back to normal. • Contact SolaX for help.
IE 11	SW OCP Fault	<p>Software detection of overcurrent fault</p> <ul style="list-style-type: none"> • Wait for a while to check if it's back to normal. • Shut down photovoltaic, battery and grid connections. • Contact SolaX for help.

Error Code	Fault	Diagnosis and Solutions
IE 12	RC OCP Fault	Overcurrent protection fault <ul style="list-style-type: none"> • Check the impedance of DC input and AC output. • Wait for a while to check if it's back to normal. • Contact SolaX for help.
IE 13	Isolation Fault	Insulation fault <ul style="list-style-type: none"> • Please check the wire insulation for damage. • Wait for a while to check if it's back to normal. • Contact SolaX for help.
IE 14	Temp Over Fault	Temperature out of range <ul style="list-style-type: none"> • Check if the ambient temperature exceeds the limit. • Contact SolaX for help.
IE 15	Bat Con Dir Fault	Battery direction fault <ul style="list-style-type: none"> • Check if the battery cables are connected in the opposite direction. • Contact SolaX for help if it cannot return to normal.
IE 16	EPS Overload Fault	EPS (Off-grid) overload fault <ul style="list-style-type: none"> • Shutdown the high-power device and press the ESC key to restart the inverter. • Contact SolaX for help if it cannot return to normal.
IE 17	Overload Fault	On-grid mode overload fault <ul style="list-style-type: none"> • Shutdown the high-power device and press the ESC key to restart the inverter. • Contact SolaX for help if it cannot return to normal.
IE 18	BatPowerLow	Bat power low <ul style="list-style-type: none"> • Shutdown the high-power device and press the ESC key to restart the inverter. • Charge the battery to a level higher than the protection capacity or protection voltage.
IE 19	BMS Lost	Battery communication lost <ul style="list-style-type: none"> • Check that the communication cable between the battery and the inverter are properly connected. • Contact SolaX for help if it cannot return to normal.
IE 20	Fan Fault	Fan fault <ul style="list-style-type: none"> • Check for any foreign matter that may have caused the fan not to function properly. • Contact SolaX for help if it cannot return to normal.
IE 21	Low TempFault	Low temperature fault <ul style="list-style-type: none"> • Check if the ambient temperature is too low. • Contact SolaX for help if it cannot return to normal.

Error Code	Fault	Diagnosis and Solutions
IE 25	InterComFault	Internal communication fault <ul style="list-style-type: none"> Restart the inverter. Contact SolaX for help if it cannot return to normal.
IE 26	INV EEPROM	Inverter EEPROM fault <ul style="list-style-type: none"> Shut down photovoltaic, battery and grid, reconnect. Contact SolaX for help if it cannot return to normal.
IE 27	RCD Fault	Residual current device fault <ul style="list-style-type: none"> Check the impedance of DC input and AC output. Disconnect PV+, PV - and batteries, reconnect. Contact SolaX for help if it cannot return to normal.
IE 28	Grid Relay Fault	Electrical relay fault <ul style="list-style-type: none"> Disconnect PV+, PV-, grid and batteries and reconnect. Contact SolaX for help if it cannot return to normal.
IE 29	EPS(Off-grid) Relay Fault	EPS (Off-grid) relay fault <ul style="list-style-type: none"> Disconnect PV+, PV-, grid and batteries and reconnect. Contact SolaX for help if it cannot return to normal.
IE 30	PV ConnDirFault	PV direction fault <ul style="list-style-type: none"> Check if the PV input cables are connected in the opposite direction. Contact SolaX for help if it cannot return to normal.
IE 31	Battery Relay	Charge relay fault <ul style="list-style-type: none"> Press the ESC key to restart the inverter. Contact SolaX for help if it cannot return to normal.
IE 32	Earth Relay	EPS (Off-grid) earth relay fault <ul style="list-style-type: none"> Press the ESC key to restart the inverter. Contact SolaX for help if it cannot return to normal.
IE 33	ParallelFault	Parallel fault <ul style="list-style-type: none"> Check the communication and earth cable connection and matching resistor settings. Contact SolaX for help if it cannot return to normal.
IE 36	HardLimitFault	Hard Limit fault <ul style="list-style-type: none"> Check the power value set in the HardLimit setting, increase the value larger if needed. Contact SolaX for help if it cannot return to normal.
IE 37	CTMeterConFault	CT Meter Con fault <ul style="list-style-type: none"> Check if the CT or meter is well connected. Contact SolaX for help if it cannot return to normal.

Error Code	Fault	Diagnosis and Solutions
IE 40	BypassRelayFault	<p>Bypass relay fault</p> <ul style="list-style-type: none"> • Press the ESC key to restart the inverter. • Contact SolaX for help if it cannot return to normal.
IE 41	ArcFault	<p>Arc fault</p> <ul style="list-style-type: none"> • Check whether the cables between the PV modules and the inverter work normally. • Contact SolaX for help if it cannot return to normal.
IE 101	PowerTypeFault	<p>Power type fault</p> <ul style="list-style-type: none"> • Upgrade the software and press the ESC key to restart the inverter. • Contact SolaX for help if it cannot return to normal.
IE 102	Port OC Warning	<p>EPS (Off-grid) terminal overcurrent fault</p> <ul style="list-style-type: none"> • Check if the EPS (Off-grid) load exceeds the system requirements, and press the ESC key to restart the inverter. • Contact SolaX for help if it cannot return to normal.
IE 103	Mgr EEPROM Fault	<p>Manager EEPROM fault</p> <ul style="list-style-type: none"> • Shut down photovoltaic, battery and grid, and then reconnect. • Contact SolaX for help if it cannot return to normal.
IE 104	SmartCtrlComErr	<p>Datahub communication fault</p> <ul style="list-style-type: none"> • Check whether the communication cable between the inverter and the datahub is connected correctly. • Check whether the baud rate for datahub is set correctly. • Contact SolaX for help if it cannot return to normal.
IE 105	ArcSelfTestFault	Contact SolaX for help.
IE 106	ArcHWFault	Contact SolaX for help.
IE 107	Bat Temp High	<p>Battery temperature high</p> <ul style="list-style-type: none"> • Check the battery installation environment to ensure good heat dissipation. • Contact SolaX for help if it cannot return to normal.

Error Code	Fault	Diagnosis and Solutions
IE 109	Meter Fault	<p>Meter fault</p> <ul style="list-style-type: none"> • Check if the meter is normal and is compatible with the inverter. • Check if the communication cable is normal and properly connected. • Check if the communication settings such as protocol, address and baud rate of the meter are consistent with those of the inverter. • Contact SolaX for help if it cannot return to normal.
IE 110	BypassRelayFlt	<p>Bypass relay fault</p> <ul style="list-style-type: none"> • Press the ESC key to restart the inverter. • Contact SolaX for help if it cannot return to normal.
IE 111	ARMParaComFlt	<p>ARM parameter communication fault</p> <ul style="list-style-type: none"> • Check that the communication cables of inverters are well connected and the baud rate of COMM setting of inverters are the same. • Contact SolaX for help if it cannot return to normal.
IE 112	FAN1 Fault	<p>FAN1 fault</p> <ul style="list-style-type: none"> • Check if the foreign objects stuck in the fan. • Contact SolaX for help.
IE113	FAN2 Fault	<p>FAN2 fault</p> <ul style="list-style-type: none"> • Check if the foreign objects stuck in the fan. • Contact SolaX for help.
IE108	FAN3 Fault	<p>FAN3 fault</p> <ul style="list-style-type: none"> • Check if the foreign objects stuck in the fan. • Contact SolaX for help.
BE 01	BMS1_Exter_Err BMS2_Exter_Err	<p>Battery error - external communication fault</p> <ul style="list-style-type: none"> • Contact SolaX for help.
BE 02	BMS1_InterErr BMS2_InterErr	<p>Battery error - internal communication fault</p> <ul style="list-style-type: none"> • Contact SolaX for help.
BE 03	BMS1_OverVolt BMS2_OverVolt	<p>Over voltage in battery system</p> <ul style="list-style-type: none"> • Contact SolaX for help.
BE 04	BMS1_LowerVolt BMS2_LowerVolt	<p>Low voltage in battery system</p> <ul style="list-style-type: none"> • Contact SolaX for help.
BE 05	BMS1_ChargeOCP BMS2_ChargeOCP	<p>Battery fault - over charge fault</p> <ul style="list-style-type: none"> • Contact SolaX for help.

Error Code	Fault	Diagnosis and Solutions
BE 06	DischargeOCP1	Battery fault-discharge over current fault • Contact SolaX for help.
	DischargeOCP2	
BE 07	BMS1_TemHigh	Over temperature in battery system • Contact SolaX for help.
	BMS2_TemHigh	
BE 08	BMS1_TempLow	Battery temperature sensor malfunction • Contact SolaX for help.
	BMS2_TempLow	
BE 09	CellImblance1	Battery Unbalanced Fault • Contact SolaX for help.
	CellImblance2	
BE 10	BMS1_Hardware	Battery hardware protection fault • Contact SolaX for help.
	BMS2_Hardware	
BE 11	BMS1_Circuit	Battery circuit fault • Restart the battery. • Contact SolaX for help.
	BMS2_Circuit	
BE 12	BMS1_ISO_Fault	Battery insulation fault • Check that the battery is properly grounded and restart the battery. • Contact SolaX for help.
	BMS2_ISO_Fault	
BE 13	BMS1_VolSen	Battery voltage sensor fault • Contact SolaX for help.
	BMS2_VolSen	
BE 14	BMS1_TempSen	Temperature sensor fault • Restart the battery. • Contact SolaX for help.
	BMS2_TempSen	
BE 15	BMS1_CurSen	Battery current sensor fault • Contact SolaX for help.
	BMS2_CurSen	
BE 16	BMS1_Relay	Battery relay fault • Contact SolaX for help.
	BMS2_Relay	
BE 17	TypeUnmatch1	Battery type fault • Upgrade the battery BMS software. • Contact SolaX for help.
	TypeUnmatch2	
BE 18	Ver Unmatch1	Battery version mismatch fault • Upgrade the battery BMS software. • Contact SolaX for help.
	Ver Unmatch2	

Error Code	Fault	Diagnosis and Solutions
BE 19	MFR Unmatch1	Battery manufacturer mismatch fault <ul style="list-style-type: none"> • Upgrade the battery BMS software. • Contact SolaX for help.
	MFR Unmatch2	
BE 20	SW Unmatch1	Battery hardware and software mismatch fault <ul style="list-style-type: none"> • Upgrade the battery BMS software. • Contact SolaX for help.
	SW Unmatch2	
BE 21	M&S Unmatch1	Battery master slave control mismatch fault <ul style="list-style-type: none"> • Upgrade the battery BMS software. • Contact SolaX for help.
	M&S Unmatch2	
BE 22	CR NORespond1	Battery charging request no respond <ul style="list-style-type: none"> • Upgrade the battery BMS software. • Contact SolaX for help.
	CR NORespond2	
BE 23	BMS1 SW Protect	Battery slave software protection failure <ul style="list-style-type: none"> • Upgrade the battery BMS software. • Contact SolaX for help.
	BMS2 SW Protect	
BE 24	BMS1 536 Fault	Battery discharge over current fault <ul style="list-style-type: none"> • Contact SolaX for help.
	BMS2 536 Fault	
BE 25	BMS1 SelfCheck	Over temperature in battery system <ul style="list-style-type: none"> • Contact SolaX for help.
	BMS2 SelfCheck	
BE 26	BMS1 Tempdiff	Battery temperature sensor malfunction <ul style="list-style-type: none"> • Contact SolaX for help.
	BMS2 Tempdiff	
BE 27	BMS1_BreakFault	Battery unbalanced fault <ul style="list-style-type: none"> • Contact SolaX for help.
	BMS2_BreakFault	
BE 28	BMS1_FlashFault	Battery hardware protection failure <ul style="list-style-type: none"> • Contact SolaX for help.
	BMS2_FlashFault	
BE 29	BMS1_Precharge	Battery precharge fault <ul style="list-style-type: none"> • Contact SolaX for help.
	BMS2_Precharge	
BE 30	AirSwitchBreaker1	Battery air switch fault <ul style="list-style-type: none"> • Check if the battery breaker is off. • Contact SolaX for help.
	AirSwitchBreaker2	
BE 31	ClusterCntMIS1	Cluster communication loss <ul style="list-style-type: none"> • Check the communication cables for the master control and parallel connection box.
	ClusterCntMIS2	

Error Code	Fault	Diagnosis and Solutions
BE 32	ClusterComAddr1	Cluster address repeated
	ClusterComAddr2	<ul style="list-style-type: none"> • Wait for the system to restore automatically. If the system fails to restore, try to restart the battery.
/	Screen not on	<ul style="list-style-type: none"> • Check if the inverter correctly and normally connected to PV, battery or grid. • Contact SolaX for help if the inverter is connected correctly.
/	Abnormal sound on fan	<ul style="list-style-type: none"> • Check if there is foreign objects stuck in the fan. • Contact SolaX for help.
/	Screen on but no content display	<ul style="list-style-type: none"> • Contact SolaX for help.
/	LCD screen stuck in Wait state	<p>Check whether the input voltage of PV is greater than 140 V and the input voltage of battery is greater than 130 V.</p> <ul style="list-style-type: none"> • If it meets the requirement, contact SolaX for help. • If the input voltage of battery or PV is less than the specified value, check the corresponding connection.
/	No readings after CT connection	<ul style="list-style-type: none"> • Check if CT is correctly clipped on the L wire • Check if the arrow on the CT points at Grid. • Contact SolaX for help if it cannot return to normal.
/	No readings on Load (on App or Web)	<ul style="list-style-type: none"> • Check if the load is connected correctly. • Check if the power of load on the LCD screen displays normally. • Check if the monitoring module works normally. • Contact SolaX for help if it cannot return to normal.
/	No readings on Grid (on App or Web)	<ul style="list-style-type: none"> • Check if the grid connection is normal. • Check if the grid parameter on the LCD screen displays normally. • Check if the monitoring module works normally. • Contact SolaX for help if it cannot return to normal.
/	No readings on battery (on App or Web)	<ul style="list-style-type: none"> • Check if the battery is connected correctly. • Check if the battery parameter on the LCD screen displays normally. • Check if the monitoring module works normally. • Contact SolaX for help if it cannot return to normal.
/	No Feedin data (on App or Web)	<ul style="list-style-type: none"> • Check if the meter/CT is connected correctly. • Check if the meter/CT parameter on the LCD screen displays normally. • Check if the monitoring module works normally. • Contact SolaX for help if it cannot return to normal.

Error Code	Fault	Diagnosis and Solutions
/	No data on App or Web	<ul style="list-style-type: none">• Check if the monitoring module works normally.• Contact SolaX for help.
/	No display on meter after power on	<ul style="list-style-type: none">• If the meter connection is abnormal, reconnect them according to the wiring diagrams.• Wait for the grid voltage to restore.• Contact SolaX for help if it cannot return to normal.
/	Abnormal electrical data on meter	<ul style="list-style-type: none">• If the wiring is incorrect, reconnect them based on the wiring diagrams.• Set the voltage and current ratio according to the setting steps of meter user manual.• Contact SolaX for help if it cannot return to normal.

12.3 Maintenance

Regular maintenance is required for the inverter. Please check and maintain the following items based on the instructions below to ensure the optimal performance of the inverter. For inverters working in inferior conditions, more frequent maintenance is required. Please keep maintenance records.



- Only qualified person can perform the maintenance for the inverter.
- Only spare parts and accessories authorized by SolaX can be used for maintenance.

12.3.1 Maintenance Routines

Table 12-2 Proposal of Maintenance

Item	Check notes	Maintenance interval
Fans	<ul style="list-style-type: none"> • Check if the fan makes noise or is covered by dust. • Clean the fan with a soft and dry cloth or brush, or replace the fan if necessary. 	Every 12 months
Electrical connection	<ul style="list-style-type: none"> • Ensure that all cables are firmly connected. • Check the integrity of the cables, ensuring that there are no scratches on the parts touching the metallic surface. • Verify that the sealing caps on idle terminals are not falling off. 	Every 12 months
Grounding reliability	<ul style="list-style-type: none"> • Check if the grounding cables are firmly connected to the grounding terminals. Use a ground resistance tester to test the grounding resistance from the inverter enclosure to the PE bar in the power distribution box. 	Every 12 months
Heat sink	<ul style="list-style-type: none"> • Check if there are foreign objects in the heat sink. 	Every 12 months
General status of inverter	<ul style="list-style-type: none"> • Check if there is any damage on the inverter. • Check if there is any abnormal sound when the inverter is running. 	Every 6 months

If the fan is broken, replace it in the following way:

Step 1: Remove cables and connectors for the Grid&EPS terminal, MPPT terminal, BAT/V2X terminal and grounding point with the corresponding tools. Take down the anti-theft lock (if any).

NOTICE!

For details about disassembling the inverter, please refer to “13 Decommissioning”.

- Step 2:** Take the inverter down from the wall and slightly put it on a foam cushion with the back surface upward. Remove 4 fastening screws from the back of the device with a cross screwdriver and disconnect the cables from the fan.

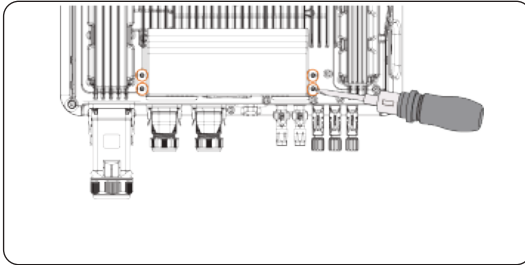

- Step 3:** Remove 4 screws on the fan cover with a cross screwdriver and take the fan cover down.

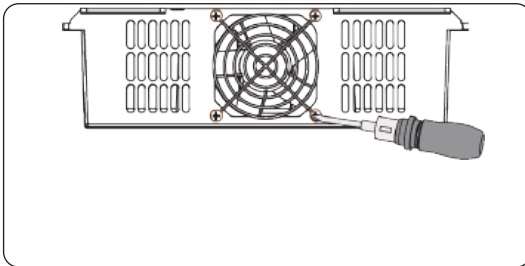

- Step 4:** Replace with a new fan (pay attention to the installation direction of the fan) and fasten the screws for the fan.
- Step 5:** Reconnect the cables to the fan and put the fan cover back.
- Step 6:** Hang the inverter onto the wall and connect the connectors and cables to the Grid&EPS terminal, MPPT terminal, BAT/V2X terminal and grounding point.

12.3.2 Upgrading Firmware

WARNING!

- Make sure that the type and format of the firmware file are correct. Do not modify the file name. Otherwise, the inverter may not work properly.
- Do not modify the folder name and file path where the firmware files are located. Otherwise, the upgrade will fail.

WARNING!

- Before upgrading, ensure that the PV input voltage is higher than 180 V (preferably on sunny day), the battery SOC is higher than 20%, or the battery input voltage is higher than 180 V. Failure to meet one of these conditions may result in upgrade process failure.

Upgrade preparation

- Prepare a USB drive (USB 2.0/3.0, ≤32 GB, FAT 16/32).
- Check for the current firmware version of the inverter.
- Contact our service support for the update firmware file, and save it to the USB drive.
 - » For ARM file: XXXXXXXXXXXX_HYB_3P_ARM_PRO_VXXX.XX_XXXX.bin
 - » For DSP file: XXXXXXXXXXXX_HYB_3P_DSP_PRO_VXXX.XX_XXXXXXXXX.bin
- Check the folder name and file path:

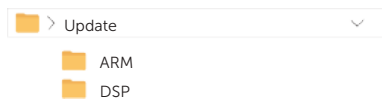
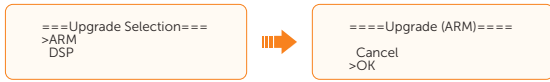

Figure 12-4 Folder name and path

Upgrade steps

- Press and hold the **Enter** key on the inverter LCD for 5 seconds to enter the **OFF** mode.
- Remove the dongle from the Dongle terminal of the inverter by hand, and then insert the USB drive. The inverter will automatically display the **Upgrade Selection** interface. (For the position of Dongle terminal, refer to [“8.1.1 Terminals and Parts of Inverter”](#).)
- On the **Upgrade Selection** interface, select **ARM** or **DSP** based on the file type, and then tap **OK**.



- d. Select and confirm the firmware version, and then press **Enter** key to start updating. ARM update takes about 20 seconds, and DSP update takes about 2 minutes.

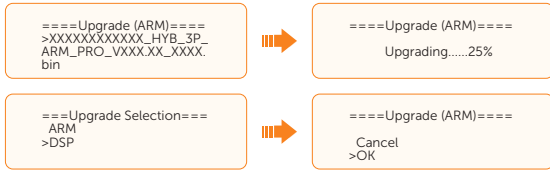

- e. If upgrade succeeds, the LCD screen will display **Upgrade Successful**. If upgrade fails, the LCD screen will display **Upgrade failed**.

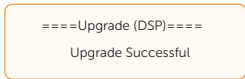

CAUTION!

- If the ARM firmware upgrade fails, do not unplug the USB drive. Restart the inverter and repeat the above operations.
- If the DSP firmware upgrade fails, check whether the DC switch is turned off.
 - » If it is off, turn it on.
 - » If it is on, check if the battery and PV parameters in **Menu>System Status** meet the upgrade requirements (the PV or battery input voltage should be larger than 180 V, or the battery SOC should be higher than 20%). If the battery SOC is lower than 20%, select **Menu>Mode Select>Manual>Forced Charge** to charge the battery.

NOTICE!

If the LCD screen lags or freezes after the upgrade, turn off the DC switch, and then restart the inverter. Check if the inverter returns to normal. If not, contact us.

Related Operation

Besides firmware upgrade, you can also import or export a configuration file by means of USB. After entering the **Upgrade Selection** interface according to the upgrade steps in **"12.3.2 Upgrading Firmware"**, follow the steps below to import or export a configuration

file:

Export file

- a. On the **Upgrade Selection** interface, select **Config File** and then tap **OK**.
- b. Enter the password. The initial password is "6868".

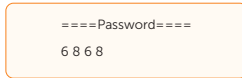

- c. Select **Export File** and then tap **OK**.



- d. Export a file successfully and press the **ESC** key to exit from the current interface.

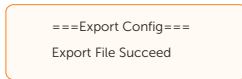

Import file

- a. On the **Upgrade Selection** interface, select **Config File** and then tap **OK**.
- b. Enter the password. The initial password is "6868".

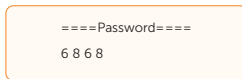

- c. Select **Import File**.

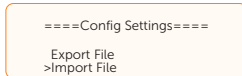

- d. Select the file to be imported and then tap **OK**.



- e. Import a file successfully.

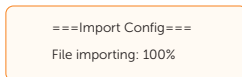

NOTICE!

If you failed in importing or exporting a file, press the **ESC** key to exit from the interface. Find out the root cause, solve the problem, and try again.

13 Decommissioning

13.1 Disassembling the Inverter



- Strictly follow the steps below to disassemble the inverter.
- Disassemble the PV connector, battery connector, AC connector, and communication connector with the dedicated PV removal tool and others separately.

Step 1: Turn off the system through the LCD.

Step 2: Disconnect the external AC breaker of the inverter.

Step 3: Rotate the DC switch to **OFF**.

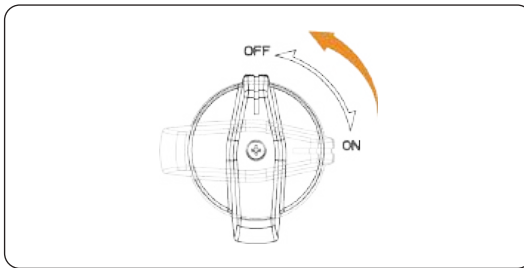

Figure 13-1 Switching off

Step 4: Turn off the battery switch / button / breaker (if any). (Refer to documents of battery)

Step 5: Disconnect the PV connectors: Insert the dedicated PV removal tool into the notch of PV connectors and slightly pull out the connectors.

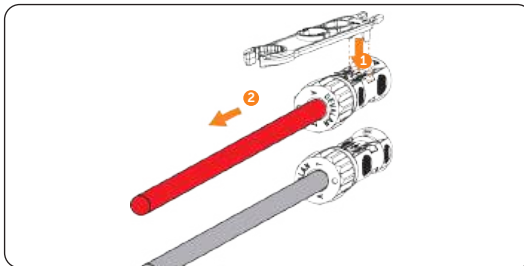

Figure 13-2 Disconnecting the PV connector

Step 6: Slightly pull out the dongle module.

- Step 7:** Disconnect the battery connectors: Insert a flat screwdriver into the notch of connectors and slightly pull out the connectors.

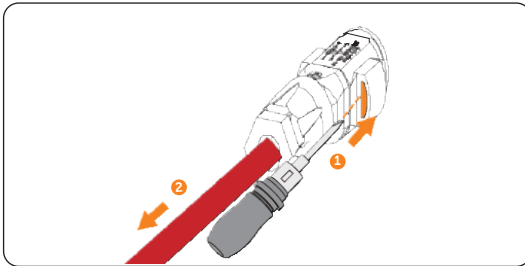

Figure 13-3 Disconnecting the battery connector

- Step 8:** Disconnect the AC connector: Loosen the screw on the latch with an Allen key, pull the latch up to 45°, and slightly pull the connector out.

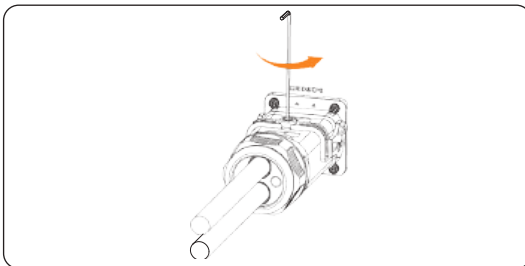

Figure 13-4 Loosening the screw

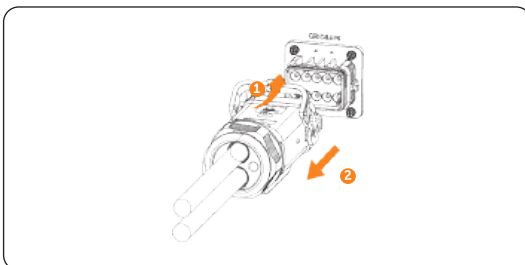

Figure 13-5 Pulling the latch up and pulling the connector out

- Step 9:** Disconnect the COM 1 connector and COM 2 connector: Loosen the screw of the COM connector and anti-clockwise loosen M3 screw of the communication connector by a cross screwdriver. Pinch latches on both sides of the connector enclosure with one hand and pull the connector with the other hand until communication cables inside it are exposed. Unplug the communication cables from the COM 1 or COM 2 terminal (with a flat screwdriver if needed). Remove all cables from the connector. Put the sealing plug and cable support sleeve to the

original positions, fasten the swivel nut, connect the connector to the device and tighten the screw on the connector.

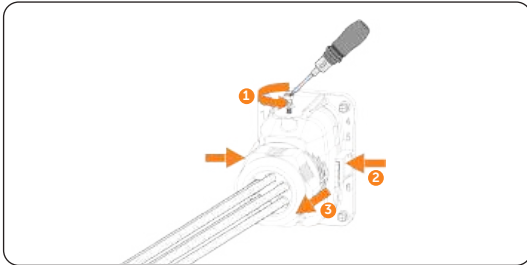

Figure 13-6 Disconnecting the communication connector

- Step 10:** Put the original terminals caps back to the terminals.
- Step 11:** Unscrew the grounding screw with an Allen key and remove the grounding cable.
- Step 12:** (Optional) Unlock the anti-theft lock if you installed it.
- Step 13:** Unscrew the M5 screw on the left side of the inverter and vertically lift up the inverter to dismantle the inverter.

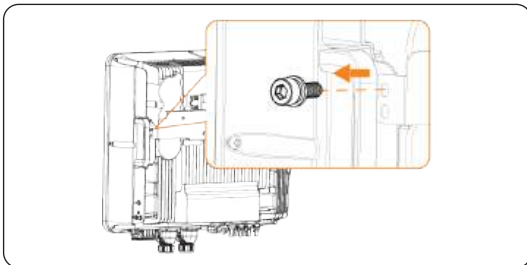

Figure 13-7 Removing the M5 screw

- Step 14:** Unscrew the screw for fastening the wall mounting bracket and remove the wall mounting bracket if needed.

13.2 Packing the Inverter

- Use the original packaging materials if available.

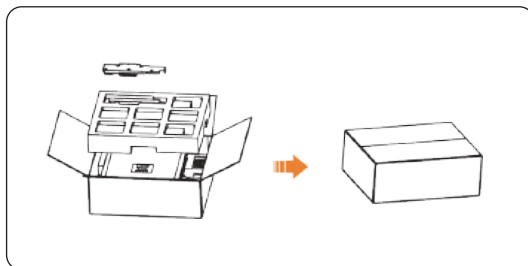

Figure 13-8 Packing the inverter

- If the original packing material is not available, use the packing material which meets the following requirements:
 - » Suitable for the weight and dimension of product
 - » Convenient for transportation
 - » Can be sealed with adhesive tape

13.3 Disposing of the Inverter

Properly dispose of the inverter and accessories in accordance with local regulations on the disposal of electronic waste.

14 Technical Data

- DC Input

Model	X3-HYB-4.0-P	X3-HYB-5.0-P	X3-HYB-6.0-P	X3-HYB-8.0-P	X3-HYB-10.0-P	X3-HYB-10.0K-P	X3-HYB-12.0-P	X3-HYB-15.0-P
Max. recommended DC power[W]	8000	10000	12000	16000	20000	20000	24000	30000
Maximum power of each MPPT	The power of each MPPT \leq rated power of the whole machine							
Max. DC voltage [V]	1000							
Nominal DC operating voltage [V]	650							
Max. input current (input A/input B/input C/input D) [A]	PV1: 20/PV2: 20			PV1: 20/PV2: 20/PV3: 20				
TA=45 C	PV1: 16/PV2: 16			PV1: 16/PV2: 16/PV3: 16				
Max. short circuit current (input A/input B) [A]	PV1: 25/PV2: 25			PV1: 25/PV2: 25/PV3: 25				
Max. inverter backfeed current to the array	0 d. c. A							
MPPT voltage range [V]	110-950							
MPPT voltage range [V] (full load)	330-800							
Halt	330V 16A*3							
Start input voltage [V] light screen	120							
Start output voltage [V] on-grid	140							
No. of MPP trackers	2			3				
Strings per MPP tracker	PV1: 1/PV2: 1			PV1: 1/PV2: 1/PV3: 1				
DC disconnection switch	Yes							

- AC Output (On-grid)

Model	X3-HYB-4.0-P	X3-HYB-5.0-P	X3-HYB-6.0-P	X3-HYB-8.0-P	X3-HYB-10.0-P	X3-HYB-10.0K-P	X3-HYB-12.0-P	X3-HYB-15.0-P
Nominal AC power [VA]	4000	5000 (4999 for AS 4777)	6000	8000	10000 (9999 for AS 4777)	10000	12000	15000 (14999 for AS 4777)
Max. apparent AC power [VA]	4400	5500 (4999 for AS 4777)	6600	8800	11000 (9999 for AS 4777)	10000	13200	16500 (14999 for AS 4777)
Rated grid voltage (AC voltage range) [V]	400/380							
Rated grid Frequency [Hz]	50/60							
Nominal AC current [A]@230V	5.8	7.2	8.7	11.6	14.5	14.5	17.5	21.8
Max. AC current [A]@220V	6.7	8.4	10.0	13.4	16.7	14.5	20.0	25.0
Current (inrush)	115 a.c.A (rms)							
Max. output fault current	85 a.c.A (peak)							
Max. output overcurrent protection	88 a.c.A (peak)							
Displacement power factor	~1 (Adjustable from 0.8 leading to 0.8 lagging)							
Total harmonic distortion (THD _i , rated power)	<3%							
Parallel operation	Yes							
Load control	Yes							

Technical Data

- AC Input

Model	X3-HYB-4.0-P	X3-HYB-5.0-P	X3-HYB-6.0-P	X3-HYB-8.0-P	X3-HYB-10.0-P	X3-HYB-10.0K-P	X3-HYB-12.0-P	X3-HYB-15.0-P
Nominal AC power[VA]	8000	10000	12000	16000	20000	20000	20000	20000
Nominal AC current [A]	11.6	14.5	17.4	23.2	29.0	29.0	29.0	29.0
Max. AC current [A]	12.2	15.2	18.2	24.3	30.4	30.4	30.4	30.4
Rated grid voltage (AC voltage range) [V]	400/380							
Rated grid Frequency[Hz]	50/60							
Power factor	~1 (Adjustable from 0.8 leading to 0.8 lagging)							

- Battery

Model	X3-HYB-4.0-P	X3-HYB-5.0-P	X3-HYB-6.0-P	X3-HYB-8.0-P	X3-HYB-10.0-P	X3-HYB-10.0K-P	X3-HYB-12.0-P	X3-HYB-15.0-P
Battery voltage range [V]	130-800							
Recommended battery voltage [V]	400 d. c. V							
Max.charge/ discharge power [W]	1.1 Pn/2 Pn							
Bat 1 Max.charge/ discharge current [A] Bat 2 Max.charge/ discharge current [A]	30 (25*) d. c. A /30 (25*) d. c. A ** indicates the current when Bat 1 and Bat 2 both work.							
Bat 1 Peak charge/ discharge current [A] Bat 2 Peak charge/ discharge current [A]	30 (25*) d. c. A /30 (25*) d. c. A ** indicates the current when Bat 1 and Bat 2 both work.							
Communication interfaces	CAN/RS485							
Reverse connection protection	Yes							

- EPS Output

Model	X3-HYB-4.0-P	X3-HYB-5.0-P	X3-HYB-6.0-P	X3-HYB-8.0-P	X3-HYB-10.0-P	X3-HYB-10.0K-P	X3-HYB-12.0-P	X3-HYB-15.0-P
EPS continual apparent power [VA]	4000	5000	6000	8000	10000	10000	12000	15000
EPS rated voltage[V], Frequency [Hz]	400V/230VAC, 50/60							
EPS rated current [A]	5.8	7.2	8.7	11.6	14.5	14.5	17.5	21.8
EPS single-phase overload	Below 10k: 2Pn/3@10s, 50%Pn@ keep on; 12/15k, 5.5 kw@ keep on							
EPS peak power [W]	≤1.1Pn always running; 1.1Pn-2Pn 10s; > 2Pn report errors immediately							
Switch time [ms]	<10 ms							
Total harmonic distortion (THDv, linear Load)	<3%							
Parallel operation	Yes, 10							

- Efficiency, Safety and Protection

Model	X3-HYB-4.0-P	X3-HYB-5.0-P	X3-HYB-6.0-P	X3-HYB-8.0-P	X3-HYB-10.0-P	X3-HYB-10.0K-P	X3-HYB-12.0-P	X3-HYB-15.0-P
MPPT efficiency	99.90%							
Euro-efficiency	97.70%							
Max. efficiency	98.00%							
Rated battery charge/discharge efficiency	98.5%/97.00%							
Safety	IEC62109-1/IEC62109-2							
Protection class	IP66							
Protective class	I							

Technical Data

- Power consumption

Model	X3-HYB-4.0-P	X3-HYB-5.0-P	X3-HYB-6.0-P	X3-HYB-8.0-P	X3-HYB-10.0-P	X3-HYB-10.0K-P	X3-HYB-12.0-P	X3-HYB-15.0-P
Internal consumption (night) [W]	<40W for hot standby, <5W for cold standby							
Idle mode	Yes							

- Standard

Model	X3-HYB-4.0-P	X3-HYB-5.0-P	X3-HYB-6.0-P	X3-HYB-8.0-P	X3-HYB-10.0-P	X3-HYB-10.0K-P	X3-HYB-12.0-P	X3-HYB-15.0-P
EMC	EN 61000-6-1 / EN 61000-6-2 / EN 61000-6-3							
Certification	VDE 0126-1-1 A1:2012 / VDE-AR-N 4105 / G98/G99/ AS4777 / EN50549/ CEI 0-21							

- Environment limit

Model	X3-HYB-4.0-P	X3-HYB-5.0-P	X3-HYB-6.0-P	X3-HYB-8.0-P	X3-HYB-10.0-P	X3-HYB-10.0K-P	X3-HYB-12.0-P	X3-HYB-15.0-P
Operating temperature range [°C]	-35°C~60°C (derating at +45°C)							
Humidity [%]	0~100 (condensing)							
Altitude [m]	≤3000							
Storage temperature [°C]	-40°C~65°C							
Pollution degree	Outdoor Min. PD3							
Noise emission (typical) [dB]	<35						<45	
Over voltage category	III (Electric supply side), II (PV side and battery side)							

- General paramters

Model	X3-HYB-4.0-P	X3-HYB-5.0-P	X3-HYB-6.0-P	X3-HYB-8.0-P	X3-HYB-10.0-P	X3-HYB-10.0K-P	X3-HYB-12.0-P	X3-HYB-15.0-P
Cooling concept	/						Nature Convection, FAN	
Topology	Non-isolated							
Active anti-islanding method	SMS							
AFCI	Standard for Brazil; Optional for other countries or regions							
Communication	COM 1 (including terminals Meter/CT, RS485, BMS 1, BMS 2, PARA 1, and PARA 2) and COM 2 (including terminals SMART CTRL/DATAHUB, HEATPUMP, EVC, V2X, DI/DO, and DRM)							
LCD display	LCD							
Dimensions [mm] outer frame	560*503*210							
Net weight [kg]	38							

* The specific gross weight is subject to the actual situation of the whole machine.

15 Appendix

15.1 Application of Generator

15.1.1 Introduction of Generator Application

When the utility power supply is unavailable, the system can seamlessly switch to a generator, to form a new energy supply system, thereby ensuring uninterrupted operation of loads.

In this case, the generator functions as the utility grid to supply power to the loads, and the hybrid inverter converts the solar energy to electricity.

15.1.2 Notice for Generator Application

- Note 1: The generator should be equipped with an ATSE, enabling it to start automatically in the event of a power outage.
- Note 2: The rated output power of the generator should be greater than the sum of the load power and the battery charging power. If there are multiple inverters connected in parallel, the rated output power of the generator should be greater than the sum of the load power and the battery charging power of all the inverters.
- Note 3: If the rated output power of the generator is small and cannot meet the requirements of Note 2, the setting value of **MaxChargePower** can be changed by selecting **Menu>Settings>Advanced Settings>Peripheral Settings>ExternalGen**, to ensure that the generator power can meet the total needs of loads and battery charging.
- Note 4: The EPS load power cannot be greater than the battery discharge power to prevent that the battery power cannot meet the requirements of EPS loads after the generator shuts down. Or the inverter will report an **Overload fault** alarm. If two inverters are connected in parallel, the EPS load power shall be doubled.

15.1.3 ATS Control Mode

In this mode, the generator functions as a substitute for the grid. There is no communication between the generator and the inverter, which means no wiring modifications are required (but the inverter cannot control the generator either). The ATS working for the generator determines whether to turn on the generator based on the status of the grid.

Wiring connection diagram

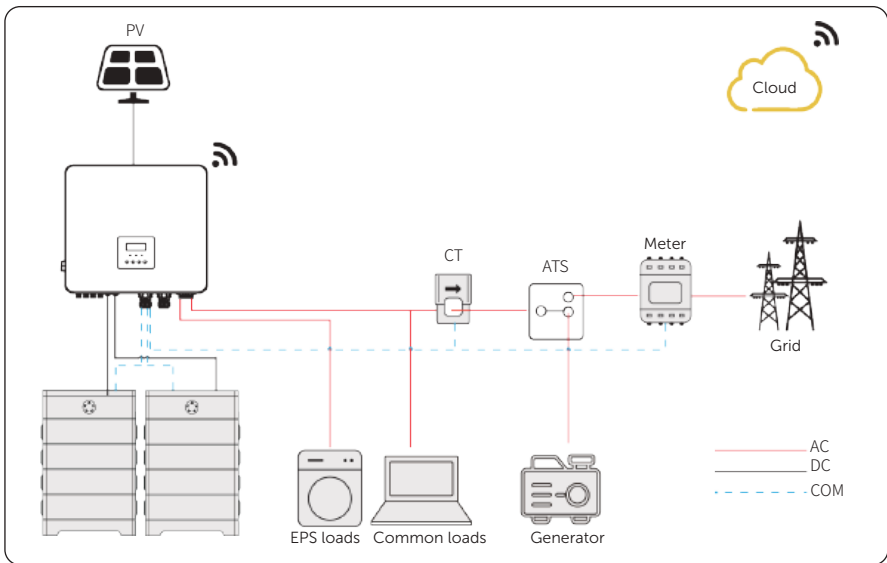

Figure 15-1 ATS control wiring diagram

Inverter settings for ATS control mode

- a. Select **Menu>Settings>Advanced Settings>ExternalGen>ATS Control**.

```
====ExternalGen====
>Function Control
  ATS Control
```

- b. Set the relative parameters as below in accordance with actual needs.

- » **MaxChargePower**: The maximum power of generator charging battery. (0-300000 W, 5000 W by default)

```
====ExternalGen====
>MaxChargePower
  XXXXW
```

- » **Char&Disc Period**: Including **Forced Charge Period** and **Allowed Disc Period**. Two periods can be set at most.

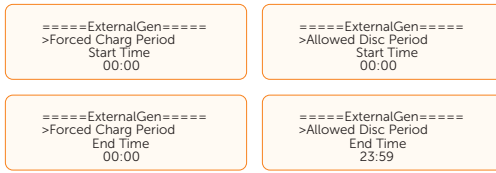

- » **Charge from Gen and Charge battery to:** It allows the battery to take power from the generator. You can set the battery target SOC (10-100%, 10% by default).



15.1.4 Dry Contact Mode

In this operating mode, users can intelligently control the system by establishing a dry contact connection between the inverter and the generator. It allows for adjustments to multiple settings so that the system can meet the requirements of different scenarios.

Wiring connection diagram

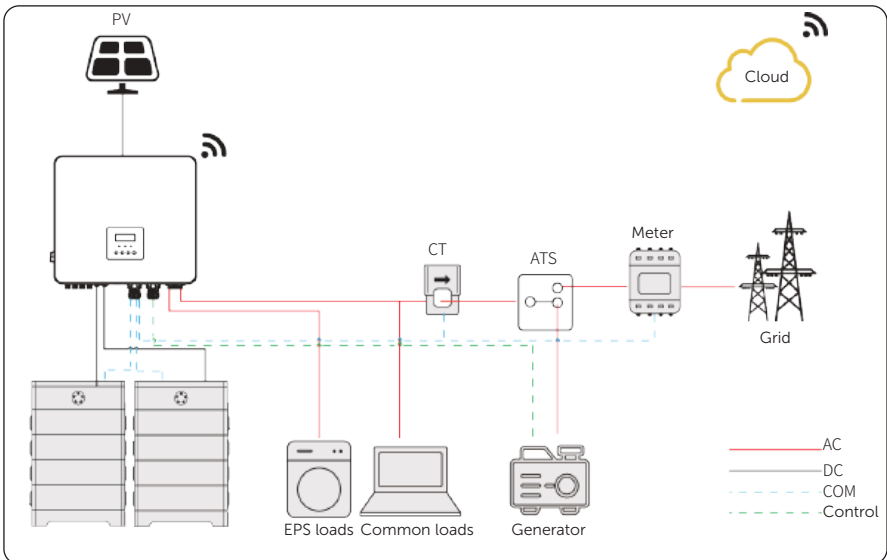

Figure 15-2 Dry contact wiring diagram

Inverter connection for dry contact mode

- Connection terminal: Sub-terminal DI/DO in terminal COM 2

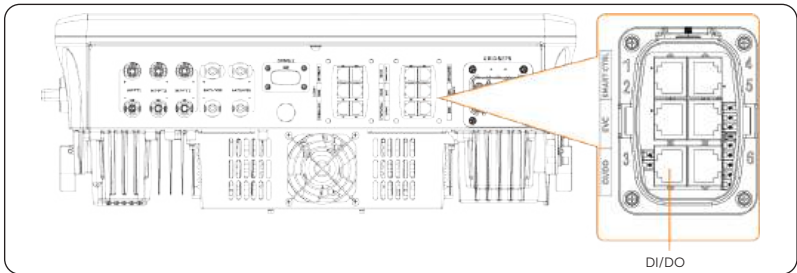

Figure 15-3 Connection terminal for generator

- Connection pins: Pin 7 and Pin 8 of terminal DI/DO

Table 15-1 Definition of pins of sub-terminal DI/DO

Pin	Definition	Description
1	DI1_A	Dry contact for input
2	DI1_B	
3	12V_COM_EXT	/
4	3.3V_COM	System off signal
5	INVERTER_OFF	
6	GND	Connected to the ground
7	DO2_A	Dry contact for output
8	DO2_B	

- Connection steps: Please refer to ["8.7.2 DI/DO Communication Connection"](#) for specific wire making and connection.
- Inverter settings for dry contact mode
 - a. Select **Menu>Settings>Advanced Settings>ExternalGen>Dry Contact**.

```
====ExternalGen====
>Function Control
  Dry Contact
```

- b. Set the relative parameters in accordance with actual needs.
 - » **MaxChargePower**: The maximum power of generator charging battery. (0-300000 W, 5000 W by default).

```
====ExternalGen====
>MaxChargePower
5000W
```

- » **Start Gen Method:** Two methods for you to select: **Reference SOC** and **Immediately**. **Reference SOC:** Turn on/off the generator according to the set battery SOC. **Immediately:** Turn on /off the generator immediately when the inverter disconnects from the grid.

```
====ExternalGen====
>Start Gen Method
Reference soc
```

```
====ExternalGen====
>Start Gen Method
Immediately
```

- » **Switch on/off SOC:** the option is activated when you select **Reference SOC** for **Start Gen Method**. The inverter will turn on the generator when the battery reaches the set **Switch on SOC** and turn it off when the battery reaches the set **Switch off SOC**.

```
====ExternalGen====
>Switch on SoC
0%
```

```
====ExternalGen====
>Switch off SoC
0%
```

- » **MaxRunTime:** Maximum operating time of generator. (1000 mins by default)

```
====ExternalGen====
>MaxRunTime
1000 Min
```

- » **MinRestTime:** Minimum time interval for two consecutive starts to avoid switching on and off frequently. (60 mins by default)

```
====ExternalGen====
>MaxRestTime
60Min
```

- » **Char&Disc Period:** Including **Forced Chrg Period** and **Allowed Disc Period**. Two periods can be set at most.

```
====ExternalGen====
>Forced Chrg Period
Start Time
00:00
```

```
====ExternalGen====
>Allowed Disc Period
Start Time
00:00
```

```
====ExternalGen====
>Forced Chrg Period
End Time
00:00
```

```
====ExternalGen====
>Allowed Disc Period
End Time
23:59
```

- » **Allow Work:** Allowed time period for generator operating. You can set the start time and end time.

```
====ExternalGen====
>Allow Work
Start Time
00:00
```

```
====ExternalGen====
>Allow Work
End Time
23:59
```

- » **Charge from Gen and Charge battery to:** It allows the battery to take power from the generator. You can set the battery target SOC (10-100%, 10% by

default).

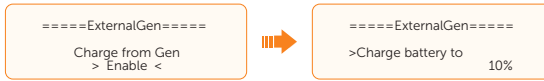

15.2 Application of Adapter Box

15.2.1 Introduction of Adapter Box Application

In real life, a heat pump be connected to a PV energy storage system via adapter box as controllable load. Through the adapter box, the surplus PV energy can be converted into the thermal energy for daily use. This intelligent integration not only optimizes solar energy consumption, but reduces electricity bills.

15.2.2 Wiring Connection Diagram

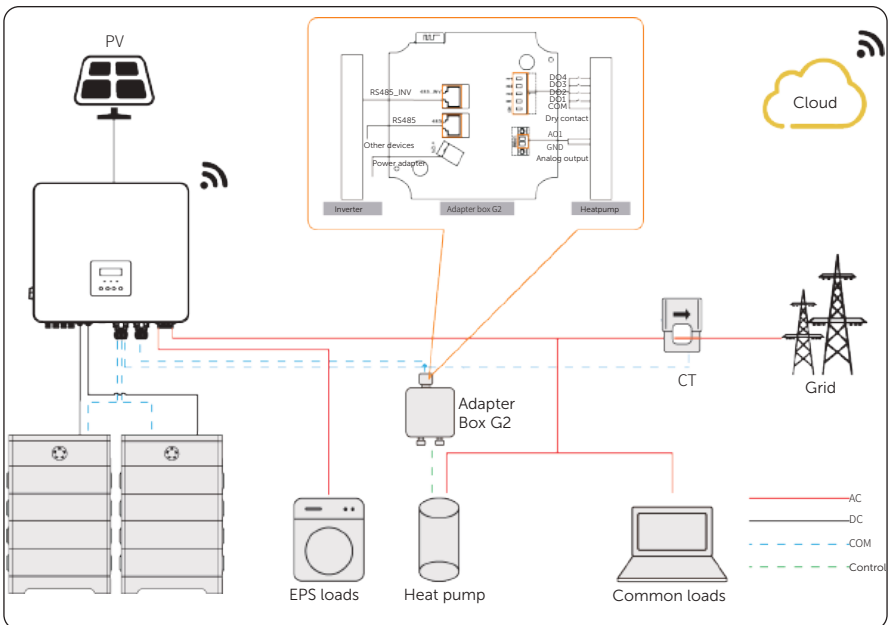

Figure 15-4 Adapter box G2 wiring diagram

Adapter box G2, with 4 dry contact and 1 analogue signal channels, can control heat pumps that support three types of signals: SG Ready, dry contact and analogue signal. By setting related parameters on the SolaXCloud App, you can control the pumps intelligently.

Adapter box G1 supports dry contact control signals only. By setting related parameters on the inverter LCD, you can control energy output of the inverter by threshold, battery SOC, duration, and schedule. It should be noted that, before setting, you need to turn the 3-way DIP switch to **OFF** (shown in the following figure), to make the device in factory settings.

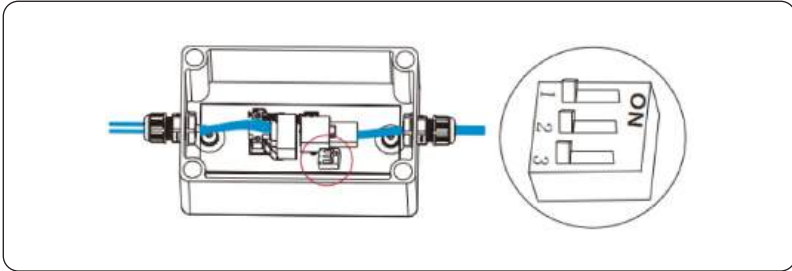

Figure 15-5 DIP switch in **OFF** position

15.2.3 Communication Connection with Inverter

- Connection terminal for adapter box: Sub-terminal HEATPUMP in terminal COM 2

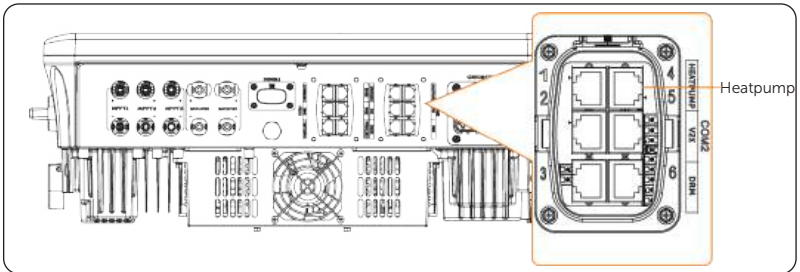

Figure 15-6 Connection terminal for adapter box

- Connection pins

Table 15-2 Pin-to-pin connection for inverter and adapter box G1

Sub-terminal HEATPUMP of inverter		Adapter box G1	
Pin	Definition	Pin	Definition
3	+12V_COM_EXT	3	+13V
6	GND	6	GND
7	DO1_A	7	Drycontact_A(out)
8	DO1_B	8	Drycontact_B(out)

Table 15-3 Pin-to-pin connection for inverter and adapter box G2

Sub-terminal HEATPUMP of inverter		Terminal RS485_INV of adapter box G2	
Pin	Definition	Pin	Definition
3	+12V_COM_EXT	3*	+12V
6	GND	6*	GND
4	HEATPUMP_485A_CON	4	RS485-A
5	HEATPUMP_485B_CON	5	RS485-B

* Besides this inverter, a power adapter can also supply power to adapter box G2, so pins 3 and 6 are selectively connected. Please choose a proper way as needed.

- Connection steps: Please refer to “8.7.1 Datahub, Heatpump, and EVC Communication Connection” for specific wire making and connection.

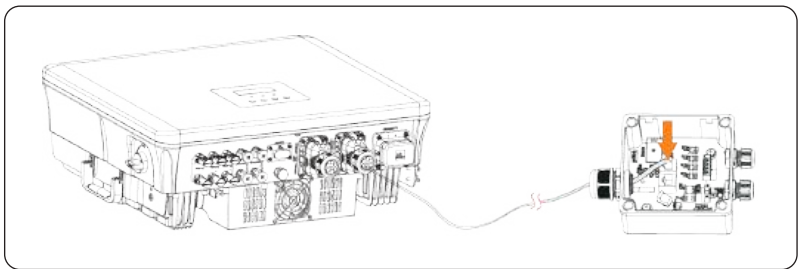

Figure 15-7 Connecting to adapter box G2

NOTICE!

The communication cable between the adapter box and the inverter cannot exceed 100 m.

15.2.4 Settings for Adapter box G2

- Select **Menu>Settings>Advanced Settings>Peripheral Settings>Internal485**.
- Select **HP(ADbox) Ctrl**. Set the baud rate and communication address for the device. The baud rate is 9600 by default.

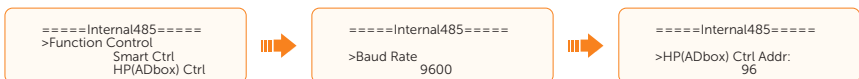

NOTICE!

When two devices are connected to the inverter simultaneously, their baud rates and address must be the same.

- c. Check the connection status of the device.

```
====Internal485====  
>HP(ADbox) Ctrl RTU  
Connected
```

NOTICE!

- For specific settings for adapter box G1, please refer to “Load Management”.
- For details about adapter box G1 and adapter box G2, refer to *Adapter Box G1 Installation Manual* and *Adapter Box G2 User Manual* respectively.

15.3 Application of EV-Charger

15.3.1 Introduction of EV-Charger Application

The EV-Charger is intended for charging electric vehicles. It should be installed in a fixed location and connected to the AC supply. The EV-Charger can communicate with other devices or systems (inverter, meter, CT, third-party charger management platform, etc.) to realize intelligent control of charging process.

15.3.2 Wiring Connection Diagram

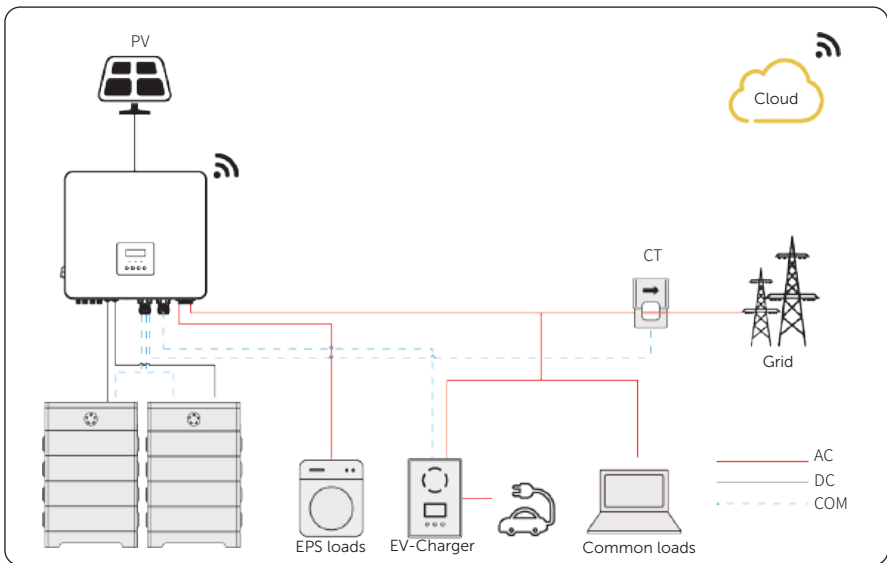

Figure 15-8 EV-Charger wiring diagram

15.3.3 Charging Modes

- Green mode: In Green mode, the EV-Charger will maximize the use of surplus power generated from the inverter. According to the minimum start-up charging power, the charging current can be divided into two levels: 3 A and 6 A. The default level is 3 A. If at any time, the available surplus power falls below the minimum start-up charging power, the EV-Charger will stop charging.
- Eco mode: In Eco mode, the charging power is continuously adjusted according to changes in generation or power consumption elsewhere in the house, thereby minimizing the use of the grid power. In this mode, users can set charging current at five different levels, i.e. 6 A, 10 A, 16 A, 20 A and 25 A (Only 6 A & 10 A for 11 kW models). If at any time, the available surplus power falls below the minimum start-

up charging power, such as 4.2 kW for three-phase, the shortfall will be drawn from the grid.

- Fast mode (Default mode): In Fast mode, the EV-Charger will charge the EV at the fastest rate regardless of whether the power generated by PV is sufficient and import grid electricity if the power generated by PV is insufficient.

15.3.4 Communication Connection with Inverter

- Connection terminal: Sub-terminal EVC in terminal COM 2

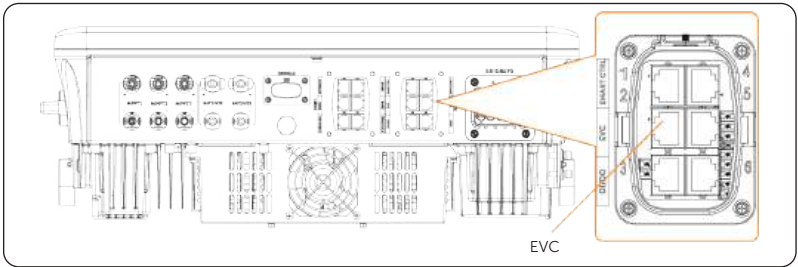

Figure 15-9 Connection terminal for EV-Charger

- Connection pins

Table 15-4 Pin-to-pin connection for inverter and EV-Charger

Sub-terminal EVC of inverter		Terminal COM of EV-Charger	
Pin	Definition	Pin	Definition
4	EVC_485A_CON	4	A1
5	EVC_485B_CON	5	B1

- Connection steps: Please refer to ["8.7.1 Datahub, Heatpump, and EVC Communication Connection"](#) for specific wire making and connection.

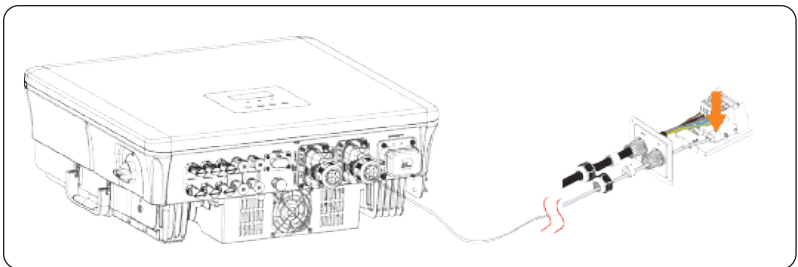

Figure 15-10 Connecting to EV-Charger

NOTICE!

The communication cable between EV-Charger and inverter cannot exceed 100 m.

15.3.5 Settings for EV-Charger

- Select **Menu>Settings>Advanced Settings>Peripheral Setstings>Internal485**.
- Select **EVCharger** and set the **Baud Rate** and corresponding address. The default **Baud Rate** is 9600.

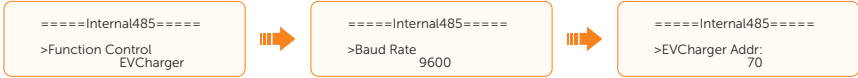

NOTICE!

When two devices need to be connected at the same time, the baud rate and address of the two devices shall be set to the same.

- Check the connection status.

```
====Internal485====
>EV Charger COM STAT
  Connected
```

- (Optional) You can enable **Battery Charge EVC** to allow the battery to discharge energy to the EV-Charger through setting path: **Menu>Settings>Advanced Settings>Battery Settings>Battery Charge EVC**.

```
===Battery Charge EVC===
>Function Control
  Enable
```

NOTICE!

For specific wiring and setting procedures of EV-Charger, refer to *X1/X3-EVC Series User Manual*.

15.4 Application of Datahub

15.4.1 Introduction of Datahub Application

A datahub can be connected to inverters through subterminal **SMART CTRL** (or **DATAHUB**) in terminal COM 2 to control the output power of the entire power station according to on-site requirements. Besides, it can work with SolaXCloud to monitor all inverters, allowing for real-time data display and device management. In the entire system, a maximum of ten X3-HYB G4 PRO series inverters can be connected to a datahub.

15.4.2 Wiring Connection Diagram

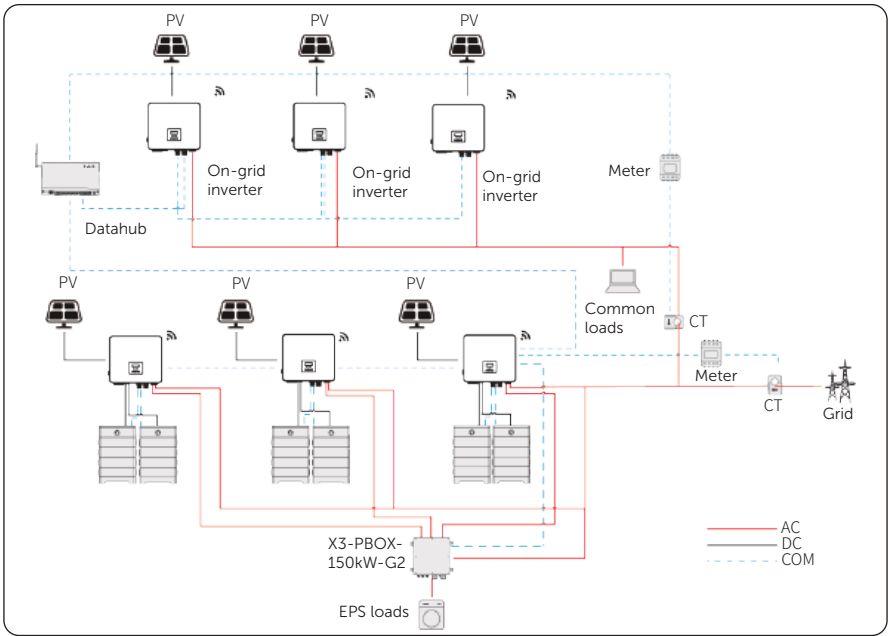

Figure 15-12 Databus wiring diagram

15.4.3 Communication Connection with Inverter

- Connection terminal: Sub-terminal **SMART CTRL** (or **DATAHUB**) in terminal COM 2

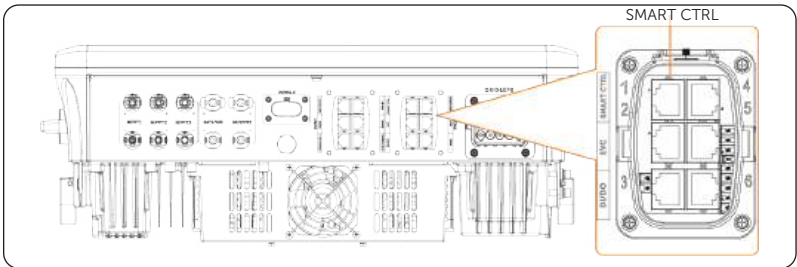

Figure 15-13 Connection terminal for databus

- Connection pins

Table 15-5 Pin-to-pin connection for inverter and datahub

Sub-terminal SMART CTRL (or DATAHUB) of inverter		Terminal RS485-1 of datahub	
Pin	Definition	Pin	Definition
4	DATAHUB_485A_CON	/	A+
5	DATAHUB_485B_CON	/	B-

- Connection steps: Please refer to “8.7.1 Datahub, Heatpump, and EVC Communication Connection” for wire making and connecting.

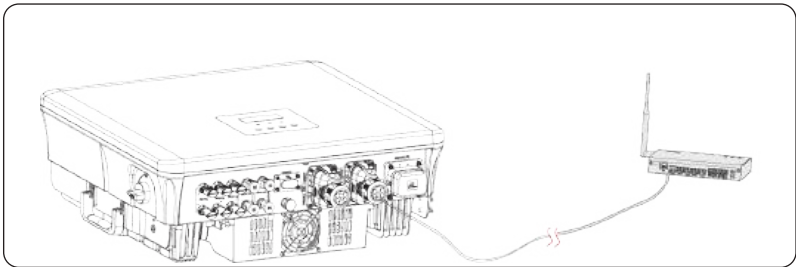

Figure 15-14 Connecting to datahub

NOTICE!

The communication cable between datahub and inverter cannot exceed 100 m.

15.4.4 Settings for Datahub

- Select **Menu>Settings>Advanced Settings>Peripheral Settings>Internal485**.
- Select **Smart Ctrl** and set the baud rate and corresponding address. The default baud rate is 9600.

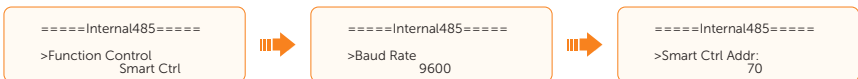

NOTICE!

- The baud rate, communication protocol and verification method of the inverters connected to the same terminal RS485 of a datahub must be consistent, and the communication addresses of the inverters must be consecutive.
- For specific wiring and setting procedures of datahub, refer to *Datahub 1000 User Manual*.

15.5 Application of Micro-grid

15.5.1 Introduction of Micro-grid Application

Due to the islanding effect, an on-grid inverter cannot work during off-grid. This characteristic makes user losing the on-grid inverter PV energy when off-grid. Micro-grid is the function that making hybrid inverter simulate the grid to active on-grid inverter during off-grid by connecting the on-grid inverter to hybrid inverter's EPS terminal.

15.5.2 Wiring Connection Diagram

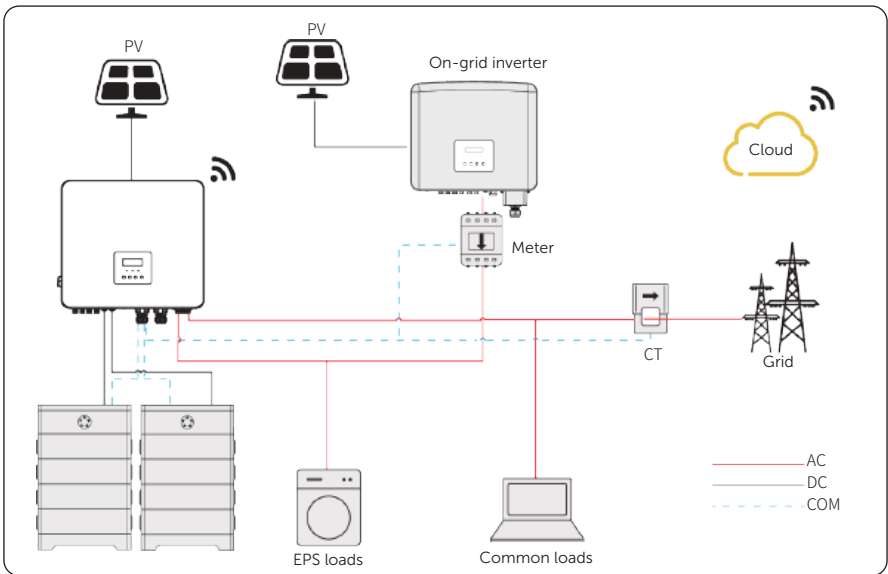

Figure 15-15 Micro-grid wiring connection

15.5.3 Working Modes

Grid on

- When PV is sufficient, the hybrid and on-grid inverters power the common and EPS loads together. When there is surplus energy on the on-grid inverter, it will also charge the battery.
- When PV is insufficient, the hybrid inverter, on-grid inverter and grid power the loads together.

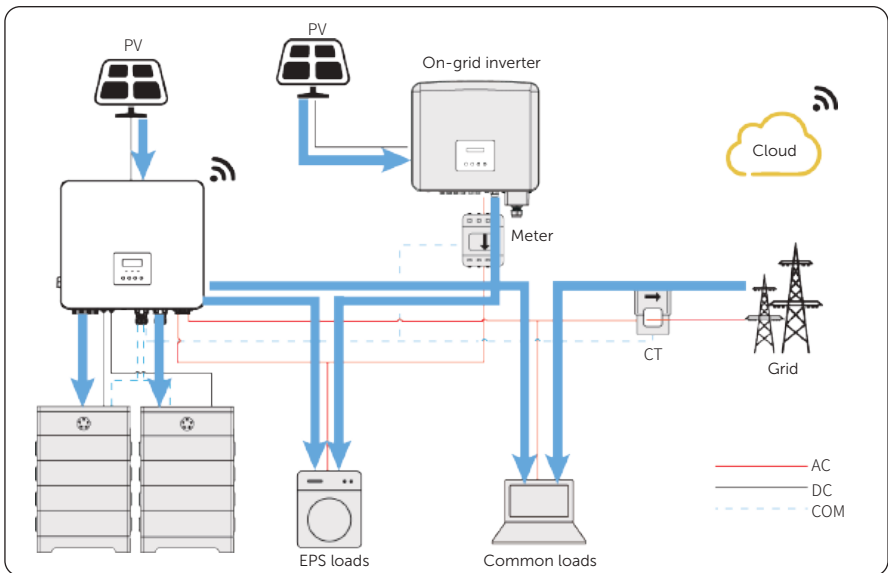

Figure 15-16 Power flowing when grid on and PV sufficient

Grid off

In this case, the hybrid inverter will simulate the grid so as to make the on-grid inverter work. Hybrid and on-grid inverter will power the EPS loads together. If there is surplus energy, it will charge the battery.

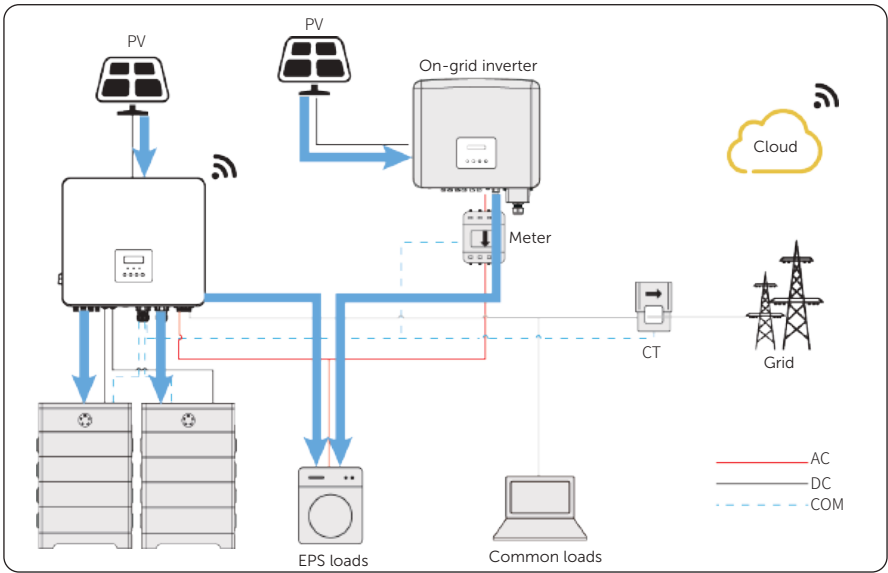

Figure 15-17 Power flowing when grid off

NOTICE!

In EPS mode, due to limited battery charging power, the hybrid inverter will increase the EPS output frequency to restrict and shut down the on-grid inverter, ensuring the stable operation of the entire system. In this period, the on-grid inverter may report a **Grid frequency Fault**, which is a normal phenomenon.

Notice for micro-grid application

- Any brand of on-grid inverter that supports "frequency adaptation"
- On-grid inverter output power \leq Max hybrid inverter EPS output power
- On-grid inverter output power \leq Max battery charging power

NOTICE!

Since X3-HYB G4 PRO series inverter is unable to control the output power of on-grid inverter in grid connection mode, the series inverter cannot achieve zero export when "loads power + battery charging power < on-grid inverter output power".

15.5.4 Cable Connection (Hybrid inverter)

Please refer to "8.3 AC Connection" for Grid and EPS connection of this inverter.

15.5.5 Cable Connection (On-grid inverter)

Please connect the AC cable of an on-grid inverter to the EPS terminal of X3-HYB G4 PRO series inverter. Please refer to the user manual of specific on-grid inverter.

15.5.6 Cable Connection (Meter)

To detect and monitor the power data generated from the on-grid inverter, install a meter on the on-grid inverter side. Otherwise, the relevant power data of on-grid inverter cannot be monitored.

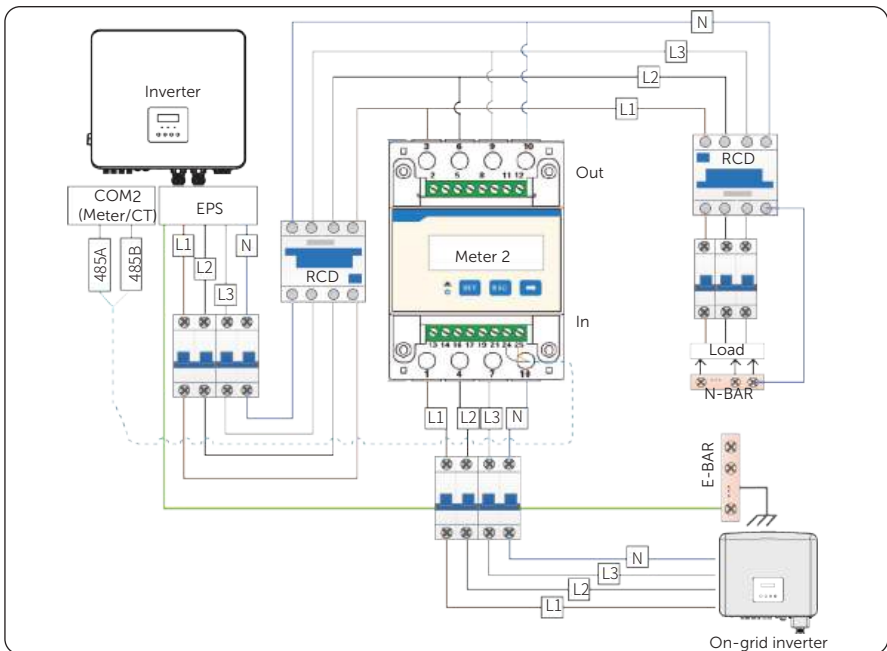
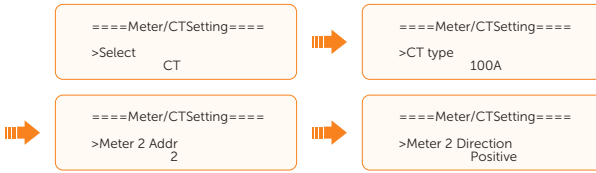

Figure 15-18 Connection diagram of Meter on EPS terminal

- For meter/CT connection steps, refer to [“8.6.1 Meter/CT Connection”](#) and meter/CT user manual.
- Settings on the LCD:
 - a. Select **Menu>Settings>Advanced Settings>Meter/CT Settings**.
 - b. Set parameters for meter or CT:
 - » Situation 1: CT is used for monitor the hybrid inverter, and Meter 2 is used to monitor the EPS terminal. Select **CT** and set the type of CT according to the actual situations. Set the address and direction of Meter 2. After all done, you can check the connection status of meter and CT at Meter/CT Check.



- » Situation 2: Meter 1 is used for monitor the hybrid inverter, and Meter 2 is used to monitor the EPS terminal. Select **Meter** and set the address and direction of Meter 1. For settings about Meter 2, refer to Situation 1. After all are done, you can check the connection status of meters through **Meter/CT Check**.



- c. If meter/CT connection succeeds, check the feed-in power of Meter 1 in the path of **Menu>System Status>Meter/CT** and check the output power (**Output Today** and **Output Total**) of Meter 2 in the path of **Menu>History Data>E_USERDEF**.

NOTICE!

CT and Meter 1 cannot be used at the same time.

15.6 Application of Parallel Function

15.6.1 Introduction of Parallel Application

The series inverters supports parallel operation in both Grid and EPS modes. It can be configured with SolaX X3-PBOX-150kW-G2. Without X3-PBOX-150kW-G2, it supports up to 3 units in the parallel system, while with X3-PBOX-150kW-G2, it supports up to 10 units. Details are as follows:

Table 15-6 Maximum inverter number in parallel system

	X3-HYB-4.0-P	X3-HYB-5.0-P	X3-HYB-6.0-P	X3-HYB-8.0-P	X3-HYB-10.0-P	X3-HYB-12.0-P	X3-HYB-15.0-P
With X3-PBOX-150kW-G2	10	10	10	10	10	10	10
Without X3-PBOX-150kW-G2				3			

* Up to 10 inverters can be connected in parallel when there is no EPS connection.

15.6.2 Notice for Parallel Application

- All inverters should be of the same software version.
- For optimal efficiency, it is recommended that all inverters have the same model, and are connected to batteries of the same model and quantity.
- In parallel system, there are three status for devices: **Free**, **Slave** and **Master**.

Table 15-7 Status of devices in parallel system

Free	No one inverter is set to be the master inverter and all inverters are free.
Slave	Once one inverter is set as Master , all other inverters automatically become slave inverters. Its subordinate identity cannot be changed through the LCD.
Master	You can select one inverter and set it as Master , and then the master inverter dominates the parallel system. You can also change its identity into Free .

- Master inverter has an absolute lead in the parallel system to control all slave inverter's energy management and dispatch control. Once master inverter has some error and stop working, all slave inverters will be stop simultaneously. But master inverter is independent of all slave inverters to work and will not be affected by slave inverter's fault.

- Overall system will be running according to master inverter's setting parameters, and most setting parameters of slave inverter will be kept but not be cancelled.
- Once slave inverter exits from the system and be running as an independent unit (the network cable is disconnected simultaneously), its all setting will be re-activated.
- The parallel system is extremely complex and requires a large number of cables to be connected. Therefore, the cables must be connected in the correct wire sequence. Otherwise, any small mistake can lead to system failure.
- The communication cable length should not exceed 30 m.

15.6.3 System Wiring Diagram

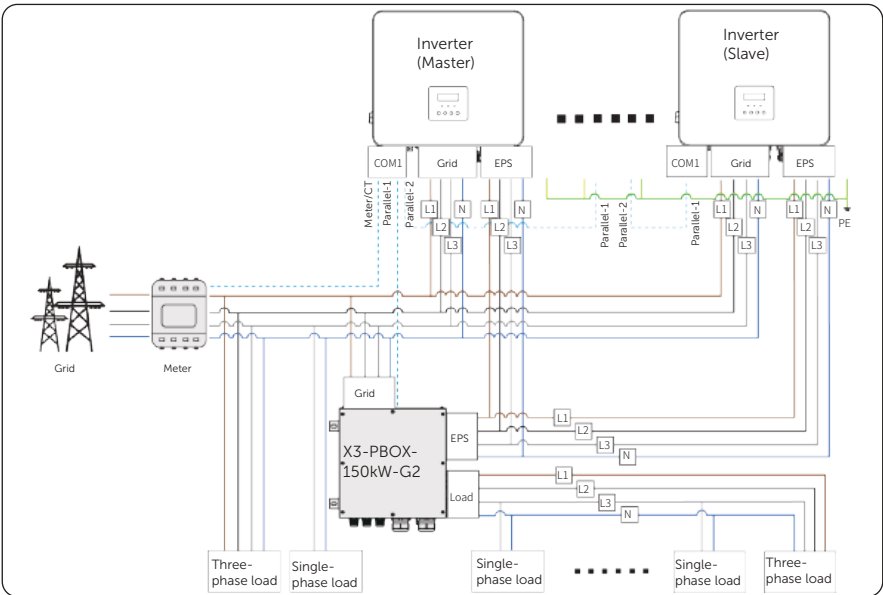

Figure 15-19 With X3-PBOX-150kW-G2 system wiring diagram

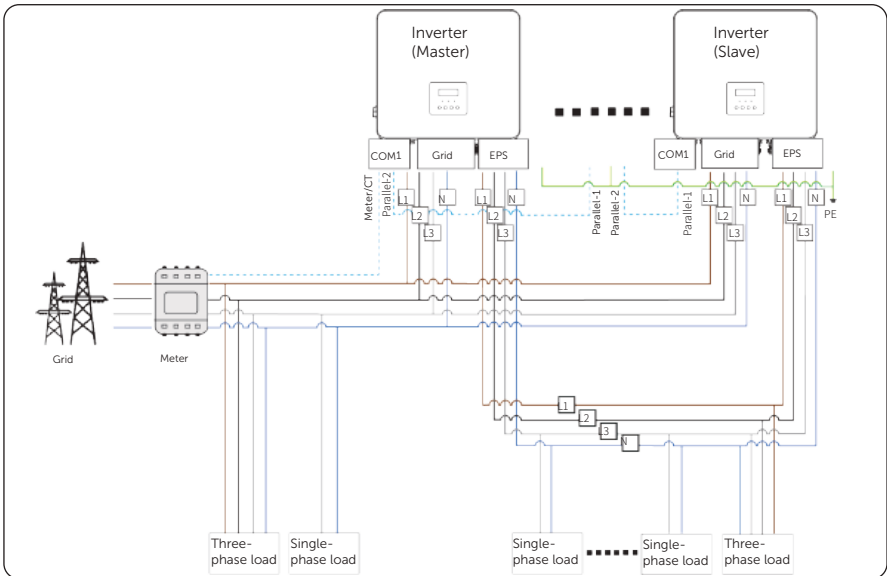

Figure 15-20 Without X3-PBOX-150kW-G2 system wiring diagram

15.6.4 System Wiring Procedure

Power cable wiring-Grid and EPS terminal

- With X3-PBOX-150kW-G2:
 - a. Connect the master inverter, slave inverters and Master-X3-PBOX-150kW-G2 with the five-core copper cable.
 - b. Grid terminal of the master, slave inverters and X3-PBOX-150kW-G2: L1 connects to L1, L2 connects to L2, L3 connects to L3 and N connects to N.
 - c. EPS terminal of the master, slave inverters and X3-PBOX-150kW-G2: L1 connects to L1, L2 connects to L2, L3 connects to L3 and N connects to N.
 - d. All PE cable connects to the same E-BAR nearby.

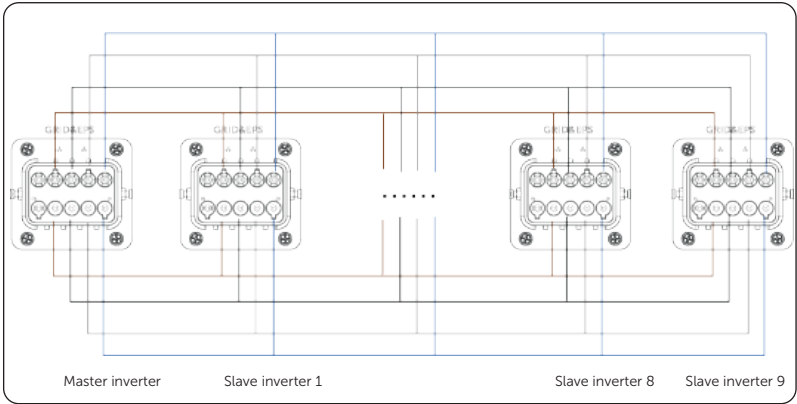

Figure 15-21 Power cable wiring with X3-PBOX-150kW-G2

- Without X3-PBOX-150kW-G2
 - a. Connect the master inverter and slave inverters with the five-core copper cable.
 - b. Grid terminal of the master inverter and slave inverters: L1 connects to L1, L2 connects to L2, L3 connects to L3 and N connects to N,
 - c. EPS terminal of the master inverter and slave inverters: L1 connects to L1, L2 connects to L2, L3 connects to L3 and N connects to N,
 - d. All PE cable connects to the same E-BAR nearby.

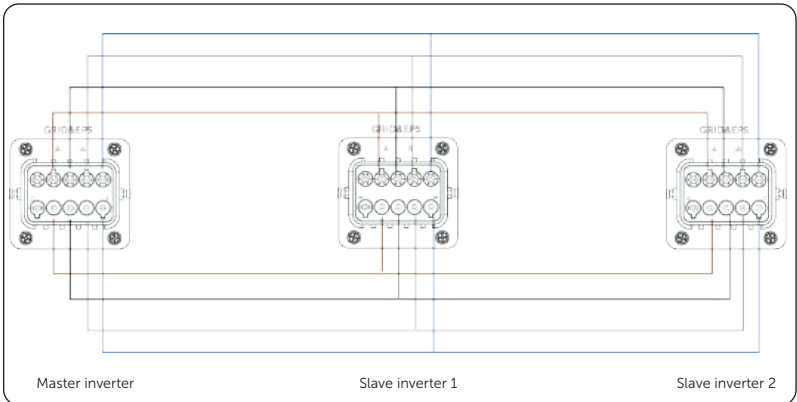

Figure 15-22 Power cable wiring without X3-PBOX-150kW-G2

Communication cable wiring-COM1 terminal

- With X3-PBOX-150kW-G2.
 - a. Connect the master inverter, slave inverters and X3-PBOX-150kW-G2 with a standard network cable.
 - b. Master inverter Parallel-1 connects to the COM terminal of X3-PBOX-150kW-G2.
 - c. Master inverter Parallel-2 connects to Slave 1 inverter Parallel-1;
 - d. Slave 1 Parallel-2 connects to Slave 2 Parallel-1; other inverters are connected in such way.
 - e. Meter connects to Meter/CT sub-terminal of the Master inverter. Please refer to ["8.6.1 Meter/CT Connection"](#).

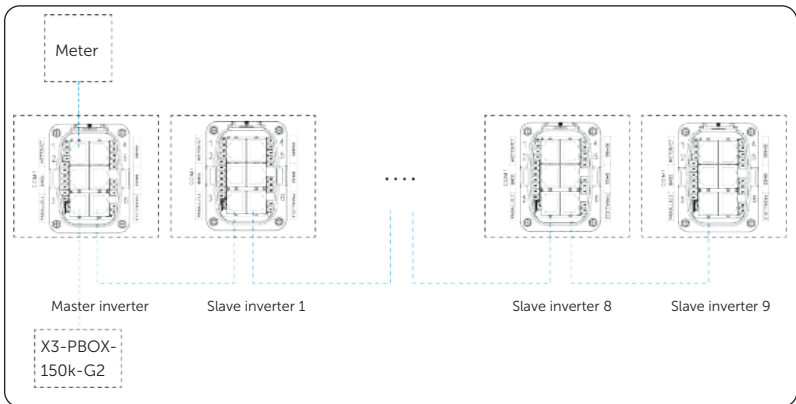

Figure 15-23 Communication wiring with X3-PBOX-150kW-G2

- Parallel connection without X3-PBOX-150kW-G2.
 - a. Connect the master inverter and slave inverters with a standard network cable.
 - b. Master inverter Parallel-2 connects to Slave 1 inverter Parallel-1.
 - c. Slave 1 inverter Parallel-2 connects to Slave 2 inverter Parallel-1.
 - d. Meter connects to Meter/CT sub-terminal of the Master inverter. Please refer to ["8.6.1 Meter/CT Connection"](#).

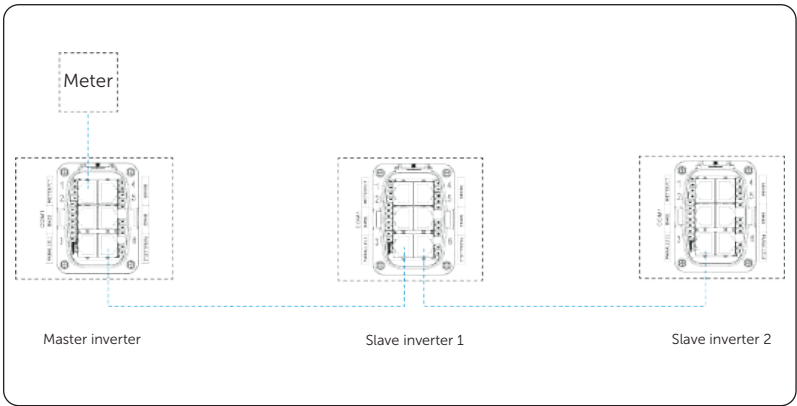

Figure 15-24 Communication wiring without X3-PBOX-150kW-G2

NOTICE!

- For details about the parallel connection of X3-PBOX-150kW-G2, refer to *X3-PBOX-150kW-G2 Installation Guide*.
- For details on the specific wiring of the inverter, refer to “8.3 AC Connection” and “8.6.4 Parallel Connection”.

15.6.5 Settings for Parallel Connection

Meter/CT setting

Setting path: **Menu>Settings>Advanced Settings>Meter/CT Settings**. For details, refer to "Meter/CT Settings".

Parallel setting

Setting path: **Menu>Settings>Advanced Settings>Parallel Settings**.

How to build the parallel connection

- Open the power supply for all inverters. Select an inverter and connect a meter to the inverter. Enter the LCD of the inverter and select **Menu>Settings>Advanced Settings>Parallel Settings**. Set the inverter as **Master** and set **Resistance Switch** to **ON**. If settings succeed, the other inverters automatically become slave inverters.



- Find the last slave inverter in the parallel system and set **Resistance Switch** to **ON**.

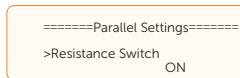

How to remove the parallel connection

- Find the inverter which needs to be set as Free. Select the **Parallel Settings** and select **Free** for the inverter.

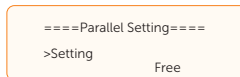

- Disconnect all the network cables on the Parallel-1 and Parallel-2 sub-terminals.

NOTICE!

- If a slave inverter is set to **Free** but not disconnect the network cable, this inverter will return to **Slave** automatically.
- If a slave inverter is disconnected with master inverter but not be set to **Free**, this slave inverter will stop working and prompt **ParallelFault**.

External ATS setting

Setting path: **Menu>Settings>Advanced Settings>Parallel Settings>External ATS**.

When a X3-PBOX-150K G2 is connected in the parallel system, you need to enable the function.

```
====External ATS====  
Function Control  
> Disable <
```

Parallel display

Displaying path: **Menu>Parallel Status**

NOTICE!

Once an inverter enters the parallel system, the **Today** yield will be replaced by **Parallel**.

In **Parallel Status** interface, the whole system power and individual slave inverter power can be obtained in **Parallel Status** interface of master inverter. The number displayed in the **Parallel Status** interface refers to the total number of online inverters, for example two inverters in parallel in the below figure.

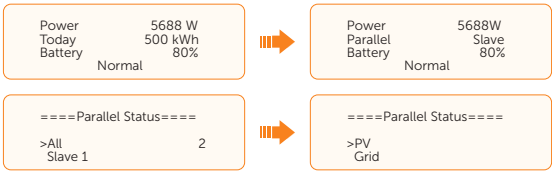

15.7 CT/Meter Connection Scenarios

X3-HYB G4 PRO inverter series can be connected to a single batch of CTs, a direct-connected meter, or a CT-connected meter, and also support a Meter 2 function for you to monitor another power generation device at home.

The following are the detailed wiring and setting procedures of these scenarios. For wiring procedure of the inverter CT/Meter terminal, see ["8.6.1 Meter/CT Connection"](#).

15.7.1 Connection of CT

NOTICE!

- Do not place the CT on the N wire or ground wire.
- Do not place CT on the N line and L line at the same time.
- Do not place the CT on non-insulated wires.
- The cable length between CT and inverter should not exceed 100 meters.
- After CT is connected, prevent the CT clip from falling off. It is recommended to wrap the CT clip around in circles with insulating tape.

NOTICE!

The CTs referred to in this section are the CT batch delivered with the inverter.

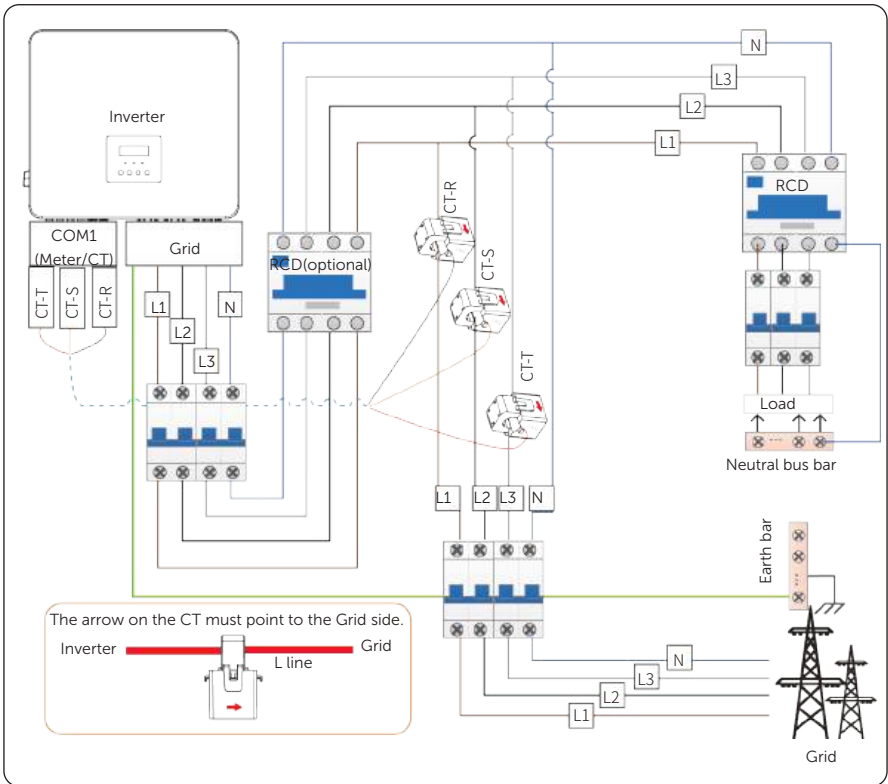

Figure 15-25 System wiring with CT

* The arrow on the CTs must point at the public grid.

*Markings on the CTs might be R, S and T or L1, L2 and L3. Make sure to clip CT-R/CT-L1 to the L1 wire, CT-S/CT-L2 to the L2 wire, and CT-T/CT-L3 to the L3 wire.

*The emergency load is connected to the EPS terminal of the inverter, which is not shown in the diagram.

Wiring Procedure

- Step 1:** Clip CT_R, CT_S and CT_T respectively onto the L1, L2 and L3 cables of the grid. Make sure the arrow on the CTs is pointing to the grid side from the inverter.

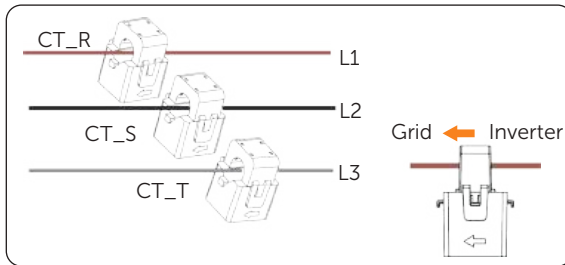

Figure 15-26 Clipping CTs to grid cables

- Step 2:** Use the RJ45 connector (part R) to connect the extension communication cable and a batch of CTs.

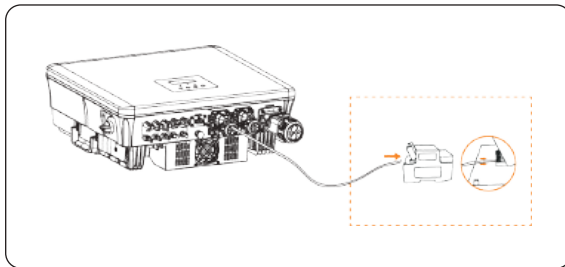

Figure 15-27 Connecting the inverter to the CT

Setting Procedure

After connecting CTs to the inverter, set parameters for them on the inverter.

- Step 1:** Select **Advanced Settings > Meter/CT Settings > CT**.

- Step 2:** Select the supported CT type.

You can check the connection status in **Meter/CT Check**. For details, see "[Meter/CT Settings](#)"



15.7.2 Connection of Direct-connected Meter

NOTICE!

SolaX DTSU666 is used as an example.

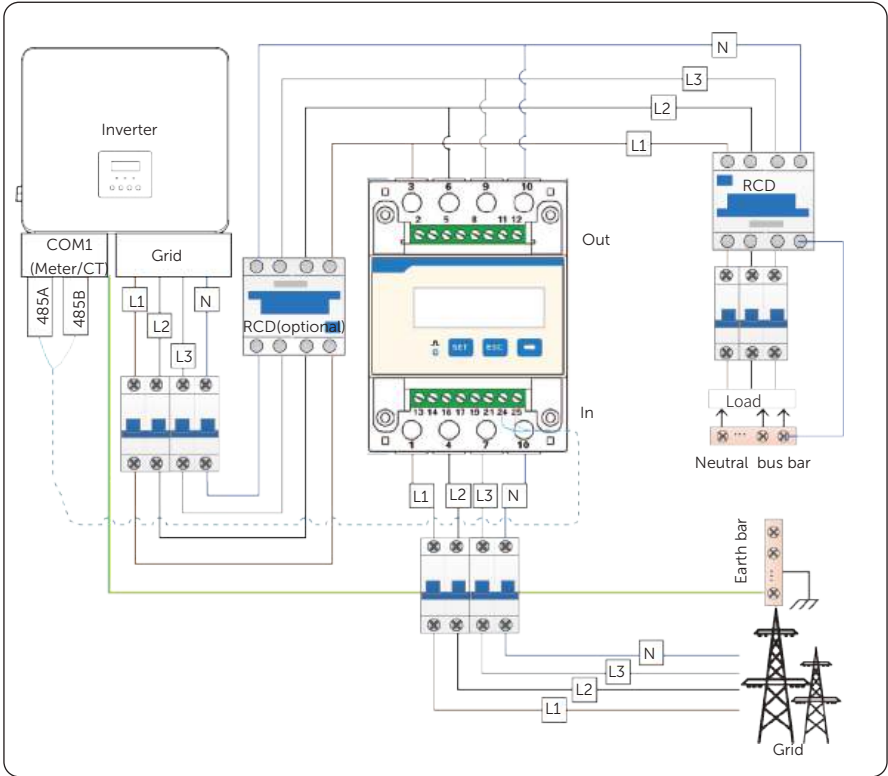

Figure 15-28 System wiring with direct-connected meter

*For direct-connected meter, the current flow direction should be from grid to the inverter.

*Terminals 1, 4 and 7 of the meter must be connected to the grid side, and terminals 3, 6 and 9 be connected to the inverter side of the system. Otherwise, the system power data might be misread.

Meter Terminal Definition

Table 15-1 Terminal definition of SolaX direct-connected meter

Terminal No.	Definition	Description
1, 4, 7	UA*, UB*, UC*	Voltage input terminal of phases A, B, and C, respectively connected to wires L1, L2 and L3
3, 6, 9	UA, UB, UC	Voltage output terminal of the three phases, respectively connected to wires L1, L2 and L3
10	UN	Connected to the N wire
24	RS485A	RS485 terminal A, connecting the communication wire from terminal METER_485 of the inverter
25	RS485B	RS485 terminal B, connecting the communication wire from terminal METER_485 of the inverter

Wiring Procedure

Step 1: Strip around 10 mm wire insulation off the grid voltage cables, and then connect L1, L2 and L3 wires respectively to terminal 1 and 3, 4 and 6, 7 and 9, and N wire to terminal 10 of the meter.

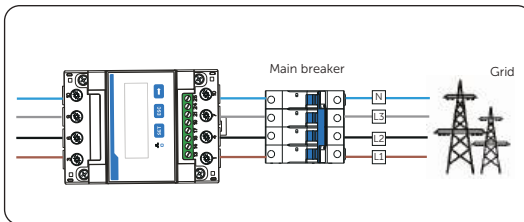

Figure 15-29 Connecting direct-connected meter to the grid

Step 2: Strip 15 mm wire insulation off the other end of the communication cable.

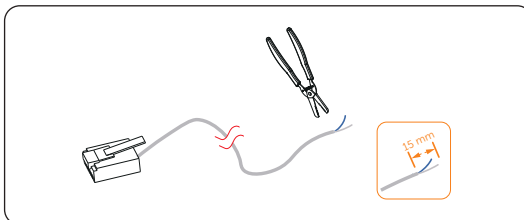

Figure 15-30 Stripping communication cable for meter

Step 3: Connect conductors 4 and 5 of the cable to terminals 24 and 25 of the meter.

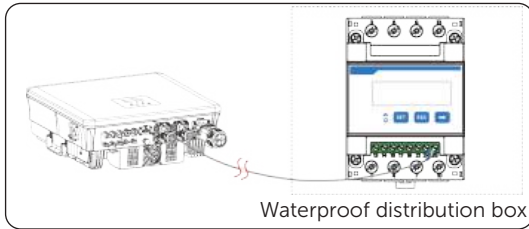

Figure 15-31 Connecting inverter to SolaX meter

Setting Procedure

After connecting the meter to the inverter, set parameters for it on the inverter.

Step 1: Select **Advanced Settings > Meter/CT Settings > Meter**.

Step 2: Set **Meter1Addr** to **1** and **Meter1 Direction** to **Positive**.

You can check the connection status in **Meter/CT Check**. For details, see "[Meter/CT Settings](#)".

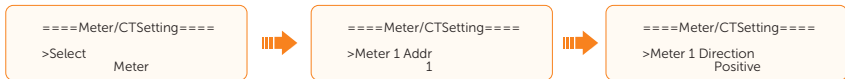

15.7.3 Connection of CT-connected Meter

NOTICE!

- SolaX DTSU666-CT is used as an example.
- The CTs referred to in this section are only CTs that are delivered with the CT-connected meter.

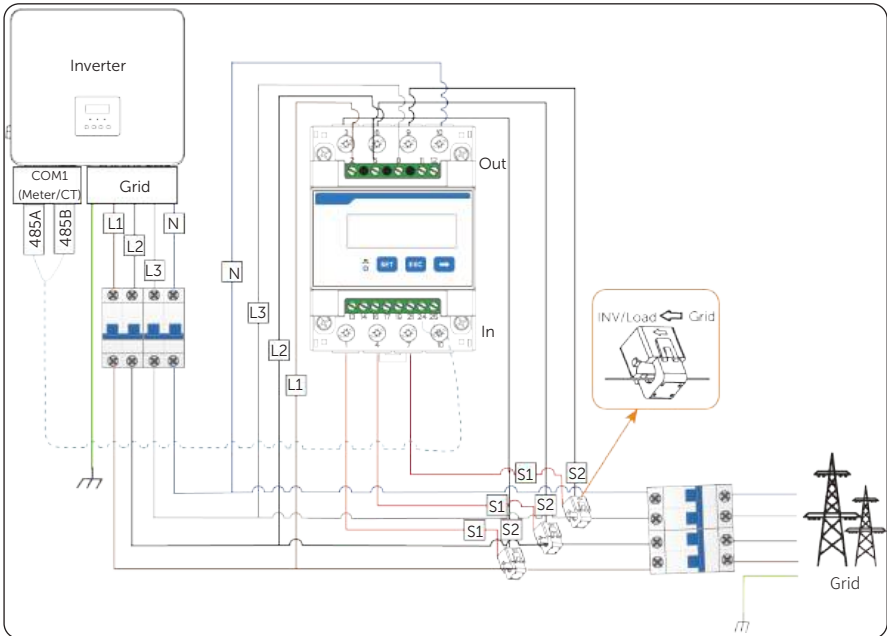

Figure 15-32 System wiring with SolaX CT-connected meter

*Terminal 2, 5 and 8 of the meter must be connected to the grid side. Terminal 1, 4 and 7 must be connected to the S1 wire of the CTs, and terminal 3, 6 and 9 be connected to the S2 wire of the CTs. Otherwise, the system power data might be misread.

*The arrow on the CTs must point at the inverter side.

Meter Terminal Definition

Table 15-2 Terminal definition of CT-connected meter

No.	Terminal No.	Definition	Description
A	2, 5, 8	UA, UB, UC	Voltage input terminal of phases A, B, and C, respectively connected to wires L1, L2 and L3
	10	UN	Connected to the N wire
B	1 / 4 / 7	IA*, IB*, IC*	Current input terminal of phases A, B, and C, connected to the S1 wire of CTs
	3 / 6 / 9	IA, IB, IC	Current output terminal of phases A, B, and C, connected to the S2 wire of CTs
C	24	RS485A	RS485 terminal A, connecting the communication wire from terminal METER_485 of the inverter
	25	RS485B	RS485 terminal B, connecting the communication wire from terminal METER_485 of the inverter

Wiring Procedure

- Step 1:** Strip about 10 mm wire insulation off the voltage cables, and then connect L1, L2 and L3 wires respectively to terminal 2, 5 and 8, and the N wire to terminal 10 of the meter.
- Step 2:** Clip the CTs onto the L1, L2 and L3 wires in the direction from grid to inverter.
- Step 3:** Connect the S1 wire of the three included CTs respectively to terminal 1, terminal 4 and terminal 7, and S2 wire of the CTs respectively to terminal 3, 6 and 9 of the meter.

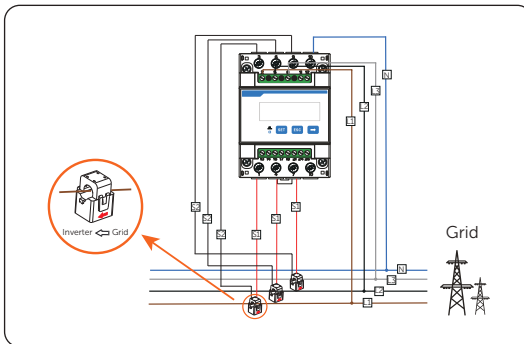

Figure 15-33 Connecting CT-connected meter to the grid

- Step 4:** Strip 15 mm wire insulation off the other end of the communication cable.

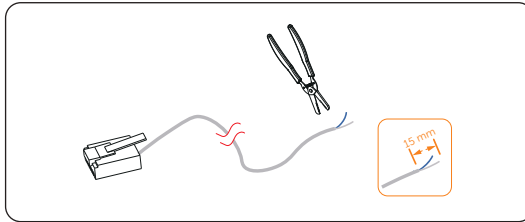

Figure 15-34 Stripping communication cable for meter

Step 5: Connect conductors 4 and 5 of the cable to terminals 24 and 25 of SolaX CT-connected meter.

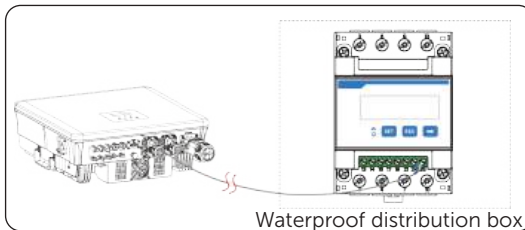

Figure 15-35 Connecting inverter to meter

Setting Procedure

After connecting the CT-connected meter to the inverter, set parameters for it on the inverter.

Step 1: Select **Advanced Settings > Meter/CT Settings > Meter**.

Step 2: Set **Meter1Addr** to **1** and **Meter1 Direction** to **Positive**.

You can check the connection status in **Meter/CT Check**. For details, see "[Meter/CT Settings](#)".

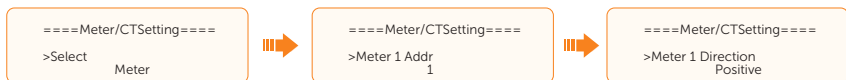

15.7.4 Connection of Two Meters

If you have two power generation devices (this inverter and the other one) and want to monitor both of them, this inverter provides Meter 2 communication function to help you achieve it.

NOTICE!

- For connecting CT and meter, or connecting two meters, prepare an RJ45 splitter adapter and a proper waterproof enclosure for it in advance.
- The device for monitoring the system (device at Meter 1 position) can be CT, direct-connected meter and CT-connected meter, but the device for monitoring another power generation device (device at Meter 2 position) can only be meters, either direct-connected meter or CT-connected meter. The following diagrams use the connection of CT and direct-connected meter for example.

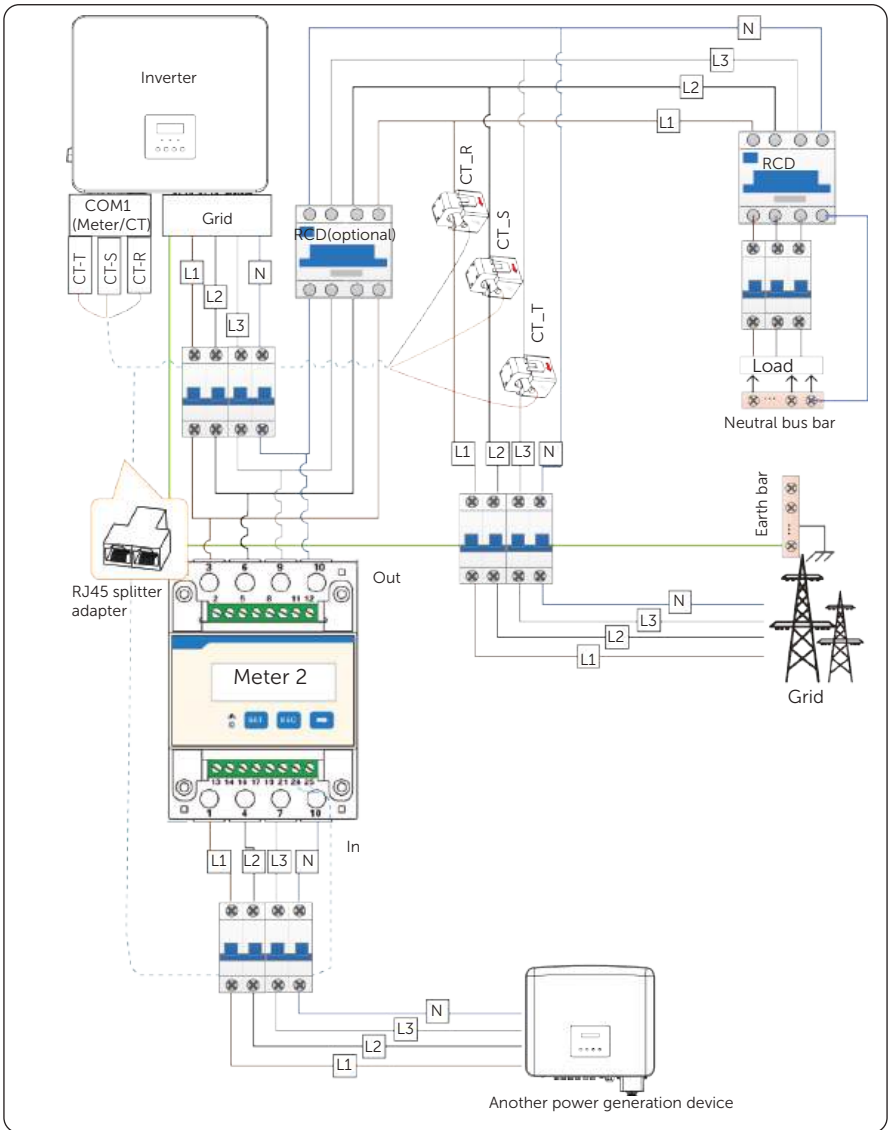

Figure 15-36 Connection diagram of CT and direct-connected meter

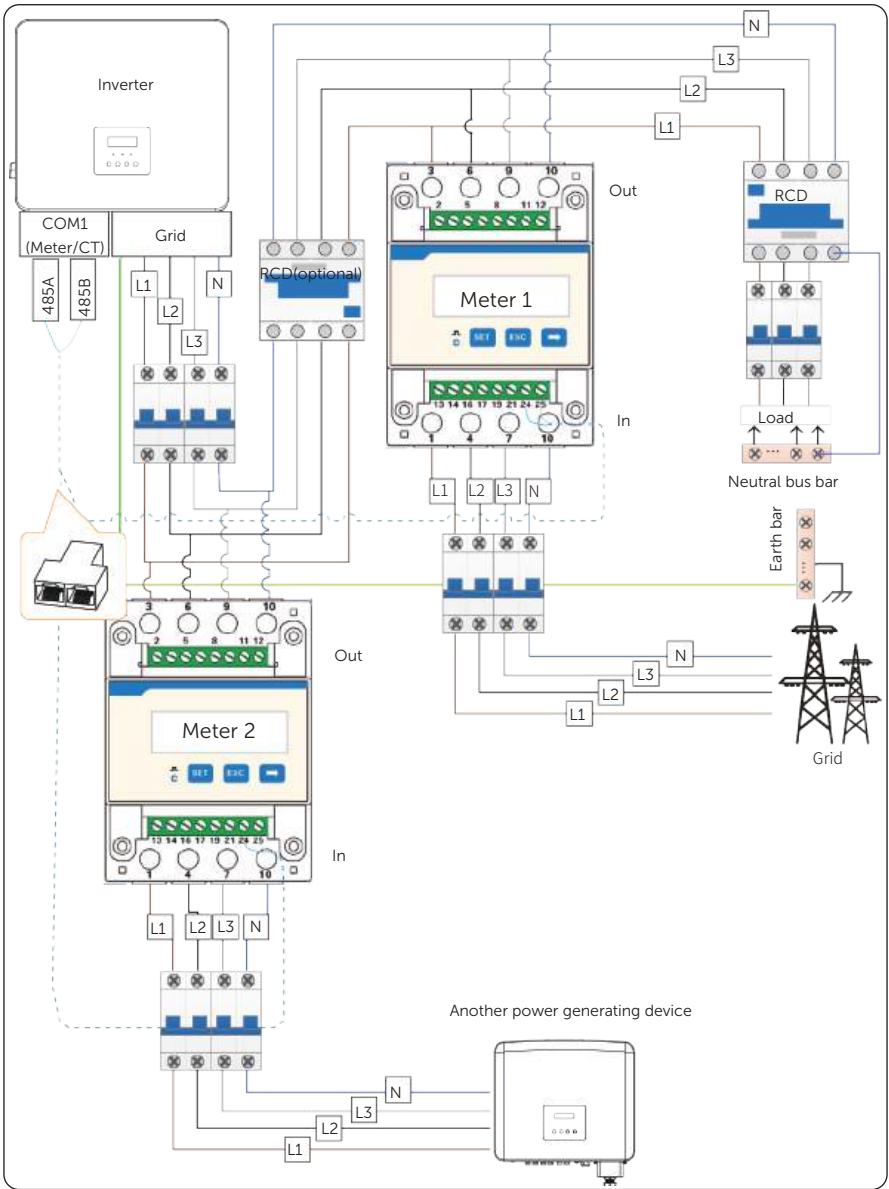

Figure 15-37 Connection diagram of two direct-connected meters

Wiring Procedure

Step 1: Follow the above steps to connect the meter, CT and inverter.

Step 2: Connect the RJ45 terminal to the RJ45 splitter adapter.

Setting Procedure

After connecting the CT and meter to the inverter, you need to set parameters on the inverter LCD before they can work normally for the system.

Step 1: Select **Advanced Settings > Meter/CT Settings**.

Step 2: Set the Meter/CT:

- » Case 1: CT and Meter 2 are connected (CT for SolaX inverter, Meter 2 for another power generation device). Select **CT** and set the CT type to 100 or 200 A according to the actual situations. Check whether the address and direction of Meter2 are set based on actual connection.

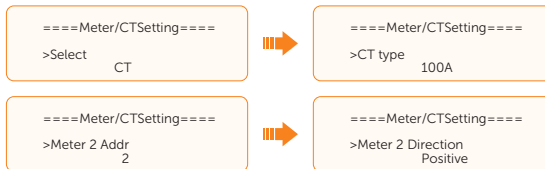

- » Case 2: Meter 1 and Meter 2 are connected (Meter 1 for SolaX inverter, Meter 2 for another power generation device). Select **Meter** and enable the Meter function. Check whether the address and direction of Meter 1 and Meter 2 are set based on actual connection.

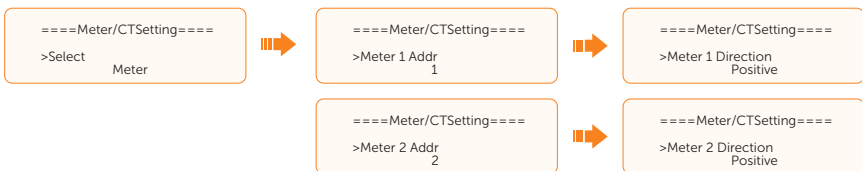



SolaX Power Network Technology (Zhejiang) Co., Ltd.

Add.: No. 278, Shizhu Road, Chengnan Sub-district, Tonglu County,
Hangzhou, Zhejiang, China
E-mail: info@solaxpower.com