

REV.	Description	REV.	Description
0.0	V0.0 首次发行 陈珍珍 2023/10/25		
1.0	1. 修改封面封底, 色号 2. 修改附件包描述方式 3. 删除 ukca 4. 修改 contact info 页 5. 增加端子注释说明 陈珍珍 2024/3/22		
2.0	1. 封底修改公司地址, 删去公司电话, 删去土耳其办公室电话 2. 删除 1.3 不能在阳光下储存或安装电池 3. 修改 4.1.1 修改安装环境图片 4. 302°F/60°C 改为 302°F/150°C 5. 删除 120months 相关质保说明 李杭钊 2024/8/2		
3.0	1. 增加第八章并机 2. 增加第九章匹配第三方逆变器 3. 修改报错代码 4. 修改澳洲邮箱 李杭钊 2024/10/31		
4.0	9.1.1 扩容模式增加拨码开关警告 李杭钊 2024/12/23		
5.0	增加禁止锂电做铅酸使用的免责声明 李杭钊 2025/2/17		

品名	说明书 T-BAT LR25(36) 英文版 SolaX 05 版			浙江艾罗网络能源技术股份有限公司 SolaX Power Network Technology (Zhejiang) Co., Ltd.	
料号	320101075905				
单位	mm				页次

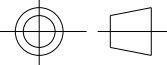
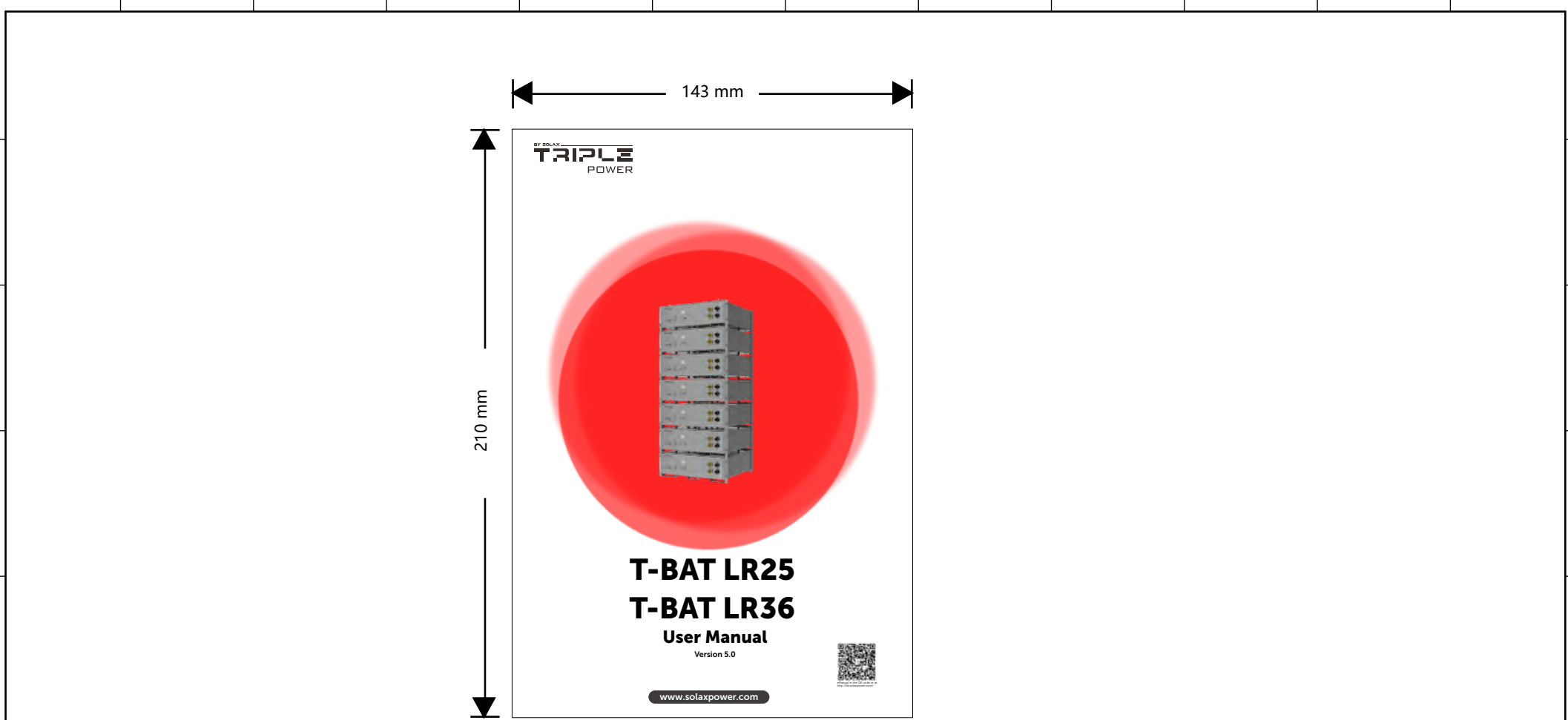

技术要求:

- 封面封底 157g 铜版纸覆哑膜彩打, 内部纸 80g 双胶纸黑白印刷, 正反打印;
- 装订方式: 胶装或骑马钉, 内页大于 60 页时须胶装;
- 未注尺寸公差按 ± 3 mm;
- 图面、字体印刷清晰、无偏移、无毛边、不起边、油墨不脱落;
- 黑色字体颜色为 PANTONE BLACK C, 无边框, 底色为白色;
- 符合 ROHS 要求。

品名	说明书 T-BAT LR25(36) 英文版 SolaX 05 版	设计	陈珍珍 2025/2/18
		审核	宋 苏 2025/2/18
材料	NA	核准	施鑫淼 2025/2/18
料号	320101075905	浙江艾罗网络能源技术股份有限公司	
单位	mm		



T-BAT LR25

T-BAT LR36

User Manual

Version 5.0

www.solaxpower.com



STATEMENT

Copyright

Copyright © SolaX Power Network Technology (Zhejiang) Co., Ltd. All rights reserved.

No part of this manual may be reproduced, transmitted, transcribed, stored in a retrieval system, or translated into any language or computer language, in any form or by any means without the prior written permission of SolaX Power Network Technology (Zhejiang) Co., Ltd.

Trademarks



POWER and other symbol or design (brand name, logo) that distinguishes the products or services offered by SolaX has been trademark protected. Any unauthorized use of above stated trademark may infringe the trademark right.

Notice

All or part(s) of the products, features and services described in this document may not be within your scope of purchase or usage. Unless otherwise specified in the contract, the contents, information and recommendations in this document are provided as is, SolaX makes no kind of warranties, guarantees or representations expressly or implicitly.

The content of the documents is continually reviewed and amended, where necessary. However, discrepancies cannot be excluded. SolaX reserves the right to make improvements or changes in the product(s) and the program(s) described in this manual at any time without the prior notice.

The images contained in this document are for illustrative purposes only and may vary depending on product models.

Please visit the website www.solaxpower.com of SolaX Power Network Technology (Zhejiang) Co., Ltd. for more information.

SolaX reserves all the right for the final explanation.

About This Manual

Scope of Validity

This manual is an integral part of T-BAT Series. It describes the installation, electrical connection, commissioning, maintenance and troubleshooting of the product. Please read it carefully before operating.

Battery Module
T-BAT LR25
T-BAT LR36

Note:

In the case of rack or cabinet installation, the whole battery system contains battery module(s) and rack (or cabinet). In the case of wall mounting, it contains battery module(s) only. For details, please refer to the Chapter 13 ["Technical Data"](#).





Target Group

The installation and maintenance can only be performed by qualified personnel who

- Are licensed and/or satisfy state and local jurisdiction regulations.
- Have good knowledge of this manual and other related documents.

Conventions

The symbols that may be found in this manual are defined as follows.

Symbol	Description
 DANGER	Indicates a hazardous situation which, if not avoided, will result in death or serious injury.
 WARNING	Indicates a hazardous situation which, if not avoided, could result in death or serious injury.
 CAUTION!	Indicates a hazardous situation which, if not avoided, could result in minor or moderate injury.
 NOTICE!	Provides tips for the optimal operation of the product.

Change History

Version 05 (2025-02-18)

Updated "[1.3 Battery Handling Guide](#)" (Added prohibition of using battery in lead-acid mode)

Version 04 (2024-12-23)

Updated "[9.1.1 Connection of Capacity Expansion](#)" (Added the warning of the DIP switch)

Version 03 (2024-10-28)

Added "[8 Parallel Connection](#)"

Added "[9 Connection to the Third-party Inverter](#)"

Updated "[10.2 Troubleshooting](#)" (Altered error code)

Updated "[Contact Information](#)" (Altered the Australia e-mail)

Version 02 (2024-08-02)

Updated "[1.3 Battery Handling Guide](#)"

Updated "[4.1.1 Environment Equipment](#)"

Updated the "[Back Cover](#)" (Deleted the company website)

Updated temperature (Altered 302°F/60°C to 302°F/150°C)

Updated warranty claim (Deleted 120 months warranty claim)

Version 01 (2024-03-22)

Updated "[2.2.4 Symbols on the Label](#)" (Deleted UKCA icon)

Version 00 (2023-10-25)

Initial release

Table of Contents

- 1 Safety 1
 - 1.1 General Safety 1
 - 1.2 General Safety Precautions 2
 - 1.3 Battery Handling Guide..... 2
 - 1.4 Response to Emergency Situations..... 3
- 2 Product Overview 5
 - 2.1 System Description 5
 - 2.2 Appearance 5
 - 2.2.1 Weight and Dimensions 6
 - 2.2.2 Battery Module (T-BAT LR25/ T-BAT LR36)..... 8
 - 2.2.3 Indicators 10
 - 2.2.4 Symbols on the Label 13
 - 2.3 Features 14
 - 2.4 Certifications..... 14
- 3 Transportation and Storage 15
- 4 Preparation before Installation..... 16
 - 4.1 Selection of Installation Location 16
 - 4.1.1 Environment Requirement 16
 - 4.1.2 Installation Carrier Requirement..... 17
 - 4.1.3 Clearance Requirement 18
 - 4.2 Tools Requirement..... 20
 - 4.3 Additionally Required Materials 20
- 5 Unpacking and Inspection 21
 - 5.1 Unpacking..... 22
 - 5.2 Scope of Delivery..... 23
- 6 Mechanical Installation 27
 - 6.1 Installation Options 27
 - 6.2 Installation Procedure 28
 - 6.2.1 Installation Procedure with Rack 29
 - 6.2.2 Installation Procedure with Cabinet 34
 - 6.2.3 Wall Mounting 42
- 7 Wiring..... 48
 - 7.1 PE Connection 48

7.2	Communication Connection (connecting to inverter)	50
7.3	Details of Cables	51
7.4	Wiring Procedure	53
7.4.1	Wiring Procedure about Rack Installation	53
7.4.2	Wiring Procedure about Cabinet Installation	57
7.4.3	Wiring Procedure about Wall Mounting	62
8	Parallel Connection	66
8.1	Wiring of Parallel Connection	66
8.2	Materials Requirement	67
9	Connection to the Third-party Inverter	68
9.1	Cable Connection	68
9.1.1	Connection of Capacity Expansion	68
9.1.2	Connection of Power Expansion	69
9.2	Powering-on of the Third-party Inverter	69
10	System Commissioning	70
10.1	Checking before Power-on	70
10.2	Powering on the System	70
11	Troubleshooting and Maintenance	72
11.1	Power off the System	72
11.2	Troubleshooting	73
11.3	Maintenance	77
12	Decommissioning	78
12.1	Disassembling the Battery	78
12.2	Packing	80
12.3	Disposing of the Rechargeable Battery	80
13	Technical Data	81

1 Safety

1.1 General Safety

The series rechargeable battery is well designed and tested to meet all applicable states and international safety standards. However, like all electrical and electronic equipment, safety precautions must be observed and followed during the installation of the rechargeable battery to reduce the risk of personal injury and to ensure a safe installation.

Before installing the device, carefully read, fully understand and strictly follow the detailed instruction of the *User Manual* and other related regulations. And the safety instructions in this document are only supplements to local laws and regulations.

SolaX shall not be liable for any consequences caused by the violation of the storage, transportation, installation, and operation regulations specified in this document, including, but not limited to:

- Rechargeable battery damage due to force majeure, such as earthquake, flooding, thunderstorm, lighting, fire hazard, volcanic eruption, overvoltage, etc.
- Rechargeable battery damage due to man-made cause
- Rechargeable battery used or operated against any items in local policy
- Failure to follow the operation instructions and safety precautions on the product and in this document
- Installation and use under improper environment or electrical condition
- Unauthorized modifications to the product or software
- Rechargeable battery damage caused during transportation by the customer
- Storage conditions that do not meet the requirements specified in this document
- Failure to adequately maintain the equipment.
- Use of incompatible inverters or devices
- Installation and commissioning operated by unauthorized personnel who are not licensed and /or satisfy state and local jurisdiction regulations.

1.2 General Safety Precautions

- Overvoltage or wrong wiring may damage the battery module and cause combustion which may be extremely dangerous;
- Leakage of electrolytes or flammable gas may be occurred due to any type of product breakdown;
- Do not install the battery module in places where flammable and combustible materials are stored, and in which an explosive atmosphere is present;
- The battery module wiring must be carried out by qualified personnel;
- Battery module must be serviced by qualified personal;
- Ensure that the grounding cable is connected before handling the battery module.

1.3 Battery Handling Guide

Do's

- DO keep the battery module away from flammables materials, heat sources, and water sources;
- DO keep the battery module out of reach of children and animals;
- DO practice proper battery storage by keeping the battery module in a clean environment, free of dust, dirt and debris;
- DO store the battery module in a cool and dry place;
- DO seal the outer cable connection hole to prevent ingress of foreign objects;
- DO confirm that the wiring of the device must be correct;
- DO install the device according to the local standards and regulations.

Don'ts

- DON'T use SolaX lithium battery in Lead-acid mode. Lead-acid mode not only reduce the lifespan of lithium batteries, but may also cause safety issues under extreme conditions. Any consequences arising from the use of lead-acid mode shall be borne by users themselves, and SolaX will not provide warranty!
- DON'T expose the battery module to an open flame, or the temperature in excess of 140°F/60°C;
- DON'T install or operate the battery module in places where there is excessive moisture or liquids;
- DON'T place the battery module in a high-voltage environment;
- DON'T disconnect, disassemble or repair the device by unqualified personnel.

Only a qualified personnel is allowed to handle, install and repair the device;

- DON'T damage the device by dropping, deforming, impacting, cutting or penetrating with a sharp object. Otherwise, it may cause a fire or leakage of electrolytes;
- DON'T touch the device if liquid spill on it. There is a risk of electric shock;
- DON'T step on the packaging or the device may be damaged;
- DON'T place any objects on top of the battery module;
- DON'T charge or discharge a damaged battery module;
- DON'T dispose of the battery module in a fire. It may cause leakage or rupture;
- DON'T mix different types or makes of the battery module. It may cause leakage or rupture, resulting in personal injury or property damage.

1.4 Response to Emergency Situations

In case the battery module leaks electrolyte or any other chemical materials, or gas may be generated due to the leakage of battery module, be sure to avoid contact with the discharge at all times. In case of accidentally coming into contact with them, please do as follows:

- In case of inhalation: Leave the contaminated area immediately, and seek medical attention at once;
- In case of contact with eyes: Rinse eyes with running water for 15 minutes, and seek medical attention;
- In case of contact with skin: Wash the contacted area thoroughly with soap, and seek medical attention;
- In case of ingestion: Induce vomiting, and seek medical attention.

If a fire breaks out where the battery module is installed, please do as follows:

- In case the battery module is charging when the fire breaks out, provide it is safe to do so, disconnect the battery module circuit break to shut off the power charge;
- In case the device is not on fire yet, use a Class ABC fire extinguisher or a carbon dioxide extinguisher to extinguish the fire;
- If the battery module catches fire, do not try to put out the fire, and evacuate immediately.
- The battery module may catch fire when it is heated above 302°F/150°C; and in case of catching fire, it will produce noxious and poisonous gas, DO not approach and keep away.

Effective ways to deal with accidents

- In case of the damaged battery module, place it into a segregated place, and call the local fire department at the place where the user lives or qualified personnel.
- If any part of the battery module, or wiring is submerged, DO stay out of the water and DON'T touch anything; If the battery module gets wet, DON'T touch it.
- If the battery module is damaged, DON'T use it. Otherwise, it may result in both personal injury and property damage.
- DON'T use the submerged battery module again, and contact the qualified personnel for assistance.
- DO contact SolaX immediately for assistance if the user suspects that the battery module is damaged.

WARNING!

- Do not crush or impact battery, and always dispose of it according to relevant safety regulations.
- The battery module may catch fire when heated above 150°C/302°F.
- In case of catching fire, the battery module will produce noxious and poisonous gases, and please keep away the battery.
- Damaged batteries may leak electrolyte or produce flammable gas. If users suspect that the battery is damaged, please immediately contact SolaX for advice and information.
- All operations of T-BAT SYS-LR relating to electrical connection and installation must be carried out by qualified personnel.

CAUTION!

- If the battery module is not installed within a month after receipt, it must be charged for maintenance. Non-operational batteries should be discarded according to the local regulations.

2 Product Overview

2.1 System Description

A battery module is a type of electrical battery which can charge or discharge loads.

There are three installation options, such as rack installation, cabinet installation, and floor mounting, that a user can select from.

2.2 Appearance

Even if the silkscreen on different models of battery modules (T-BAT LR25 and T-BAT LR36) is different, the final installation effect drawing is the same.

The following figure takes the rack installation as an example.

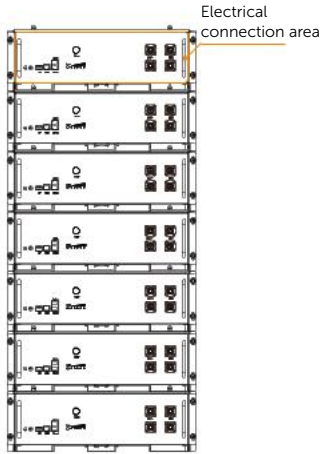

Figure 2-1 Appearance

Table 2-1 Description of appearance

Item	Description
Electrical connection area	Including BAT+/BAT- ports, communication port, BMS port, grounding port. Please refer to for details.

2.2.1 Weight and Dimensions

Table 2-2 Weight and Dimension of Battery Module

	Battery Module (T-BAT LR25)	Battery Module (T-BAT LR36)
Length (mm)	442.00	442.00
Width (mm)	430.00	430.00
Height (mm)	130.00	130.00
Net weight (kg)	28.00	32.00

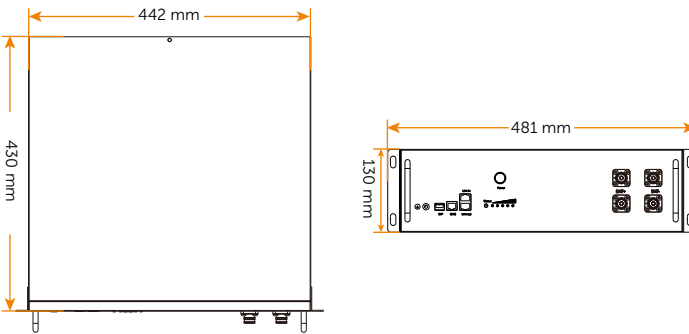

Figure 2-2 Dimension: Battery module (T-BAT LR25/ T-BAT LR36)

Table 2-3 Weight and Dimension of Rack and Cabinet

	Rack			Cabinet	
	Front Support	Rear Support	Metal Plate	22U	42U
Length (mm)	481.00	448.00	426.50	600.00	600.00
Width (mm)	32.00	32.00	34.00	600.00	600.00
Height (mm)	153.50	153.50	8.00	1161.00	2050.00
Net weight (kg)	(In total) 1.8			/	/
Remark	1U = 4.445 cm				

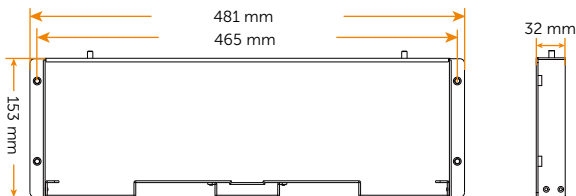

Figure 2-3 Dimension: Front support

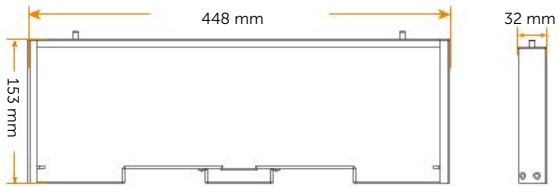

Figure 2-4 Dimension: Rear support

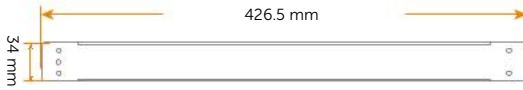

Figure 2-5 Dimension: Metal plate

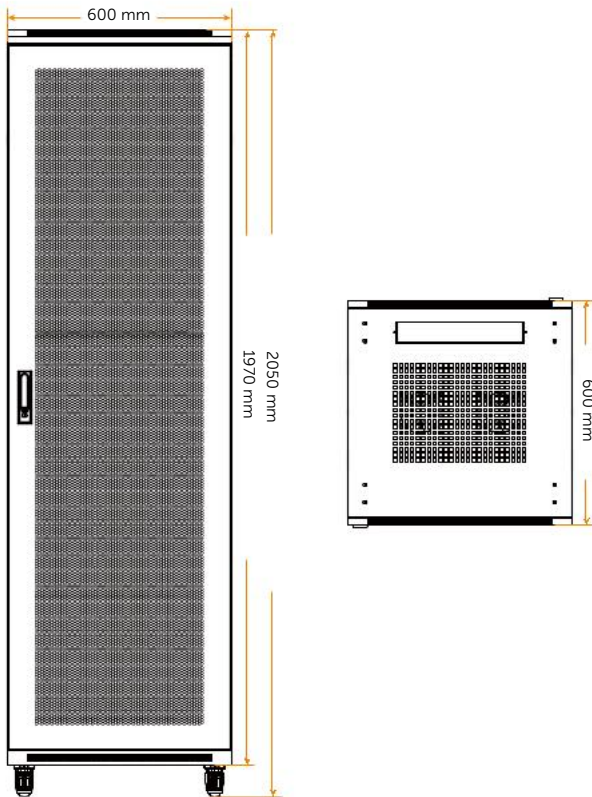

Figure 2-6 Dimension: Cabinet

2.2.2 Battery Module (T-BAT LR25/ T-BAT LR36)

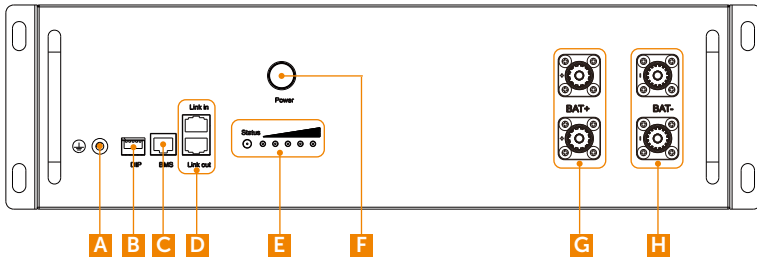

Figure 2-7 Battery module (T-BAT LR25/ T-BAT LR36)

Table 2-4 Description of ports and keys

Item	Description
A	Grounding port: Connect to the grounding port of the battery module or BMS.
B	"DIP Switch" : Realize battery's parallel function (a reserved function).
C	BMS port: Connect to the BMS port on the inverter.
D	Link in port: Connect to the "Link out" port of the neighbouring battery module (if any), or it doesn't need to be connected. Link out port: Connect to the "Link in" port of the neighbouring battery module (if any), or it doesn't need to be connected.
E	"Indicators" : A light that prompts the user to the status of the device.
F	Power button: Start/shut down system.
G	BAT+ port: Connect to the BAT+ port of the inverter. These two terminals' function is the same.
H	BAT- port: Connect to the BAT- port of the inverter. These two terminals' function is the same.

DIP Switch

A DIP Switch is actually a set of small manual electronic switches that are designed to be packaged with other circuits. It is currently equipped with the battery module.

The location of the DIP switch and the factory defaults are shown as below.

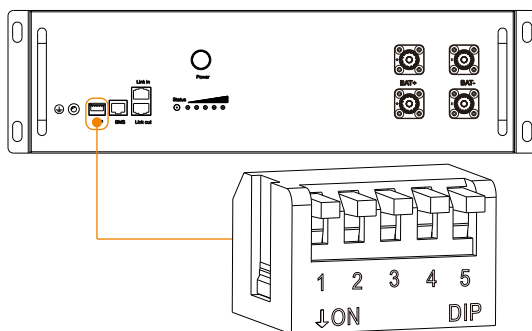

Figure 2-8 DIP Switch

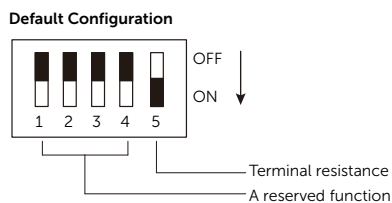

Figure 2-9 Default configuration

NOTICE!

- In the case of one tower, there is only one master battery module (always the uppermost battery module). While the master battery module connects to the inverter, **please confirm that the DIP switch 5 must stay in the ON position**, as well as the DIP switch 5 on the rest of the battery modules in the ON positions. Usually, the DIP switch 5 will be slid to the ON position in the factory settings.
- In the case of more than two towers, except that the master battery module (always the uppermost battery module) of the last tower shall be slid to the ON position, the Dip switch 5 on the rest of the master battery modules shall be flipped up to the OFF positions. Regarding the Dip switch 5 on the rest of the battery modules, please confirm that they are in the ON positions. Usually, the DIP switch 5 will be slid to the ON position in the factory settings.
- To adjust the DIP switch, a small flat-head screwdriver should be prepared by the users themselves. **Do not use a pencil.** Graphite from the pencil is conductive and may damage the DIP switch.

2.2.3 Indicators

The power indicators show the current battery percentage. There are six indicators on the battery module, one status light and five SOC power indicators.

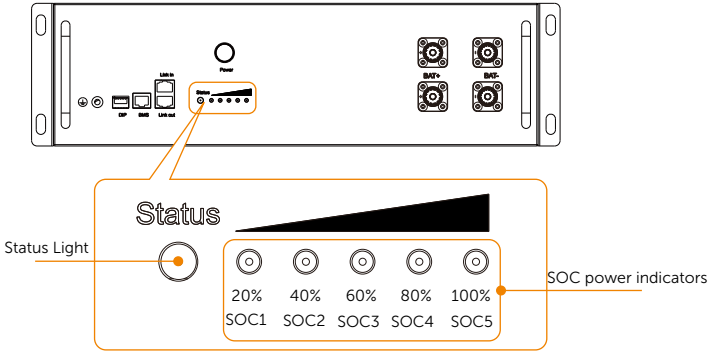

Figure 2-10 Indicators

Table 2-5 Definition of indicators

Status	Description
Start up	After pressing and holding the POWER button for more than 1 second, the function "Self Test" will be performed. When the Self Test is completed successfully, the status light will flash green light, and the SOC power indicators will remain on solid yellow light.
Shut down	After pressing and holding the POWER button for more than 3 seconds, the status light will remain on solid yellow light, and the SOC power indicators will remain on solid yellow light, and then all indicators are off.
Standby	The status light will come on green light. At the meantime, the SOC power indicators will come on solid yellow light.
Charging	The status light will flash green light every 1 second. Regarding the SOC power indicators, please refer to "Indicator information while charging" .
Discharging	The status light will flash green light every 1 second. Regarding the SOC power indicators, please refer to "Indicator information while discharging" .
Fault	In the case of failure, the status light will flash red light every 3 seconds. At the meantime, the SOC power indicators will remain on solid yellow light.
Black Start	For details, please refer to "Black Start" .

NOTICE!

- The function of **Self Test** will be performed when users turn the system on, with a duration of 10 seconds. In the meantime, the status light will remain on solid yellow light, and the SOC power indicators will remain on solid yellow light based on their actual remaining capacity.

Table 2-6 Indicator information while charging

SOC value	Status light	SOC1	SOC2	SOC3	SOC4	SOC5
0% = SOC	Flashing green light	Light off	Light off	Light off	Light off	Light off
0% < SOC < 20%	Flashing green light	Flash	Light off	Light off	Light off	Light off
20% ≤ SOC < 40%	Flashing green light	Flash	Flash	Light off	Light off	Light off
40% ≤ SOC < 60%	Flashing green light	Flash	Flash	Flash	Light off	Light off
60% ≤ SOC < 80%	Flashing green light	Flash	Flash	Flash	Flash	Light off
80% ≤ SOC ≤ 100%	Flashing green light	Flash	Flash	Flash	Flash	Flash

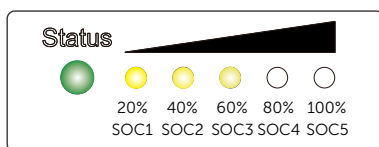

Figure 2-11 Charging

If the battery level is at 60%, the SOC power indicators will show as follows:

- The first three SOC power indicators (SOC1, SOC2 and SOC3) will flash yellow light every 1 second;
- The remaining SOC power indicators (SOC4 and SOC5) will be off.

Table 2-7 Indicator information while discharging

SOC value	Status light	SOC1	SOC2	SOC3	SOC4	SOC5
SOC ≥ 80%	Flashing green light	Light on	Light on	Light on	Light on	Light on
SOC ≥ 60%	Flashing green light	Light on	Light on	Light on	Light on	Light off
SOC ≥ 40%	Flashing green light	Light on	Light on	Light on	Light off	Light off
SOC ≥ 20%	Flashing green light	Light on	Light on	Light off	Light off	Light off
SOC ≥ 0%	Flashing green light	Light on	Light off	Light off	Light off	Light off

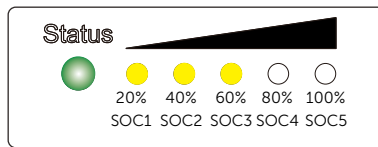

Figure 2-12 Discharging

If the battery level is at 60%, the SOC power indicators will show as follows:

- The first three SOC power indicators (SOC1, SOC2, and SOC3) will remain on solid yellow light;
- The remaining SOC power indicators (SOC4 and SOC5) will be off.













Black Start

The equipment can provide **Black Start** capacity, meaning that our energy storage inverter and battery can continue to run even if the power grid and photovoltaic panel are out of service. The startup procedure for **Black Start** is as follows:

- First stage: in case of pressing and holding the **POWER** button for less than 15 seconds, the status light will come on solid yellow light in the first 11 seconds and then turn to solid green light in the last 4 seconds, and the SOC power indicators will come on solid yellow light based on the actual remaining capacity.
- Second stage: after pressing and holding the **POWER** button for more than 15 seconds, the status light will flash yellow light every 1 second, and all the SOC power indicators will remain on solid yellow light based on the actual remaining capacity.
- Finally, release the **POWER** button.

2.2.4 Symbols on the Label

Table 2-8 Description of symbols

Symbol	Description
	CE mark. The rechargeable battery complies with the requirements of the applicable CE guidelines.
	TUV certified.
	RCM certified.
	The battery system must be disposed of at a proper facility for environmentally-safe recycling.
	The battery module may explode. The rechargeable battery can become hot during operation. Avoid contact during operation.
	Danger of high voltages. Danger to life due to high voltages in the rechargeable battery!
	Danger. Risk of electric shock!
	Observe enclosed documentation.
	The rechargeable can not be disposed together with the household waste.
	The rechargeable can not be disposed together with the household waste.
	Keep the battery system away from children.
	Keep the battery system away from open flames or ignition sources.

2.3 Features

The T-BAT SYS-LR is one of the most advanced energy storage systems on the market today, using state-of-the-art technology, and having the characteristics of high reliability and convenient control. Characteristics are shown as follows:

- 90% DOD;
- 95% Battery Round-trip Efficiency;
- Cycle Life > 6000 Cycles;
- Secondary Protection;
- IP20 Protection Level and Protection Class I;
- Safety & Reliability;
- Small Occupied Area;
- Floor Mounting and wall mounting.

2.4 Certifications

BAT system safety	CE, RCM, IEC 62619, IEC 63056, IEC 62620, IEC 62477-1, IEC 60730 Annex H, IEC 62040, VDE-AR-E2510, IEC 60529, UN38.3
UN number	UN 3480
Hazardous materials classification	Class 9
UN transportation testing requirements	UN 38.3
International protection marking	IP20, Protection Class I

3 Transportation and Storage

If the rechargeable battery are not put into use immediately, the transportation and storage requirements needs to be met:

Transportation

- Observe the caution signs on the packaging of battery before transportation.
- Pay attention to the weight of the rechargeable battery. Be cautious to avoid injury when carrying battery module (T-BAT LR25) (net weight: 28 KG) or battery module (T-BAT LR36) (net weight: 31 KG). Two installers are recommended.
- Wear protective gloves when carrying the equipment by hand to prevent injuries.
- When lifting up the rechargeable battery, hold the handle position and the bottom position of the battery. Keep the rechargeable battery horizontal in case of falling down due to tilt.

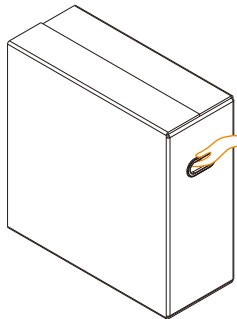

Figure 3-1 Handle position of carton

Storage

- Do not remove the original packaging material and check the outer packaging material regularly.
- The required storage temperature: the service life may be up to 6 months in case the temperature is between 30°C and +50°C, or it may be up to 12 months in case the temperature is between -20°C and +30°C. The relative humidity should be between 5% and 95%.
- Stack the battery in accordance with the caution signs on the battery carton to prevent their falling down and device damage. Do not place it upside down.
- If the rechargeable battery has been stored for more than 1 year, it must be checked and tested by professionals before use.

4 Preparation before Installation

4.1 Selection of Installation Location

The installation location selected for the rechargeable battery is quite critical in the aspect of the guarantee of machine safety, service life and performance.

- It has the IP20 ingress protection, which do not allow it to be installed outdoor;
- The installation position shall be convenient for wiring connection, operation and maintenance.

4.1.1 Environment Requirement

Make sure the installation site meets the following conditions:

- The operating temperature: -20°C to $+55^{\circ}\text{C}$;
- The humidity shall be between 5-95%;
- Do not install the rechargeable battery in the areas where the altitude exceeds 3000 m;
- Install the rechargeable battery in a well-ventilated environment for heat dissipation;
- Do not install the rechargeable battery in areas with flammable, explosive and corrosive materials;
- Do not install the rechargeable battery in areas near combustibles and antenna
- You are recommended to install an awning over it.

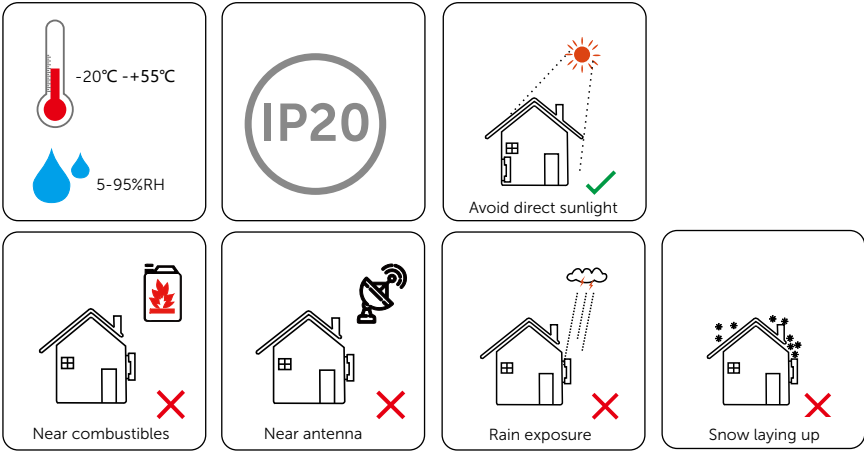
**NOTICE!**

- Exposure to direct sunlight raises the temperature inside the battery. This temperature rise poses no safety risks, but may impact the battery performance.

4.1.2 Installation Carrier Requirement

The mounting location must be suitable for the weight and dimensions of the product and the support surface for installation must be made of a non-flammable material.

- Solid brick/concrete;
- In the case of rack installation, please ensure that the bearing capacity of the supporting surface for the system must be over 800 kg (it is calculated based on the 7 battery modules);
- In the case of cabinet installation, please ensure that the bearing capacity of the supporting surface for the system must be over 1800 kg (it is calculated based on the 14 battery modules);
- In the case of wall mounting, the device shall be installed on the concrete wall. The bearing capacity of the wall, which enables it to bear the loads from the whole battery system, must be over {battery module weight (28 kg or 31 kg) × number of battery modules ($1 \leq n \leq 16$) × 4 (safety factor)};
- Please ensure that the thickness of any part of the wall should not be less than 150 mm;
- The device must not be installed on the wood wall.

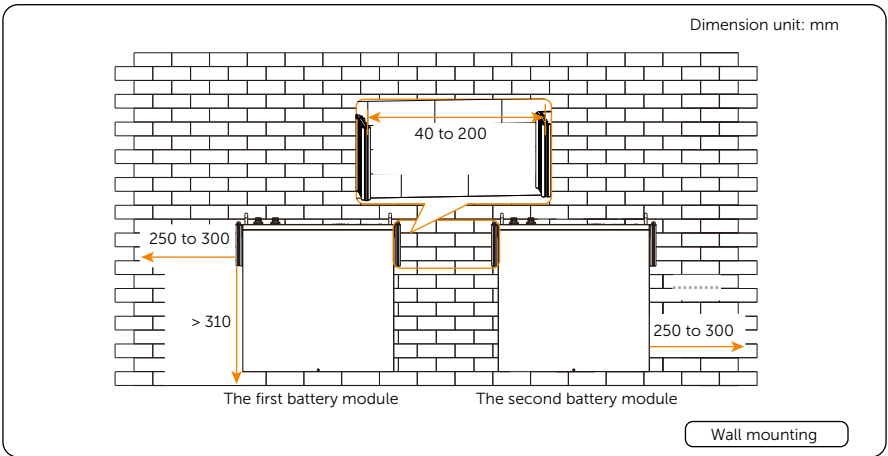
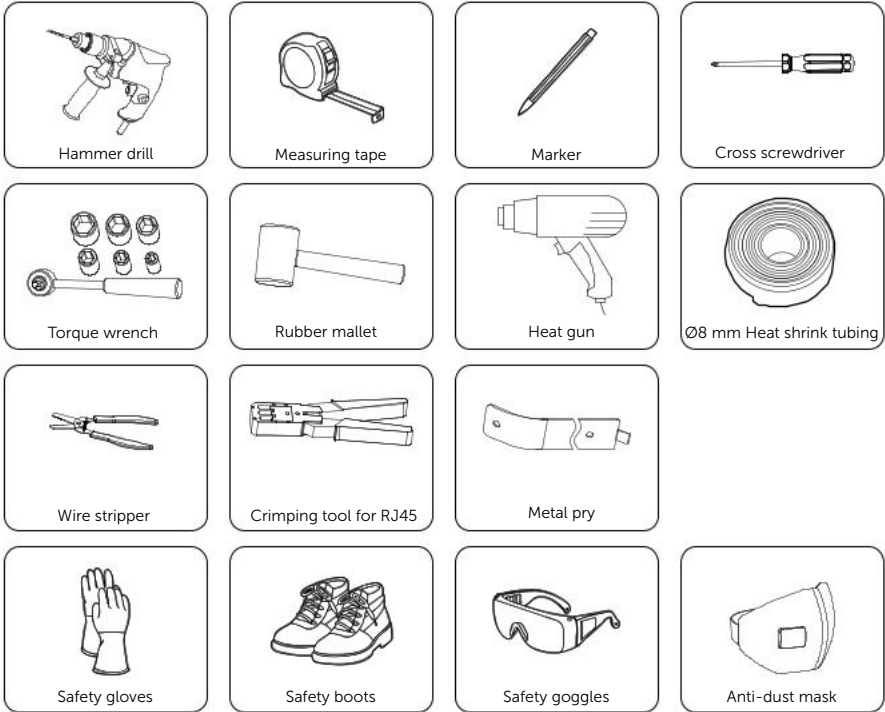

Figure 4-1 Clearance requirement

4.2 Tools Requirement

Installation tools include but are not limited to the following recommended ones. If necessary, use other auxiliary tools on site.



4.3 Additionally Required Materials

Table 4-1 Additionally required wires

No.	Required Material	Type	Diameter/ Conductor Cross-section
1	Protective pipe	Corrugated pipe	External diameter: over 60 mm
2	Grounding cable	/	10 mm ²

5 Unpacking and Inspection

The number of cartons will be different due to different modes of mounting. Therefore, please check whether the number of cartons received are correct before unpacking. For details, please refer to the following table.

Table 5-1 Number of cartons

Number of cartons	
Rack installation	Battery module $\times n$, Rack Installation $\times n^*$, Accessories Kit for Cables (for both rack and cabinet installation) $\times n^*$, Accessories Kit for Cables (connecting from the battery module to inverter) $\times 1^*$
Cabinet installation	Battery module $\times n$, Cabinet Installation $\times n^*$, Accessories Kit for Cables (for both rack and cabinet installation) $\times n^*$, Accessories Kit for Cables (connecting from the battery module to inverter) $\times 1^*$
Wall Mounting	Battery module $\times n$, Accessories Kit for Wall Mounting $\times n^*$, Accessories Kit for Cables (connecting from the battery module to inverter) $\times 1^*$

NOTICE!

- The letter "n" refers to the number of battery modules, which depends on how many battery modules the users purchased.
- The mark "*" indicates that the accessories kit is an additional product. The purchase of additional accessories kit will be subject to the users themselves.

5.1 Unpacking

- The rechargeable battery undergoes 100% testing and inspection before shipping from the manufacturing facility. However, transport damage may still occur. Before unpacking the rechargeable battery, please verify that the model and outer packing materials for damage, such as holes and cracks.
- Unpacking the battery module according to the following figures. If there are other cartons, such as the rack carton, cabinet carton, cables carton, or cartons about wall mounting, the unpacking procedure can also be referred to the following figures.

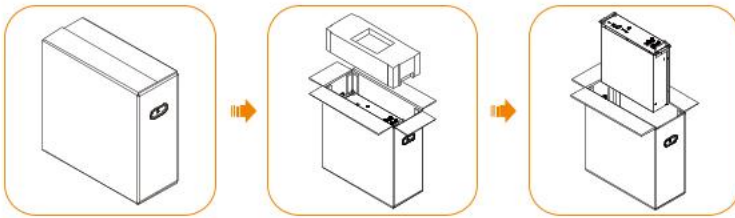

Figure 5-1 Unpacking the battery module

- Be careful when dealing with all package materials which may be reused for storage and relocation of the rechargeable battery in the future.
- Upon opening the package, check whether the appearance of the rechargeable battery is damaged or lack of accessories. If any damage is found or any parts are missing, contact your dealer immediately.

5.2 Scope of Delivery

One Battery Module (T-BAT LR25/T-BAT LR36 × 1)

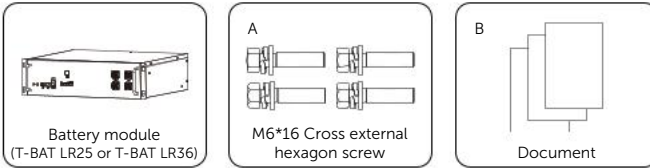

Table 5-1 Packing list of battery module (T-BAT LR25/ T-BAT LR36)

Item No.	Description	Quantity (Unit: pc)
/	Battery module (T-BAT LR25 or T-BAT LR36)	1
A	M6*16 Cross external hexagon screw	4
B	Document	/

NOTICE!

- The above items are only for one battery module. Our company will provide corresponding components according to battery modules.

Accessories Kit for Rack Installation (additional purchase is required)

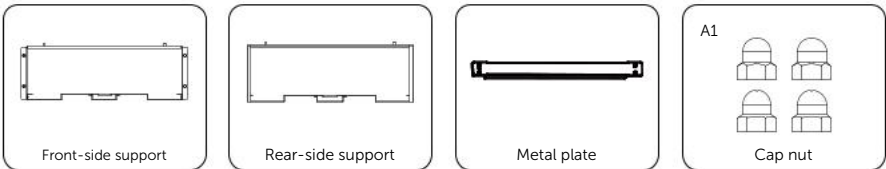

Table 5-2 Packing list of accessories kit for rack installation

Item No.	Description	Quantity (Unit: pc)
/	Front-side support	1
/	Rear-side support	1
/	Metal plate	1
A1	Cap nut	4

Accessories Kit for Cabinet Installation (additional purchase is required)

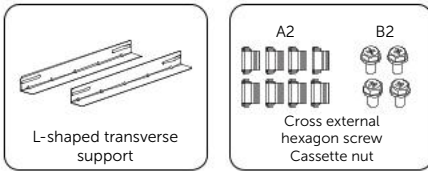

Table 5-3 Packing list of accessories kit for cabinet installation

Item No.	Description	Quantity (Unit: pc)
/	L-shaped transverse support	2
A2	M6*16 cross external hexagon screw	8
B2	Cassette nut	4

Accessories Kit for Cables (for both rack and cabinet installation) (additional purchase is required)

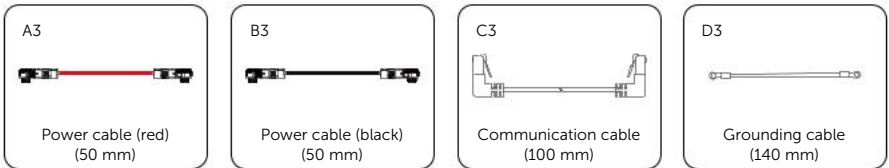

Table 5-4 Packing list of accessories kit for cables

Item No.	Description	Quantity (Unit: pc)
A3	Power cable (red) (50 mm)	1
B3	Power cable (black) (50 mm)	1
C3	Communication cable (100 mm)	1
D3	Grounding cable (140 mm)	1

Accessories Kit for Wall Mounting (additional purchase is required)

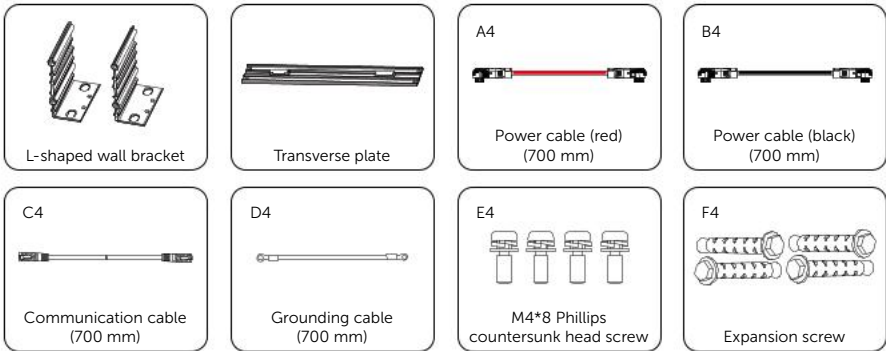

Table 5-5 Packing list of accessories kit for wall mounting

Item No.	Description	Quantity (Unit: pc)
/	L-shaped wall bracket	2
/	Transverse plate	1
A4	Power cable (red) (700 mm)	1
B4	Power cable (black) (700 mm)	1
C4	Communication cable (700 mm)	1
D4	Grounding cable (700 mm)	1
E4	M4*8 Phillips countersunk head screw	4
F4	Expansion screw	4

Accessories Kit for Cables (connecting from the battery module to inverter)

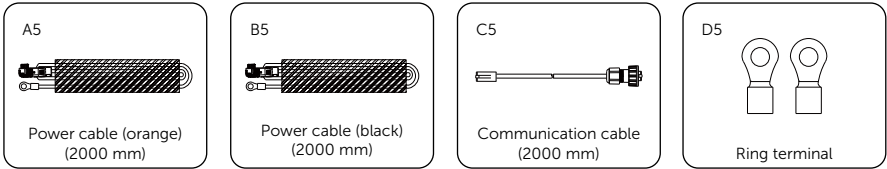

Table 5-6 Packing list of accessories kit for cables

Item No.	Description	Quantity (Unit: pc)
A5	Power cable (orange) (2000 mm)	1
B5	Power cable (black) (2000 mm)	1
C5	Communication cable (2000 mm)	1
D5	Ring terminal	2

NOTICE!

- The Accessories Kit for Cables (connecting from the battery modules to inverter) needs to be purchased separately.

6 Mechanical Installation

6.1 Installation Options

There are three installation options are available, with details as follows:

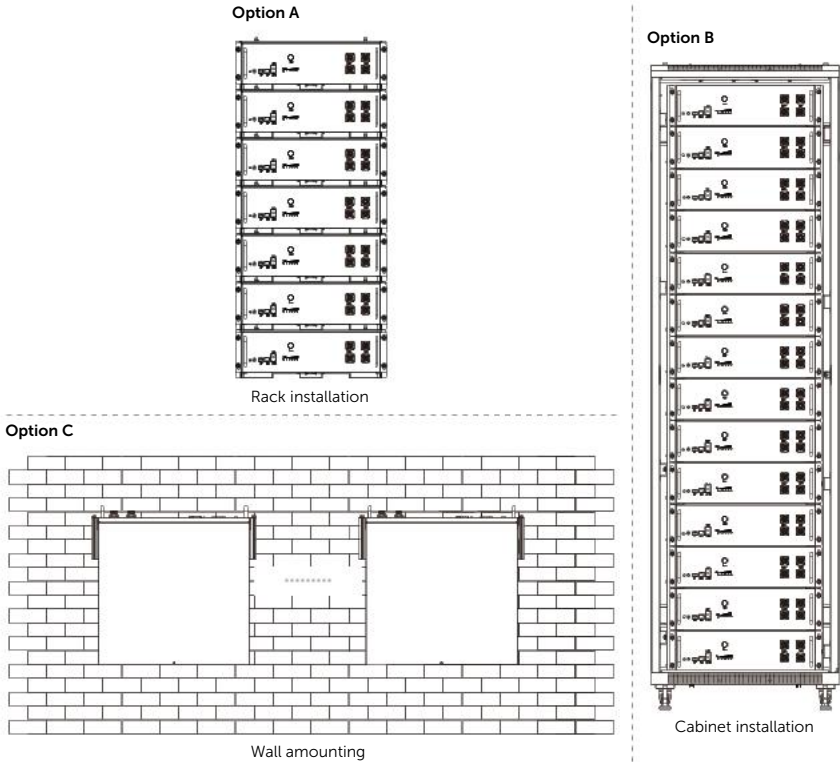

Figure 6-1 Installation options

NOTICE!

- The option of rack installation may withstand up to seven battery modules.
- Regarding the cabinet shown in the above figure, it is a standard cabinet with a width and depth of 600 mm, and will not be provided by our company. Users may purchase it based on their demands.
- Regarding the wall mounting, up to sixteen battery modules can be installed in a straight line.

6.2 Installation Procedure

WARNING!

- Only the qualified personnel can perform the mechanical installation following the local standards and requirements.
- Check the existing power cables or other piping in the wall to prevent electric shock or other damage.
- Do not expose the battery modules to humid environment.

CAUTION!

- Always be aware of the weight of the battery. Personal injuries may result if the battery is lifted improperly or dropped while being transported or mounted.
- Use insulated tools and wear individual protective tools when installing the battery.

NOTICE!

- The number of battery modules that can be installed varies depending on different installation options.
 - a. If the rack installation is selected, up to 7 battery modules can be installed.
 - b. If the cabinet installation is selected, two sizes of cabinet are available, such as 22U and 42U. In the case of 22U, up to 7 battery modules can be installed; in the case of 42U, up to 14 battery modules can be installed.
 - c. If the wall mounting is selected, up to 16 battery modules can be installed.

	Rack installation	Cabinet installation	Wall mounting
Max. number of battery modules	7	14	16

- In the case of rack installation, please ensure that the bearing capacity of the ground, which enables it to bear the loads from the whole battery system, must be over 800 kg (it is calculated based on the 7 battery modules).
- In the case of cabinet installation, please ensure that the bearing capacity of the ground, which enables it to bear the loads from the whole battery system, must be over 1800 kg (it is calculated based on the 14 battery modules).
- In the case of wall mounting, the device shall be installed on the concrete wall. The bearing capacity of the wall, which enables it to bear the loads from the whole battery system, must be over (battery module weight x number of battery modules x 4).
- It is recommended that the battery rack and battery cabinet be installed against the wall for stability.
- In the case of cabinet installation, at least a distance of 100 mm from the cabinet to the ceiling shall be reserved to allow access to conduct wiring.
- In the case of wall mounting, regarding the neighbouring two assembled wall brackets, the distance between the right outside bracket of one and the left outside bracket of the other shall be between 40 and 200 mm, and the distance from the device to either the left or right walls shall be between 250 and 300 mm.
- The following installation procedures apply to both T-BAT LR25 and T-BAT LR36.

6.2.1 Installation Procedure with Rack

NOTICE!

- Regarding the rack, users may purchase from our company.
- The following steps take seven battery modules as an example.

Step 1: Assemble the rack.

Determine the front-side and rear-side supports, and then place them on the ground.

Insert the metal plate into the location holes on the grooves.

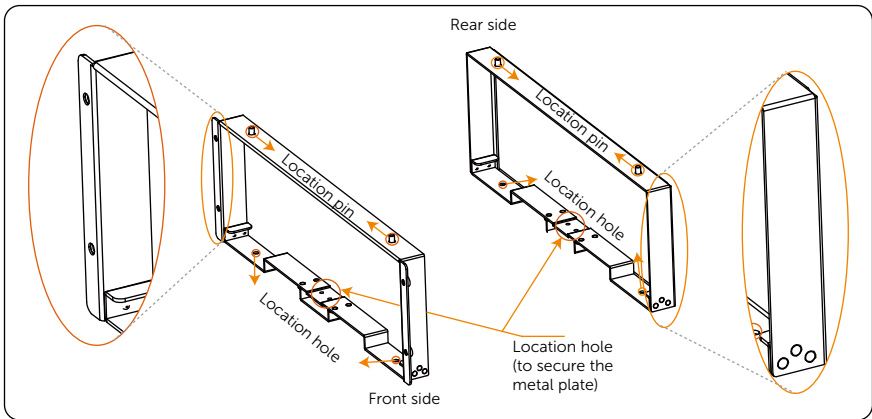

Figure 6-2 Placing the supports

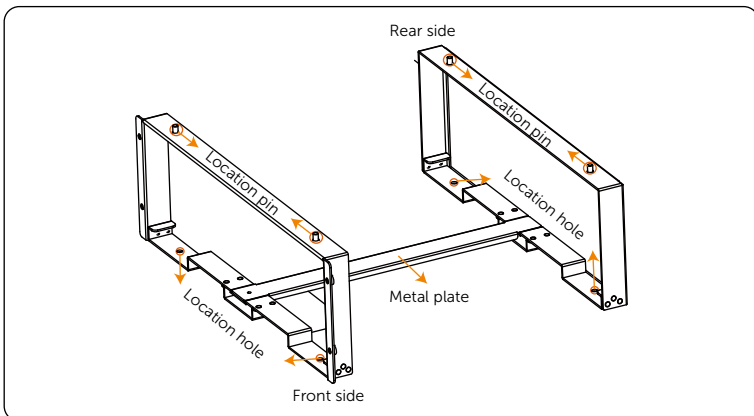

Figure 6-3 Inserting metal plate

Step 2: Gently place the battery module into the assembled rack, and correctly install and tighten M6*16 cross external hexagon screw (Part A) (x 4 pcs) (Tightening torque: 4-5 N·m).

NOTICE!

- It is recommended that the battery rack be installed against the wall for stability.

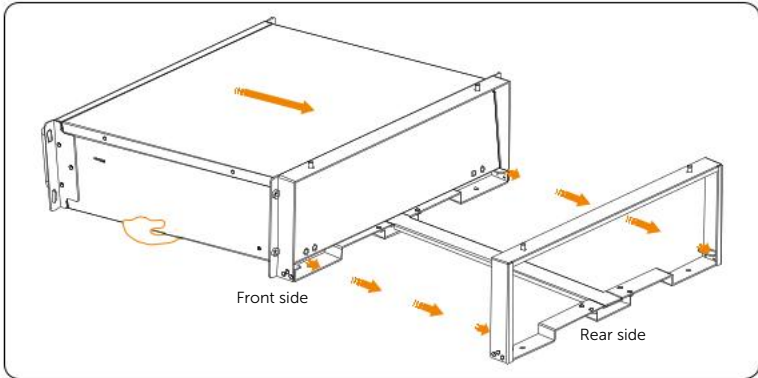

Figure 6-4 Placing the battery module into the rack

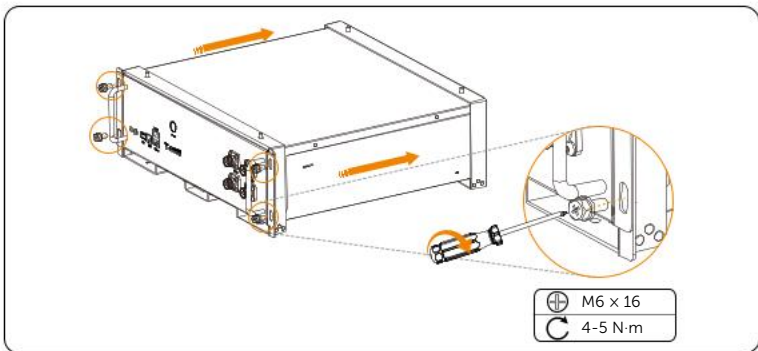

Figure 6-5 Tightening M6 screws

Step 3: Placing another front-side and rear-side supports, and correctly install and tighten cap nut (Part A1) (x 4 pcs) to secure supports (Tightening torque: 4-6 N·m).

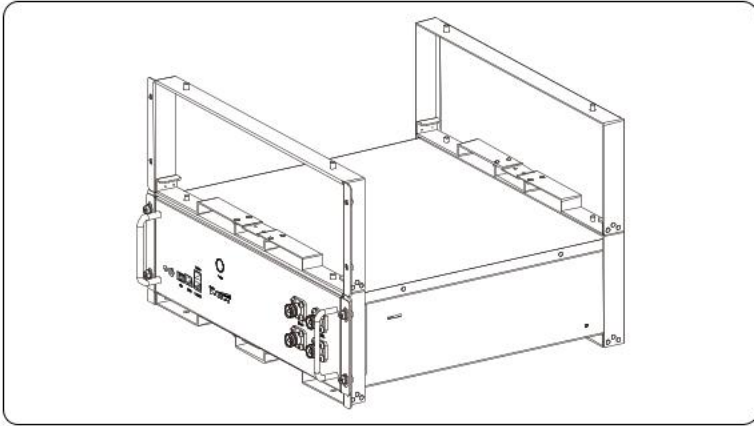

Figure 6-6 Placing front-side and rear-side supports

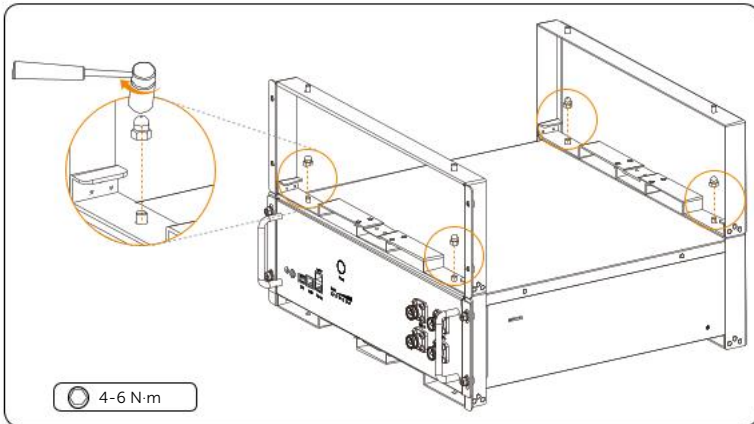

Figure 6-7 Tightening cap nuts

Step 4: Insert the metal plate into the location holes on the grooves.

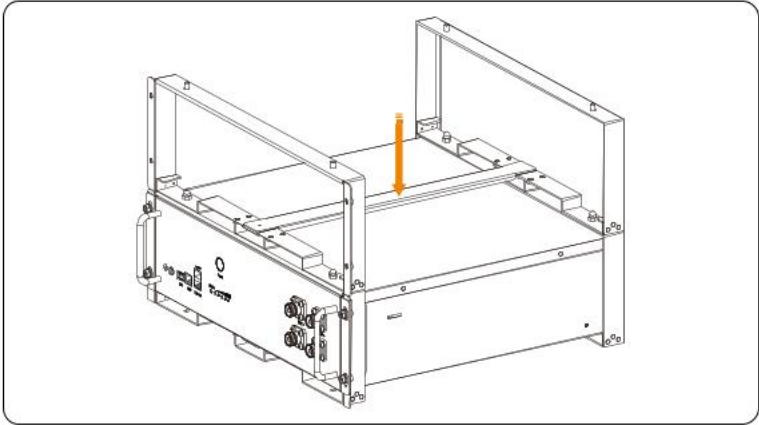

Figure 6-8 Placing the metal plate

Step 5: Gently place the second battery module into the assembled rack, and correctly install and tighten M6*16 cross external hexagon screw (x 4 pcs) (Tightening torque: 4-5 N·m).

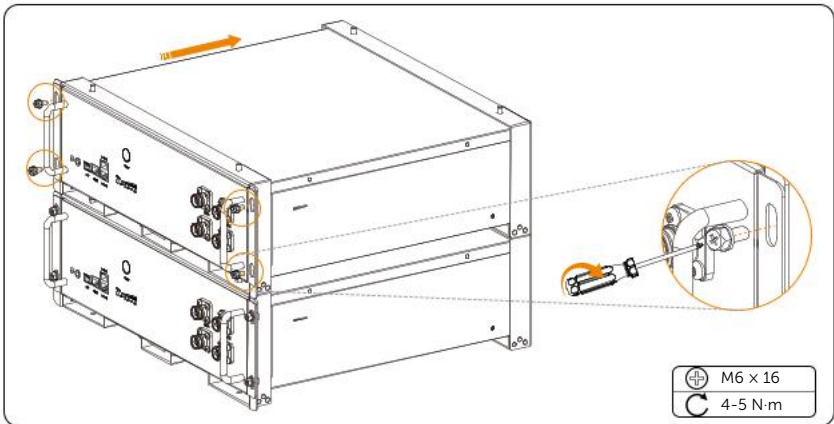

Figure 6-9 Placing the battery module and tightening M6 screws

Step 6: Follow the above steps 3 to 5 to place the remaining battery modules. And up to seven battery modules can be installed.

NOTICE!

- Don't forget insert and tight cap nuts after placing the supports and the last battery module.

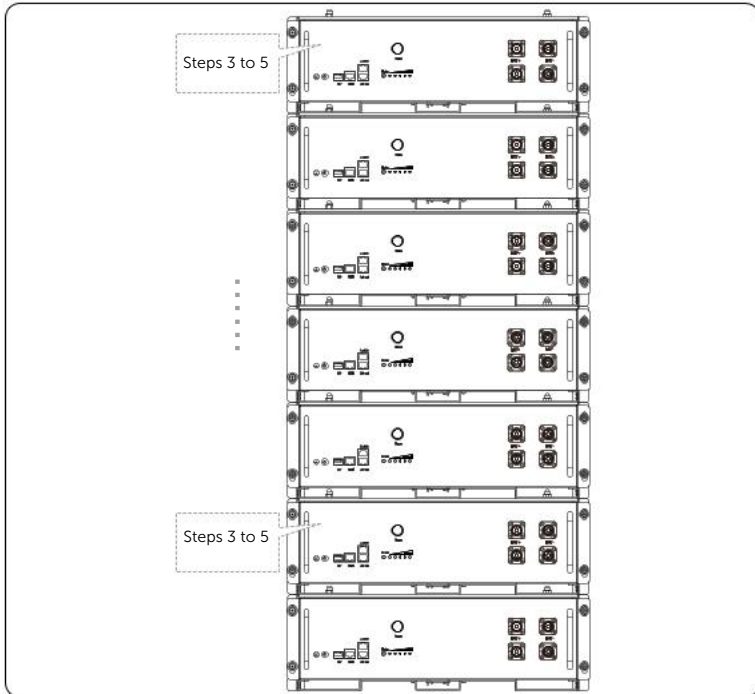

Figure 6-10 Placing the remaining battery modules

CAUTION

In case the battery module(s) need(s) to be maintained, please do as follows:

- If the entire device needs to be replaced, strictly follow the reverse order of the installation procedure to remove the rack and battery modules from top to down.
- If one of the battery modules needs to be maintained, just remove such a battery module, and then reinstall it back in place after finishing maintenance.
- If more than one battery module needs to be maintained, please do as follows:
 - a. Firstly, remove one battery module to do maintenance;
 - b. Secondly, reinstall such a battery module back in place after finishing maintenance;
 - c. Thirdly, repeat steps a to b to maintain another battery module.

6.2.2 Installation Procedure with Cabinet

NOTICE!

- Regarding the installation of the outside cabinet, please follow the *Guide* delivered with the cabinet.
- When installing outside cabinet, the cassette nuts shall be inserted before installing fixed rails. There are totalling three fixed rails on each left and right side. 4 cassette nuts shall be inserted into each fixed rail.

Step 1: Before conducting the installation, please determine which side is the front side.

The side with the threading outlet on the top cover is the front side.

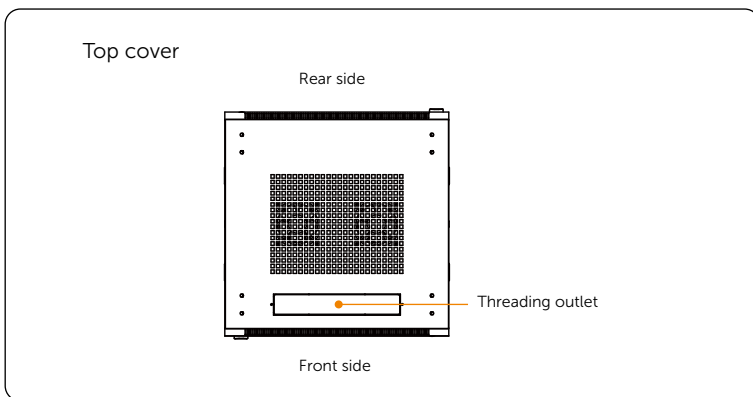

Figure 6-11 Determining the front side

Step 2: Correctly insert cassette nuts into the fix rails via proper use of a metal pry.

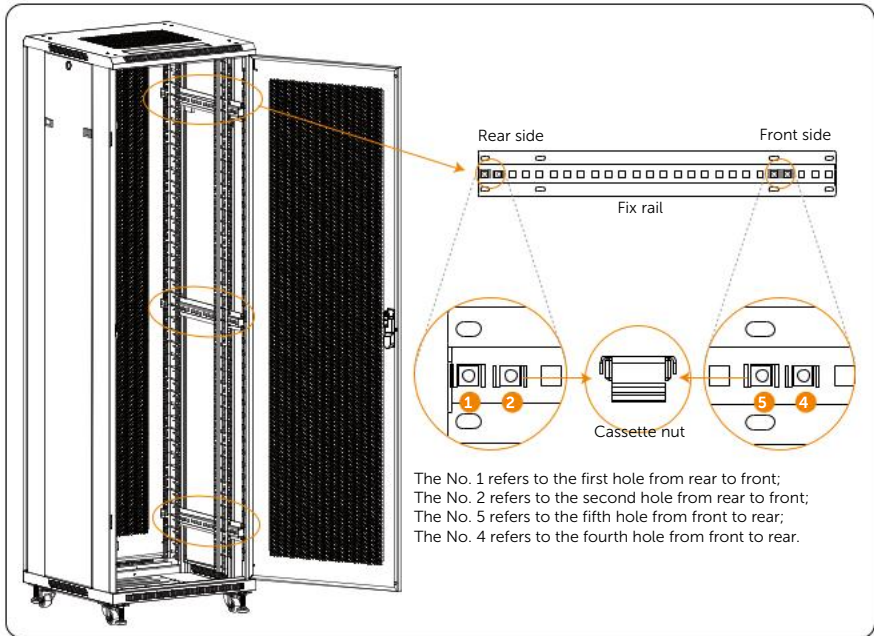

Figure 6-12 Inserting cassette nuts

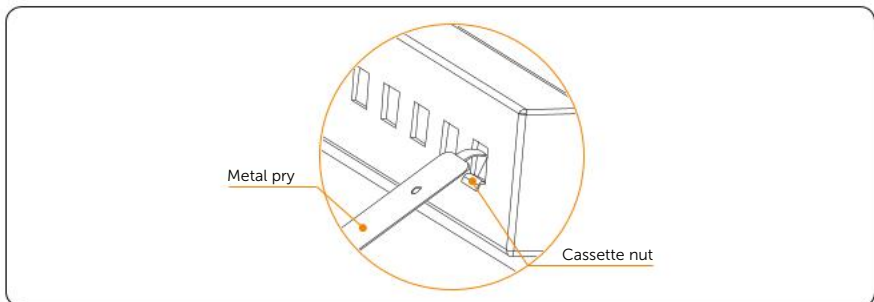

Figure 6-13 How to use a metal pry

NOTICE!

- There are two alternative sizes (22U and 42U) of cabinets available for users.
- The following steps take 42U (1U=4.445 cm) with 14 battery modules as an example.
- Regarding the installation of the inside cabinet and battery modules, please follow the steps as below.
- A metal pry can be used while inserting or removing cassette nuts.

Step 3: Insert the cassette nuts into the mounting rails every 3U, with totalling 14 cassette nuts per mounting rail.

The distance between two mounting rails on one side shall not exceed 330 mm.

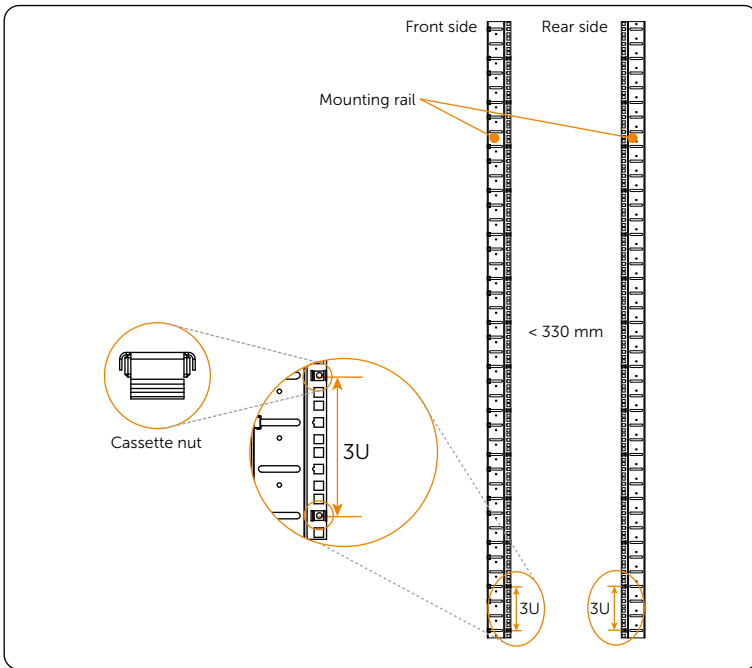

Figure 6-14 Inserting cassette nuts

NOTICE!

- Totalling 4 mounting rails shall be installed, with 2 rails on each side. The four rails are in Package C of the NCB Network Cabinet.
- The distance between two mounting rails shall not exceed 330 mm.
- 1U = 4.445 cm.

Step 4: Insert the cassette nut (Part A2) into the holes on the mounting rails facing the cabinet door, with totalling 28 cassette nuts per mounting rail.

1. Insert the first cassette nut into the hole at the bottom of the mounting rail;
2. Insert the second cassette nut 2U from the first one;
3. Insert the third cassette nut 1U from the second one;
4. Insert the fourth cassette nut 2U from the third one;
5. Insert the fifth cassette nut 1U from the fourth one;
6. Then repeat steps "2" and "3" to insert the remaining cassette nuts.

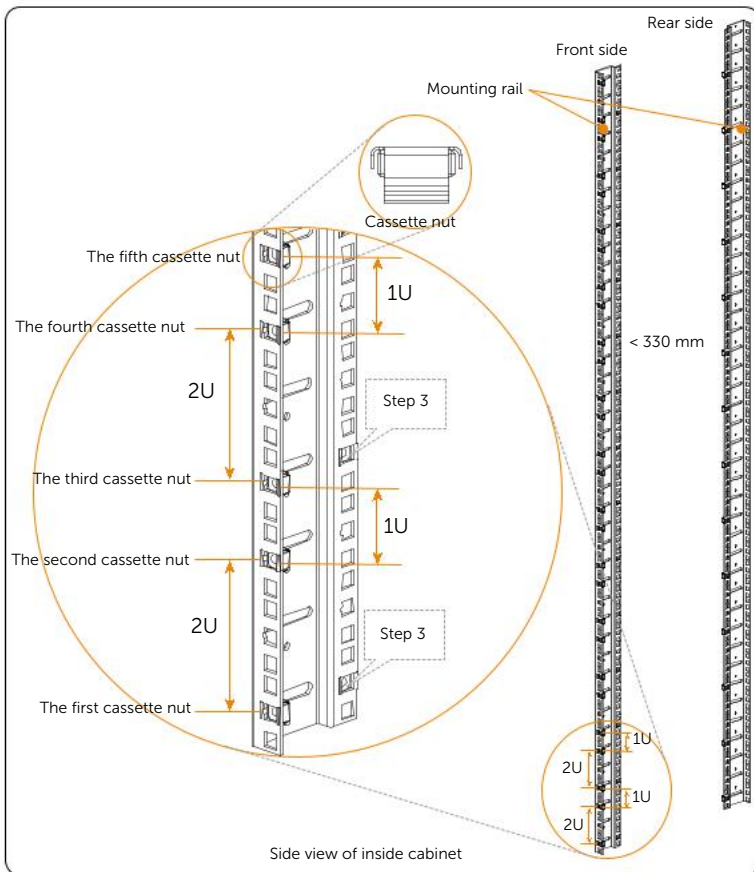

Figure 6-15 Inserting cassette nuts

NOTICE!

- Only two mounting rails facing the cabinet door shall be inserted the cassette nuts, with a total of 28 nuts per mounting rail.
- 1U = 4.445 cm

Step 5: Attach the l-shaped transverse support, and make the holes on the l-shaped transverse plate align with the cassette nuts inserted at step 2.

Correctly insert and tighten M6 cross external hexagon screws (x 2) (Tighten torque: 4-5 N·m).

L-shaped transverse supports need to be installed on both sides.

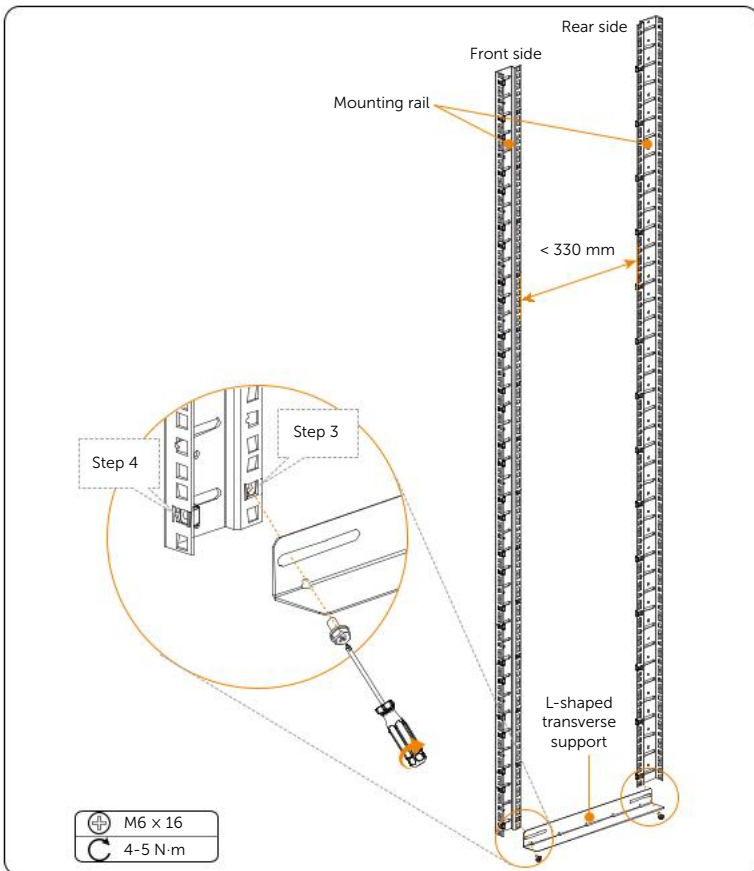

Figure 6-16 Attaching l-shaped transverse support and tightening M6 screws

NOTICE!

- Please make sure that the two mounting rails on the same side are at the same level.
- The two location holes on the l-shaped transverse support are long, please attach M6 screws at the end of the holes near the mounting rail.

Step 6: After all l-shaped transverse supports are secured, attach the assembled mounting rails into the cabinet, and correctly install and tighten M6*16 cross external hexagon screw (Part B2) (× 4 pcs) to fasten mounting rail and fix rail.

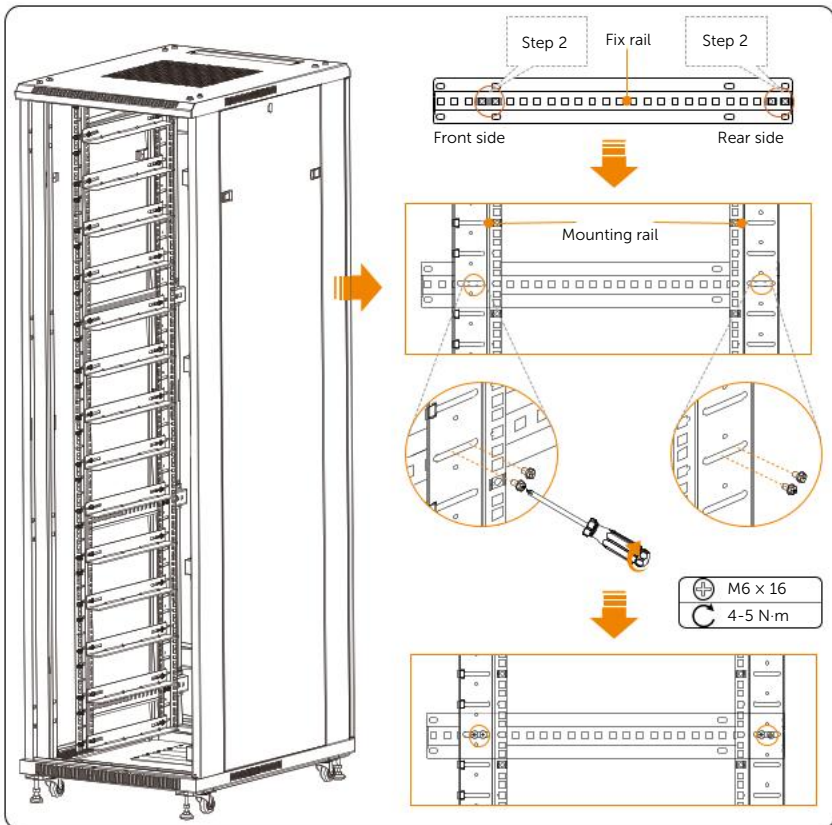

Figure 6-17 Attaching assembled mounting rails and tightening M6 screws

NOTICE!

- The cassette nuts must be inserted before installing the assembled mounting rails.
- Please make sure that the four mounting rails are at the same level.
- The screws to fasten the mounting rail and fix rail are delivered with the cabinet. Four M6 screws shall be attached and tightened per fix rail. Regarding the screw position, please follow step 1 strictly.
- Please prevail in kind.

Step 7: Gently place the battery into the cabinet, and correctly insert and tighten M6*16 cross external hexagon screw (Part A) (x 4 pcs) (Tightening torque: 4-5 N-m).



Figure 6-18 Placing battery modules and tightening M6 screws

Step 8: Repeat step 6 to place the remaining battery modules. See figure below.

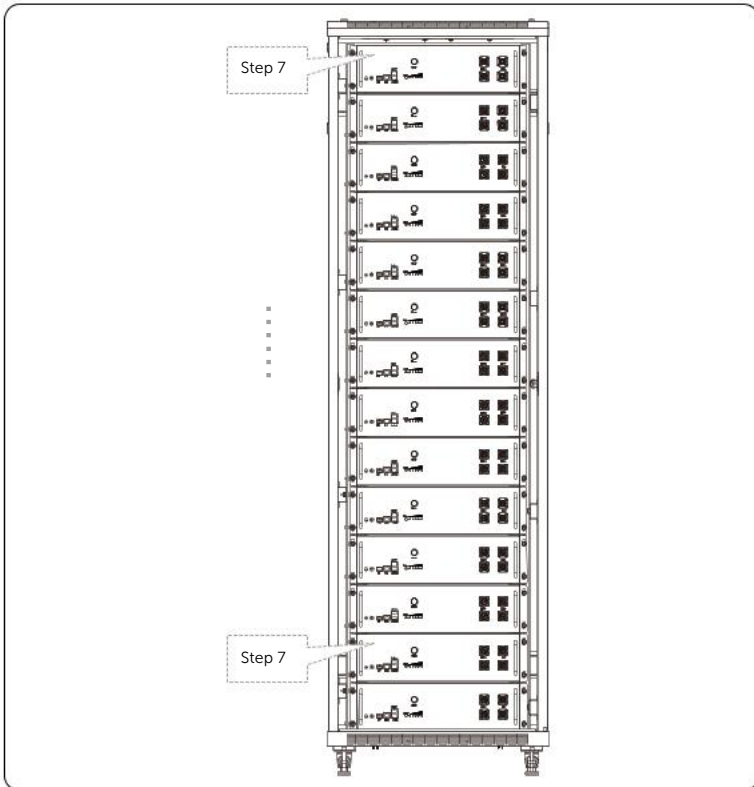

Figure 6-19 Placing battery modules

NOTICE!

- Please prevail in kind.

6.2.3 Wall Mounting

Step 1: Attach the l-shaped wall brackets and transverse plate together, and correctly insert and tighten M4*8 phillips countersunk head screw (Part E4) (x 4 pcs) (Tightening torque: 1.2-2.2 N·m).

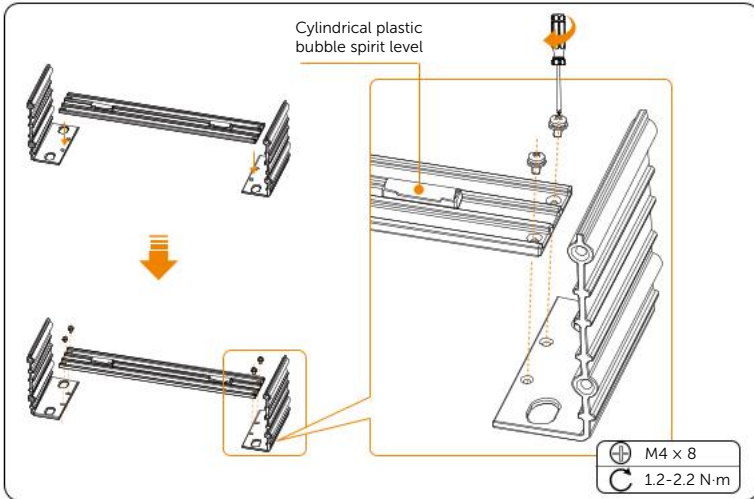

Figure 6-20 Securing l-shaped wall brackets and transverse plate

Step 2: Attach the assembled wall bracket to the wall, and make sure that it is level via the cylindrical plastic bubble spirit level on the transverse plate.

Draw a circle along the inner ring, with a total of 4 circles.

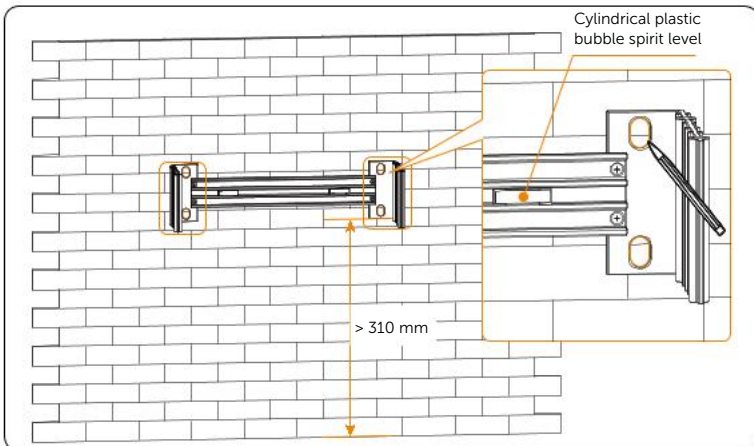

Figure 6-21 Drawing circles

NOTICE!

- At least 310 mm of the distance from the bottom of the l-shaped wall bracket to the ground must be reserved.
- When installing the first and last battery modules, the distance from the battery modules to either the left or right wall shall be between 250 and 300 mm.

Step 3: Remove the assembled wall bracket, and then drill four holes at a depth of more than 90 mm in the concrete wall by using a Drill ($\varnothing 12$ mm).

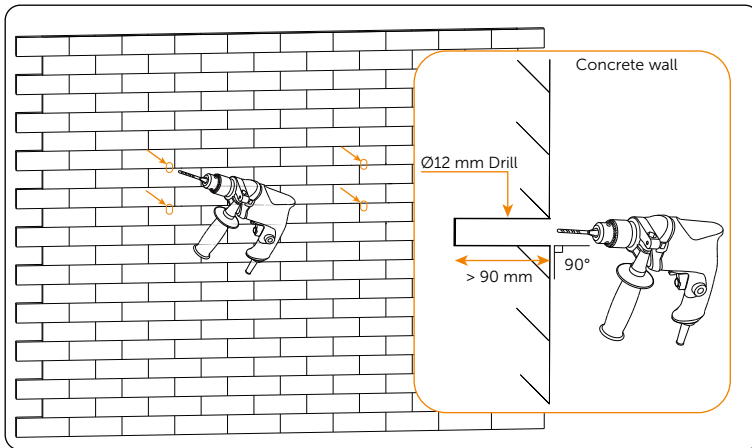

Figure 6-22 Drilling holes

NOTICE!

- Currently, the battery module can only be installed on the concrete wall.
- An electric drill dust collector is recommended.

Step 4: Correctly insert and tighten expansion screw (Part F4) (x 4 pcs) to secure the assembled wall bracket (Tightening torque: 20-25 N·m).

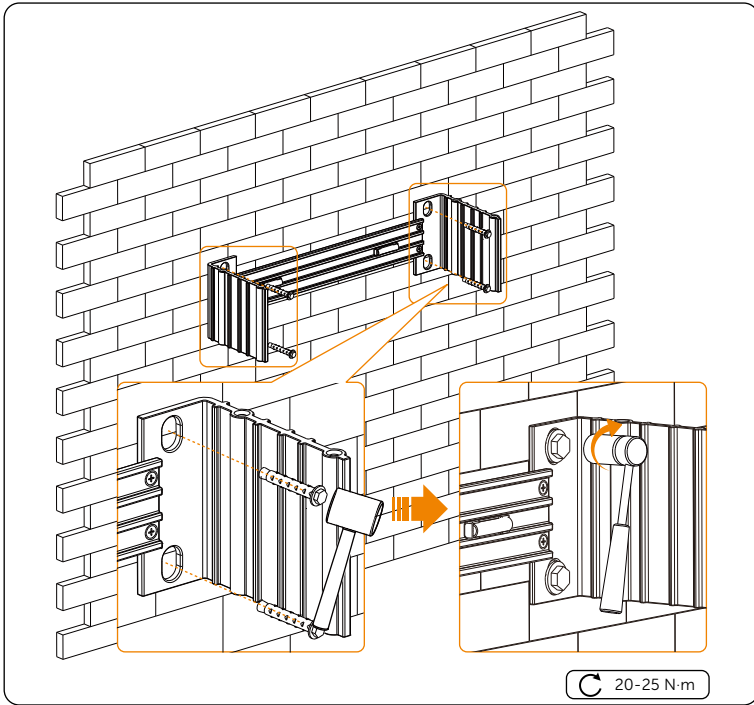

Figure 6-23 Tightening expansion screw

NOTICE!

- Please make sure that it is level via the cylindrical plastic bubble spirit level on the transverse plate.

Step 5: Gently place the battery module on the assembled wall bracket and align the holes.

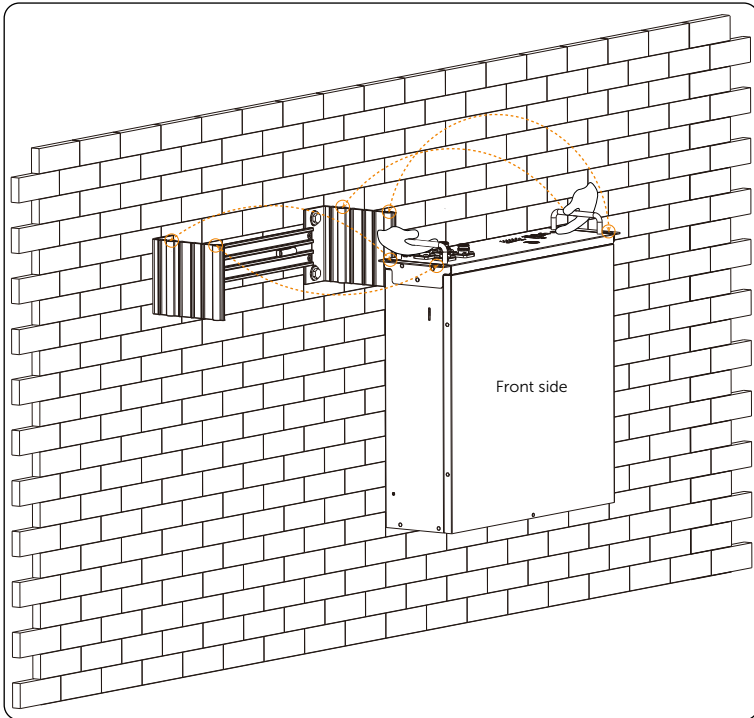

Figure 6-24 Placing battery module

NOTICE!

- For aesthetic purposes, it is recommended that the rear side of the battery module be against the wall.

Step 6: Correctly insert and tighten M6*16 Cross external hexagon screw (Part A) (x4 pcs) to secure the battery module (Tightening torque: 4-5 N·m).

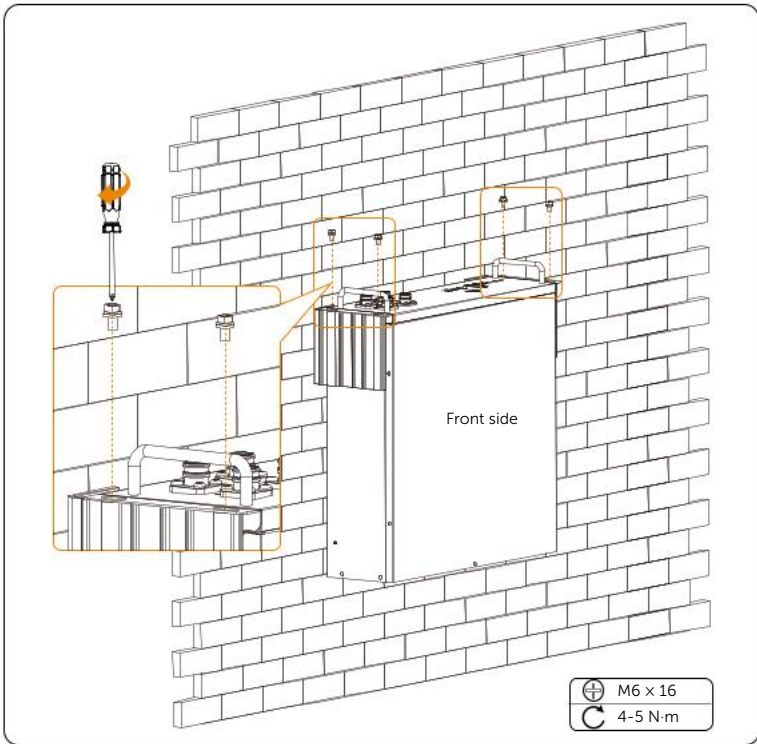

Figure 6-25 Tightening M6 screws

Step 7: Repeat steps 1 to 6 to install other battery modules (if any).

NOTICE!

- Regarding the neighbouring two assembled wall brackets, the distance between the right outside bracket of one and the left outside bracket of the other shall be between 40 and 200 mm.
- Up to sixteen battery modules can be installed in a straight line.

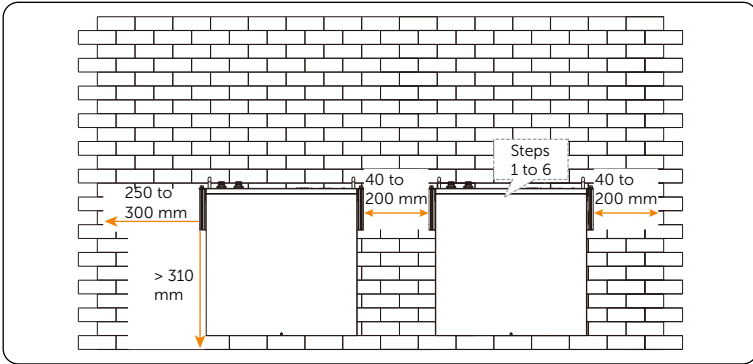

Figure 6-26 Installing the second battery module

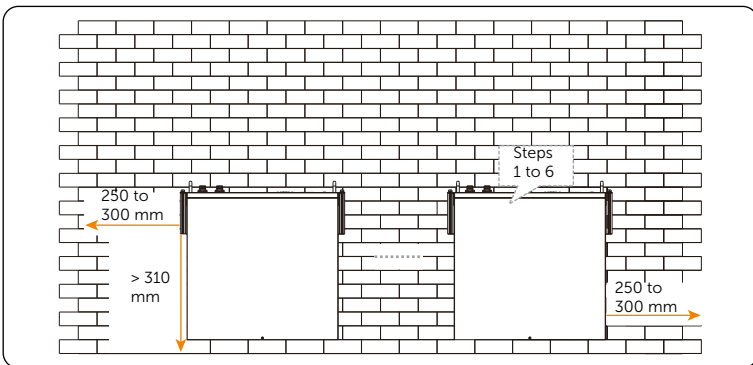

Figure 6-27 Installing other battery modules

7 Wiring

Regarding the PE and communication cable, of which one end connects to the inverter, it shall be made before conducting wiring.

7.1 PE Connection

The steps for making PE connection are shown as follows:

Step 1: Strip the cable jacket about 8 to 10 mm from the end.

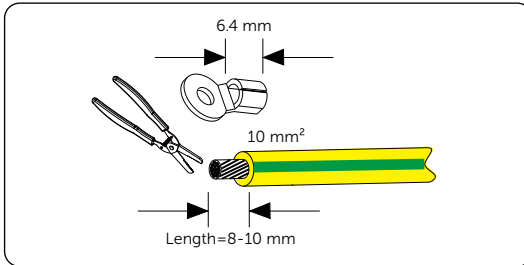

Figure 7-1 Stripping cable jacket

Step 2: Cut the heat-shrink tubing to about 28 to 30 mm long, carefully slide it onto the end of the cable, and then carefully slip the wires all the way into the ring terminal (Part D5).

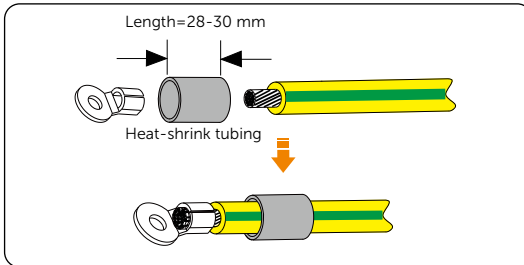

Figure 7-2 Cutting heat-shrink tubing

Step 3: Crimp the terminal, and heat the heat-shrink tubing after it wraps the end of terminal.

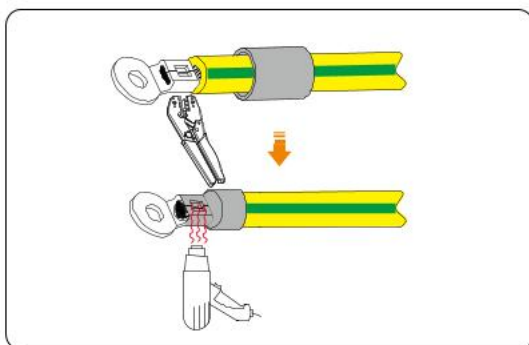

Figure 7-3 Crimping and heating

Step 4: Unscrew the M5 screw, and then connect the assembled grounding cable to the grounding port of the battery module, and then tighten M5 screw (Tightening torque: 2.2-2.5 N·m).

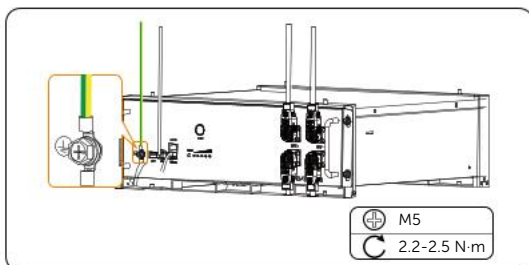

Figure 7-4 Tightening M5 screws

NOTICE!

- Regarding the cables that are prepared by the users themselves, a wire size of 10 mm² for cables is recommended.
- If the grounding cable is prepared by the user, please purchase it according to the above-mentioned requirements.

7.2 Communication Connection (connecting to inverter)

To ensure normal operation of the battery module and inverter, the communication cable delivered with the Accessories Kit for Cables (connecting from the battery module to inverter) is required to connect RJ45 connector.

The specific definition of the communication cable is shown as follows:

Table 7-1 Specific definition

PIN	1	2	3	4	5	6	7	8
BMS	RS485B	RS485A	GND	CAN-H	CAN-L	12V-OUT	MASTER-IN	/

The wire sequence of one terminal connecting to the inverter is the same as the wire sequence of the other terminal, connecting to the battery module.

The wire sequence is shown as follows:

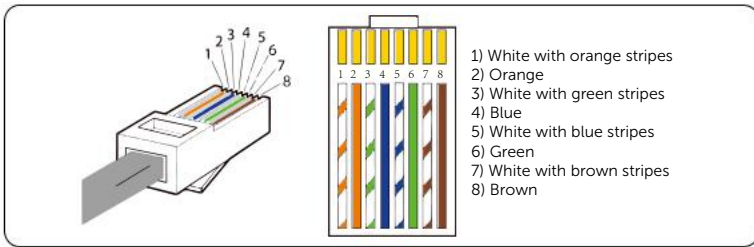

Figure 7-5 Wire sequence

The steps for making RJ45 connector to communication cable (Part C5) are shown as follows:

- Step 1:** Strip the cable jacket about 15 mm down from the end.
- Step 2:** Carefully insert the wires all the way into the RJ45 connector, making sure that each wire passes through the appropriate guides inside the connector.
- Step 3:** Push the RJ45 inside the crimping tool and squeeze the crimper all the way down.

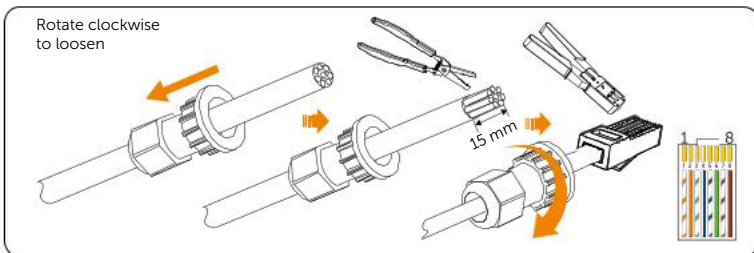









Figure 7-6 Making RJ45 connector to communication cable



NOTICE!

- The communication cable shall have a shield layer.

7.3 Details of Cables

Table 7-2 Details of cables

Cable	Length	Purpose	Qty
For both rack and cabinet installation			
 Power cable (black)	50 mm	There are two terminals at both ends: one connects to the "B-" port of a battery module, and the other connects to the "B-" port of the neighbouring battery module.	1 pc
 Power cable (red)	50 mm	There are two terminals at both ends: one connects to the "B+" port of a battery module, and the other connects to the "B+" port of the neighbouring battery module.	1 pc
 Communication cable	100 mm	There are two terminals at both ends: one connects to the "Link in" port of a battery module, and the other connects to the "Link out" port of the neighbouring battery module.	1 pc
 Grounding cable	140 mm	There are two terminals at both ends: one connects to the grounding port of a battery module, and the other connects to the grounding port of the neighbouring battery module.	1 pc
For wall mounting			
 Power cable (black)	700 mm	There are two terminals at both ends: one connects to the "B-" port of a battery module, and the other connects to the "B-" port of the neighbouring battery module.	1 pc
 Power cable (red)	700 mm	There are two terminals at both ends: one connects to the "B+" port of a battery module, and the other connects to the "B+" port of the neighbouring battery module.	1 pc
 Communication cable	700 mm	There are two terminals at both ends: one connects to the "Link in" port of a battery module, and the other connects to the "Link out" port of the neighbouring battery module.	1 pc

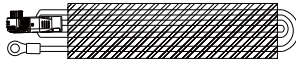
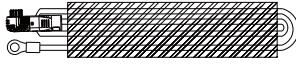
	<p>There are two terminals at both ends: one connects to the grounding port of a battery module, and the other connects to the grounding port of the neighbouring battery module.</p>	1 pc
<p>Grounding cable 700 mm</p>		
For connecting from the battery module to the inverter		
	<p>There are two terminals at both ends: one connects to the "BMS" port of the battery module, and the other connects to the "BMS" port of the inverter.</p>	1 pc
<p>Communication cable 2000 mm</p>		
	<p>Two ring terminals can be seen in the Accessories Kit for Cables (connecting from the battery module to the inverter). The grounding cable should be made by the user himself/herself.</p>	
<p>(for connecting to inverter)</p>		
	<p>There are two terminals at both ends: one connects to the "B-" port of the battery module, and the other connects to the "BAT-" port of the inverter.</p>	1 pc
<p>Power cable (black) 2000 mm</p>		
	<p>There are two terminals at both ends: one connects to the "B+" port of the battery module, and the other connects to the "BAT+" port of the inverter.</p>	1 pc
<p>Power cable (orange) 2000 mm</p>		

NOTICE!

- All the above-mentioned cables (both connecting from the battery module to the battery module, and from the battery module to the inverter) need to be purchased separately.

7.4 Wiring Procedure

WARNING!

- Only the qualified personnel can perform the wiring.
- Follow this manual to wire connection. The device damage caused by incorrect cabling is not in the scope of warranty.

CAUTION!

- Use insulated tools and wear individual protective tools when connecting cables.
- Do not bend the power cable, particularly at the point where the cable joins the connector, at 90° while conducting wiring.

NOTICE!

- The wiring procedure applies to two types of T-BAT LR25 and T-BAT LR36.



7.4.1 Wiring Procedure about Rack Installation

Battery Module to Neighbouring Battery Module

NOTICE!

- The cables in the following table need to be purchased separately.

Table 7-3 Battery module to neighbouring battery module

Cable	Length	Purpose	Qty
		"Link in" port to "Link out" port	1 pc
Communication cable (Part C3)	100 mm		
		"B-" port to "B-" port	1 pc
Power cable (black) (Part B3)	50 mm		
		"B+" port to "B+" port	1 pc
Power cable (red) (Part A3)	50 mm		



Grounding cable (Part D3) 140 mm

Grounding port to grounding port 1 pc

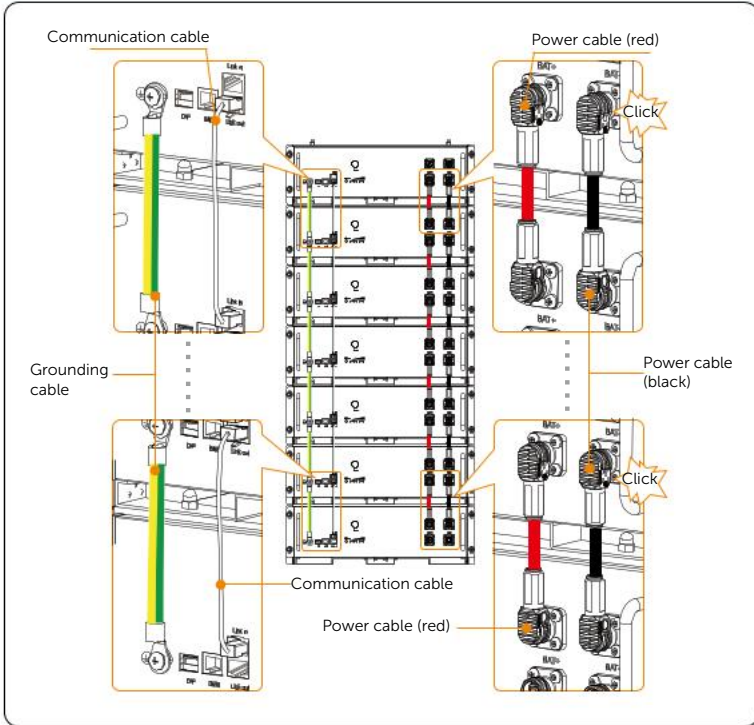
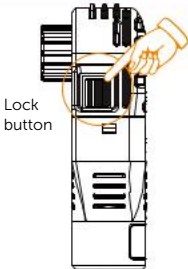

Figure 7-7 Cable connection between battery modules

NOTICE!







- Two terminals (see left figure) are equipped at both ends of power cables. Therefore, please press and hold the "Lock button" while unplugging the power cable. Otherwise, it cannot be pulled out.
- Don't violently remove the power cables when they are locked.

Battery Module to Inverter

NOTICE!

- Regarding the PE connection, please refer to "[PE Connection](#)".
- Regarding the communication connection, please refer to "[Communication Connection \(connecting to inverter\)](#)".
- The cables in the following table need to be purchased separately.

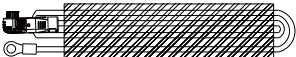
Table 7-4 Battery module to inverter

Cable	Length	Purpose	Qty
	2000 mm	"BMS" port to "BMS" port	1 pc
Communication cable (Part C5)	2000 mm		
	2000 mm	"B-" port to "BAT-" port	1 pc
Power cable (black) (Part B5)	2000 mm		
	2000 mm	"B+" port to "BAT+" port	1 pc
Power cable (orange) (Part A5)	2000 mm		
		Grounding port to grounding port	2 pcs
Ring terminal (Part D5)			

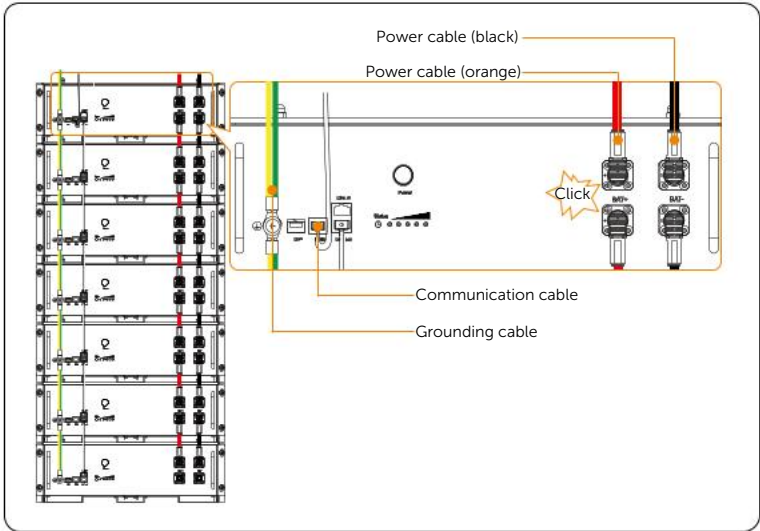
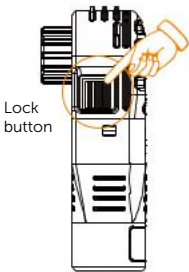

Figure 7-8 Connecting cables between the battery module and the inverter

NOTICE!



- A terminal (see left figure) is equipped at one end of power cables. Therefore, please press and hold the "Lock button" while unplugging the power cable. Otherwise, it cannot be pulled out.
- Don't violently remove the power cables when they are locked.

NOTICE!

- The connector on the power cable, connected to the inverter, is delivered with the inverter. Regarding the detailed assembly procedure, please refer to the inverter's *User Manual*.
- Users should hear the sound of "Click" while unplugging in the power cable. It indicates that the cable connector is properly plugged into the port.
- The "Link" port on the battery module is for parallel connections only. Don't use it for any other purposes.





7.4.2 Wiring Procedure about Cabinet Installation

Battery Module to Neighbouring Battery Module

NOTICE!

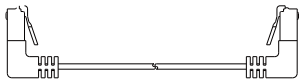
- The cables in the following table need to be purchased separately.

Table 7-5 Battery module to neighbouring battery module

Cable	Length	Purpose	Qty
		"Link in" port to "Link out" port	1 pc
Communication cable (Part C3)	100 mm		
		"B-" port to "B-" port	1 pc
Power cable (black) (Part B3)	50 mm		
		"B+" port to "B+" port	1 pc
Power cable (red) (Part A3)	50 mm		
		Grounding port to grounding port	1 pc
Grounding cable (Part D3)	140 mm		

⚠ CAUTION!

- When the cable insulation layer is chewed through, this can cause short circuits and potentially start an electrical fire. Therefore, where there is a risk of pests, rodents, or termites, protective barriers or additives are suggested to be added to the cables to prevent damage.

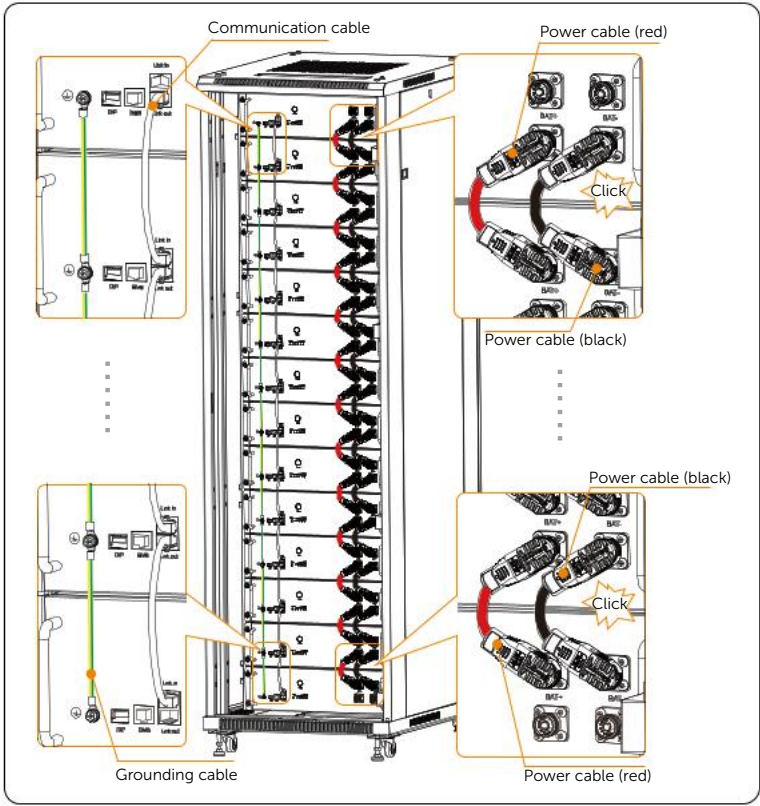
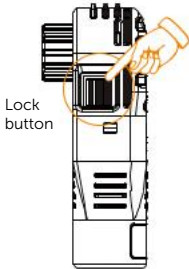

Figure 7-9 Cable connection between battery modules

NOTICE!





- Two terminals (see left figure) are equipped at both ends of power cables. Therefore, please press and hold the "Lock button" while unplugging the power cable. Otherwise, it cannot be pulled out.
- Don't violently remove the power cables when they are locked.

Battery Module to Inverter

NOTICE!

- Regarding the PE connection, please refer to "[PE Connection](#)".
- Regarding the communication connection, please refer to "[Communication Connection \(connecting to inverter\)](#)".
- The cables in the following table need to be purchased separately.

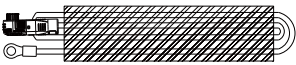
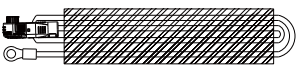
Table 7-6 Battery module to inverter

Cable	Length	Purpose	Qty
	2000 mm	"BMS" port to "BMS" port	1 pc
Communication cable (Part C5)	2000 mm		
	2000 mm	"B-" port to "BAT-" port	1 pc
Power cable (black) (Part B5)	2000 mm		
	2000 mm	"B+" port to "BAT+" port	1 pc
Power cable (orange) (Part A5)	2000 mm		
		Grounding port to grounding port	2 pcs
Ring terminal (Part D5)			

There are two ways to connect to the inverter:

- Wiring from the bottom battery module to the inverter, please refer to Figure 7-10.
- Wiring from the uppermost battery module to the inverter, please refer to the Figure 7-11.

 CAUTION!

- When the cable insulation layer is chewed through, this can cause short circuits and potentially start an electrical fire. Therefore, where there is a risk of pests, rodents, or termites, protective barriers or additives are suggested to be added to the cables to prevent damage.

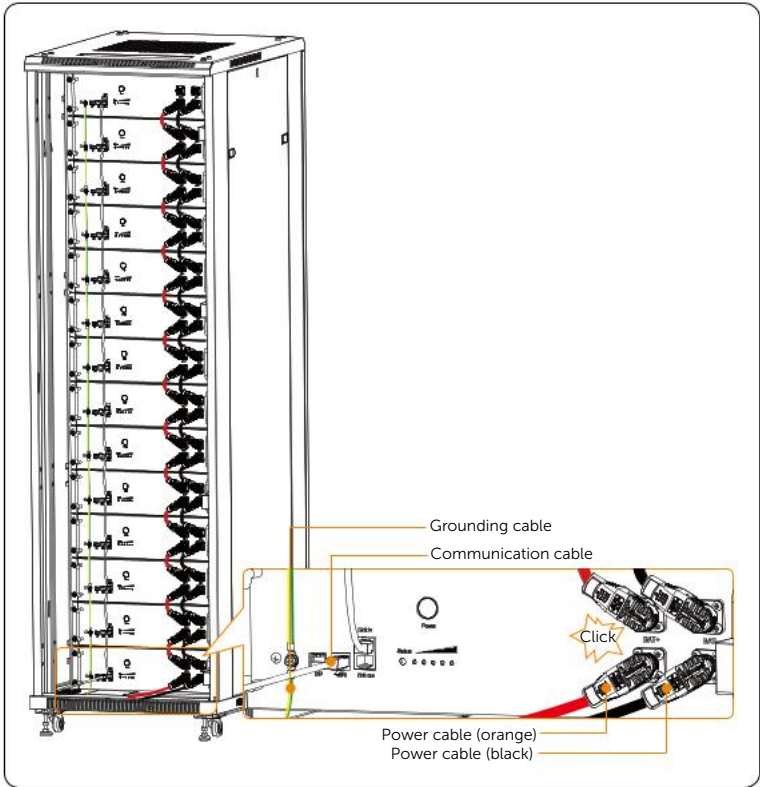

Figure 7-10 Connecting cables between the battery module and the inverter

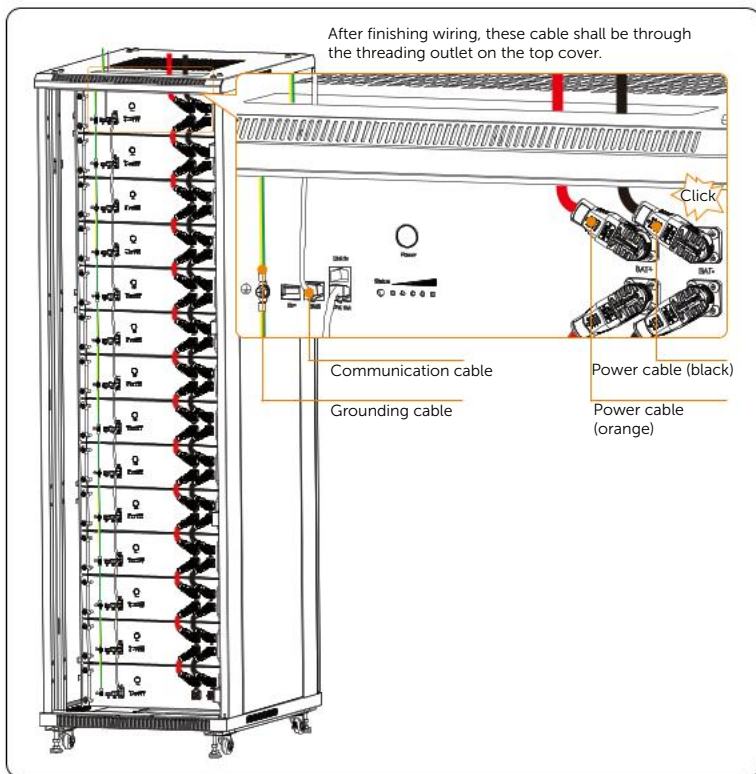
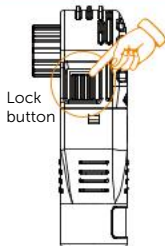

Figure 7-11 Connecting cables between the battery module and the inverter

NOTICE!



- Two terminals (see left figure) are equipped at both ends of power cables. Therefore, please press and hold the "Lock button" while unplugging the power cable. Otherwise, it cannot be pulled out.
- Don't violently remove the power cables when they are locked.

NOTICE!

- The connector on the power cable, connected to the inverter, is delivered with the inverter. Regarding the detailed assembly procedure, please refer to the inverter's *User Manual*.
- Users should hear the sound of "Click" while unplugging in the power cable. It indicates that the cable connector is properly plugged into the port.
- The "Link" port on the battery module is for parallel connections only. Don't use it for any other purposes.

7.4.3 Wiring Procedure about Wall Mounting

NOTICE!

- Regarding the wall mounting, up to 16 battery modules can be installed.
- The wiring procedure between battery modules are the same. Therefore, take the cable connection between two battery modules as an example.





Battery Module to Neighbouring Battery Module

NOTICE!

- The cables in the following table need to be purchased separately.

Table 7-7 Battery module to neighbouring battery module

Table 7-8

Cable	Length	Purpose	Qty
 Communication cable (Part C4)	700 mm	"Link in" port to "Link out" port	1 pc
 Power cable (black) (Part B4)	700 mm	"B-" port to "B-" port	1 pc
 Power cable (red) (Part A4)	700 mm	"B+" port to "B+" port	1 pc
 Grounding cable (Part D4)	700 mm	Grounding port to grounding port	1 pc

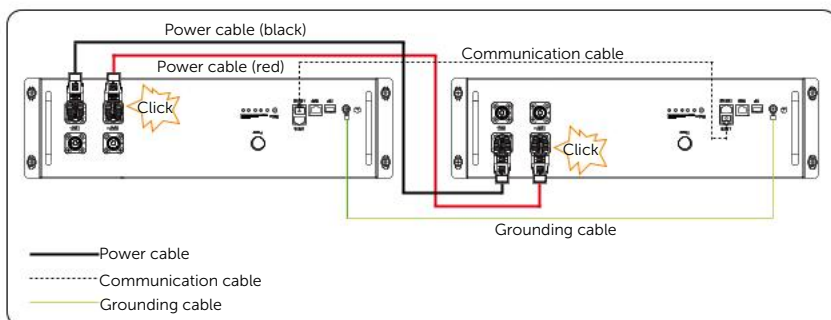
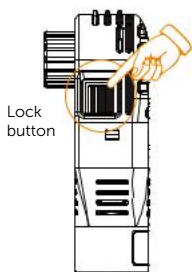

Figure 7-12 Cable connection between battery modules

NOTICE!







- Two terminals (see left figure) are equipped at both ends of power cables. Therefore, please press and hold the "Lock button" while unplugging the power cable. Otherwise, it cannot be pulled out.
- Don't violently remove the power cables when they are locked.

Battery Module to Inverter

NOTICE!

- Regarding the PE connection, please refer to "[PE Connection](#)".
- Regarding the communication connection, please refer to "[Communication Connection \(connecting to inverter\)](#)".
- The cables in the following table need to be purchased separately.

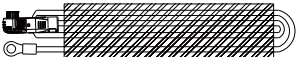
Table 7-9 Battery module to inverter

Cable	Length	Purpose	Qty
 Communication cable (Part C5)	2000 mm	"BMS" port to "BMS" port	1 pc
 Power cable (black) (Part B5)	2000 mm	"B-" port to "BAT-" port	1 pc
 Power cable (orange) (Part A5)	2000 mm	"B+" port to "BAT+" port	1 pc
 Ring terminal (Part D5)		Grounding port to grounding port	2 pcs

⚠ CAUTION!

- When the cable insulation layer is chewed through, this can cause short circuits and potentially start an electrical fire. Therefore, where there is a risk of pests, rodents, or termites, protective barriers or additives are suggested to be added to the cables to prevent damage.

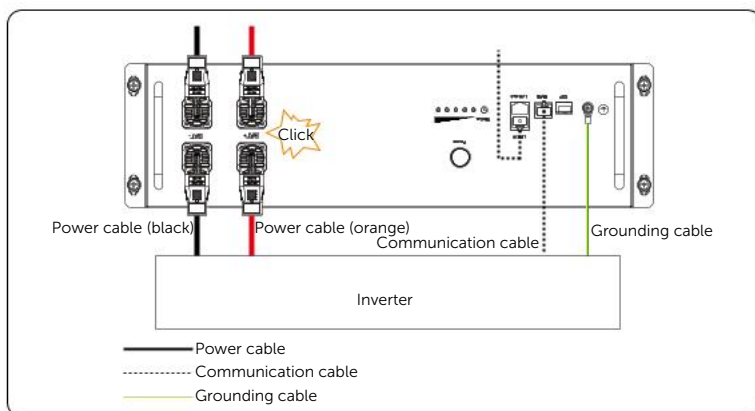
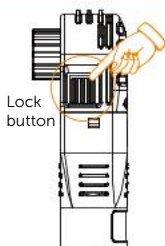

Figure 7-13 Connecting cables between the battery module and the inverter

NOTICE!



- Two terminals (see left figure) are equipped at both ends of power cables. Therefore, please press and hold the "Lock button" while unplugging the power cable. Otherwise, it cannot be pulled out.
- Don't violently remove the power cables when they are locked.

NOTICE!

- The connector on the power cable, connected to the inverter, is delivered with the inverter. Regarding the detailed assembly procedure, please refer to the inverter's *User Manual*.
- Users should hear the sound of "Click" while unplugging in the power cable. It indicates that the cable connector is properly plugged into the port.
- The "Link" port on the battery module is for parallel connections only. Don't use it for any other purposes.

8 Parallel Connection

8.1 Wiring of Parallel Connection

As for parallel connection, it may have to dismantle the inverter or the battery. In that case, please strictly follow the *User Manual* to remove or install.

- Please confirm that there is enough space to increase the number of battery clusters.
- Please make sure that the ground and wall that are used to install the new battery clusters can handle the additional weight.

The wiring diagram of the inverter, parallel box and inverter is shown as follows:

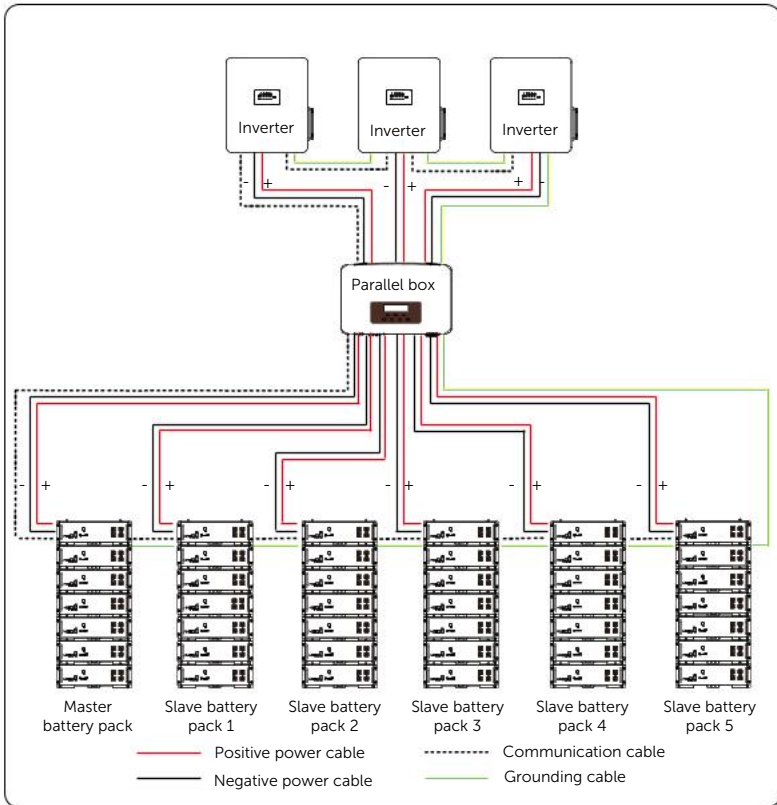

Figure 8-1 Wiring Diagram for Parallel Connection

8.2 Materials Requirement

The battery is allowed to be connected in parallel by installing parallel box. As for the parallel box and related cables, users need to provide for themselves on their actual needs.

Power Cable Requirement

In addition to power cables included in accessories kit, users may need to provide power cables for themselves according to different currents. The suitable power cables are as follows:

Table 8-1 Power cables for parallel connection

No.	Current (A)	Cross-sectional Area (mm ²)
1	200	≥50
2	250	≥70
3	300	≥95
4	400	≥120

Wiring Requirement for Cooper Bar of Parallel Box

NOTICE!

Requirements for the positive and negative copper bars:

- The recommended distance between the positive and negative copper bars is greater than 20mm.
- The recommended distance between wiring holes on the copper bars is greater than 40mm.
- To the capacity expansion for 6 battery clusters, the recommended cross-sectional area for the copper bars is 250 (50*5) mm².

NOTICE!

Requirements for the positive and negative power cables:

- The recommended length of the positive and negative power cables is less than 3m.
- The length of all power cables should be consistent.
- To the power cables connecting the battery, KST RNBL38-8 terminals are recommended for crimping.

9 Connection to the Third-party Inverter

9.1 Cable Connection

9.1.1 Connection of Capacity Expansion

WARNING!

- **Please confirm that the DIP switches 1~4 must stay in the "OFF" position before wiring, otherwise it will cause personal injury.** The DIP switches 1~4 will be slid to the "OFF" position and the DIP switch 5 will be slid to the "ON" position in the factory settings. For more details about the DIP switch, please refer to ["DIP Switch"](#).

- Step 1:** Connect the negative power cable to the "BAT-" ports of the master battery pack and inverter.
Connect the positive power cable to the "BAT+" ports of the master battery pack and inverter.
Connect the communication cable to the "BMS" ports of the master battery pack and inverter.
- Step 2:** Connect the negative power cable to the "BAT-" ports of adjacent battery packs.
Connect the positive power cable to the "BAT+" ports of adjacent battery packs.
Connect the communication cable to the "BMS" ports of adjacent battery packs.

NOTICE!

- For details about wiring procedure and wiring diagram, please refer to ["7.4 Wiring Procedure"](#).

9.1.2 Connection of Power Expansion

- Step 1:** Flip at least one of the DIP switches 1~4 of the master battery pack to the "ON" position. Do not operate the DIP switches of slave battery packs.
- Step 2:** Connect positive power cables to "B+" ports of all battery packs and inverter;
Connect negative power cables to "B-" ports of all battery packs and inverter.
Connect communication cables to the "BMS" ports of all battery packs and inverter.

NOTICE!

- For diagram after finishing wiring, please refer to "Figure 8-1 Wiring diagram of parallel connection"

9.2 Powering-on of the Third-party Inverter

First Commissioning

When first commissioning, users need to manually activate the black start before powering on to assign each battery module in a communication loop a unique address (battery number).

Please do as follows:

- Step 1:** Press and hold the "POWER" button on the master battery pack for 15 seconds. In the meantime, the status light will flash yellow, and the SOC power indicator will remain on solid green based on the battery module's actual battery capacity. At this point, release the button.
- Step 2:** The assignment will be completed when the status light flashes green every second. In the meantime, the battery will be automatically powered on.
- Step 3:** Press the "POWER" button three times within 10 seconds to ensure the battery remains powering on.
- Step 4:** All battery status lights will flash green every second after powering on.

After the First Commissioning

For powering-on steps after the first commissioning, please do as follows:

- Step 1:** Press the "POWER" button on the master battery pack for 2 seconds, and release it when the status light turns yellow.
- Step 2:** Wait for 15 seconds, and then the status light will be solid green.
- Step 3:** Within 10 seconds after turning solid green, press the "POWER" button three times to power on the battery.
- Step 4:** All battery status lights will flash green every second after powering on.

10 System Commissioning

10.1 Checking before Power-on

- a. Check the device installed correctly and securely;
- b. Make sure that Power button is OFF;
- c. All cables are connected correctly and securely;
- d. All unconnected port are covered;

10.2 Powering on the System

NOTICE!

- **Regarding the first start, after pressing and holding the POWER button on the battery module that connects to the inverter for 15 seconds, the battery system will assign each battery module in a communication loop a unique address (battery number).** In the meantime, the status light will flash yellow light, and the SOC power indicators will remain on solid yellow light based on the battery modules' actual battery capacity. At this point, release the button. After the unique address (battery number) is assigned, press the POWER button to shut down the system when the status light flashes green light and the SOC power indicators remains on solid yellow light.
- **Regarding the second start, after pressing the POWER button on the battery module that connects to the inverter for less than 3 seconds,** the status light remains on solid green light and the SOC power indicators remain on solid yellow light based on the battery modules' actual battery capacity. At this point, release the button.
- **In the event that the user wishes to increase or reduce the battery modules,** the system must be turned off. After completing the capacity expansion or reduction, press and hold the POWER button for more than 15 seconds to reassign each battery module in communication loop a unique address.
- A system problem may be encountered while pressing the button frequently. The user may need to wait at least 10 seconds and then try again.

Step 1: Press and hold the POWER button on the battery module that connects to the inverter.

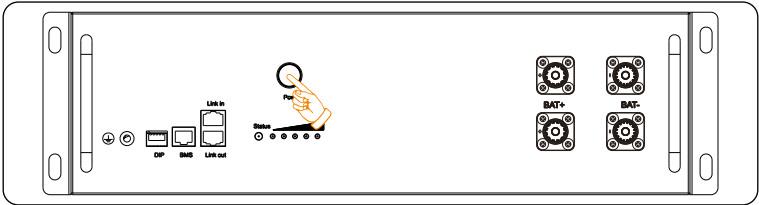

Figure 10-1 Power on

11 Troubleshooting and Maintenance

11.1 Power off the System

Step 1: Press and hold the POWER button.

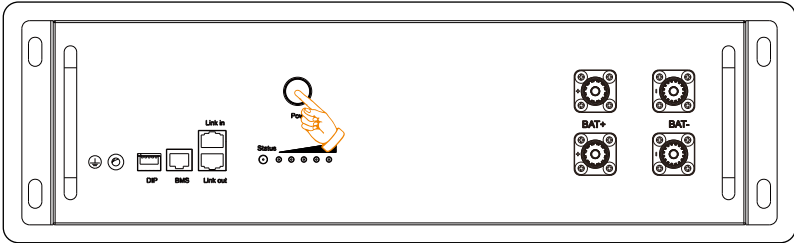

Figure 11-1 Power off

WARNING!

- After the battery powers off, there will still be the remaining electricity and heat which may cause electric shocks and body burns. Please wear personal protective equipment (PPE) and begin servicing the battery five minutes after power off.

11.2 Troubleshooting

This section contains information and procedures for resolving possible problems with the rechargeable battery and provides the troubleshooting tips to identify and solve most problems that may occur. Please conform the state of the indicators to check the status of the T-BAT system, check the warning or fault information via the monitoring software on the inverter, and read the suggested solutions below when error occurs.

In case of the following circumstances, e.g. voltage or temperature exceeds the limit specified, a warning state will be triggered.

The battery management system (BMS) of the T-BAT system will periodically report its operating state to the inverter. Therefore, when a warning is reported, the inverter will stop working immediately.

Contact SolaX Customer Service for further assistance. Please be prepared to describe the details of your system installation and provide the model and serial number of the rechargeable battery.

Error Code	Fault	Diagnosis and Solution
CellOverFault	Battery cell overvoltage fault	<p>Battery (cell) overvoltage:</p> <ul style="list-style-type: none"> • Tap "Power Off" on the inverter screen until the fault is rectified. • Contact the after-sales personnel of our company.
CellLowFault	Battery cell undervoltage fault	<p>Battery (cell) undervoltage:</p> <ul style="list-style-type: none"> • Make sure that the inverter is connected to the grid and that there is successful communication between the battery and inverter to ensure that the battery is charged. • Contact the after-sales personnel of our company.
CellDiffFault	The pressure difference between cells in the battery is too large	<p>The pressure difference between cells in the battery is too large:</p> <ul style="list-style-type: none"> • Restart the BMS. • Contact the after-sales personnel of our company.
HVBOverFault	Total voltage overvoltage fault	<p>Total voltage overvoltage:</p> <ul style="list-style-type: none"> • Tap "Power Off" on the inverter screen until the fault is rectified. • Contact the after-sales personnel of our company.

Error Code	Fault	Diagnosis and Solution
HVBLowFault	Total voltage undervoltage fault	<p>Total voltage undervoltage:</p> <ul style="list-style-type: none"> • Make sure that the inverter is connected to the grid and that there is successful communication between the battery and inverter to ensure that the battery is charged. • Contact the after-sales personnel of our company.
TempOverFault	High temperature of the BMS	<p>The temperature of the BMS is too high:</p> <ul style="list-style-type: none"> • Cool down the BMS to normal temperature, and then restart it. • Contact the after-sales personnel of our company.
TempLowFault	Low temperature of the BMS	<p>The temperature of the BMS is too low:</p> <ul style="list-style-type: none"> • Warm up the BMS to normal temperature, and then restart it. • Contact the after-sales personnel of our company.
SelfCheckFault	Self-test fault of the BMS	<p>Self-test fault of the BMS:</p> <ul style="list-style-type: none"> • Restart the BMS. • Contact the after-sales personnel of our company.
PreChgFailFault	BMS precharge failure fault	<p>External short circuit of the BMS:</p> <ul style="list-style-type: none"> • Check the external connection and restart the BMS. • Contact the after-sales personnel of our company.
TempSampleFault	Temperature sampling anomaly	<p>Temperature sampling anomaly:</p> <ul style="list-style-type: none"> • Restart the BMS. • Contact the after-sales personnel of our company.
SysFault	Slave control of abnormal current exists in the system	<p>Slave control of abnormal current exists in the system:</p> <ul style="list-style-type: none"> • Restart the BMS. • Contact the after-sales personnel of our company.
DsgOverFault	Discharge overcurrent of BMS	<p>Discharge overcurrent of BMS:</p> <ul style="list-style-type: none"> • Restart the BMS. • Contact the after-sales personnel of our company.

Error Code	Fault	Diagnosis and Solution
ChgOverFault	Overcurrent charging of BMS	Overcurrent charging of BMS: <ul style="list-style-type: none"> Restart the BMS. Contact the after-sales personnel of our company.
AFEComFault	AFE communication fault	AFE communication loss: <ul style="list-style-type: none"> Contact the after-sales personnel of our company.
MidComFault	The communication between the master and slave is abnormal	The communication between the master and slave is abnormal: <ul style="list-style-type: none"> Restart the BMS. Contact the after-sales personnel of our company.
VoltSensorFault	Voltage sensor fault	Voltage sampling fault of the BMS: <ul style="list-style-type: none"> Restart the BMS. Contact the after-sales personnel of our company.
IDRepeatFault	The slave controller with the same number exists in the system.	The slave controller with the same number exists in the system: <ul style="list-style-type: none"> Restart "Black Start". Contact the after-sales personnel of our company.
CurrSensorFlt	Current sensor fault	Current sampling fault of the BMS: <ul style="list-style-type: none"> Restart the BMS. Contact the after-sales personnel of our company.
LineFlt	The power cable is not properly plugged in.	Improper connection of the power cable: <ul style="list-style-type: none"> Rewire the power cables. Contact the after-sales personnel of our company.
FlashFlt	Flash fault	Flash fault: <ul style="list-style-type: none"> Contact the after-sales personnel of our company.
AFEProtectFlt	AFE self-protection failure	AFE self-protection failure: <ul style="list-style-type: none"> Contact the after-sales personnel of our company.

Error Code	Fault	Diagnosis and Solution
ChgReqFlt	Charging request not responded	<p>Inverter does not respond the charging request.</p> <ul style="list-style-type: none"> Restart the BMS or the inverter. Contact the after-sales personnel of our company.
BMS_LOST	Communication loss of the BMS	<p>Communication loss of the BMS:</p> <ul style="list-style-type: none"> Ensure that the communication cable is properly connected. Contact the after-sales personnel of our company.
ALM_ID_BAT_TYPR_CFG_ERR	Error of battery type	<p>Error of battery type:</p> <ul style="list-style-type: none"> Check whether the communication cable is properly connected after shutting down all the battery modules, and then restart Black Start.
ALM_ID_BATT_VOLT_HIGH	BMS overvoltage	<p>Overvoltage of a single battery module:</p> <ul style="list-style-type: none"> Contact the after-sales personnel of our company.
ALM_ID_BAT_BMS_CELL_FAULT	Battery cell fault of the BMS	<p>Battery cell fault of the BMS:</p> <ul style="list-style-type: none"> Check the fault carefully. Contact the after-sales personnel of our company.
ALM_ID_BAT_BMS_COMM_FAULT	BMS communication fault	<p>BMS communication fault:</p> <ul style="list-style-type: none"> Check the fault carefully. Contact the after-sales personnel of our company.
ALM_ID_BAT_CURR_HIGH	Battery current too high	<p>Too much current is drawn by a load:</p> <ul style="list-style-type: none"> Decrease the load power Contact the after-sales personnel of our company.
ALM_ID_BAT_SOC_LOW	Low SoC	<p>Low SoC:</p> <ul style="list-style-type: none"> Check the fault carefully. Contact the after-sales personnel of our company.

11.3 Maintenance

Regular maintenance is required for the rechargeable battery. Please pay attention to the following precautions for expressing the optimum device performance. More frequent maintenance service is needed in the worse work environment. Please make records of the maintenance.

Precautions

- If the ambient temperature for storage is between 30°C and 50°C (86°F to 122°F), please recharge the battery modules at least once every 6 months.
- If the ambient temperature for storage is between -20°C and 30°C (-4°F to 86°F), please recharge the battery modules at least once every 12 months.
- For the first installation, the interval among manufacture dates of battery modules shall not be exceed 3 months.
- If a battery module is replaced or added for capacity expansion, each battery's SOC should be consistent. The max. SOC difference should be $\pm 5\%$.
- If users want to increase their battery system capacity, please ensure that the SOC of the existing system capacity is about 40%. The manufacture date of the new battery module shall not exceed 6 months. If the manufacture date of the new one exceeds 6 months, please charge it to around 40%.

WARNING!

- Only qualified person can perform the maintenance for the rechargeable battery.
- Only use the spare parts and accessories approved by SolaX for maintenance.

12 Decommissioning

12.1 Disassembling the Battery

 **WARNING!**

- When disassembling the battery, strictly follow the steps as below.

Step 1: Press the POWER button to shut down the system.

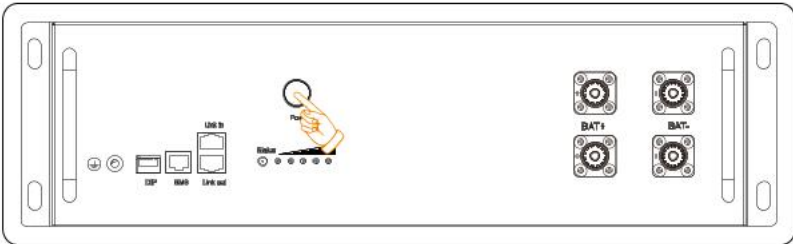

Figure 12-1 Pressing button and rotating switch

Step 2: Press and hold the lock button on the terminals to unplug the power cables.

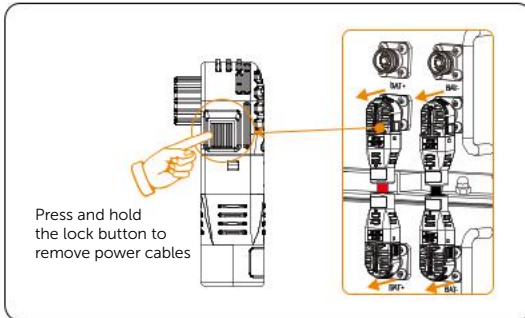

Figure 12-2 Unplugging power cables

Step 3: Remove the communication cable.

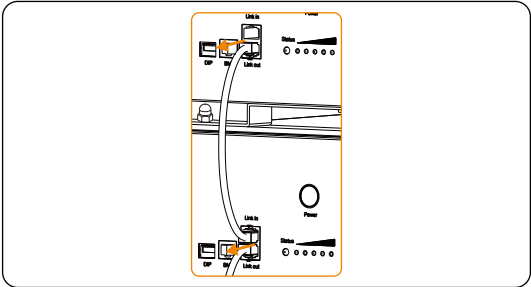

Figure 12-3 Removing communication cable

Step 4: Unscrew the screws to remove the grounding cable.

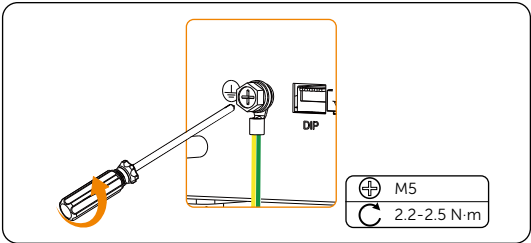

Figure 12-4 Removing grounding cable

12.2 Packing

- Load the battery module into the original packing material if possible.
- If the original packing material is not available, you can also use the packing material which meets the following requirements:
 - » Suitable for the weight of product.
 - » Easy to carry.
 - » Be capable of being closed completely.

12.3 Disposing of the Rechargeable Battery

Please dispose of the rechargeable battery or accessories in accordance with the disposal regulations for electronic waste which is applied at the installation site.

13 Technical Data

Parameter Display

Module	T-BAT LR25	T-BAT LR36
Nominal Voltage (Vdc)	51.2	51.2
Operating Voltage (Vdc)	45-58	45-58
Nominal Capacity (Ah) ¹	50	72
Nominal Energy (kWh) ¹	2.56	3.686
Usable Energy 90% DOD (kWh) ²	2.3	3.3
Max. Output Current (A) ³	50	50
Peak Charge/Discharge Current (A) ⁴	60 (60 seconds) / 100 (15 seconds)	
Battery Round-trip Efficiency (0.2C, 25°C)	95%	
Cycle Life 90% DOD (25°C)	6000 cycles	
Charge Temperature	0°C ~ 55°C	
Discharge Temperature	-20°C ~ 55°C	
Storage Temperature	30°C ~ 50°C (6 months); -20°C ~ 30°C (12 months)	
Ingress Protection	IP20	
Protection Class	I	

NOTICE!

1. Test conditions: 100% DOD, 0.2 C charge & discharge @ +25°C.
2. System usable energy may vary with inverter different setting.
3. Discharge: In case of battery cell's temperature range of -20°C ~ 10°C and 45°C ~ 55°C, the discharge current will be reduced;
Charge: In case of battery cell's temperature range of 0°C ~ 25°C and 45°C ~ 55°C, the charge current will be reduced. Product charge or discharge power depends on the actual temperature of the battery cell.
4. The battery can only be discharged and cannot be charged when the battery cell's temperature range is between -20°C and 0°C.

Contact Information



UNITED KINGDOM

- 📍 Unit C-D Riversdale House, Riversdale Road, Atherstone, CV9 1FA
- ☎ +44 (0) 2476 586 998
- ✉ service.uk@solaxpower.com



TURKEY

- 📍 Fevzi Çakmak mah. aslim cd. no 88 A Karatay / Konya / Türkiye
- ✉ service.tr@solaxpower.com



USA

- 📍 3780 Kilroy Airport Way, Suite 200, Long Beach, CA, US 90806
- ☎ +1 (408) 690 9464
- ✉ info@solaxpower.com



POLAND

- 📍 WARSAW AL. JANA P. II 27. POST
- ☎ +48 662 430 292
- ✉ service.pl@solaxpower.com



ITALY

- ☎ +39 011 19800998
- ✉ support@solaxpower.it



PAKISTAN

- ✉ service.pk@solaxpower.com



AUSTRALIA

- 📍 21 Nicholas Dr, Dandenong South VIC 3175
- ☎ +61 1300 476 529
- ✉ service@solaxpower.com.au



GERMANY

- 📍 Am Tullnaupark 8, 90402 Nürnberg, Germany
- ☎ +49 (0) 6142 4091 664
- ✉ service.eu@solaxpower.com
- ✉ service.dach@solaxpower.com



NETHERLANDS

- 📍 Twekkeler-Es 15 7547 ST Enschede
- ☎ +31 (0) 8527 37932
- ✉ service.eu@solaxpower.com
- ✉ service.bnl@solaxpower.com



SPAIN

- ☎ +34 9373 79607
- ✉ tecnico@solaxpower.com



BRAZIL

- ☎ +55 (34) 9667 0319
- ✉ info@solaxpower.com



SOUTH AFRICA

- ✉ service.za@solaxpower.com



SolaX Power Network Technology (Zhejiang) Co., Ltd.

Add.: No. 278, Shizhu Road, Chengnan Sub-district, Tonglu County,
Hangzhou, Zhejiang, China
E-mail: info@solaxpower.com

