



TP

User Manual

Version 0.0

www.solaxpower.com

STATEMENT

Copyright

Copyright © SolaX Power Technology (Zhejiang) Co., Ltd. All rights reserved.

No part of this manual may be reproduced, transmitted, transcribed, stored in a retrieval system, or translated into any language or computer language, in any form or by any means without the prior written permission of SolaX Power Technology (Zhejiang) Co., Ltd.

Trademarks



and other symbol or design (brand name, logo) that distinguishes the products or services offered by SolaX has been trademark protected. Any unauthorized use of above stated trademark may infringe the trademark right.

Notice

All or part(s) of the products, features and services described in this document may not be within your scope of purchase or usage. Unless otherwise specified in the contract, the contents, information and recommendations in this document are provided as is, SolaX makes no kind of warranties, guarantees or representations expressly or implicitly.

The content of the documents is continually reviewed and amended, where necessary. However, discrepancies cannot be excluded. SolaX reserves the right to make improvements or changes in the product(s) and the program(s) described in this manual at any time without the prior notice.

The images contained in this document are for illustrative purposes only and may vary depending on product models.

Please visit the website www.solaxpower.com of SolaX Power Technology (Zhejiang) Co., Ltd. for more information.

SolaX reserves all the right for the final explanation.

About This Manual

Scope of Validity

This manual is an integral part of TRENE-P100B215I. It describes the transportation, storage, installation, electrical connection, commissioning, maintenance and troubleshooting of the product. Please read it carefully before operating.

Model Code

TRENE-P100B215I



No.	Definition	Description
1	Product name	TRENE: Refer to the name of AC couple series project.
2	Power	P100: Indicate that the rate power of the inverter is 100 kW.
3	Battery capacity	B215: Indicate that the battery capacity is 215 kWh.
4	Inverter model	I: Refer to an embedded inverter.

Target Group



The installation, maintenance and grid connection setting can only be performed by qualified personnel who

- Are licensed and/or satisfy state and local jurisdiction regulations.
- Have good knowledge of this manual and other related documents.
- A medium-voltage operator is required to obtain any Certifications for High-voltage Electrician.

Conventions

To help users better understand the *Manual*, the explanations for the format and symbols herein are shown as follows:

Format	Description
">"	">" represents that there are multiple selections. For example, the process of "Tap 'Settings' and then Tap 'User Setting'" will be represented in "'Settings'" > 'User Setting'".
" "	Radio buttons, checkboxes, and buttons will show with double quotation marks (" "). For example, tap "OK" button.

Symbol	Description
 DANGER	Indicates a hazardous situation which, if not avoided, will result in death or serious injury.
 WARNING	Indicates a hazardous situation which, if not avoided, could result in death or serious injury.
 CAUTION!	Indicates a hazardous situation which, if not avoided, could result in minor or moderate injury.
NOTICE!	Provides tips for the optimal operation of the product.

Change History

Version 00 (, 2024)

Initial release

Table of Contents

- 1 Safety 1
 - 1.1 General Safety 1
 - 1.2 Personal Safety 2
 - 1.3 Environment Requirement 3
 - 1.4 Cabinet, Battery and Electric Safety 4
 - 1.4.1 Cabinet Safety 4
 - 1.4.2 Battery Safety 7
 - 1.4.3 Electrical Safety 11
- 2 Product Overview 15
 - 2.1 Product Introduction 15
 - 2.1.1 Features 15
 - 2.2 Cabinet Overview 16
 - 2.2.1 Appearance and Dimension 16
 - 2.2.2 Parts Description 18
 - 2.3 High-voltage Box 23
 - 2.4 Battery Pack 24
 - 2.5 Distribution Box 26
 - 2.6 IO Module 28
 - 2.7 Other Parts 29
 - 2.7.1 Air Conditioner 29
 - 2.7.2 Automatic Fire Sprinkler 29
 - 2.7.3 Temperature Sensor 29
 - 2.7.4 Smoke Detector 30
 - 2.7.5 CO Detector 30
 - 2.7.6 Temperature and Humidity Sensor 30
 - 2.7.7 Audible and Visible Alarm 31
 - 2.7.8 Water Sensor 31
 - 2.7.9 Door sensor 31
 - 2.8 Operating Principle 32
 - 2.8.1 Electrical Block Diagram 32
 - 2.8.2 Indicator 34
 - 2.9 Symbols 36
- 3 Transportation and Storage 38
 - 3.1 Transportation Requirements 38

- 3.2 Storage Requirements40
 - 3.2.1 Cabinet Storage40
 - 3.2.2 Battery Pack Storage41
- 4 Preparation before Installation..... 42**
 - 4.1 Installation Site Selection42
 - 4.1.1 Installation Environment Requirements45
 - 4.1.2 Installation Foundation Requirements46
 - 4.1.3 Forklift Requirements48
 - 4.1.4 Hoisting Requirements48
 - 4.1.5 Clearance Requirement49
 - 4.2 Tools Requirement.....50
 - 4.3 Additionally Required Materials52
- 5 Unpacking and Inspection 53**
 - 5.1 Unpacking.....53
 - 5.2 Packing List.....53
- 6 Mechanical Installation 56**
 - 6.1 Installation of Eye Bolt (Optional)56
 - 6.2 Fork Position.....58
 - 6.3 Antenna Installation59
 - 6.4 Installation Dimensions.....60
 - 6.5 Installation Procedure for Angle Support and Cover61
- 7 Electrical Connection 64**
 - 7.1 Operation before Connection.....64
 - 7.2 Grid Connection66
 - 7.3 Grounding Plate Connection.....72
- 8 Commissioning 74**
 - 8.1 Check before Power On.....74
 - 8.2 Power ON75
- 9 Troubleshooting and Maintenance 78**
 - 9.1 Power Off.....78
 - 9.2 Troubleshooting.....82
 - 9.3 Maintenance.....87
 - 9.3.1 Maintenance Routine88
 - 9.3.2 Disassembly and Clean of Air Conditioner Filter90
 - 9.3.3 Maintenance of Battery Pack90
- 10 Dispose of Wasted and Damaged Battery Pack 91**

11 Technical Data 92

12 Appendix 94

 12.1 How to Repaint the Cabinet.....94

1 Safety

1.1 General Safety

Before transporting, storing, installing, operating, using and/or maintaining the equipment, please carefully read the document, and strictly follow the instructions and safety precautions given herein, as well as symbols affixed on the equipment.

The operator should not only abide by all safety precautions provided in the document, including but not limited to the "Danger" sign, "Warning" sign, "Caution" sign, and "Notice" sign, but also comply with relevant international, national and local laws and regulations, and industry rules. **SolaX will not assume any responsibilities for the loss caused by improper operation, or violation of safety standards for design, production and equipment suitability.**

SolaX will not be liable for maintenance for possible device failure, device malfunction, or parts damage, nor **will the company assume any liability to pay compensation for the possible physical and property damage** resulting from the installation environment that does not meet the design requirements.

The operator should comply with the local laws, regulations, standards and guidelines in the process of transportation, storage, installation, operation, and maintenance.

The device is well designed and tested to meet all applicable states and international safety standards. However, like all electrical and electronic equipment, safety precautions must be observed and followed during the installation of the device to reduce the risk of personal injury and to ensure a safe installation.

Before installing the device, carefully read, fully understand and strictly follow the detailed instruction of the *User Manual* and other related regulations. And the safety instructions in this document are only supplements to local laws and regulations.

SolaX will not assume any responsibilities if any of the following circumstances occurs, including but not limited to:

- Device damage due to force majeure, such as earthquake, flooding, thunderstorm, lighting, fire hazard, volcanic eruption, war, typhoon, tornado, etc.
- Device damage due to man-made cause.
- Device used or operated against local policy or regulations.
- Failure to follow the operation instructions and safety precautions on the product and in this document.
- Installation and use under improper environment or electrical condition.
- Unauthorized modifications to the product or software.
- Device damage caused during transportation by the customer or the third party.
- Storage conditions that do not meet the requirements specified in this document

- Use of incompatible inverters or devices.
- Installation and commissioning operated by unauthorized personnel who are not licensed and /or satisfy state and local jurisdiction regulations.

1.2 Personal Safety

DANGER!

- Do not power on while installing the device. If the device is powered on in the process of installation and disassembly of cables, an electric arc, electric spark or fire will occur at the moment that the cable core contacts conductors. It may cause a fire or result in physical and property damage.
- Do not improperly operate while powering on. Any improper operation may cause a fire, electric shock, or explosion, and it will result in physical and property damage.
- Must remove rings, bracelets, watches, and any other metal jewelry from fingers, hands, or wrists before operation, to avoid electrical shock or burn.
- Must use special insulation tools, of which the insulation grade and dielectric strength level must be consistent with local laws, regulations, standards, and guidelines, in the operation process, to avoid electrical shock, burn, or short circuit fault.

WARNING!

- Must wear special personal protective equipment (PPE), such as a coverall, safety boots, safety glasses, safety helmet, safety gloves, etc.

CAUTION!

- Do not stop the safety switch on the equipment, and neglect the "Danger" sign, "Warning" sign, "Caution" sign, and "Notice" sign on the equipment, as well as safety precautions in the document.
- Must stop working at once, report to the relevant person in charge, and activate protection schemes in case of possible danger that may cause human injury and damage to equipment in the installation and operation process.
- Do not power on during the installation process, or before obtaining confirmation from professionals after finishing installation.
- Do not directly contact power supply equipment, or contact it with other conductors or wet objects.
- Do not touch the running fan with parts, screws, or installation tools, or keep hands clear when the fan is running, to avoid personal injury or property damage.
- Please evacuate and press the fire bell immediately, or call fire department at once in the case of a fire.

1.3 Environment Requirement

DANGER!

The equipment installation site shall meet the following requirements:

- Keep away from combustibles and explosive materials.
- Keep away from heat or fire sources, such as fireworks, candles, heaters, or any other heat-producing appliances. It may cause damage to equipment or a fire.
- Keep away from flammable and explosive gases, or smoky environments.

WARNING!

- The equipment installation site should keep away from liquid areas, such as positions under a water pipe or air outlet where the condensed water is easy to form, or positions under an air-conditioning vent, ventilation opening or equipment room outlet where there is access to water. The water can seep into the internal components of the device, causing device damage and short circuits.
- Do not cover vents and cooling systems while running. Otherwise, it may cause a fire or equipment damage due to the high temperature.

CAUTION!

- The storage area should be clean, dry, and well ventilated to prevent dust from entering, and condensed water from generating.
- Strictly observe technical specifications while installing and running the equipment. Or, it may affect the performance and safety of the equipment.
- Do not install, run or operate outdoor equipment or cables (including but not limited to carrying equipment, operating equipment, connecting cables, plugging or unplugging cables that connect to outdoor signal ports, working at heights, outdoor installation, etc.) in bad weather, such as thunderstorms, rain, snow, etc.
- Keep away from the following environments while installing the equipment: environments with dust, smoke, volatile gases, corrosive gases, infrared radiation, organic solvents, or a site with high salt.
- Keep away from environments with metal-conductive or magnetic-conductive dust.
- Keep away from areas suitable for fungus, mould, or other microorganism growth.
- Keep away from areas with strong shaking, serious noise pollution, or powerful electromagnetic interference.
- The installation site must conform to local laws and regulations, and relevant standards.
- The ground at the installation site must be firm and strong instead of having an adverse geological condition, such as soil with high water content, weak soils, or loose soils. And keep away from low-lying areas since they are prone to water or snow accumulation.
- Keep away from areas prone to water accumulation.
- If the equipment is installed on a grassy plantation, do weed regularly, and harden the ground under the equipment, such as cementing, gravelling, etc.

 CAUTION!

- When the operator plans to install, operate or maintain the equipment, water, snow, or other objects must be cleared on the top of the device before opening doors to keep them from entering into the device.
- Please check the ground is firm and strong enough to meet the load-bearing requirements of the equipment while it is being installed.
- Must seal the entry holes.
- Must clean the packing materials, such as cartons, foams, plastic bags, ties, etc., on the site after finishing installation.

1.4 Cabinet, Battery and Electric Safety

To prevent personal injury or property damage from improper operation, please carefully read the following installation precautions before installation.

1.4.1 Cabinet Safety

 DANGER!

- A safety helmet, belt, or rope must be worn when performing work at height. If the safety rope is adopted, one end must be securely tied to a strong structural part instead of a movable and unsound object or a metal with sharp edges, to prevent fall incidents due to the slip of the rope hook.

 WARNING!

- To ensure that a complete set of tools is prepared, are firm and secure. They must pass the verification of professional authorities. DO NOT use any tools that are broken, failed to verify, or are expired.
- To prevent personal injury or equipment damage from slopping or collapsing of the cabinet because it is unstable, please check if the cabinet has been secured before placing any devices into it.
- To protect relevant people from injury, take care of the unstable or heavy devices in the cabinet when taking them out.
- Do not drill holes in the equipment. Otherwise, the sealing performance, electromagnetic shielding performance, or internal components or cables of the equipment will be destroyed, and it can even cause a short circuit on a circuit board if the metal dust generated by drilling enters into the device.

 CAUTION!

Safety precautions for lifting and handling heavy devices:

- To prevent injury from oversize loads, assess the device you're about to lift before you start lifting.
- If more than 2 people lift a device, reasonably arrange to have a balanced weight distribution
- Wear personal protective equipment, such as, safety gloves, safety boots, etc., to prevent needless injuries when lifting devices with bare hands.
- Know the right body posture to prevent personal injuries when lifting devices, for instance, bend at your knees, not at your waist or back, and do not twist your back.
- Hold the handles on the device or put your hands underneath the device to move or lift, and do not hold the handles on the parts installed in it.
- To prevent injuries, do not quickly lift the heavy device above the waist.
- To prevent scratches and dents, or damage to components and cables, avoid impact and falling when moving.
- Be aware of workbenches, slopes, steps, and other places where it is easy to slip when moving devices. Ensure that the passageways are smooth, clean, and away from obstacles.
- To prevent tipover, the forklift's forks must be placed under the load. Center the weight of the load between the forks, and adjust the forks to distribute the weight evenly. Firmly attach the loads to the forks before lifting, and arrange for people to watch for when lifting.
- Sea and road (in good condition) transports are an idea for the device instead of rail and air transports. Transport staff should do their best to avoid bumpiness and inclination as much as possible.

 CAUTION!

Safety precautions for working at heights:

- Arrange people to protect workers who work at 2 meters in height or higher.
- Workers who work at 2 meters in height or higher are required to be trained and obtain relevant qualifications.
- In the case of one of the following circumstances, workers should immediately stop operation until the device is inspected and confirmed safe by the relevant safety director and technicians.
 1. Wet steel pipe.
 2. Other situations may be dangerous.
- Should mark off a dangerous area, put up Danger signs, and keep unauthorized people from entering the area.
- Should install guardrails and put up "Watch Your Step" and Danger signs at the edges of workplace and holes.
- Do not stack scaffoldings, gangplanks, or other sundries, and keep the ground service staff from staying or passing under the area where the work is being carried out.
- Take caution with the apparatus and tools brought to ensure that they do not fall.

Continued to the next page

 CAUTION!

Safety precautions for working at heights:

- Workers who work at heights should take advantage of crane slings, baskets, elevating transfer vehicles, cranes, or other methods to transfer objects instead of throwing them from the air to the ground or from the ground to the air.
- Should avoid working on the up and down work platform at the same time. Or, a special protective shed should be built or some protective measures should be taken between two work platforms to protect workers. In addition, do not stack tools and materials on the upper work platform.
- The scaffoldings should be removed from top to bottom instead of being removed at the same time after finishing installation. Take caution when dismantling parts of scaffolding.
- Workers who work at heights must abide by the Safety Regulation for Working at Heights. SolaX will not be liable for personal injury or equipment damage due to violations of the Regulation.
- Do not play and have a break in the area while working at heights.

 CAUTION!

Ladder safety:

- A wood or insulated ladder should be used when working with electricity.
- A platform ladder with handrails is preferred instead of a straight ladder.
- Check that the ladder is in good condition, make sure that the load bearing meets requirements, and strictly prohibit overload.
- Place the ladder on a solid and firm surface, and designate a person to hold it.
- Balance your body to prevent injuries when climbing.
- Make sure that the rope is fastened and secured when using the herringbone ladder to prevent incidents.

 CAUTION!

Crane safety:

- Crane operators are required to be adequately trained, and certified and licensed to operate said equipment before starting work.
- Must install guardrails and put up Warning signs at the crane working area.
- The groundwork for the hoisting operation must meet the load bearing requirements of the crane.
- Make sure that the hoisting tools have been secured to an object or wall that meets the load bearing requirements before hoisting.
- Keep the ground service staff from staying or passing under the crane boom or suspended load where the work is being carried out.
- Do not drag steel wire rope, wire rope slings, etc., and hit hoisting equipment with hard objects, when hoisting work is being carried out.
- Make sure that the angle between two wire ropes do not exceed 90° when hoisting.

 CAUTION!**Drilling safety:**

- Wear personal protective equipment when drilling, such as safety glasses, safety gloves, etc.
- Avoid drilling around pipes, and light switches and sockets, as the electrical wires can go horizontally and vertically around these fixtures.
- Cover the device to protect it from dusts and debris entering when drilling, and clean it at once after finishing drilling.

1.4.2 Battery Safety

 DANGER!

- Do not connect the positive and negative poles of a battery together. Or, the battery may be short-circuited. A short circuit may cause enormous amounts of current and release large quantities of energy for a short time, which may cause the battery to leak, smoke, release flammable gases, or be in thermal runaway, catch fire, or explode. Therefore, power off the battery before maintenance.
- Overheating the battery can lead to significant risks, including leakage, smoke, release of flammable gases, thermal runaway, fire, or explosion. In case of one of the following circumstances, do not install battery:
 - a. Direct sunlight
 - b. Fire source
 - c. Heater
 - d. Others conditions that can cause overheating
- Never damage the device by crushing, deforming, dropping, impacting, cutting or penetrating with a sharp object. Otherwise, it may cause a fire or leakage of electrolytes;
- Never dismantle, change or damage battery, including penetrating with a sharp object, deforming, soaking in water or other liquids, to keep it away from leakage, smoke, release of flammable gases, thermal runaway, fire or explosion.
- Do not touch battery terminals with any other metal objects, which may cause heat or leak.
- Do not mix different types or makes of the battery pack. It may cause leakage or rupture, resulting in personal injury or property damage.
- The battery electrolyte is toxic and volatile. Never get contact with the leaked liquids or inhale gases in the case of the battery leakage or odor. In such a case, keep away from the battery and contact professionals immediately. Those professionals must wear PPE, such as safety glasses, safety gloves, gas masks, protective clothing, etc., power off the equipment, remove the battery, and contact technical engineers.

Continued to the next page

 **DANGER!**

- Normally, the battery will not release any gases since it is an enclosed system. However, in the following situations: burnt, needle-pricked, squeezed, struck by lightning, overcharged, or subject to other adverse conditions that may cause battery thermal runaway, the battery may be damaged or an abnormal chemical reaction may occur inside the battery, resulting in electrolyte leakage or production of gases. To prevent fire or device corrosion, ensure that flammable gas is properly exhausted.
- Take steps to protect human beings from the gases released when burning the batteries.

 **WARNING!**

- Install batteries in a dry area. Do not install them under areas prone to water leakage, such as air conditioner vents, ventilation vents, feeder windows of the equipment room, or water pipes. Ensure that no liquid enters the equipment to prevent faults or short circuits.
- Equip with fire-fighting equipment, such as dry sand, carbon dioxide fire extinguisher, etc., when installing and commissioning according to construction standards and requirements. Make sure that the above-mentioned fire-fighting equipment conforms to local laws, regulations and standards.
- Before unpacking, and in the process of storage and transportation, ensure that the packing cabinets are intact and the batteries are correctly placed according to the labels on the packing cabinets. Do not place a battery upside down or vertically, lay it on one side, or tilt it. Stack the batteries according to the stacking requirements on the packing cabinets. Make sure that the batteries do not fall or get damaged. Otherwise, they will need to be scrapped.
- After packing, the batteries must be correctly placed in accordance with the requirements. Do not place a battery upside down or vertically, lay it on one side, or tilt or stack it. Make sure that the batteries do not impact, fall get damaged. Otherwise, they will need to be scrapped.
- Tighten the screws on copper bars or cables to the torque specified in this document. Periodically confirm whether the screws are tightened, check for rust, corrosion, or other foreign objects, and clean them up if any. Loose screw connections will result in excessive voltage drops and batteries may catch fire when the current is high.
- After batteries are discharged, charge them in time to avoid damage due to overdischarge.

 **CAUTION!**

- Please read the document carefully before installation, operation and maintenance.
- Charge the battery within the specific temperature range because the low temperature may result in short circuit. Hence, do not charge the battery if the temperature is below the low limit of the operating temperature.
- Ensure that the packing cabinets are intact before unpacking. Do not use if package is damaged, and contact forwarder and manufacturer immediately.

Continued to the next page

 CAUTION!

- May leak electrolytes or release flammable gases if the battery is damaged, including dropping, crashing, bulging, or housing indentation. Do not use in the case of the above-mentioned circumstances. Please immediately contact the installer or professional operation and maintenance staff to remove or change the battery in the case of leakage of electrolytes or structural distortion. Keep the damaged battery away from other devices or inflammable and explosive materials, and ensure that non-professional personnel do not contact the damaged batteries.
- Ensure that the pungent and burning smells go away before operating.
- Do not place any objects, like tools, metal parts, etc., on top of the battery. Check and clean them up if any.
- Do not install batteries in rain, snow, fog, or other extreme weather, to prevent moisture or corrosion.
- Do not install batteries after moisturizing, transport to an isolation area, and be scrapped.
- Check if the shell of the battery is deformed or damaged before installing. If yes, do not install it.
- Check whether the positive and negative terminals of the battery are accidentally grounded. If yes, disconnect them.
- Do not weld or grind near the battery. Because an electric spark or arc may cause a fire.
- Store or recharge the battery according to the document if it is not used for a long time.
- The devices used to charge or discharge the batteries must meet the requirements of local laws, regulations, and standards.
- Power off the battery when installing and maintaining.
- Inspect the damaged battery to ensure that there is no smoke, fire, leakage of electrolytes, or heat in the period of storage.
- Do not touch the battery when it fails because of the high temperature of the surface.
- Do not step, against, or stand on the battery.
- The batteries are not allowed to be used to provide a backup power source in the following circumstances:
 - a. Medical equipment that is directly related to human health.
 - b. Equipment, like trains, elevators, etc., that may cause injuries to human beings.
 - c. Computer systems that play an important role in societies and institutions.
 - d. Nearby area with medical equipment.
 - e. Other devices that play a similar role, as described above.

NOTICE!

Short-circuit protection

- Use electrical tape to wrap the exposed wire outwards to prevent short circuit when installing and maintaining.
- Prevent any object from entering into batteries.

NOTICE!

In case the battery pack leaks electrolyte or any other chemical materials, or gas may be generated due to the leakage of battery pack, be sure to avoid contact with the discharge at all times. In case of accidentally coming into contact with them, please do as follows:

- In case of inhalation: Leave the contaminated area immediately, and seek medical attention at once;
- In case of contact with eyes: Rinse eyes with running water for 15 minutes, and seek medical attention;
- In case of contact with skin: Wash the contacted area thoroughly with soap, and seek medical attention;
- In case of ingestion: Induce vomiting, and seek medical attention.

NOTICE!

If a fire breaks out where the battery pack is installed, please do as follows:

- In case the battery pack is charging when the fire breaks out, provide it is safe to do so, disconnect the battery pack circuit break to shut off the power charge;
- In case the device is not on fire yet, use a Class ABC fire extinguisher or a carbon dioxide extinguisher to extinguish the fire;
- If the battery pack catches fire, do not try to put out the fire, and evacuate immediately. Others conditions that can cause overheating.
- The battery pack may catch fire when it is heated above 302°F/60°C; and in case of catching fire, it will produce noxious and poisonous gas, DO not approach and keep away.

NOTICE!

Effective ways to deal with accidents:

- In case of the damaged battery pack, place it into a segregated place, and call the local fire department at the place where the user lives or qualified personnel.
- If any part of the battery pack, or wiring is submerged, do stay out of the water and do not touch anything; If the battery pack gets wet, don't touch it.
- If the battery pack is damaged, don't use it. Otherwise, it may result in both personal injury and property damage.
- Don't use the submerged battery pack again, and contact the qualified personnel

NOTICE!**Recovery of damaged or wasted battery:**

- Dispose of the damaged or wasted batteries according to local laws and regulations instead of placing them in the household trash or in curbside recycling bins. Otherwise, it may cause environmental pollution or explosions.
- Contact our company or a battery recycling company to scrap the battery, if it leaks electrolytes, or is damaged.
- Contact a battery recycling company to scrap batteries if they are expired.
- Keep the damaged or wasted batteries away from high temperatures and direct sunlight.
- Ensure that the damaged or wasted batteries are not exposed to the following environments: high humidity, corrosion.
- Do not recycle the damaged or wasted batteries for a second use, and immediately contact a battery recycling company to scrap them. Or, it may cause environmental pollution.

1.4.3 Electrical Safety

 DANGER!

- Before wiring, check that the device is intact to prevent electric shock or a fire.
- Improper operation may cause a fire, electric shock, etc.
- Prevent any objects from entering into the device when operating. Otherwise, the device may be short-circuited or damaged, the load's power supply may be derated or powered off, or personal injuries may occur.

 WARNING!

- A device required to be grounding must be grounded firstly when conducting wiring. The PNGD cable must be disconnected finally after removing any other cables.

 CAUTION!

- Do not install cables near air inlet (or outlet) of the device.

NOTICE!

- Please strictly follow the steps described in the document before installing, operating and maintaining the device. Do not modify or change the device, and adjust the installation procedure.
- Permission shall be obtained from the state or local electrical department before conducting the grid connection.
- Abide by the safety regulations stipulated by the power station.
- Mark off an operation area, install a temporary fencing or rope, and put up "No Entry" signs.
- Power off the device and shut down switches before connecting or disconnecting power cables.
- Power off the device at once and do not use again if there are any liquids entering into it.
- Check and confirm whether the tools meet the requirements described in the document before operating the device, and be registered. Check whether the number of tools is correct after installing and operating it.
- Check that the icons on the cable labels are correct before connecting power cables. Ensure that the terminals are completely covered with insulation.
- Ensure that protective shell or insulation sleeving on the electrical components are correctly installed to protect operators from electric shock.
- In the case of multiple inputs, disconnect them first; do not operate the device until it is completely powered off.
- Turn off the corresponding output switch of the power supply equipment while maintaining electrical terminal equipment and power distribution equipment connected to the power supply equipment.
- Must put up "Do Not Switch On" signs and warning signs, to prevent power connection. Do not switch on before the fault is repaired.
- Must follow the steps below if the device needs a power cut in the process of fault diagnosis and troubleshooting: power cut > electricity testing > connecting grounding cable > putting up warning signs and installing guardrails.
- Periodically check whether the screws are tightened fully.
- Only professionals can change the damaged cables.
- Do not alter, damage or obscure the logos and labels attached to the devices.
- Do not clean the internal and external parts of the device with solvents, like water, alcohol or oil.

NOTICE!**Grounding requirement:**

- The equipment grounding impedance shall meet the requirements of the local electrical code.
- The equipment shall be permanently connected to a grounding wire within the building's electrical system. Check that the equipment is reliably grounded.
- Do not operate the equipment before connecting it to the equipment grounding connector.
- Do not damage the equipment grounding connector.
- Make sure that the grounding pin in the 3 pin plug is connected to a grounding wire within the building's electrical system in the case of the 3 pin plug.
- In the case of high-current equipment, it shall be ensured that the protective grounding terminal of the device shell has been grounded.

NOTICE!**Wiring requirement:**

- Must abide by the local laws, regulations and standards to select, install, and route cables.
- Do not circle or twist cables. Change the power cable if the cable length is insufficient instead of joining it.
- Make sure that cables are secured and well-insulated, and meet specifications.
- Cable troughs or holes must be smooth, burr-free working surface to prevent cable damage.
- Suggest to use cable ties to bind cables to ensure that the cables inside the cabinet are tidied, and to prevent cable jacket damage. Do not circle or twist cables.
- Use fireproofing mud immediately to seal the cable holes if you need to leave for a while after finishing wiring or in the process of wiring, to prevent water vapor and small animals.
- If the external conditions (routing method, temperature, etc.) change, the cable type must be verified according to IEC-60364-5-52 or local laws, regulations and standards. For instance, verify whether the cable ampacity meets the requirements.
- The cable insulation layer may be aging, and even damaged in a high temperature environment. Therefore, at least 30 mm of distance shall be kept between the cables and heater or periphery of heat sources.
- Do as follows to prevent cables from brittle cracking due to shocking or shaking in the low temperature environment, and ensure operation safety:
 - a. Handle gently when installing cables in a low temperature environment above 0°C.
 - b. Must move the cables indoors and leave them for more than 24 hours before installing them, if the previous storage temperature is below 0°C.
- Do not throw cables to prevent damage and deteriorate performance, such as current capacity, temperature, etc.

NOTICE!

The static electricity generated by human beings can damage the static-sensitive components on the board, like large scale integrated circuit. Therefore, please follow the steps below to prevent static electricity:

- Operators must wear anti-static clothing, and anti-static gloves or wrist straps before contacting the boards, modules with exposed circuit boards, or application specific integrated circuits (ASIC). If the anti-static wrist strap is used, hook up the metal clip that's on one end to a grounded and unpainted metal surface.
- Hold the circuit board or the modules with exposed circuit board by its edges without components. Do not contact the components.
- Use anti-static materials to pack the removed boards or modules before storage or transportation.

2 Product Overview

2.1 Product Introduction

The product "TRENE-P100B215I", a smart outdoor energy storage system with easy installation and convenient expansion, integrates high-capacity battery packs, a high-performance inverter, smart EMS, high-voltage box, and fire extinguishing system in a cabinet based on the design concept of "ALL-IN-ONE". The industrial and commercial scenarios are designed to be broadly applicable.

2.1.1 Features

Cabinet Features

To maintain higher stability of battery cells, the cabinet integrates a smart air cooling system, a quadruple fire safety system, and an AC/DC lightning protection system II, with features of high-performance LFP battery cells, small foot space, high-energy density of a single cabinet, and capacity that can be expanded to the MWh level. Besides, the device also supports the following functions:

- Wireless meter;
- Smart control strategy based on photovoltaic and load conditions;
- Virtual Power Plants (VPPs) and microgrid;
- 24/7 remote maintenance and setting.

2.2 Cabinet Overview

2.2.1 Appearance and Dimension

Angle supports installed at front and rear sides

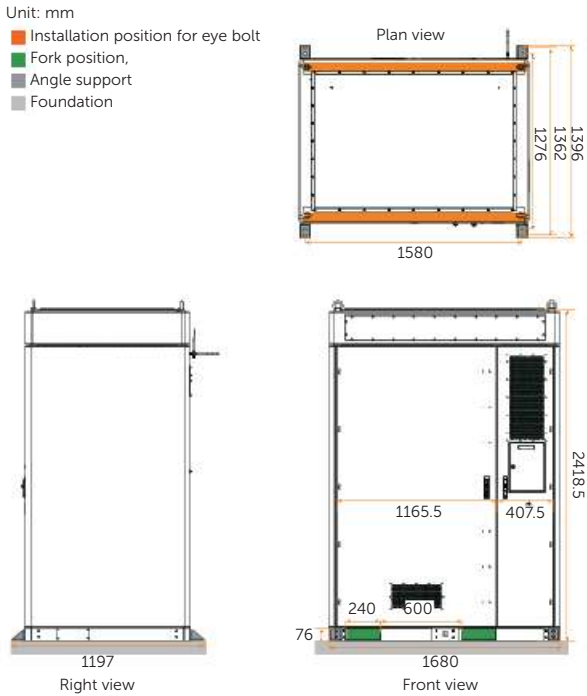

Figure 2-1 Appearance and dimension

Angle supports installed at left and right sides

Unit: mm

- Installation position for eye bolt
- Fork position,
- Angle support
- Foundation

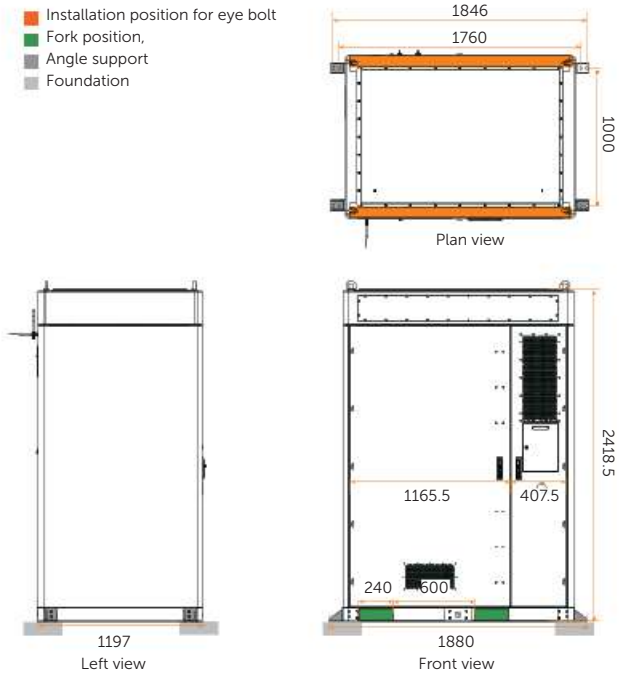

Figure 2-2 Appearance and dimension

2.2.2 Parts Description

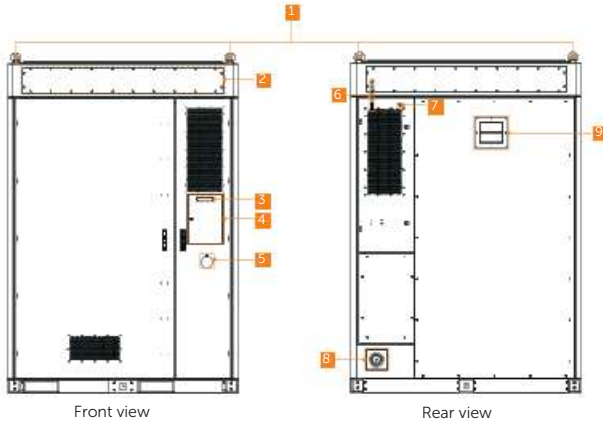

Figure 2-3 Parts description (in the closed state)

Table 2-1 Parts description

No.	Item	Description
1	Eye bolt	Material lifting applications.
2	Air conditioner	Energy storage system air conditioner.
3	LED light	To display status information of all processes running on the system.
4	Display screen	To display information of the whole system.
5	Emergency stop button	To shut down the system in emergency circumstances.
6	Antenna	A 4G antenna, to connect EMS.
7	A reserved antenna port	To connect wireless meter.
8	Fire hose nozzle	To connect the water supply sources.
9	Expansion-proof valve	To cool the escaping gases below the ignition temperature of the surrounding atmosphere.

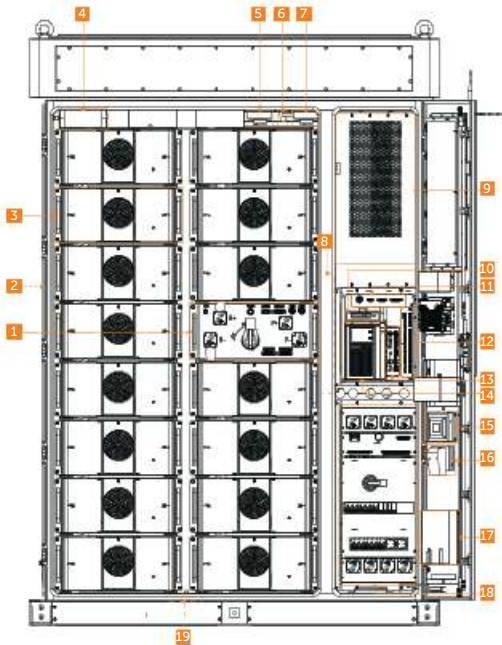

Figure 2-4 Parts description (in the opened state)

Table 2-2 Parts description

No.	Item	Description
1	High-voltage box	To collect current and voltage information on battery tower, and control the charge and discharge of battery pack.
2*	Temperature and humidity sensor	To measure temperature and humidity.
3	Battery pack	/
4	Automatic fire sprinkler	To control or suppress the spread of fire
5	Temperature sensor	To detect temperature.
6	CO detector	To detect CO gases.
7	Smoke detector	To detect smoke.
8*	Door sensor	To alert you when the door is open.
9	Inverter	/
10	HUB	/

No.	Item	Description
11	RS232 to RS485 Converter	/
12	IO module	To collect signal and control other modules.
13	EMS	A energy management system.
14	UPS	To provide backup power to ensure that the device is in a normal operating condition.
15	Control panel of air conditioner	To monitor the air conditioner and show relevant parameter.
16	Audible and visible alarm	To alert you when the abnormal conditions occur, such as temperature, smoke.
17	File pocket	To put documents.
18	Distribution box	To distribute AC power for the energy storage system.
19*	Water sensor	To detect water level based on the principle of potential difference between the two electrodes.

NOTICE!

- The mark "*" indicates that parts in the front view (Figure 2-4) cannot be fully seen.

The cabinet supports the installation of at least 7 battery packs (see Figure 2-5) and up to 15 battery packs (see Figure 2-6).

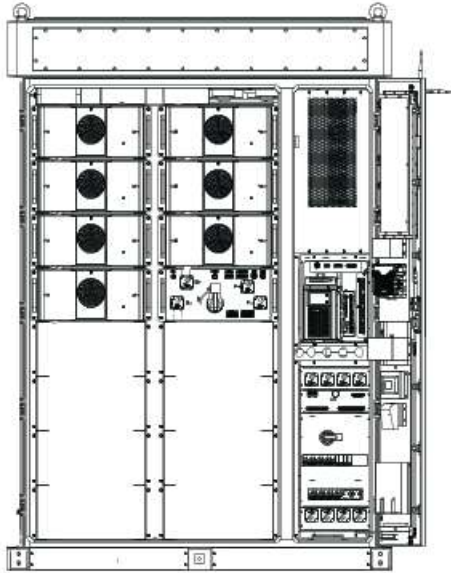

Figure 2-5 Seven battery packs

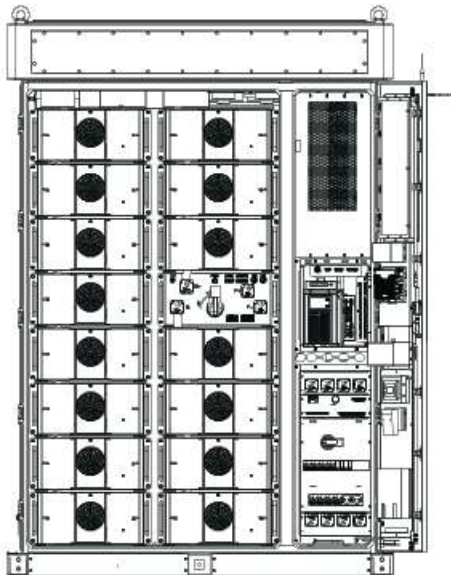

Figure 2-6 Fifteen battery packs

NOTICE!

- Given the wiring, it is suggested to install the high-voltage box at the position shown in the above figures.

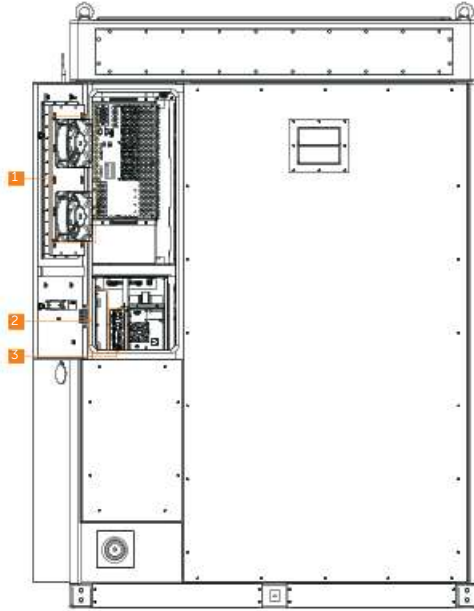

Figure 2-7 Parts description (in the opened state)

Table 2-3 Parts description

No.	Item	Description
1	Fan	To improve air circulation and dissipate heat when the temperature rises.
2	IO module	To collect signal and control other modules.
3	EMS	An energy management system.

2.3 High-voltage Box

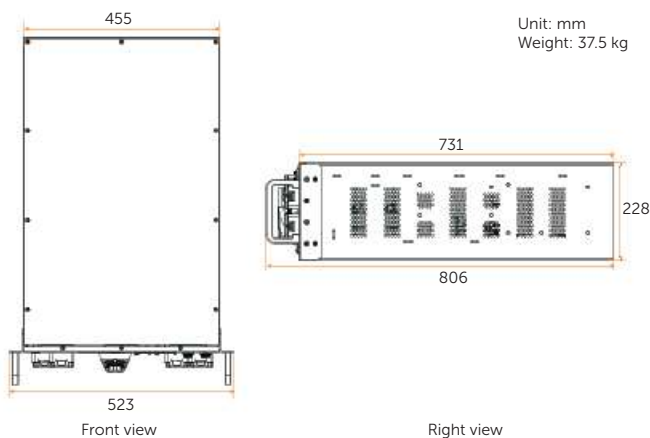

Figure 2-8 Dimension and weight

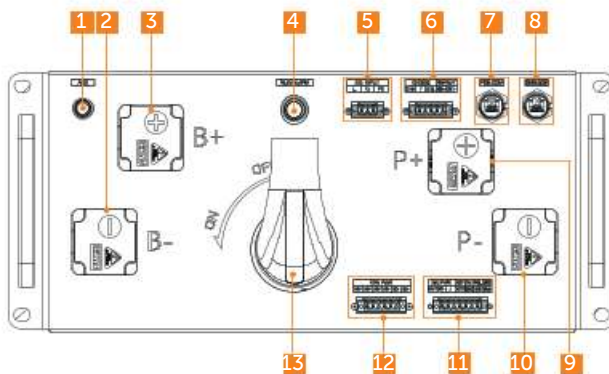

Figure 2-9 Front panel

Table 2-5 Description of front panel

No.	Item	Description
1	ADD button	To assign address.
2	Negative output port	To connect battery pack's negative terminal.
3	Positive output port	To connect battery pack's positive terminal.
4	Power button / status light	To start up or shut down system.
5	AC220V input terminal block	To connect distribution box's CZ1.

No.	Item	Description
6	Communication terminal block (for IO module)	To connect the IO module's CAN port and dry contact of the inverter.
8	Communication port (for inverter)	To connect inverter's communication port.
9	Communication port (for EMS)	To connect EMS's communication port.
10	P+ port	To connect inverter's positive terminal.
11	P- port	To connect inverter's negative terminal.
12	Terminal block (for battery pack)	To connect battery pack's communication cable and power cable.
13	Terminal block (for fan)	To connect fan's power cable.
14	Disconnect switch	To disconnect the device on the DC side.

2.4 Battery Pack

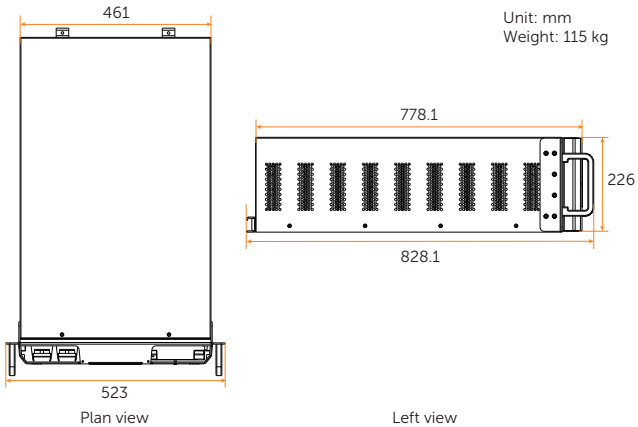

Figure 2-10 Dimension and weight

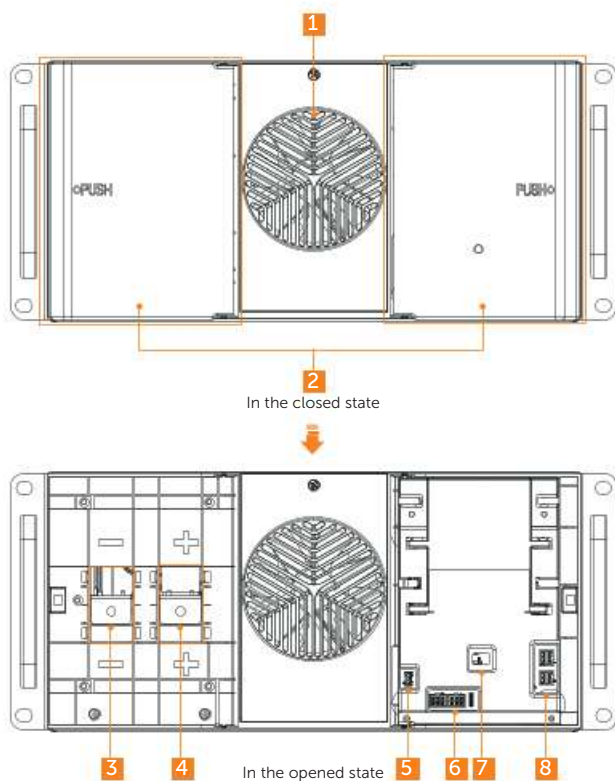

Figure 2-11 Front panel

Table 2-6 Description of front panel

No.	Item	Description
1	Fan	To keep components cool in the cabinet.
2	Left/right door	Please open the door while wiring.
3	Negative terminal	To connect negative terminal of high-voltage box or battery pack.
4	Positive terminal	To connect positive terminal of high-voltage box or battery pack.
5	Connection port (for fan)	To connect the fan.
6	Power connector (for fan)	To provide power to the fan.
7	BMS's status light	To display the running status of BMS.

No.	Item	Description
8	Communication port	To connect communication cable.

2.5 Distribution Box

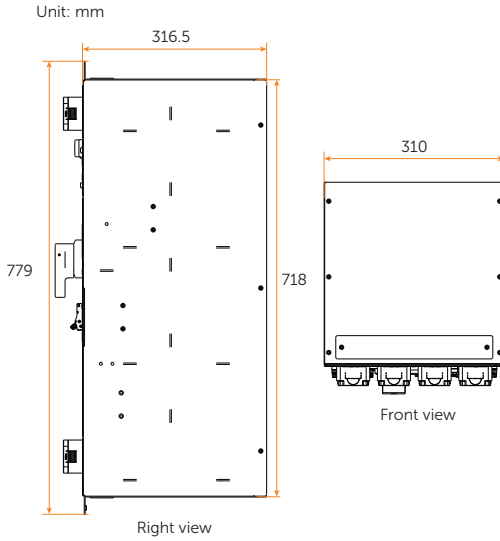

Figure 2-12 Dimension

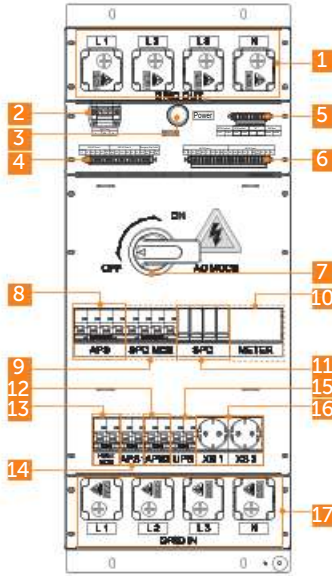

Figure 2-13 Front panel

Table 2-7 Description of front panel

No.	Item	Description
1	Grid out wire connector	For AC side
2	Power supply port for air conditioner	To connect to the air conditioner.
3	LED light	To display the operation state.
4	220 V power supply Port for controlling emergency stop switch	Provides 220V power for other devices in the cabinet. To manually turn off AC side for emergency.
5	Circuit breaker's electrical control signal	To remotely turn off AC power for emergency.
6	24V power supply port	To provide power supply for the devices inside the cabinet.
7	Disconnector	A switch for AC side.
8	APS	
9	SPD maintenance breaker	/
10	Meter breaker	
11	Current terminal	To connect to the grid.

No.	Item	Description
12	ASP2	
13	Air conditioner/liquid cooling unit on/off breaker	/
14	Auxiliary power breaker of High-voltage box	?
15	UPS breaker	To protect UPS breaker.
16	Socket	Power socket.
17	GRID IN wire connector	Port for connecting to power grid.

2.6 IO Module

Unit: mm

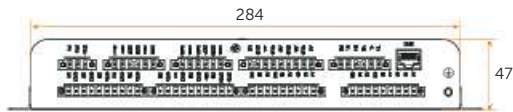
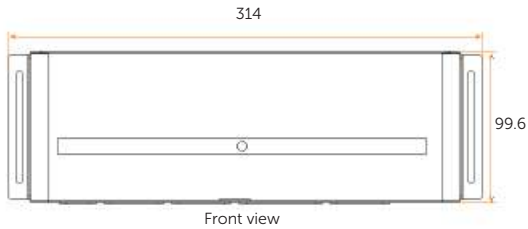

Figure 2-14 Dimension

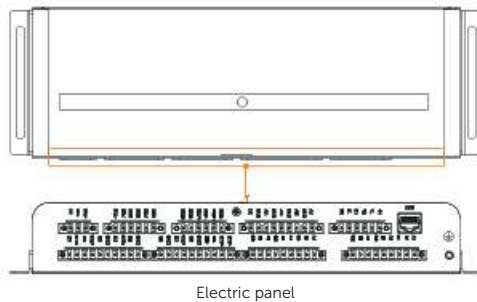

Figure 2-15 Electric panel

2.7 Other Parts

2.7.1 Air Conditioner

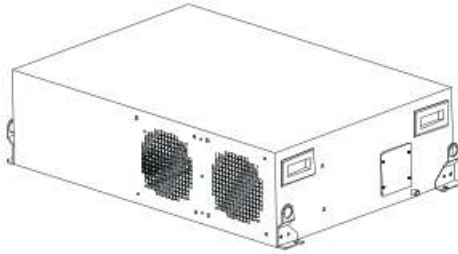

Figure 2-16 Appearance of air conditioner

NOTICE!

- Please refer to when [“Chapter 9.3.2 Disassembly and Clean of Air Conditioner Filter”](#) it's time to clean or replace the air conditioner filter.

2.7.2 Automatic Fire Sprinkler

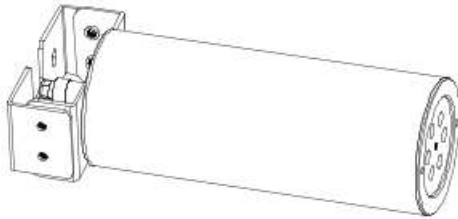

Figure 2-17 Appearance of automatic fire sprinkler

2.7.3 Temperature Sensor



Figure 2-18 Appearance of temperature sensor

2.7.4 Smoke Detector

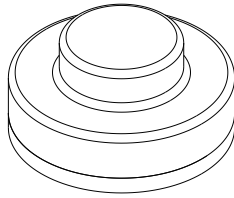

Figure 2-19 Appearance of smoke detector

2.7.5 CO Detector

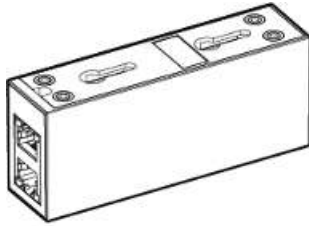

Figure 2-20 Appearance of CO detector

2.7.6 Temperature and Humidity Sensor

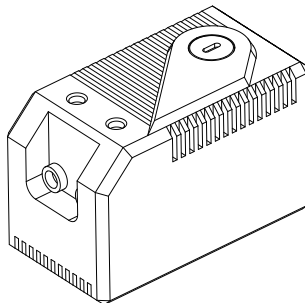

Figure 2-21 Appearance of temperature and humidity sensor

2.7.7 Audible and Visible Alarm

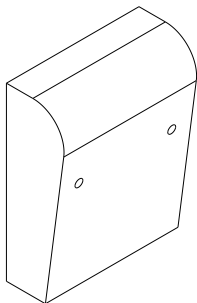

Figure 2-22 Appearance of audible and visible alarm

2.7.8 Water Sensor

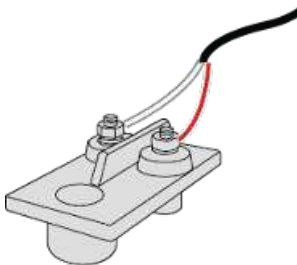

Figure 2-23 Appearance of water sensor

2.7.9 Door sensor

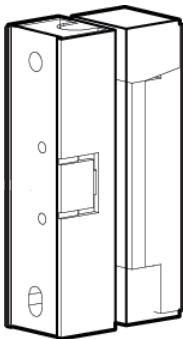

Figure 2-24 Appearance of door sensor

2.8 Operating Principle

2.8.1 Electrical Block Diagram

The label on Electrical Block Diagram should be pasted on the back door. For the position, see Figure 2-20.

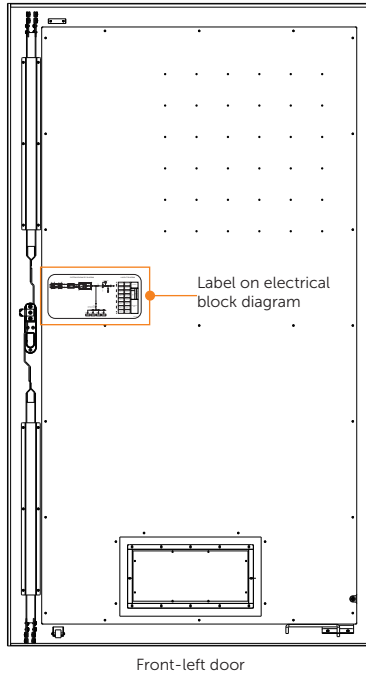

Figure 2-25 Label position

For the detailed information about the label, see Figure 2-21.

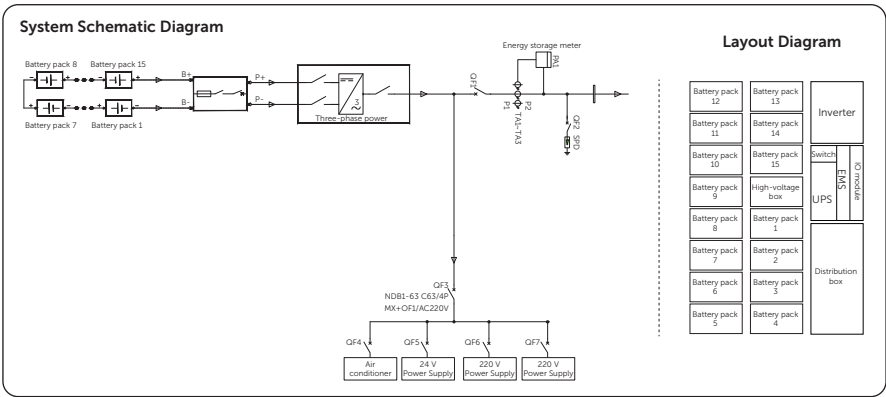

Figure 2-26 Electrical Block Diagram

NOTICE!

- In an off-grid situation, the current will vary due to the types of electrical loads. The common electrical load can be classified into following types, resistive load, inductive load, capacitive load, half-wave load, etc. Therefore, the types of electrical loads shall be fully considered when designing and configuring a system. In the case of a half-wave load, the load power shall not exceed 1 kW; in the case of an uncertain electrical load, please contact the supplier for evaluation of output supply to special loads.

2.8.2 Indicator

Cabinet's LED Light

The cabinet is equipped with a tri-colour indicator (green/yellow/red) to show its operating status.

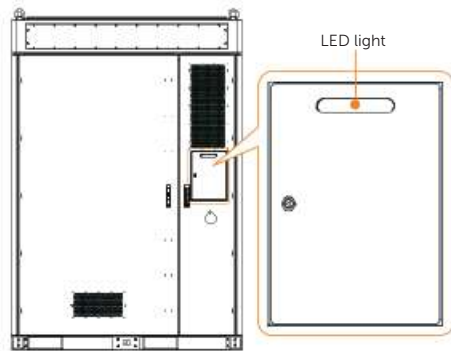

Figure 2-27 LED light

Table 2-8 Description

Status		Description
Solid yellow light		In standby
Solid green light		In operation
Solid red light		System failure

High-voltage Box's Indicator Light

The box is equipped with a bi-colour indicator (green/red) to show its operating status.

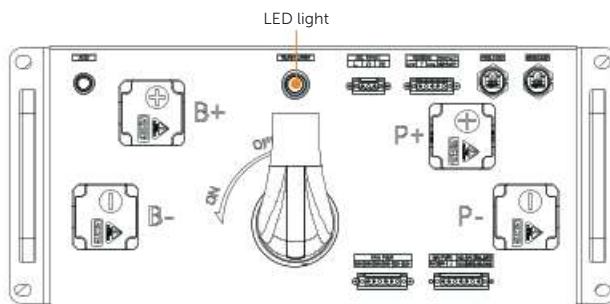





Figure 2-28 LED light

Table 2-9 Description

Status	Description
Flashing green light 	Press and hold "power button" ≥ 15 seconds to enter into "operating state". During this period, the system will assign each battery pack in a communication loop a unique address (battery number).
Solid green light 	In operation
Solid red light 	System failure

Battery Pack's LED light

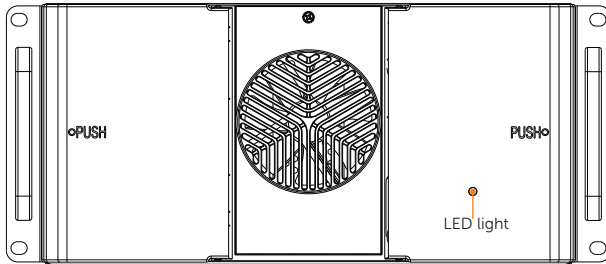







Figure 2-29 LED light











Table 2-10 Description

Status	Description
Flashing green light 	In operation

2.9 Symbols

Table 2-11 Symbol description

Symbol	Description
	CE mark of conformity.
	TUV certification.
	RCM mark of conformity
	Protective grounding point.
	Grounding point.
	Caution, hot surface. The enclosure temperature may be high while running. Therefore, do not contact to avoid scalding.

Symbol	Description
	Danger, electric shock. Do not touch the device after it is powered on. Otherwise, an electric shock may occur.
	Danger. Due to possible risks, do not touch the device after it is powered on.
	Observe enclosed documentation.
	The device cannot be disposed together with the household waste.
	Do not operate the inverter until it is isolated from mains and on-site PV generation suppliers.
	Danger of high voltage. Do not touch live parts for 15 minutes after disconnection from the power sources.
	The battery system must be disposed of at a proper facility for environmentally-safe recycling.
	The battery pack may explode. The rechargeable battery can become hot during operation. Avoid touch during operation.
	Keep the device away from children.
	Keep the device from open flames or ignition sources.

3 Transportation and Storage

3.1 Transportation Requirements

⚠ DANGER!

- Do not disassemble the battery violently. Otherwise, it may lead to battery pack short circuit, damage to the device (leakage, rupture), fire, or explosion.

⚠ WARNING!

- Hold the handles on the device or put your hands underneath the device to move or lift, and do not hold the handles on the parts installed in it.
- Strictly follow the document to carry or move the battery pack. Ensure that the device is correctly placed. Do not place a battery upside down or vertically, lay it on one side, or tilt it. And keep away from rain and water.

General requirements are shown as follows:

- Please pay attention to the signs on the package.
- To prevent injury from oversize loads, assess the device you're about to lift before you start lifting.

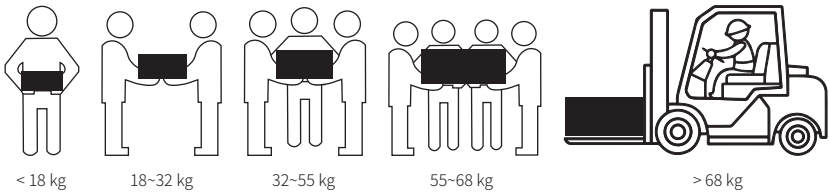

Figure 3-1 Lifting requirement

- If more than 2 people lift a device, reasonably arrange to have a balanced weight distribution
- Wear personal protective equipment, such as, safety gloves, safety boots, etc., to prevent needless injuries when lifting devices with bare hands.
- Know the right body posture to prevent personal injuries when lifting devices, for instance, bend at your knees, not at your waist or back, and do not twist your back.
- Hold the handles on the device or put your hands underneath the device to move or lift, and do not hold the handles on the parts installed in it.

- To prevent injuries, do not quickly lift the heavy device above the waist.
- To prevent scratches and dents, or damage to components and cables, avoid impact and falling when moving.
- Be aware of workbenches, slopes, steps, and other places where it is easy to slip when moving devices. Ensure that the passageways are smooth, clean, and away from obstacles.
- To prevent tipover, the forklift's forks must be placed under the load. Center the weight of the load between the forks, and adjust the forks to distribute the weight evenly. Firmly attach the loads to the forks before lifting, and arrange for people to watch for when lifting.
- Sea and road (in good condition) transports are an idea for the device instead of rail and air transports. Transport staff should do their best to avoid bumpiness and inclination as much as possible.
- The tilt angle of the cabinet must meet the requirement as shown in Figure 3-2. The angle before unpacking: $\alpha \leq 15^\circ$; the angle after unpacking: $\alpha \leq 15^\circ$.

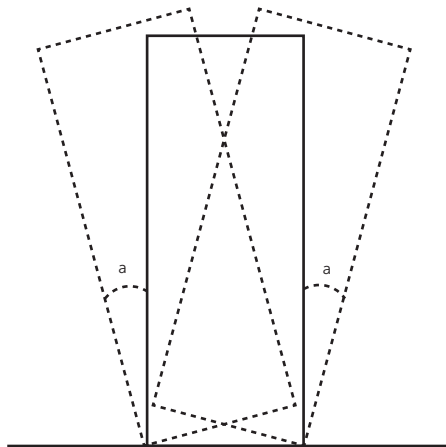

Figure 3-2 Tilt angle

- The battery pack has been certified according to UN38.3: *Section 38.3 of the Sixth Revised Edition of the Recommendations on the Transport of Dangerous Goods: Manual of Tests and Criteria* and SN/T 0370.2-2009 *Rules for the Inspection of Packaging for Export Dangerous--Part 2: Performance Test*. Therefore, the battery pack is classified in Class 9.
- Relevant qualifications for transport of dangerous goods must be obtained by the forwarding agent engaged in such businesses. Do not transport it in an open trailer.
- Strictly abide by the international regulations on the transport of dangerous goods, and meet the supervision requirements stipulated by the transport

authority of the departure country, transit country, and country of destination, respectively.

- Before transportation, check that the battery package is intact and that there is no abnormal odor, leakage, smoke, or sign of burning. Otherwise, the batteries cannot be transported.
- The packing case must be secured for transportation. Handle the case with care during loading, unloading, and transportation, and take measures to prevent moisture damage to the device during transportation.
- Handle gently when moving the battery pack to prevent bumping and damage to individuals.
- Unless otherwise specified, dangerous goods shall not be mixed with goods containing food, medicine, animal feed, or their additives in the same vehicle or container.
- Unless otherwise specified, do not transport dangerous goods together with food, medicine, animal feeds, or other additives on the same means of transport (e.g., vehicle, container).
- Before moving a faulty battery pack (with scorch, leakage, bulge, or water intrusion), insulate its positive and negative terminals, pack it, and place it in an insulated explosion-proof box as soon as possible. Record information such as the site name, address, time, and fault symptom on the box.
- Keep away from flammable material storage areas, residential areas, and other population centers (e.g., public transport, elevators) when transporting the faulty battery pack.

3.2 Storage Requirements

3.2.1 Cabinet Storage

- Do not remove the original packaging material and check the outer packaging material regularly.
- The required storage temperature: $-30^{\circ}\text{C} \sim 55^{\circ}\text{C}$.
- The relative humidity should be between 5% and 95%.
- Store the device according to the caution signs on the packaging to prevent equipment damage.

3.2.2 Battery Pack Storage

 **DANGER!**

- Ensure that batteries are stored in a dry, clean, and ventilated indoor environment that is free from sources of strong infrared or other radiations, organic solvents, corrosive gases, and conductive metal dust. Do not expose batteries to direct sunlight or rain and keep them far away from sources of heat and ignition.
- If a battery is faulty (with scorch, leakage, bulge, or water intrusion), move it to a dangerous goods warehouse for separate storage. And it must be scrapped as soon as possible.
- Store the device according to the caution signs on the packaging to prevent equipment damage. Do not place a battery upside down or vertically, lay it on one side, or tilt it.
- Store the battery packs in a separate place. Do not store them together with other devices. Do not stack too high. The storage site should be equipped with qualified fire fighting facilities, such as fire sand and fire extinguishers.

NOTICE!

- If a battery pack is stored for a long time, please periodically recharge it to protect from damage. For details, please refer to "[Chapter 9.3.2 Maintenance of Battery Pack](#)".
- The required storage temperature, see the following table 3-1.

Table 3-1 Storage temperature and time

Storage Temperature	Storage Time
50°C to 60°C	3 months
30°C to 50°C	6 months
-20°C to 30°C	12 months

- The relative humidity should be between 5% and 95%.
- If the rechargeable battery has been stored for more than 1 year, it must be checked and tested by professionals before use.

4 Preparation before Installation

4.1 Installation Site Selection

Given the importance of the installation site to the security, service life and performance of the equipment, the site should be selected according to NFPA 855 *Standard for the Installation of Stationary Energy Storage Systems* and local regulations, and based on the principles of wiring, operation and maintenance for convenience.

NOTICE!

- During the installation, commissioning, and operation, fire extinguishers shall be equipped nearby the device according to the fire requirements. The number of fire extinguishers shall be over 2.
- The minimum distance between air exhaust of the equipment and buildings or other equipment's heating ports, ventilation opening, air conditioner vent, windows, doors, or hot sources shall be 4.6 m.
- A port for water fire extinguishing system shall be reserved.
- Measures, for instance, setting up water baffles or drainage facilities, or raising the ground, shall be taken in an unavoidable situation, like an installation site where rainwater may accumulate.

The installation site shall meet the following requirements:

- The device is intended only for outdoor use.
- The surface level of the site must be at least 300 mm above the highest water level in the area. Do not install the equipment in a low-lying area.
- Ensure that no plants have been grown within 3 meters of the site and its surroundings, to avoid wildfires due to the high temperature in the summer which results in equipment on fire.
- Given safety reasons, the distance between the equipment and residential housing shall be over 12, as well as at least a distance of 30.5 meters between the equipment and schools, hospitals, or other population centers. Otherwise, a fire wall must be constructed between the equipment and buildings.
- The safe distance between the equipment and industrial buildings shall meet the local fire safety codes and standards.

Table 4-1 Safe distance

	Safe Distance
The safe distance between the equipment and Class A industrial buildings	≥ 12 m

	Safe Distance
The safe distance between the equipment and Class B industrial buildings	≥ 10 m
The safe distance between the equipment and Class C and D industrial buildings which meet the requirements of Class I and II fire resistance rating	≥ 10 m
The safe distance between the equipment and industrial buildings which meet the requirements of Class III fire resistance rating	≥ 12 m
If the external wall of the adjacent building with fire-resistant materials, and without windows, doors, and extended eaves, the safe distance shall	$(3 - 25\% * 3)$ m

- If the above-mentioned safe distance cannot be met, a fire wall between the equipment room, storage room, or installation area and Class C, D and E buildings shall have a 3-hour fire-resistance rating. The height and thickness of the fire wall shall be 1 meter over the equipment. In addition, the factors, such as transportation, installation, and maintenance, should be considered before construction.
- Keep away from flammable and combustible.
- Convenient transportation and reliable fire suppression systems are required to be equipped at the installation site.
- Please reserve enough space for capacity expansion.
- The site shall be well ventilated.
- Since the salt-damaged and polluted areas may corrode the equipment, do not install this equipment in those areas. Please strictly follow the requirements below when installing the equipment.
 - » If the installation site of the equipment is selected at the coast, the distance from the equipment to the shore should be over 2000 m. In case the distance from the equipment to the shore is between 500 m and 2000 m, it is not recommended to install (if the user wants to install here, do not install until gets to an actual approval from the distributor or our company's engineer). Additionally, do not install the equipment if the distance from it to the shore is less than 500 m.
 - » The distance from the equipment to the smelters, coal mines, thermal power plants, and other heavy pollution sources should be between 1500 m and 3000 m.
 - » The distance from the equipment to the chemical plants, rubber plants, electroplate factory, and other moderately polluted sources should be between 1000 m and 2000 m.
 - » The distance from the equipment to the light pollution sources, such as food processing plants, leather processing plants, heating boiler factory, slaughter

houses, dumping sites, and sewage treatment stations, should be between 500 m and 1000 m.

Table 4-2 Installation spacing requirements

	Safe Distance
Distance from coastal areas	> 2000 m
Distance from heavy pollution sources, such as smelters, coal mines, thermal power plants	1500 m ~ 3000 m
Distance from moderate pollution sources, such as chemical plants, rubber plants, and electroplate factory	1000 m ~ 2000 m
Distance from light pollution sources, such as food processing plants, leather processing plants, heating boiler factory, slaughter houses, dumping sites, and sewage treatment stations	500 m ~ 1000 m

- Keep away from the sand and dust environment.
- Keep away from areas with high vibration, strong noise sources, or strong electromagnetic interference.
- Keep away from places that are easily to generate dust, oil fumes, harmful gases, corrosive gases, etc.
- Keep away from places that store corrosive, flammable and explosive materials.
- Keep away from places where underground facilities have been built.
- Keep away from areas at poor geological conditions (such as rubber soil, weak soil), as well as the waterlogged ground or land subsidence.
- Keep away from places below water reservoirs, water landscapes, and water intake rooms.
- Keep away from seismic zone and earthquake areas of which a seismic fortification intensity is over 9 degrees.
- Keep away from areas where natural disasters (such as debris flow, landslide, quicksand) are likely occur, as well as karst caves.
- Do not install the equipment within the boundaries of mining subsidence (impact) areas.
- Keep away from an area where there is a risk of explosion.
- Keep away from areas that are likely to be flooded if levees or dams broke.
- Keep away from important water source protection areas.
- Keep away from heritage protected areas.
- Keep away from population centers, high-rise buildings, and underground

structures.

- Keep away from intersections of urban main roads and heavily travelled roads.
- Please strictly select the installation site in accordance with the following requirements for flood prevention and rainwater control:
 - » The height of the foundation for the large, medium and small electrochemical energy storage systems must be over the highest water level in history.
 - » If the installation site cannot meet the above-mentioned requirements, please find another site, or take measures to prevent flooding and waterlogging based on the actual situation.
 - » Regarding the energy storage power stations affected by wind and wind-waves from rivers, lakes, and seas, the height of the foundation must be 0.5 m above the highest wave height in history.
 - » If a large amount of water flows in or through the foundation, a side ditch or drainage channel is recommended to be built.
- The installation site needs to be equipped with a "Stop" sign:
 - » Solid walls or fences around the energy storage equipment area are recommended to be built. In the case of fences, they have to be lockable, with a height of over 2.2 m. The firewall can be built in place of part or the entire fence based on comprehensive considerations.

4.1.1 Installation Environment Requirements

Installation environment shall meet the following requirements:

- Temperature: $-30^{\circ}\text{C} \sim +50^{\circ}\text{C}$
- Relative humidity: $0 \sim 95\% \text{ RH}$
- Altitude: Below 3000 meters.
- Good ventilation.
- Keep away from flammable, explosive, and corrosive substances, and antennas.

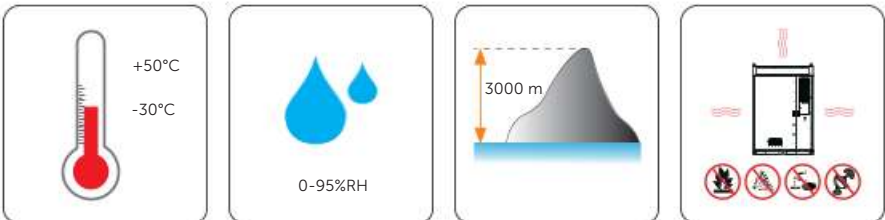

4.1.2 Installation Foundation Requirements

The requirements for foundation are shown as follows:

- The foundation must be made of non-combustible materials, such as solid bricks or concrete. And ensure that the foundation is level, smooth and firm, and has sufficient bearing capacity to withstand the load from the equipment.
- The bearing capacity of the foundation shall be over 5 t. If the above-mentioned requirement cannot be met, re-inspection is required.

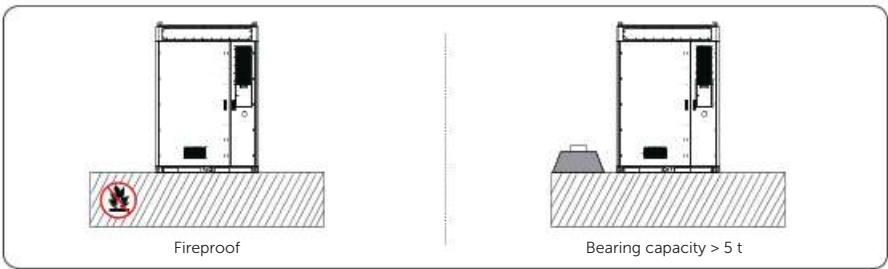

Figure 4-3 Foundation requirement

- The bottom of the foundation pit must be strengthened and filled.
- Do not water or disturb the foundation after starting to dig it. If the foundation is watered or disturbed, continue to dig down and remove the bad soil, and then refill with quality materials.
- The angle of depression between the foundation and cabinet shall be less than 5°, as well as the height of less than 3 mm.
- The foundation is not only higher than the local high-water mark, but also at least 300 mm above the ground.
- Construct drainage facilities based on local geological conditions and municipal drainage standards to ensure that there is no water accumulation at the foundation. The foundation construction should meet the drainage requirements for maximum volume of rainfall in the locality, and the discharged water needs to be treated in accordance with local laws and regulations.
- Dig a trench or reserve a cable entry hole by considering the electrical wiring of the equipment before construction of the foundation.
- Both the reserved holes on the foundation and the cable entry holes on the equipment should be sealed.
- The foundation drawing is only for reference, and cannot be regarded as the final construction drawing. Operators shall recheck the basic parameters according to the environment, geological conditions, seismic requirements, etc. of the installation site.
 - » Angle supports installed at front and rear sides;
 - » Angle supports installed at left and right sides.

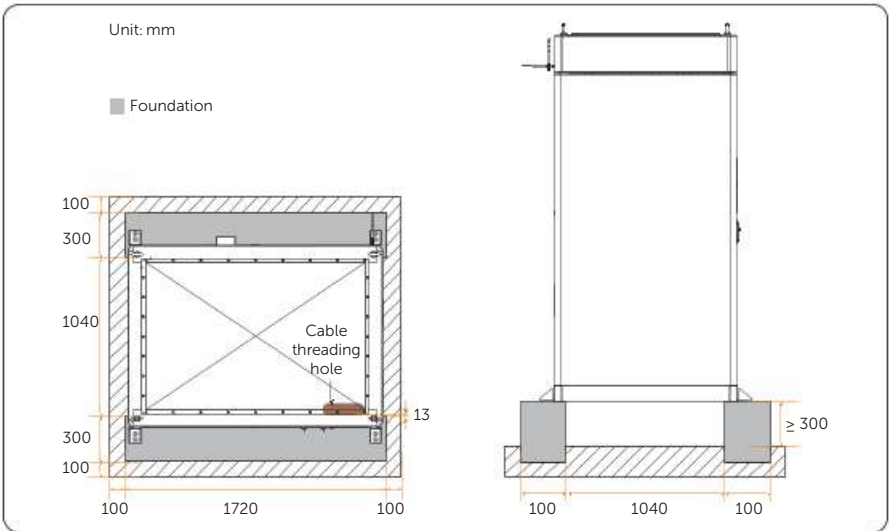

Figure 4-4 Foundation parameter requirements for angle supports installed at front and rear sides

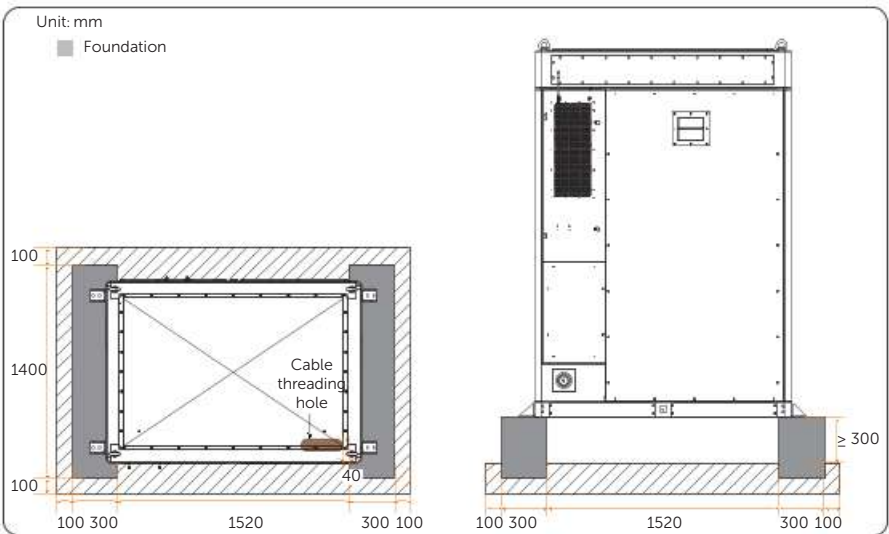

Figure 4-5 Foundation parameter requirements for angle supports installed at left and right sides

4.1.3 Forklift Requirements

- Before using the forklift, ensure that it meets the load requirements: load capacity ≥ 5 t;
- The recommended forklift should meet the following requirements: length of fork blade > 1.2 m, width of fork blade between 80 cm and 160 cm, and thickness of fork shank between 25 cm and 70 cm;

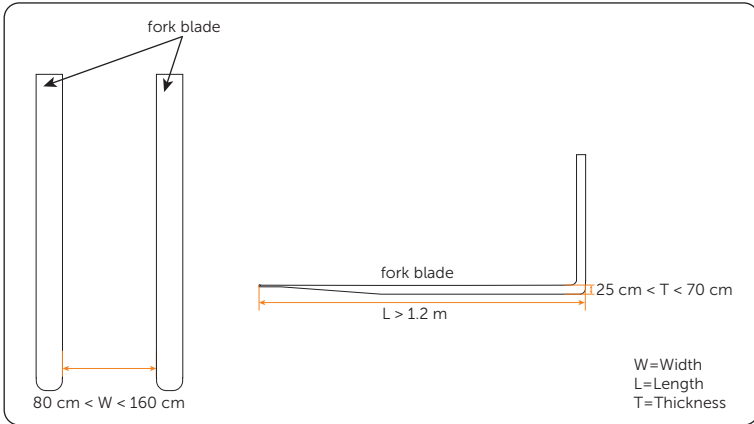

Figure 4-6 Requirements for forklift

4.1.4 Hoisting Requirements

- Ensure that the crane and steel wire rope meet the load-bearing requirements.
- To prevent the cabinet from scratching, do not drag it when installing and removing hoisting equipment.

Table 4-3 Precaution

	Precaution
Before hoisting	The crane's lifting capacity shall equal or exceed 5 t, as well as the working radius of equaling or exceeding 2 m. If the above requirements cannot be met, it is required to be evaluated by professional personnel.
	A trained and qualified lifting personnel is required.
	Check to ensure that the hoisting tools are in good condition and complete.
	Ensure that the hoisting tools are fixed securely to the fixture or wall that meets the load-bearing requirements.
	Do not operate a hoist if severe weather or wind is apparent when conducting hoisting outdoors.
	Ensure that the crane and steel wire ropes meet the requirements.
	Ensure that all the doors of the equipment are closed and locked.
	Ensure that the knots among steel wire ropes are securely fastened.
During hoisting	To ensure that the lifting can proceed successfully, it is suggested to conduct it according to the order from left to right or right to left.
	Keep unauthorized people from entering the area and standing under crane boom.
	Ensure that the crane is parked in place and avoid long-distance lifting.
	Keep stability, and dutch angle of the cabinet should be less than or equal 5°.
	Ensure that the angle between the two steel wire ropes is less than or equal 90°.
	To avoid impacting the internal components of the equipment, the lifting equipment should be lifted and lowered gently, as well as the cabinet.
	Do not dismantle the steel wire ropes until the cabinet lands smoothly, when it contacts the foundation.
	Do not drag steel wire ropes and lifting tools, and crash the equipment.
Do not dismantle the steel wire ropes to hoist the next cabinet until the cabinet lands smoothly.	

4.1.5 Clearance Requirement

This equipment has multiple installation methods:

- Single cabinet
- Multiple cabinets: 1. Install separately; 2. Install multiple devices together.

In order to ensure the heat dissipation of the inverter and facilitate disassembly, the minimum space to be reserved around the cabinet must meet the following standards.

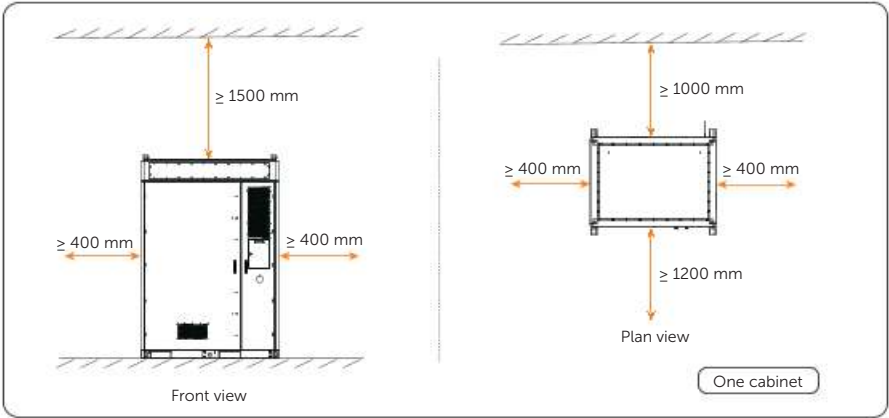

Figure 4-7 Single cabinet

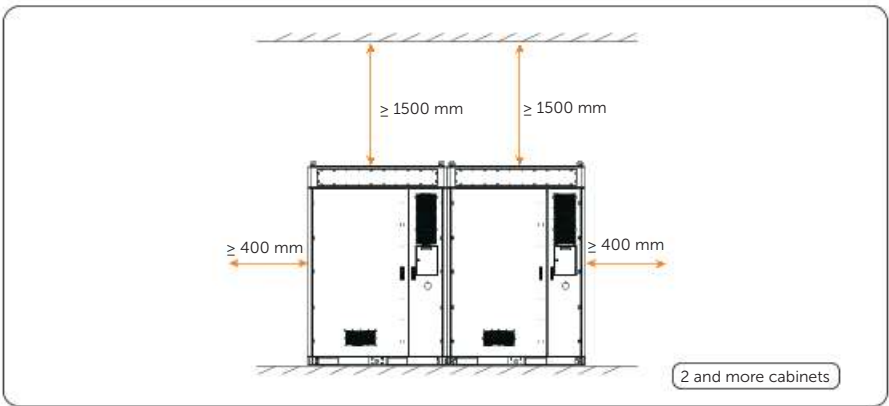

Figure 4-8 2 and more cabinets

4.2 Tools Requirement

The tools used include but are not limited to the recommended tools below. Please use other auxiliary tools according to the site requirements. Please note that the tools used must comply with local regulations.

 Hammer drill (Ø16 mm)	 Multimeter (Range: 1500 V)	 Measuring tape	 Utility knife
 Marker	 Cross screwdriver	 Flat-head screwdriver	 Wire cutter
 Wire stripper	 Crimping tool for RJ45	 Hydraulic wire crimper	 Rubber mallet
 Torque wrench (M4~M12)	 Torque screwdriver (Flat-head: M3) (Phillips head: M5)	 Heat gun	 Heat shrink tubing (Ø30~60 mm)
 Diagonal pliers	 Vacuum cleaner	 Cable tie	 Insulated ladder
 Crane	 Steel wire rope	 Electric forklift	 Steel pipe Ø25~30 mm

Preparation before Installation

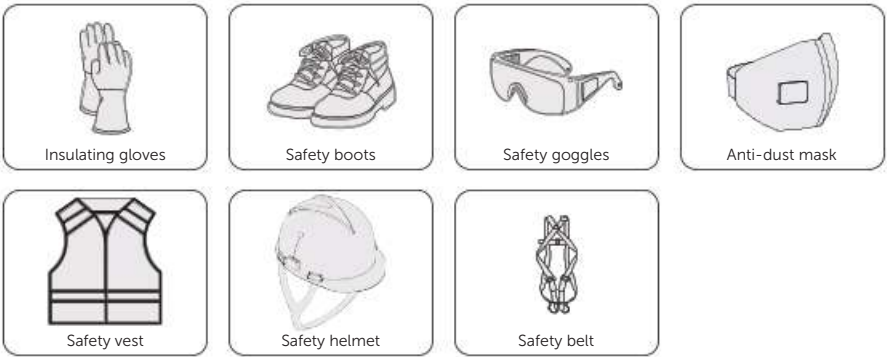

4.3 Additionally Required Materials

The following is a recommended list of equipment required for installation of the system.

Table 4-4 Additionally required wires

No.	Required Material	Type	Conductor Cross-section	
1	Grounding plate		Galvanized iron plate	Width: 40 mm Depth: 4mm
2	Grid wire		Five-core copper cable * The conductor cross-section of copper cables connecting to the distribution box (a total of 4 copper cables) is 50 mm ² , as well as 25 mm ² for a copper cable that is connected to the grounding.	50 mm ² * 4 + 25 mm ² * 1

5 Unpacking and Inspection

5.1 Unpacking

- The equipment undergoes 100% testing and inspection before shipping from the manufacturing facility. However, transport damage may still occur. Before unpacking the rechargeable battery, please verify that the model and outer packing materials for damage, such as holes and cracks.
- Due to the cabinet height exceeding 2m, please take necessary precautions for working at heights when removing the outer packaging. The unpacking procedure can be referred to the following Figure.

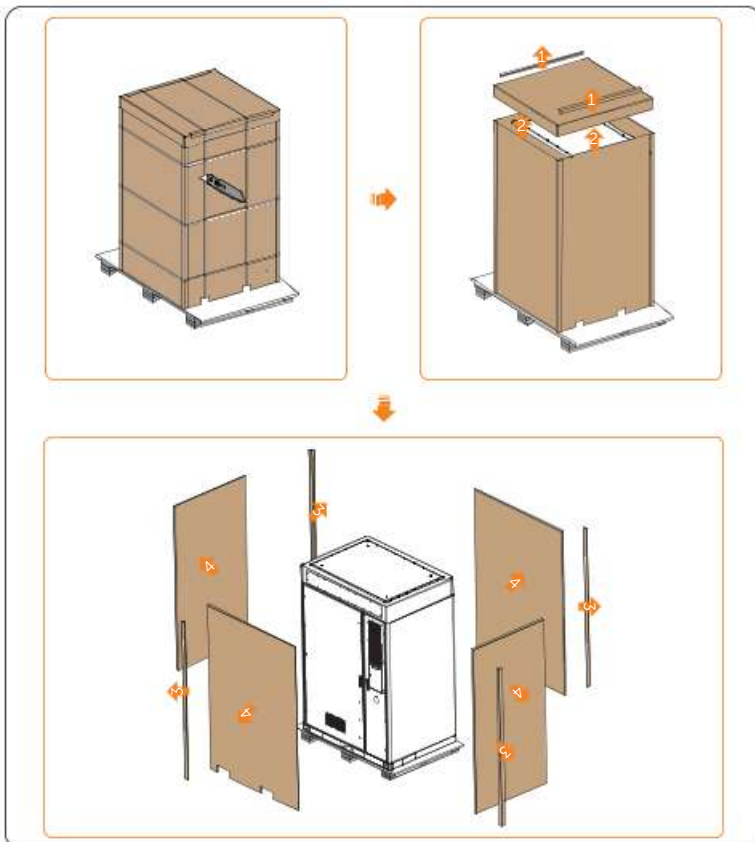

Figure 5-9 Unpacking

- When unpacking, please handle all packaging materials properly for future storage or relocation of this equipment.
- After unpacking, please check if the equipment is intact and if all accessories are complete. If there is any damage or missing accessories, please contact your dealer immediately for assistance.

5.2 Packing List

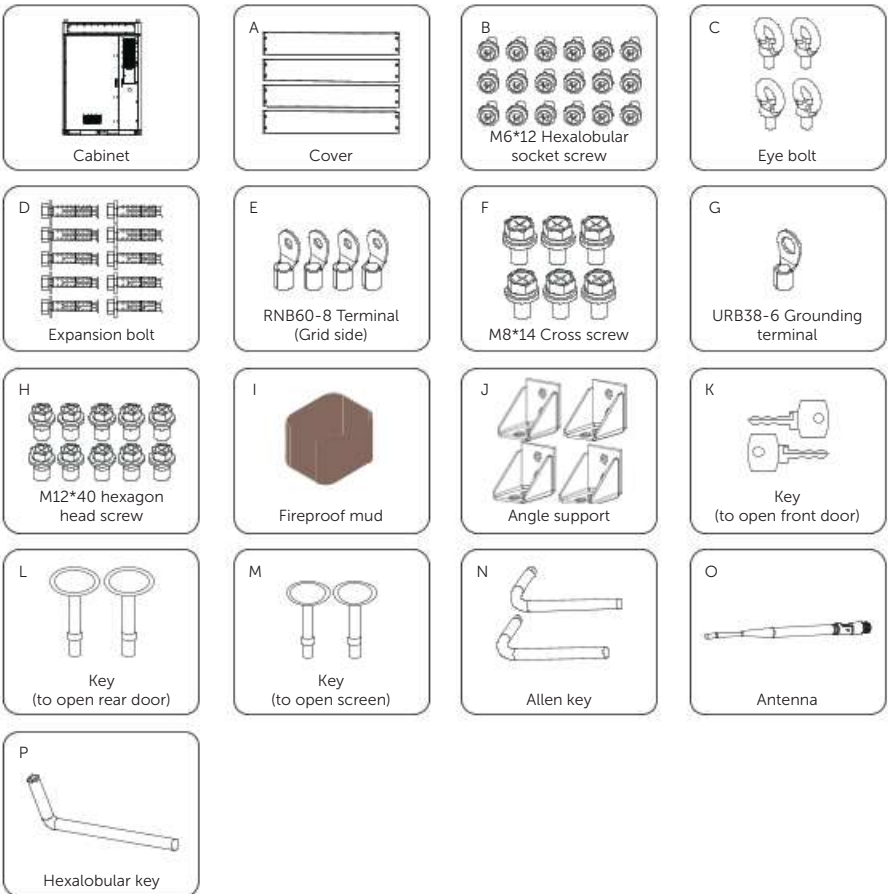

Table 5-1 Packing list

Item No.	Items	Quantity
/	Cabinet	1 pc
A	Cover	4 pcs
B	M4*10 Cross screw	18 pcs
C	Eye bolt	4 pcs
D	Expansion bolt	10 pcs
E	RNB60-8 Terminal (Grid side)	4 pcs
F	M8*14 Cross screw	6 pcs
G	URB38-6 Grounding terminal	1 pc
H	M12*40 hexagon head screw	10 pcs
I	Fireproof mud	2 kg
J	Angle support	4 pcs
K	Key (to open the front doors)	2 pcs
L	Key (to open rear door)	2 pcs
M	Key (to open screen)	2 pcs
N	Allen key	2 pcs
O	Antenna	1 pc
P	Hexalobular key	1 pc

6 Mechanical Installation

After determining the installation site, please take out the underground electrical wiring which is buried beneath the ground.

WARNING!

- This equipment must be installed by professionals in accordance with local regulations and standards.
- Before drilling, please check and avoid wiring inside the wall to prevent accidents.
- Use insulated tools and wear personal protective equipment (PPE) during installation and maintenance.

CAUTION!

- Pay attention to the weight of the equipment at all times during transportation and installation, as improper lifting or dropping of the equipment may cause personal injury.

6.1 Installation of Eye Bolt (Optional)

If the eye bolts are required to be installed based on the actual situation, please strictly follow the steps below.

- Step 1:** Remove the M20 screws (with a total of 4 pieces) inside the top eye bolt holes using a torque wrench.

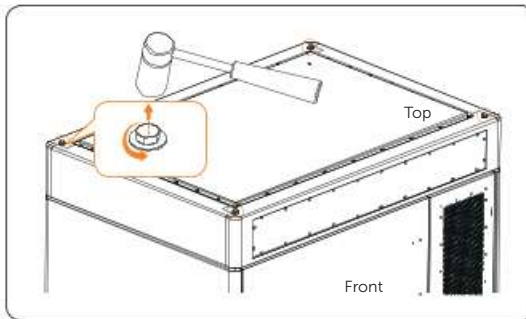

Figure 6-1 Unscrewing M20 screws

Step 2: Insert and clockwise the eye bolts (M20) (with a total of 4 pieces).

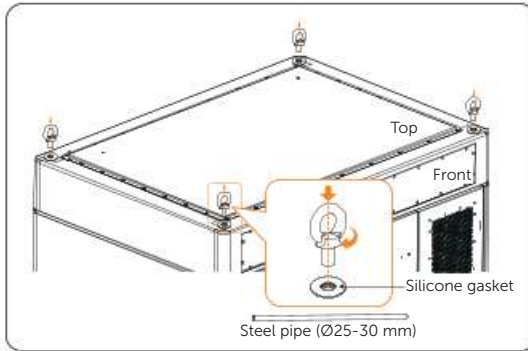

Figure 6-2 Tightening eye bolts

NOTICE!

- Put the silicone gaskets in place before inserting the eye bolts.

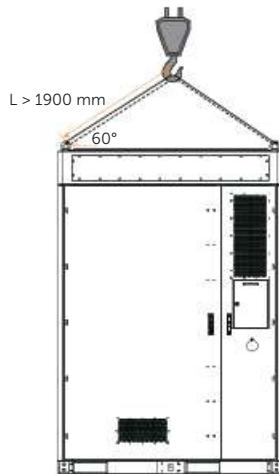

Figure 6-3 Lifting

NOTICE!

- L=Length

6.2 Fork Position

NOTICE!

- When using a forklift to move the cabinet, please secure it according to the actual situation to ensure that the cabinet does not pose a risk of tipping over.

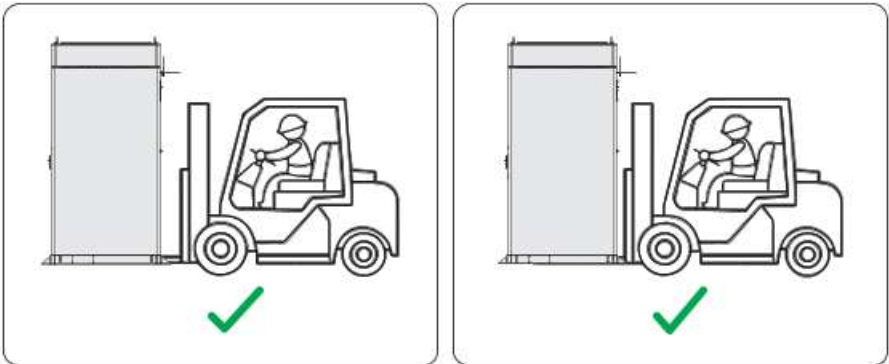

Figure 6-4 Right positions

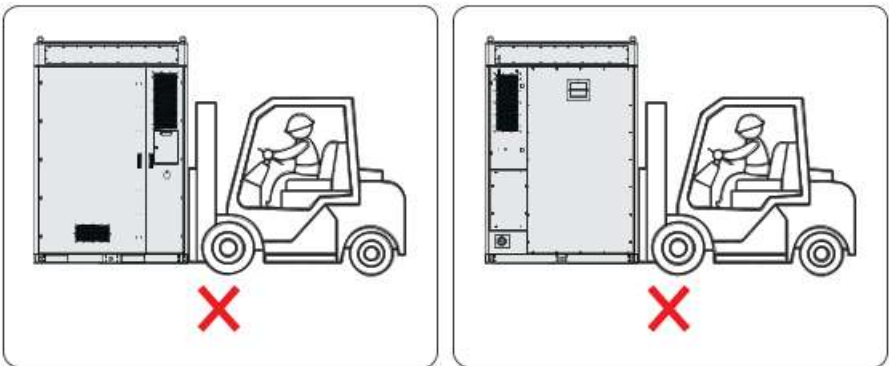

Figure 6-5 Wrong positions

NOTICE!

- For installation space requirements, please refer to "[Chapter 4.1.5 Clearance Requirement](#)".
- For foundation requirements, please refer to "[Chapter 4.1.2 Installation Foundation Requirements](#)".

6.3 Antenna Installation

NOTICE!

- The user can decide whether the reserved port connects an antenna based on the actual situation.
- Regarding the other antenna port (the right one), the antenna is delivered with the accessories kit.

There are two antenna ports in the cabinet. The left one is required to be installed an antenna, and the right one is a reserved port. For the antenna installation steps, please do as follows.

Step 1: Remove the silicone cap.

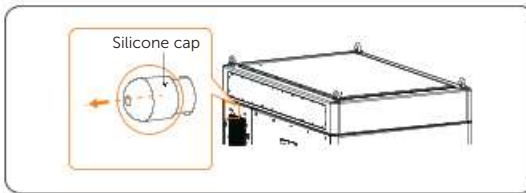

Figure 6-6 Removing silicone cap

Step 2: Fold the antenna up 90°.

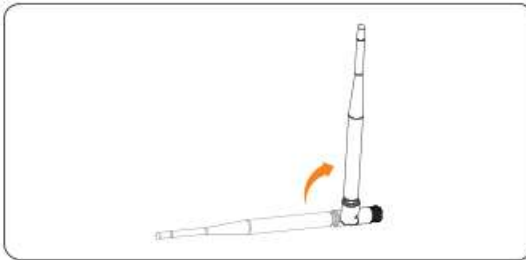

Figure 6-7 Folding the antenna.

Step 3: Take out the antenna, and make sure that it is securely inserted and tightened by turning it clockwise.

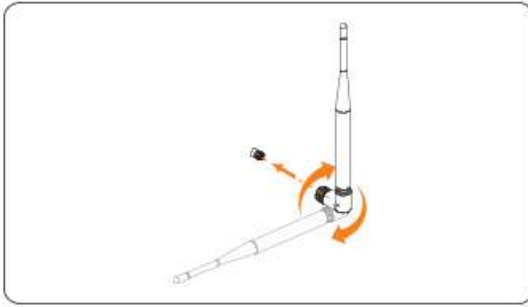

Figure 6-8 Installing antenna

After installing the antenna, see Figure 6-9.

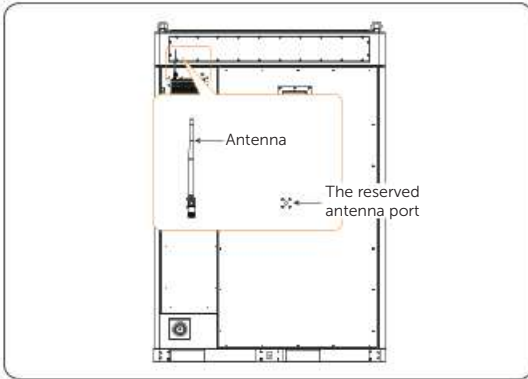

Figure 6-9 Installing an antenna

6.4 Installation Dimensions

Before installation, please refer to "[Chapter 2.2.1 Appearance and Dimension](#)" for installation, ensuring sufficient space is reserved for the installation and heat dissipation of the entire equipment.

6.5 Installation Procedure for Angle Support and Cover

The cabinet allows the angle supports to be installed at the front and-rear sides or at the left and-right sides. Since the installation procedure for the angle support is the same, the following steps take the angle support installed at the front and-rear sides as an example.

Step 1: After determining the installation position of the cabinet, align the holes on the angle support with the holes on the cabinet, and draw a circle on the bottom of the angle support. There are totalling 4 angle supports for a cabinet.

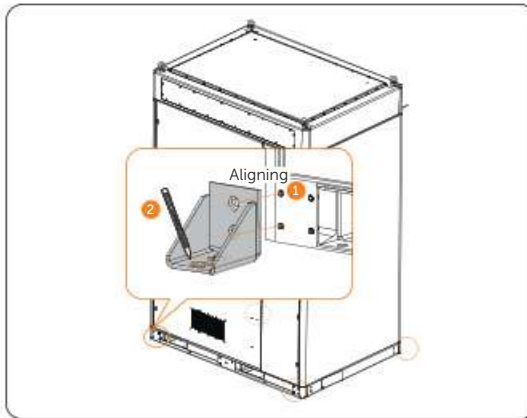

Figure 6-10 Marking hole position

Step 2: Drill holes at the previously marked positions (drill bit: $\text{\O}16\text{ mm}$; hole depth: 95~105 mm). After drilling, clean the foundation surface with a vacuum cleaner.

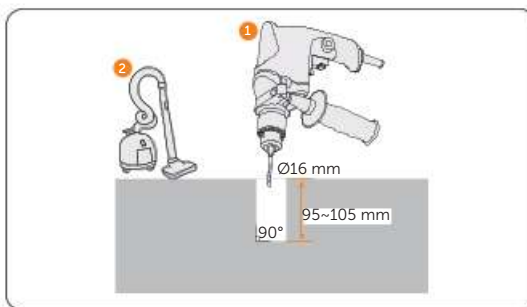

Figure 6-11 Drilling

Step 3: Attach the angle supports to the cabinet, and insert M12 screws and tighten them clockwise using a torque wrench (torque: 42 ± 4.2 N·m). Each angle support has two screws, with a total of four angle supports.

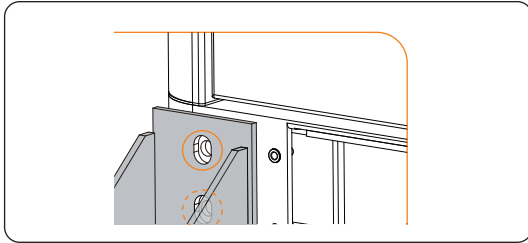

Figure 6-12 Aligning screw holes

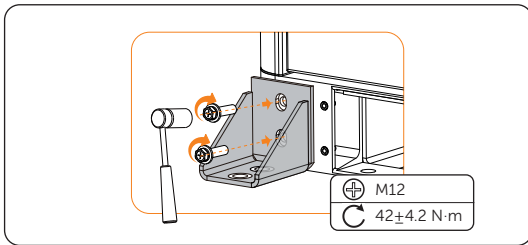

Figure 6-13 Tightening M12 screws

NOTICE!

- Reinstall the angle supports, ensuring that the screw holes on the angle support align with the screw holes on the cabinet and foundation.

- Step 4:** Use a rubber hammer to drive the expansion bolts into the foundation screw holes, and then tighten them clockwise with a torque wrench (M12) (torque: 42 ± 4.2 N·m).

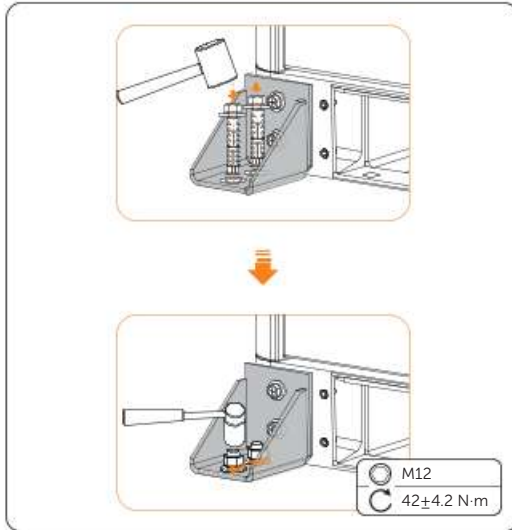

Figure 6-14 Tightening expansion bolts

- Step 5:** After the angle supports have been installed, take out the covers to seal the forklift hole and tighten the screws (M6) (torque: 5 ± 0.5 N·m). Each cover has 4 screws, with a total of 4 covers.

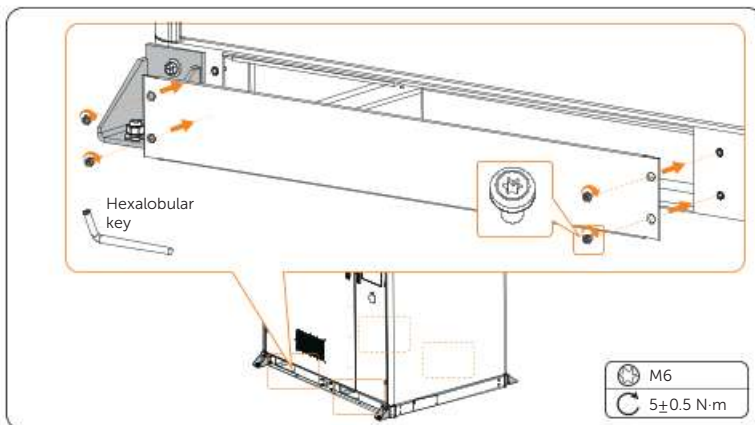

Figure 6-15 Fixed covers

7 Electrical Connection

7.1 Operation before Connection

NOTICE!

- Before wiring, operators are required to learn which parts need to be conducted wiring. For details, please refer to Figure 7-1.

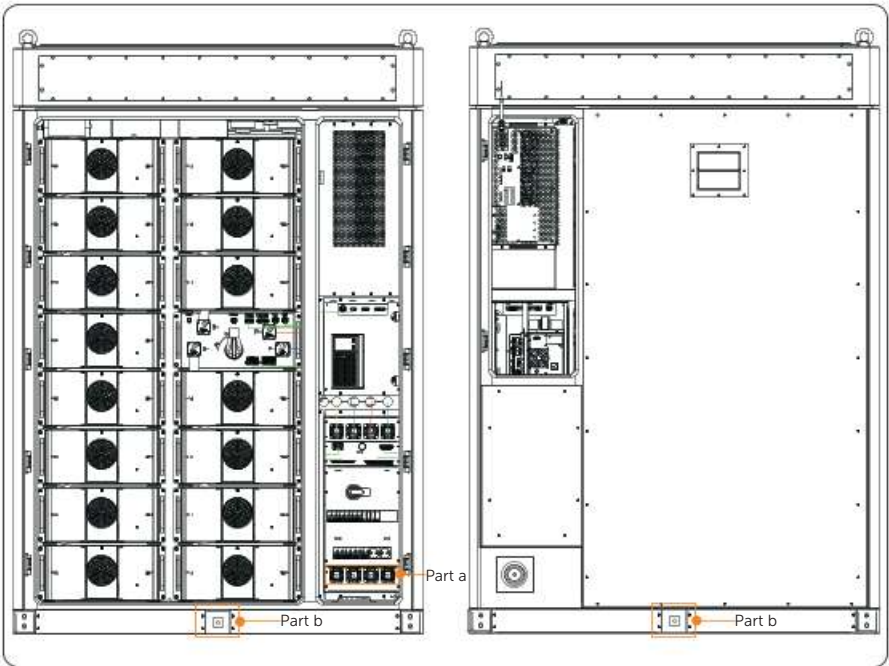

Figure 7-1 Part that needs wiring

Step 1: Please open the door before wiring.

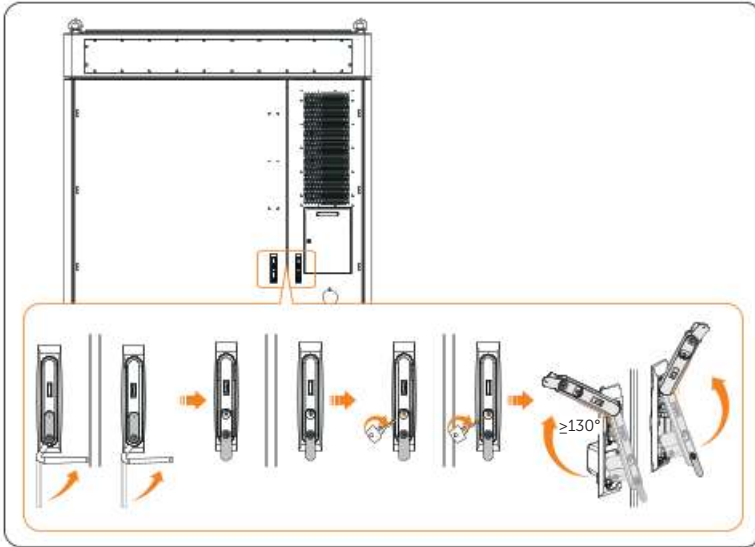

Figure 7-2 Opening the door

NOTICE!

- Please keep the keys properly.

Step 2: Unscrew M4 screws, and remove the cover. There are totalling 4 pieces of M4 screws.

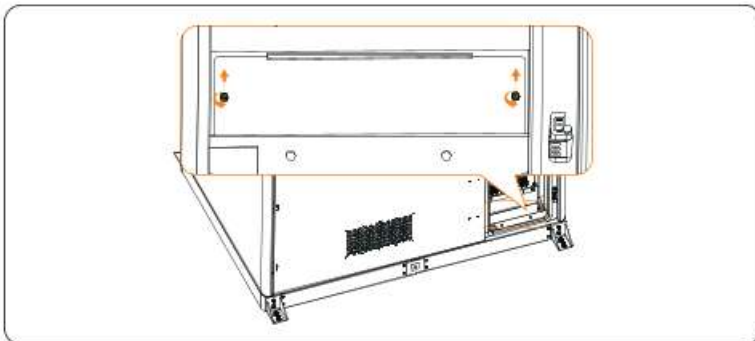

Figure 7-3 Unscrewing M4 screws and removing cover

7.2 Grid Connection

Regarding the grid connection, namely **Part a** in [“Figure 7-1 Part that needs wiring”](#), please strictly follow the steps below.

- Step 1:** Strip the five-core cable about 22 cm to 26 cm.
Strip the cable jacket (for L1/L2/L3/N) about 18 mm to 24 mm,
Strip the PE cable jacket about 14 mm to 20 mm.

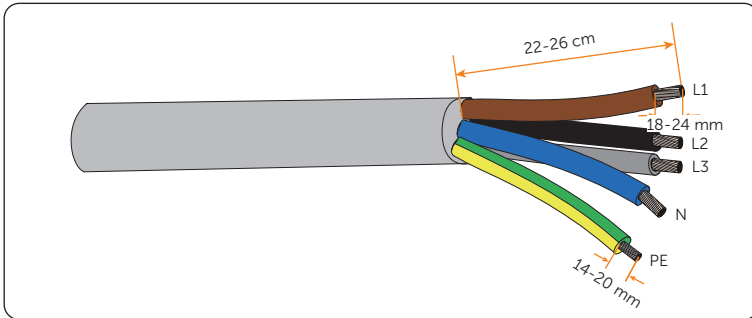

Figure 7-4 Stripping cable jacket

NOTICE!

- It's important to give the power cable a health check before stripping it.
- It's necessary to use controlled motion to strip the insulation down the wire, to prevent damage to the wires.
- Make sure that the insulation layer has been stripped to a sufficient length so that the center conductor is fully exposed without any damage or nicks. In addition, make sure that no extra insulation remains beyond the connector once it's crimped on.

- Step 2:** Cut the heat-shrink tubing (Ø15~20 mm) to about 40 to 50 mm long for L1/L2/L3/N wires;
Cut the heat-shrink tubing (Ø10-14 mm) to about 30 to 40 mm long for PE wire;
Carefully slide it onto the end of the cable, and then carefully slip the wires all the way into the copper terminals.

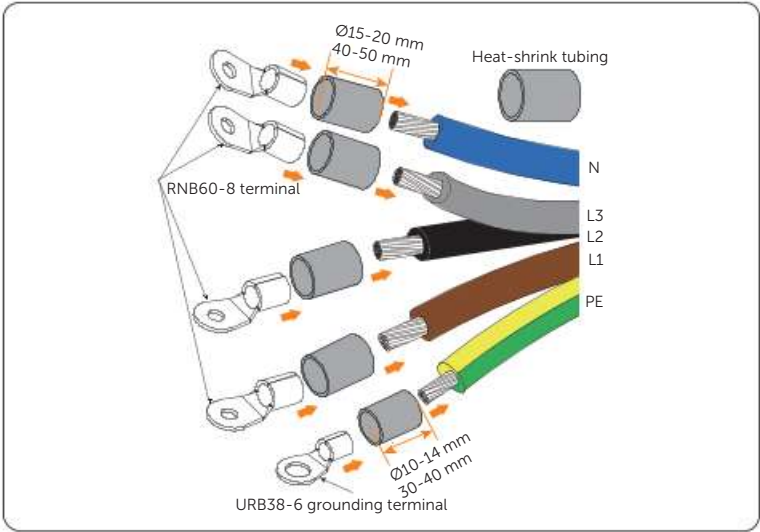

Figure 7-5 Cutting heat-shrink tubing

Step 3: Crimp the terminal using hydraulic wire crimper. Since the procedure for installing a terminal is same, the following steps take the L1 copper wire as an example.

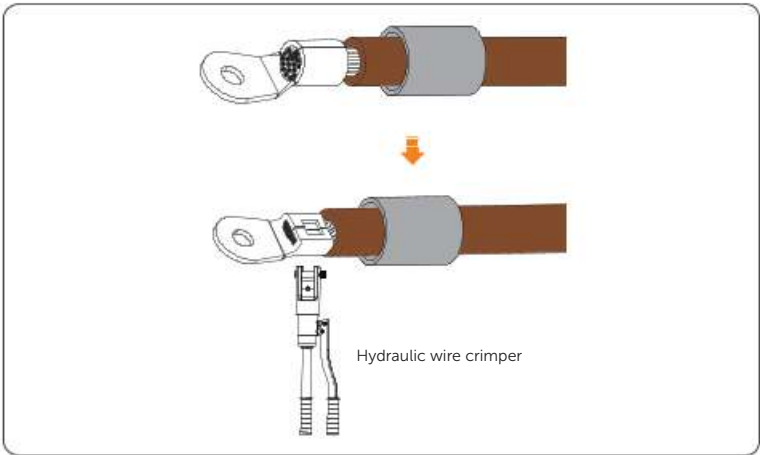

Figure 7-6 Crimping

NOTICE!

- Do not damage the conductor insulation while crimping.
- Do not place the conductor insulation into the terminal.

Step 4: Heat the heat-shrink tubing after it wraps the end of terminal.

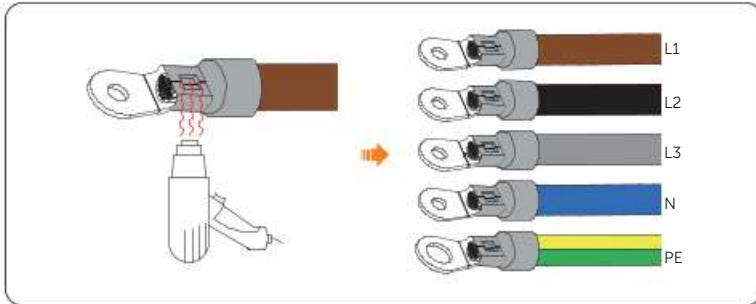

Figure 7-7 Heating

NOTICE!

- Move the heat gun back and forth slowly to distribute the heat evenly across the surface of heat shrink tubing.

Step 5: Run the cable through the cabinet. See Figure 7-8.

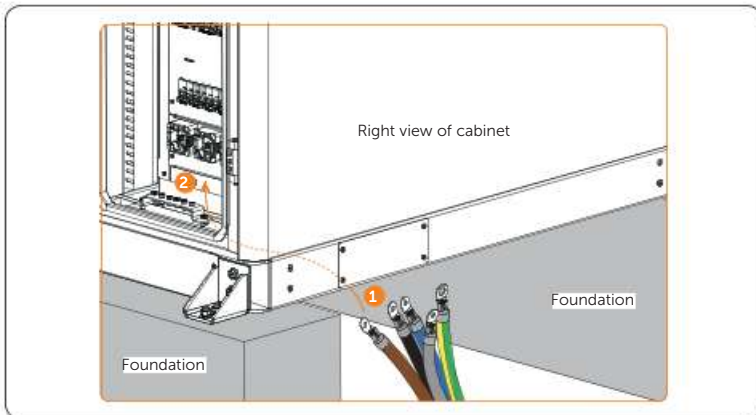

Figure 7-8 Running cable through the cabinet



Figure 7-9 Treading cable out of cable threading hole

NOTICE!

- The mark "*" indicates that the cable threading hole is reserved for parallel.

Step 6: Pull out terminal covers by pressing the buttons on both sides of the cover.

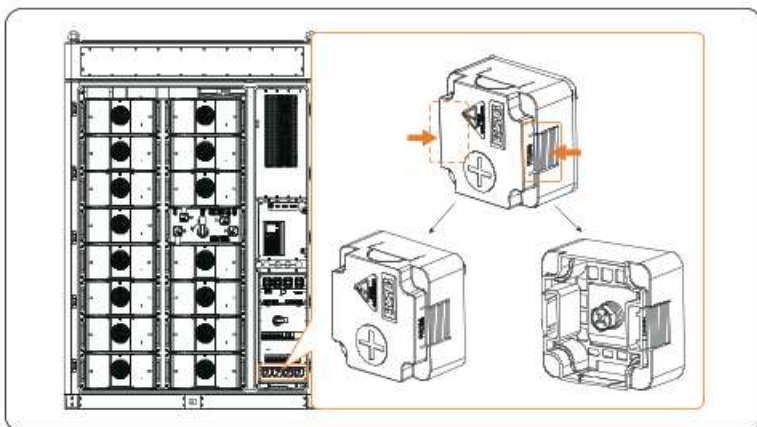

Figure 7-10 Pulling out covers

Step 7: Unscrew the M8 screws using torque wrench, connect the assembled L1/L2/L3/N wires to the wire interface, and then tighten them (torque: 12 ± 1 N·m). There are a total of 4 pieces of M8 screws.

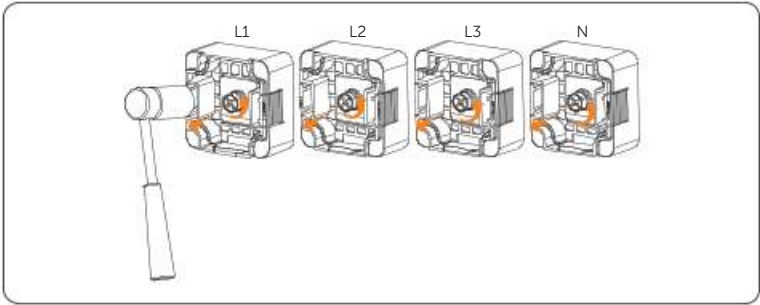

Figure 7-11 Unscrewing M8 screws

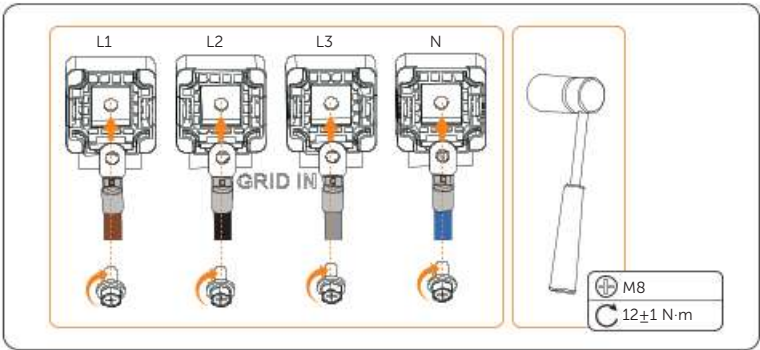

Figure 7-12 Tightening M8 screws

Step 8: Reinstall the terminal covers on L1/L2/L3/N ports.

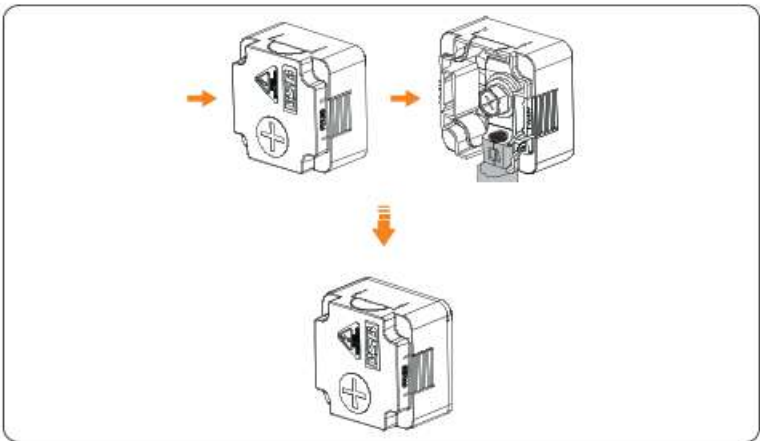

Figure 7-13 Reinstalling terminal cover

Step 9: Unscrew M8 screw using torque wrench, connect the assembled PE wire to the copper bar, and then tighten it (torque: 12 ± 1 N·m).

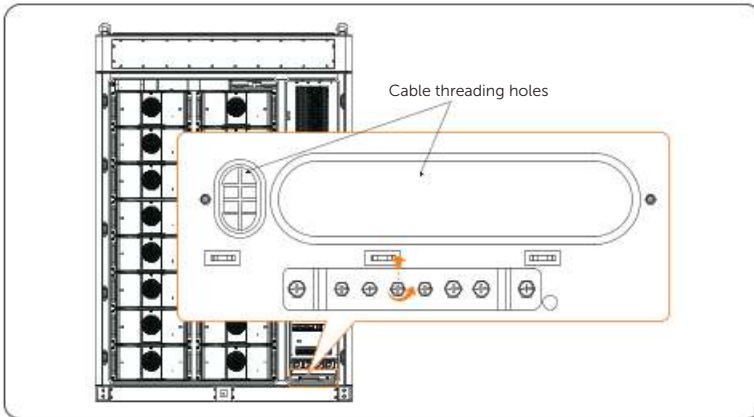

Figure 7-14 Unscrewing M8 screws

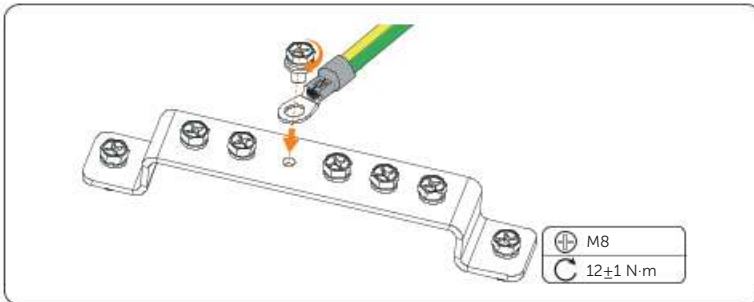

Figure 7-15 Tightening M8 screws

NOTICE!

- There are four common grounding points in the copper bar. Any one of these point can be selected.

Step 10: Lay the fireproof mud to plug of the hole.

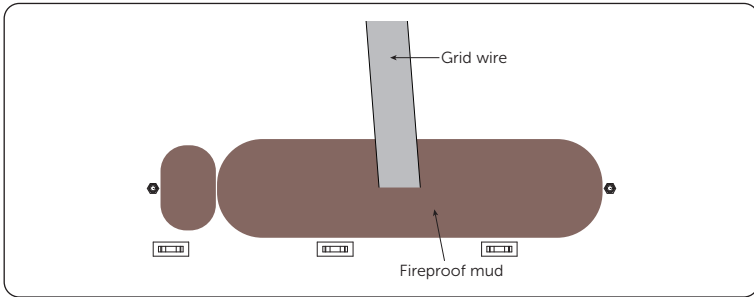

Figure 7-16 Laying fireproof mud

NOTICE!

Notice for fireproofing mud:

- Take out the fireproof mud delivered with the cabinet and knead it into a ball shape. In the case of the low temperature, place it into warm water, of which the temperature range is between 40°C and 70 °C, with its package until it is soft.
- Clean the area around the cable threading hole before sealing it.
- The fireproof mud should be evenly spread, embedded, or filled in the cable threading hole. If such a hole is too large, a fireproofing board can be placed to enhance fire protection before using the mud.
- The fireproof mud needs to be cured after sealing the cable threading hole. Prevent water from entering and colliding during curing.

7.3 Grounding Plate Connection

Regarding the grounding plate connection, namely **Part b** in [“Figure 7-1 Parts that need wiring”](#), either connection area is available, please strictly follow the steps below.

Step 1: Insert and tighten M12 screw to secure grounding plate (torque: 42 ± 2 N·m).

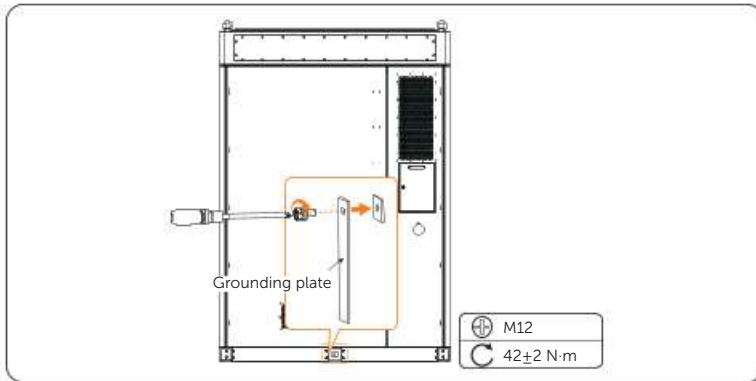

Figure 7-17 Tightening M12 screws

NOTICE!

- The grounding plate is prepared by the user self. Regarding the requirement for the grounding plate, please refer to [“Chapter 4.3 Additionally Required Materials”](#).

8 Commissioning

8.1 Check before Power On

Ensure that all the cables connecting to the EPS and distribution box (grid side) are wired and securely fastened. For details, please refer to the following Table 8-1.

Table 8-1 Checklist

No.	Item	Description
1	Equipment appearance	<ul style="list-style-type: none">• Check the equipment is in good condition, with a clean, non-peeling paint, and rust-free surface.• Ensure that the labels on the equipment are clear and easy to read. If it is damaged, the label shall be replaced at once.
2	Cable appearance	<ul style="list-style-type: none">• Check that the cable jacket is in good condition.• Check that the protective pipes are in good condition.
3	Cable connection	<ul style="list-style-type: none">• Check that the cable connection position is consistent with the design principles.• Ensure that the procedure for crimping terminals strictly observe the requirements, and the terminals are securely fastened.• Check that the lables on the both sides of cables are clear, and the direction of both labels is the same.
4	Wiring	<ul style="list-style-type: none">• Ensure that the wiring procedure is consistent with the principle of separation of strong and weak electricity.• Ensure that the cables are neatly places.• Leave a little extra length for adjustments.• Keep cables tidy in the cabinet.
5	Copper bars in the battery pack	<ul style="list-style-type: none">• Check to make sure the copper bars are not deformed.
6	Button/Switch	<ul style="list-style-type: none">• Check the distribution box's switch is "OFF".• Check the battery packs' switches are "OFF".

8.2 Power ON

Regarding the detailed location of the modules in the cabinet, please refer to ["Figure 2-3 Parts description \(in the opened state\)"](#).

Step 1: Rotate the switch on the distribution box 90° counter-clockwise to "ON".

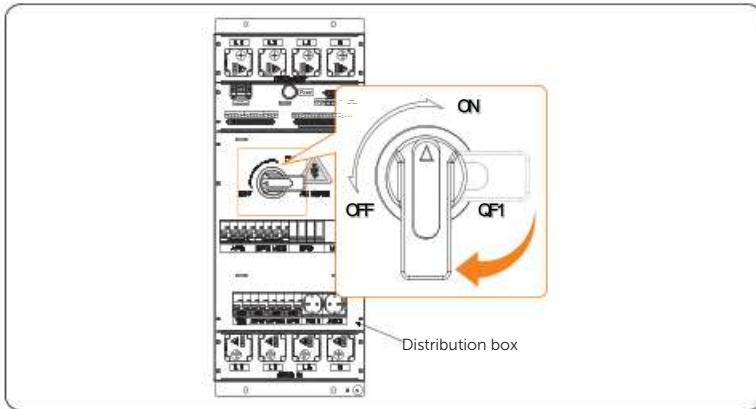

Figure 8-1 Rotating switch

Step 2: Flip up breakers on the distribution box orderly, with correct order of "APS", "SPD MCB", "HVAC MCB", "APS1", "APS2" and "UPS".

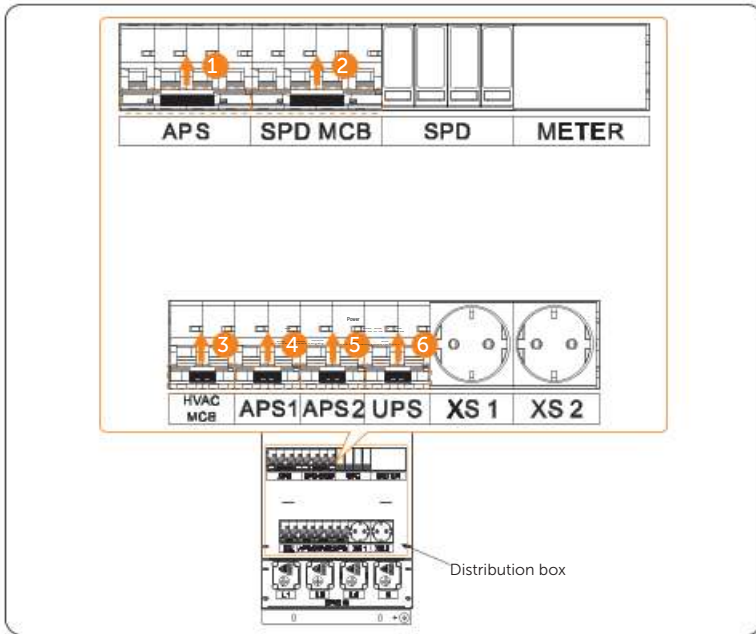

Figure 8-2 Flipping up breakers

Step 3: The startup sound on boot will be heard when holding and pressing the "Power on/off" button to start the UPS.

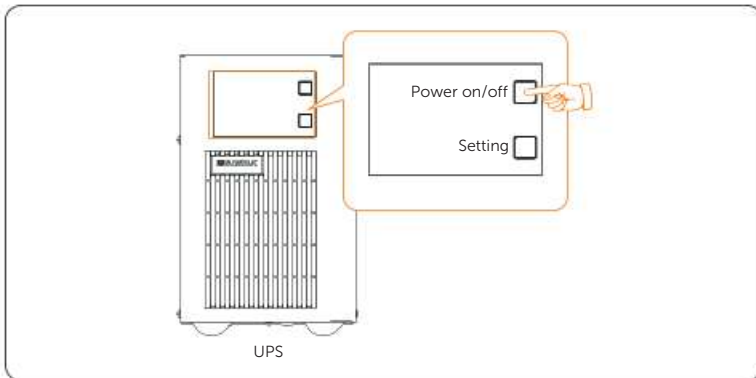

Figure 8-3 Holding and pressing "ON" button

Step 4: Rotate the disconnecter of the high-voltage box to "ON".

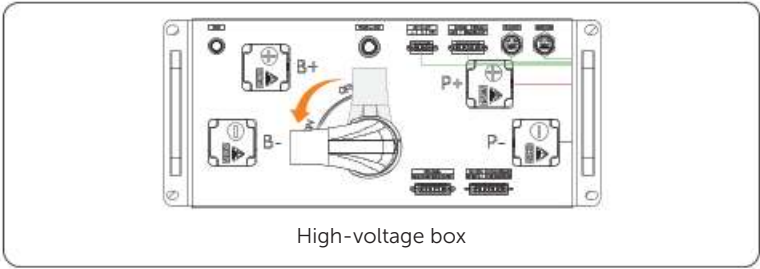

Figure 8-4 Rotating the disconnector

Step 5: Start the inverter.

Step 6: Gently press the power button. At the point, the LED light will come on green.

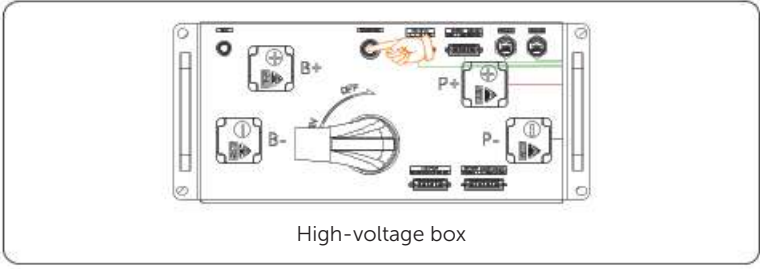

Figure 8-5 Pressing power button gently

Step 7: Close the door after the equipment has been started.

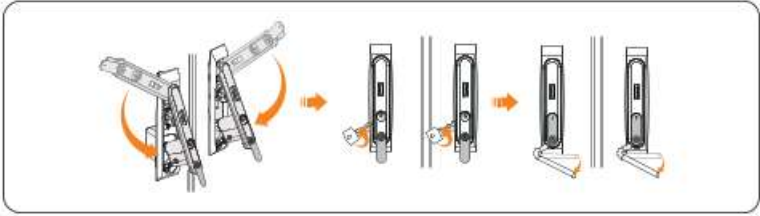

Figure 8-6 Closing the door

NOTICE!

- Please properly keep the key.

9 Troubleshooting and Maintenance

9.1 Power Off

Check whether the system is still running before power off. Do not power off if the device is "under load".

There are two circumstances: 1. Normal power off; 2. Emergency power off.

Regarding the detailed location of the modules in the cabinet, please refer to ["Figure 2-3 Parts description \(in the opened state\)"](#).

Normal Power Off

Step 1: Open the door.

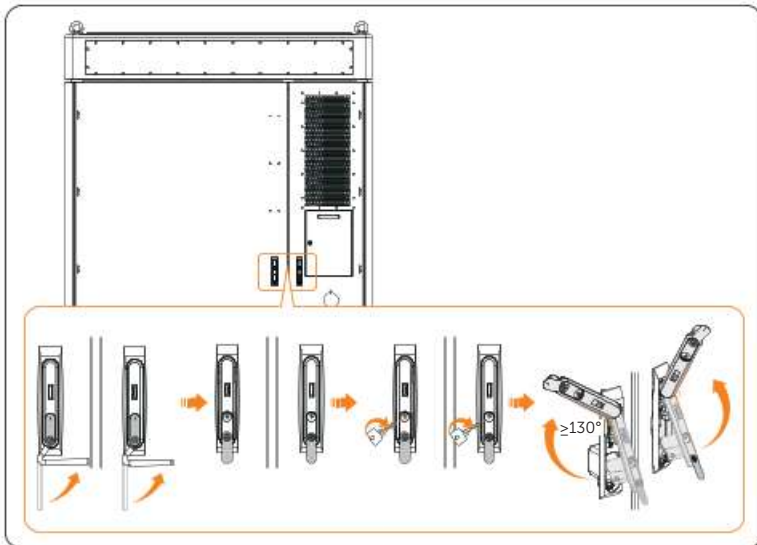

Figure 9-1 Opening the door

Step 2: Gently press the power button, and rotate the disconnecter of the high-voltage box to "OFF".

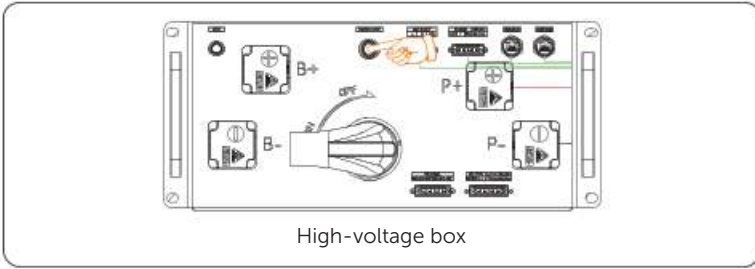

Figure 9-2 Pressing power button

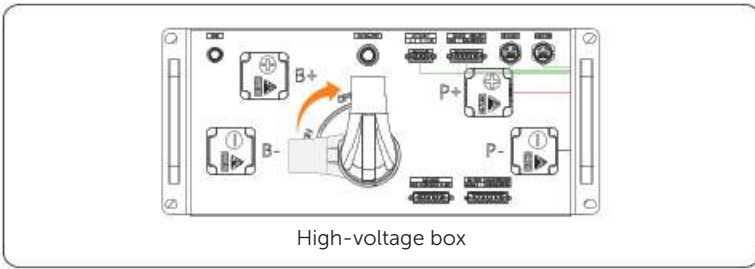

Figure 9-3 Rotating the disconnecter

Step 3: Shut down the inverter.

Step 4: Hold and press the "Power on/off" button to power off the UPS.

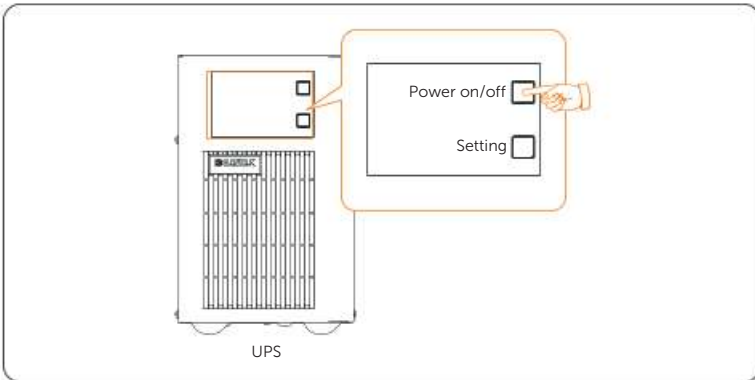

Figure 9-4 Holding and pressing OFF button

Step 5: Flip down breakers on the distribution box orderly, with correct order of "APS", "SPD MCB", "HVAC MCB", "APS1", "APS2" and "UPS".

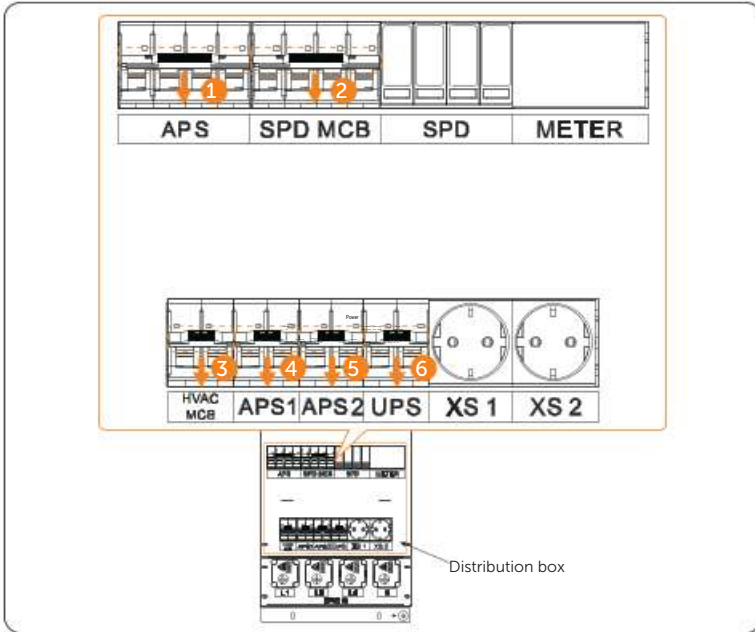

Figure 9-5 Flipping down breakers

Step 6: Rotate the switch on the distribution box 90° clockwise to "OFF".

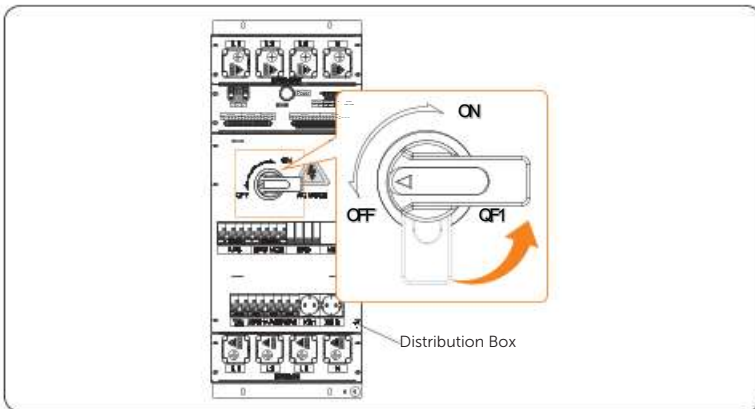

Figure 9-6 Rotating switch

WARNING!

- The device may still have power and heat after turning off, which may cause electric shock and personal injuries. Therefore, please allow it to cool for at least 5 minutes and wear PPE before conducting maintenance.

Emergency Power Off

WARNING!

- Do not press the emergency stop button except for emergencies.

Step 1: Rotate the cover

Step 2: Press the emergency stop button.

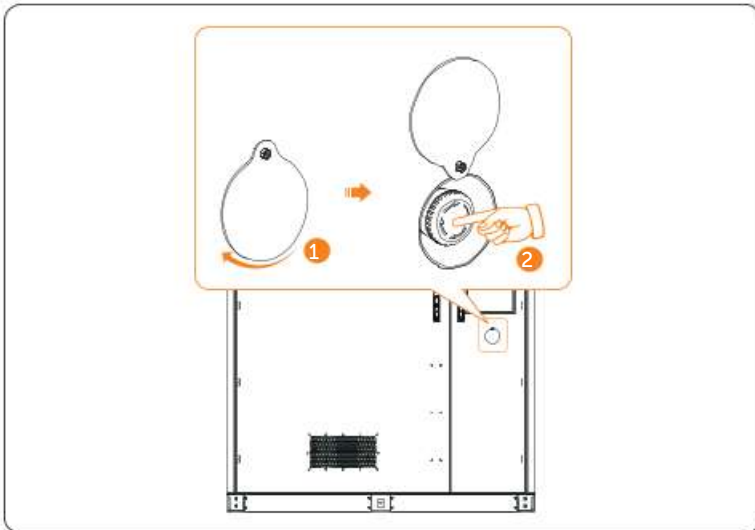

Figure 9-7 Pressing emergency stop button

NOTICE!

If it has been pressed, the emergency stop button must be reset before starting the equipment. The reset steps are shown as follows:

- Rotate the cover;
- Rotate the button according to the arrow direction shown on the button. Then the button will spring back to its original position.

9.2 Troubleshooting

This section lists the possible problems with the equipment, and provides information and procedures for identifying and resolving them. In case of any errors, check for the warnings or error messages on the system control panel or App, and then refer to the suggestions below. For further assistance, contact SolaX Customer Service. Please provide the model and SN of the cabinet, and be prepared to describe the system installation details.

Table 9-1 Troubleshooting list

Facult	Description and Diagnosis
UCellHi_4	<p>Single Cell Overvoltage Category IV</p> <ul style="list-style-type: none"> • Do not power on, and the charging current is limited to 0 A. If the relay does not receive a power-off instruction from the inverter, it will be turned off forcefully after 3 seconds. • Or contact SolaX for help.
UCellHi_5	<p>Single Cell Overvoltage Category V</p> <ul style="list-style-type: none"> • Do not power on, and the charging current is limited to 0 A. If the relay does not receive a power-off instruction from the inverter, it will be turned off forcefully after 1 second. • Or contact SolaX for help.
UCellLow_4	<p>Single Cell Undervoltage Category IV</p> <ul style="list-style-type: none"> • Do not power on, and the charging current is limited to 0 A. If the relay does not receive a power-off instruction from the inverter, it will be turned off forcefully after 3 seconds. • Or contact SolaX for help.
UCellLow_5	<p>Single Cell Undervoltage Category V</p> <ul style="list-style-type: none"> • Do not power on, and the charging current is limited to 0 A. If the relay does not receive a power-off instruction from the inverter, it will be turned off forcefully after 3 seconds. • Or contact SolaX for help.
UCellDiff	<p>Voltage difference fault</p> <ul style="list-style-type: none"> • Or contact SolaX for help.
HVBOver_4	<p>Overvoltage category IV of total voltage</p> <ul style="list-style-type: none"> • The charging current is limited to 0 A. If the relay does not receive a power-off instruction from the inverter, it will be turned off forcefully after 3 seconds. • Or contact SolaX for help.

Fault	Description and Diagnosis
HVBOVer_5	<p>Overvoltage category V of total voltage</p> <ul style="list-style-type: none"> • The charging current is limited to 0 A. If the relay does not receive a power-off instruction from the inverter, it will be turned off forcefully after 1 second. • Or contact SolaX for help.
HVBLow	<p>Undervoltage category IV of total voltage</p> <ul style="list-style-type: none"> • The charging current is limited to 0 A. If the relay does not receive a power-off instruction from the inverter, it will be turned off forcefully after 1 second. • Or contact SolaX for help.
HVBLow	<p>Undervoltage category V of total voltage</p> <ul style="list-style-type: none"> • The charging current is limited to 0 A. If the relay does not receive a power-off instruction from the inverter, it will be turned off forcefully after 1 second. • Or contact SolaX for help.
PosRlyAdh	<p>Sticking contacts of main positive relay</p> <ul style="list-style-type: none"> • The charging current is limited to 0 A. If the relay does not receive a power-off instruction from the inverter, it will be turned off forcefully after 1 second. • Or contact SolaX for help.
PosRlyOpen	<p>Open circuit of main positive relay</p> <ul style="list-style-type: none"> • The charging current is limited to 0 A. If the relay does not receive a power-off instruction from the inverter, it will be turned off forcefully after 1 second. • Or contact SolaX for help.
TempHigh	<p>Overtemperature fault</p> <ul style="list-style-type: none"> • The charging current is limited to 0 A. If the relay does not receive a power-off instruction from the inverter, it will be turned off forcefully after 1 second. • Or contact SolaX for help.
TLineFlt_1	<p>Temperature sampling fault level 1</p> <ul style="list-style-type: none"> • Check if the temperature sensor is short-circuited. • Or contact SolaX for help.
TLineFlt_4	<p>Temperature sampling fault level 4</p> <ul style="list-style-type: none"> • The charging current is limited to 0 A. If the relay does not receive a power-off instruction from the inverter, it will be turned off forcefully after 3 seconds. • Or contact SolaX for help.

Fault	Description and Diagnosis
TempLow	Low-temperature fault <ul style="list-style-type: none">• The charging current is limited to 0 A. If the relay does not receive a power-off instruction from the inverter, it will be turned off forcefully after 1 second.• Or contact SolaX for help.
DsgOver_4	Discharge overcurrent fault level 4 <ul style="list-style-type: none">• The charging current is limited to 0 A. If the relay does not receive a power-off instruction from the inverter, it will be turned off forcefully after 3 seconds.• Or contact SolaX for help.
DsgOver_5	Discharge overcurrent fault level 5 <ul style="list-style-type: none">• The charging current is limited to 0 A. If the relay does not receive a power-off instruction from the inverter, it will be turned off forcefully after 1 second.• Or contact SolaX for help.
ChgOver_4	Charge overcurrent fault level 4 <ul style="list-style-type: none">• The charging current is limited to 0 A. If the relay does not receive a power-off instruction from the inverter, it will be turned off forcefully after 3 seconds.• Or contact SolaX for help.
ChgOver_5	Charge overcurrent fault level 5 <ul style="list-style-type: none">• The charging current is limited to 0 A. If the relay does not receive a power-off instruction from the inverter, it will be turned off forcefully after 1 second.• Or contact SolaX for help.
ICOMFault	Internal communication fault <ul style="list-style-type: none">• Do not power on, and the charging current is limited to 0 A. If the relay does not receive a power-off instruction from the inverter, it will be turned off forcefully after 1 second.• Or contact SolaX for help.
OCOMFault	External communication fault <ul style="list-style-type: none">• Do not power on, and the charging current is limited to 0 A. If the relay does not receive a power-off instruction from the inverter, it will be turned off forcefully after 1 second.• Or contact SolaX for help.
MCOMFault	Intermediate network communication fault <ul style="list-style-type: none">• Do not power on, and the charging current is limited to 0 A.• Or contact SolaX for help.

Facult	Description and Diagnosis
UCellLineOpenFlt	<p>Voltage sampling fault</p> <ul style="list-style-type: none"> • The charging current is limited to 0 A. If the relay does not receive a power-off instruction from the inverter, it will be turned off forcefully after 1 second. • Or contact SolaX for help.
VoltSensorFlt	<p>Voltage sensor fault</p> <ul style="list-style-type: none"> • The charging current is limited to 0 A. If the relay does not receive a power-off instruction from the inverter, it will be turned off forcefully after 1 second. • Or contact SolaX for help.
CurrSensorFlt	<p>Current sensor fault</p> <ul style="list-style-type: none"> • Contact SolaX for help.
NegRlyAdh	<p>Sticking contacts of main negative relay</p> <ul style="list-style-type: none"> • Restart the device. • Or contact SolaX for help.
NegRlyOpen	<p>Open circuit of main negative relay</p> <ul style="list-style-type: none"> • Restart the device. • Or contact SolaX for help.
FlashFlt	<p>Flash fault</p> <ul style="list-style-type: none"> • Check if the external Flash communication is normal. • Or contact SolaX for help.
ChgReqFlt	<p>Charging request fault</p> <ul style="list-style-type: none"> • Check the device is properly charged. • Or contact SolaX for help.
InsFlt	<p>Insulation fault</p> <ul style="list-style-type: none"> • The charging current is limited to 0 A. If the relay does not receive a power-off instruction from the inverter, it will be turned off forcefully after 1 second. • Or contact SolaX for help.
SOCLowFlt	<p>Low SOC</p> <ul style="list-style-type: none"> • Check if the device is running out of power. • Or contact SolaX for help.
PreChgFailFlt	<p>External short-circuit fault</p> <ul style="list-style-type: none"> • The charging current is limited to 0 A. If the relay does not receive a power-off instruction from the inverter, it will be turned off forcefully after 1 second. • Or contact SolaX for help.

Fault	Description and Diagnosis
AFEProtectFlt	Battery's hardware protection fault <ul style="list-style-type: none">• The charging current is limited to 0 A. If the relay does not receive a power-off instruction from the inverter, it will be turned off forcefully after 1 second.• Or contact SolaX for help.
SelfCheckFlt	Self-test fault <ul style="list-style-type: none">• The charging current is limited to 0 A. If the relay does not receive a power-off instruction from the inverter, it will be turned off forcefully after 1 second.• Or contact SolaX for help.
LinkerTempHiFlt_3	Fault on overtemperature of high-voltage connector <ul style="list-style-type: none">• Check whether the charge/discharge current is over 50% of rated charge/discharge current.• Or contact SolaX for help.
LinkerTempHiFlt_5	Fault on overtemperature of high-voltage connector <ul style="list-style-type: none">• Check whether the charge/discharge current is over 50% of rated charge/discharge current.• Or contact SolaX for help.
BatLinkerTempHi_5	High-temperature fault of pole <ul style="list-style-type: none">• The charging current is limited to 0 A. If the relay does not receive a power-off instruction from the inverter, it will be turned off forcefully after 3 seconds.• Or contact SolaX for help.
FanFault	Fan fault <ul style="list-style-type: none">• Check whether any foreign objects stick to the fan.• Contact SolaX for help.
FuseSt	Fuse fault <ul style="list-style-type: none">• Contact SolaX for help.
DCSwitch	DC switch fault <ul style="list-style-type: none">• Contact SolaX for help.

9.3 Maintenance

Regular maintenance is required for the device. The table below lists the operational maintenance for expressing the optimum device performance. More frequent maintenance service is needed in the worse work environment. Please make records of the maintenance.



WARNING!

- Only qualified person can perform the maintenance for the device.
- Only use the spare parts and accessories approved by SolaX for maintenance.

9.3.1 Maintenance Routine

Table 9-1 Maintenance list

Check Item	Description	Interval Time
The operating status and environment of the system	<ul style="list-style-type: none"> • Check whether there is any damage to the distributed energy system, and the equipment is deformed. • Check whether there are any abnormal noise in the running system. • Check whether the parameter is correct shown in the screen. • Check whether there is any damage to the main components. • Check whether the temperature of the equipment shell is normal. Meanwhile, it is suggested to use a thermal imager or any other monitoring systems to identify signs of heat. • Check whether the surrounding is at normal humidity level, and there is any damage to the dust and air filters. <ol style="list-style-type: none"> a. Must ensure that the air intake is well ventilated. Otherwise, the battery pack failure will be caused due to overheating. b. Please gently open the door to prevent raising dust from the filter cotton. Otherwise, the smoke detector will alarm and give a command to the automatic fire sprinkler to spray gas. 	Every 6 months
System cleaning	<ul style="list-style-type: none"> • Check whether the circuit boards and components are clean. • If necessary, clean the modules by air compressor. <p>Note: The system must be shut down before cleaning.</p>	Every 6 months

Check Item	Description	Interval Time
Electrical connection	<ul style="list-style-type: none"> • Check whether the power cables are fastened securely. If not, please tighten them again according to the torque written in the document. • Check there is any damage to the cables, especially the cable jacket connecting with the metal parts. • Check whether the electrical insulation tape is in good condition and no peeling. 	Every 6 months
Terminal and block connection	<ul style="list-style-type: none"> • Check whether the screws are fastened securely. If not, please tighten them again according to the torque written in the document. • Check whether there is any fading to the screws and copper bars. • Check whether the wiring arrangement is reasonable. • Check whether the loop terminals are in good condition, and the temperature of the screws is normal. 	Every 6 months
Relay maintenance	<ul style="list-style-type: none"> • Do a routine inspection for the corrosion of all metal components. • Do an annual inspection for the connectors (auxiliary switches and microswitches) to make sure that the equipment is in good running condition. • Check whether the parameter is correct (especially the voltage and insulation). 	Every 6 months
Aerosol inspection	<ul style="list-style-type: none"> • Check whether the aerosol is in good condition, and wiring are fastened securely. 	Every 6 months
Safety function	<ul style="list-style-type: none"> • Check whether the emergency stop button and LED is in good working condition. • Check the stopping signal and communication by simulating the shutdown operation. • Check whether there are any damages to warning signs and other labels pasted on the equipment. If so, please replace them in time. 	Every 6 months

9.3.2 Disassembly and Clean of Air Conditioner Filter



WARNING!

- The air conditioner must be powered off before disassembly and clean of air conditioner.
- The device may still have power and heat after turning off, which may cause electric shock and personal injuries. Therefore, please allow it to cool for at least 5 minutes and wear PPE before conducting maintenance.

Step 1: Unscrew M5 screws, and orderly dismantle aluminum mesh plate, stainless steel gauze, and black filter.

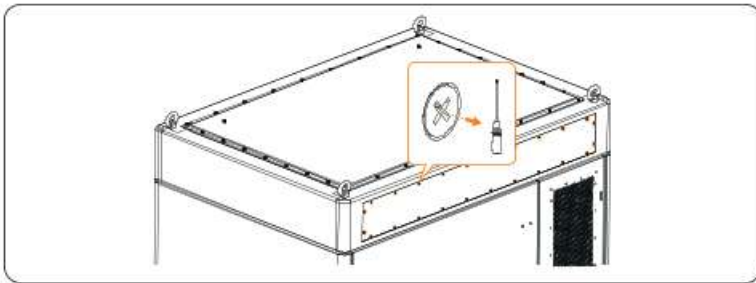

Figure 9-8 Unscrewing M5 screws

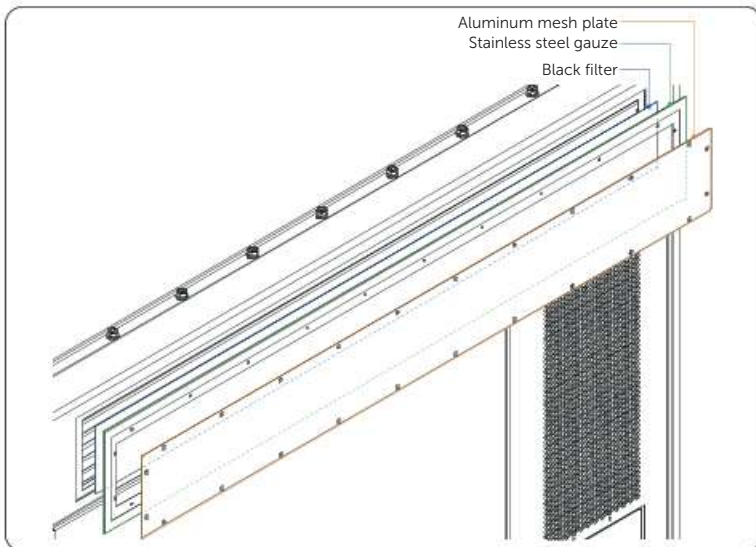

Figure 9-9 Dismantling aluminum mesh plate, stainless steel gauze, black filter

Step 2: Clean aluminum mesh plate and stainless steel gauze, and replace the black filter.

Step 3: Orderly reinstall the black filter, stainless steel gauze, and aluminum mesh plate.

Step 4: Insert and tighten M5 screws (x 24) (torque: 0.6-0.8 N·m).

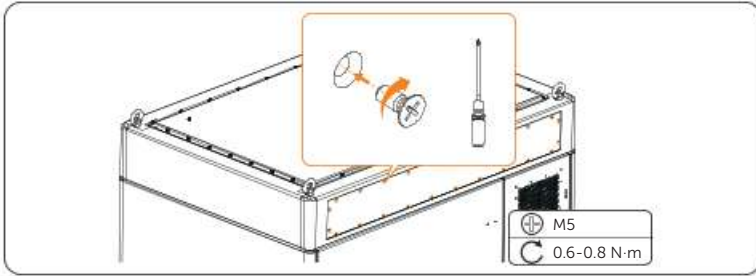

Figure 9-10 Tightening M5 screws

Step 5:

9.3.3 Maintenance of Battery Pack

Circumstance	Measure
If the ambient temperature for storage is between 30°C and 50°C	Recharge the battery packs at least once every 6 months
If the ambient temperature for storage is between -20°C and 30°C	Recharge the battery packs at least once every 12 months.
In the first installation	The interval among manufacture dates of battery packs shall not be exceed 3 months.
If a battery pack is replaced or added for capacity expansion	Each battery's SOC should be consistent. The max. SOC difference should be $\pm 5\%$.
If users want to increase their battery system capacity	Ensure that the SOC of the existing system capacity is about 40%. The manufacture date of the new battery pack shall not exceed 6 months. If the manufacture date of the new one exceeds 6 months, please charge it to around 40%.

WARNING!

- Only qualified person can perform the maintenance for the device.

10 Dispose of Wasted and Damaged Battery Pack

Please dispose of the rechargeable battery or accessories in accordance with the disposal regulations for electronic waste which is applied at the installation site.

NOTICE!

- The expenses for dispose of the wasted or damaged battery packs incurred shall be borne by the user.

11 Technical Data

Cabinet (AC Side)

Model	TRENE-P100B215I
Rated AC power [kW]	100
Rated AC current [A]	144.4
Max. AC apparent power [kVA]	110
Nominal grid voltage [V]	400 (-20% ~ +15%)
Nominal grid frequency [Hz]	50 / 60
Adjustable power factor range	0.99 leading ~ 0.99 lagging
THDi (Rated power) [%]	< 3
Max. efficiency [%]	98%
DC side anticipated short circuit current [A]	8500
AC side anticipated short circuit current [kA]	8

Battery

Model	TRENE-P100B215I
Battery type	LiFePO4
Battery capacity [kWh]	215
Rated battery voltage [V]	768
Battery voltage range [V]	600 ~ 876
Discharge depth [%]	90
Rated charge/discharge current [A]	140

General Parameter

Model	TRENE-P100B215I
Dimension (W×H×D) [mm]	1680 × 2420 × 1200
Weight [kg]	2800
Operating temperature range [°C]	-30 ~ 50
Relative humidity (Non-condensing) [%]	0 ~ 95
Altitude [m]	3000
Cooling concept	Smart air cooling
Ingress protection	IP55
Fire protection	Aerosol (Optional: Novec1230) / Water
Topology	Non-isolated
Certificates	IEC62619, IEC63056:2000, IEC61000, IEC62477-1, UN38.3, GB/T36276, GB/T34131

12 Appendix

12.1 How to Repaint the Cabinet

In bad weather conditions, such as rain, snow, gales, sandstorms, etc., stop carrying out repainting even if the equipment is installed outside.

Strictly comply with the pantone color described in the document while repainting.

Repainting description

To keep the equipment appearance intact, please repaint it immediately in the case of flaking and peeling paint.

NOTICE!

- Prepare tools and sufficient materials according to the On-site Assessment Report of the Extent of the Paint Damage.

Table 12-1 Repainting description

Extent of the paint damage	Tools and materials	Procedure	Description
Light scratches on equipment (without reaching the steel substrate)	Spray paint or oil paint, hairbrush (for small scratched area), fine sandpaper, absolute alcohol, cotton cloth, paint sprayer (for large scratched area).	Steps 1, 2, 4, and 5	<ol style="list-style-type: none"> Regarding the painting, the pantone color (Pantone 11-4800TCX) is for reference. Regarding the light scratches or small area of stubborn stains, it is suggested to use spray paint and hairbrush.
Stubborn stains on equipment	Spray paint or oil paint, zinc-rich primer, hairbrush (for small scratched area), fine sandpaper, absolute alcohol, cotton cloth, paint sprayer (for large scratched area).	Steps 1, 2, 3, 4, and 5	
Deep scratches on equipment (the damaged primer, reaching the steel substrate)	<p>If the logo or any other patterns are damaged, contact your local spraying company to customize a repainting plan in accordance with the size, color, and extent of the damage to the logo or patterns.</p> <ol style="list-style-type: none"> If the damaged area is < 100 mm² and the depth is < 3 mm, it is recommended to use a poly-putty base to fix the dents and dings first and then deal with them according to the Procedure for Deep Scratches. If the damaged area is > 100 mm² or the depth is > 3 mm, contact your local supplier to make a repair plan based on the actual situation. 		<ol style="list-style-type: none"> Regarding the deep scratches or the large area of stubborn stains, it is suggested to use oil paint and paint sprayer. Make sure that the damaged area with even coverage and thin, to create a consistent and even appearance. Allow the paint to dry for at least 30 minutes before conducting the next step.
The damaged logo or pattern, dents and dings			

Procedure

Step 1: Gently sand the scratched surface with a fine sandpaper to remove rust or stains.

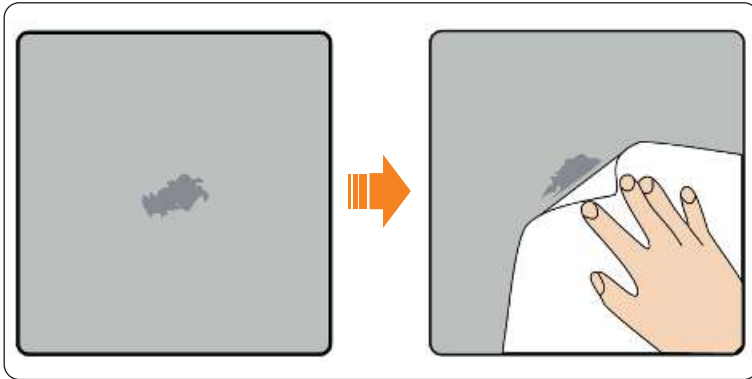

Figure 2-11 Sanding the scratched surface

Step 2: Clean the scratched area properly with a wet cotton cloth to remove dirt, and then wipe it with a dry cotton cloth.

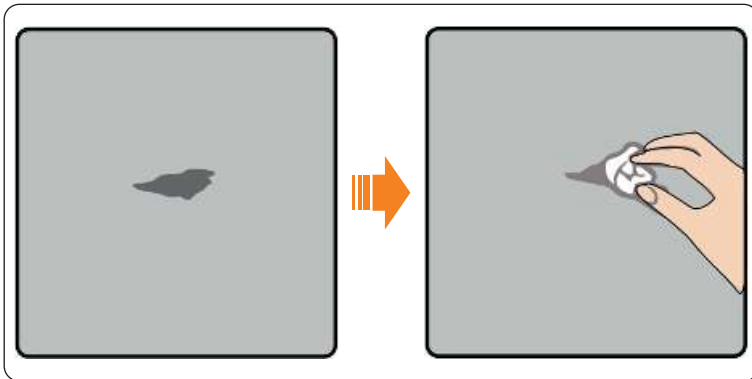

Figure 2-12 Cleaning the scratched area

Step 3: Apply the zinc-rich primer to the scratched area through a hairbrush or paint sprayer.

NOTICE!

- If the bare metal underneath can be seen,
 - » Firstly, the epoxy zinc-rich primer must be applied;
 - » Secondly, apply the acrylic top coat until the primer is dry and the bare metal cannot be seen.
- The epoxy zinc-rich primer and the acrylic top coat shall be decided according to the surface coating of the equipment.

Step 4: Given the damage degree, one of the following methods, self painting, brush painting, or paint sprayer can be chosen to evenly paint the damaged area.

NOTICE!

- Make sure that the damaged area with even coverage, smooth and thin, to create a consistent and even appearance.
- If there are any other colors on the equipment, carefully position the tape or paper over the undamaged area before painting, to avoid staining these colors.

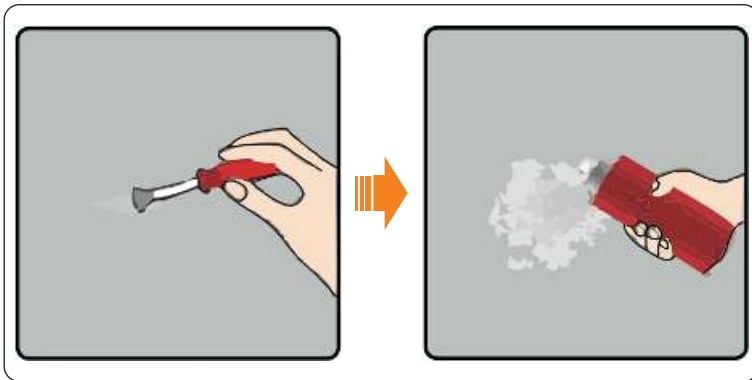

Figure 2-13 Painting the damaged area

Step 5: Allow the paint to dry for at least 30 minutes, and then check whether the repaired area meets requirements.

NOTICE!

- The color of the repaired area shall be consistent with the surrounding area. Use a colorimeter to measure the color difference, of which Delta E shall be ≤ 3 . If the color cannot be measured by a colorimeter, please confirm that there is no obvious color difference at the edges between the repaired area and the surrounding area, as well as no bumps, scratches, flakings, or breaks.
- In the case of spray painting, it is suggested to paint 3 times first before checking whether it meets the requirements. If not, please repeat spray painting until it meets the requirements.

Contact Information



UNITED KINGDOM

- 📍 Unit C-D Riversdale House, Riversdale Road, Atherstone, CV9 1FA
- ☎ +44 (0) 2476 586 998
- ✉ service.uk@solaxpower.com



TURKEY

- 📍 Fevzi Çakmak mah. aslım cd. no 88 A Karatay / Konya / Türkiye
- ✉ service.tr@solaxpower.com



USA

- 📍 3780 Kilroy Airport Way, Suite 200, Long Beach, CA, US 90806
- ☎ +1 (408) 690 9464
- ✉ info@solaxpower.com



POLAND

- 📍 WARSAW AL. JANA P. II 27. POST
- ☎ +48 662 430 292
- ✉ service.pl@solaxpower.com



ITALY

- ☎ +39 011 19800998
- ✉ support@solaxpower.it



PAKISTAN

- ✉ service.pk@solaxpower.com



AUSTRALIA

- 📍 21 Nicholas Dr, Dandenong South VIC 3175
- ☎ +61 1300 476 529
- ✉ service@solaxpower.com



GERMANY

- 📍 Am Tullnaupark 8, 90402 Nürnberg, Germany
- ☎ +49 (0) 6142 4091 664
- ✉ service.eu@solaxpower.com
- ✉ service.dach@solaxpower.com



NETHERLANDS

- 📍 Twekkeler-Es 15 7547 ST Enschede
- ☎ +31 (0) 8527 37932
- ✉ service.eu@solaxpower.com
- ✉ service.bnl@solaxpower.com



SPAIN

- ☎ +34 9373 79607
- ✉ tecnico@solaxpower.com



BRAZIL

- ☎ +55 (34) 9667 0319
- ✉ info@solaxpower.com



SOUTH AFRICA

- ✉ service.za@solaxpower.com



SolaX Power Network Technology (Zhejiang) Co., Ltd.

ADD.: No. 278, Shizhu Road, Chengnan Sub-district, Tonglu County,
Hangzhou, Zhejiang, China

E-mail: info@solaxpower.com

www.solaxpower.com